

- LEGEND**
- ON-SITE SUBAREA BOUNDARY
 - OFF-SITE SUBAREA BOUNDARY
 - - - SURFACE FLOW PATH
 - $\frac{S}{L}$ SURFACE FLOW PATH SLOPE
 - $\frac{S}{L}$ SURFACE FLOW PATH LENGTH
 - PROP. "X" SD
 $\frac{S}{L}$ PROPOSED STORM DRAIN PIPE SIZE
 - $\frac{S}{L}$ PIPE FLOW PATH SLOPE
 - $\frac{S}{L}$ PIPE FLOW PATH LENGTH
 - XX ON-SITE SUBAREA LABEL
 - XX OFF-SITE SUBAREA LABEL
 - (XX) ON-SITE ELEVATION NODES
 - (XX) OFF-SITE ELEVATION NODES
 - $Q_p = \frac{XXX}{CFS}$ 10-YEAR PEAK FLOW RATE
 - $T_c = \frac{X.XX}{MIN}$ 10-YEAR TIME OF CONCENTRATION
 - $Q_{100} = \frac{XXX}{CFS}$ 100-YEAR PEAK FLOW RATE
 - $T_{c100} = \frac{X.XX}{MIN}$ 100-YEAR TIME OF CONCENTRATION

IRON LOFTS
IRON LOFTS, LLC

POST-DEVELOPMENT HYDROLOGY MAP
RIVERSIDE, CALIFORNIA

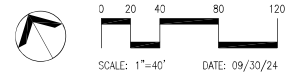

KHR ASSOCIATES
CONSULTING ENGINEERS/SURVEYORS/PLANNERS
17530 Von Karman Ave., Suite 200
Irvine, California 92614
Tel (949) 756-6440

Appendix 2.1

Post-Development Hydrology Calculations: On-Site plus Off-Site Runoff

RATIONAL METHOD HYDROLOGY COMPUTER PROGRAM BASED ON
RIVERSIDE COUNTY FLOOD CONTROL & WATER CONSERVATION DISTRICT
(RCFC&WCD) 1978 HYDROLOGY MANUAL
(c) Copyright 1982-2016 Advanced Engineering Software (aes)
(Rational Tabling Version 23.0)
Release Date: 07/01/2016 License ID 1681

Analysis prepared by:

KHR Associates
17530 Von Karman Avenue
Irvine, CA 92626

***** DESCRIPTION OF STUDY *****

- * IRON LOFTS *
- * POST-DEVELOPMENT HYDROLOGY - ON-SITE PLUS OFF-SITE RUNOFF *
- * 10-YEAR STORM EVENT *

FILE NAME: RIL1-R10.DAT
TIME/DATE OF STUDY: 09:51 08/05/2024

USER SPECIFIED HYDROLOGY AND HYDRAULIC MODEL INFORMATION:

USER SPECIFIED STORM EVENT(YEAR) = 10.00
SPECIFIED MINIMUM PIPE SIZE(INCH) = 4.00
SPECIFIED PERCENT OF GRADIENTS(DECIMAL) TO USE FOR FRICTION SLOPE = 0.95
10-YEAR STORM 10-MINUTE INTENSITY(INCH/HOUR) = 2.140
10-YEAR STORM 60-MINUTE INTENSITY(INCH/HOUR) = 0.800
100-YEAR STORM 10-MINUTE INTENSITY(INCH/HOUR) = 3.210
100-YEAR STORM 60-MINUTE INTENSITY(INCH/HOUR) = 1.200
SLOPE OF 10-YEAR INTENSITY-DURATION CURVE = 0.5491525
SLOPE OF 100-YEAR INTENSITY-DURATION CURVE = 0.5491524

COMPUTED RAINFALL INTENSITY DATA:

STORM EVENT = 10.00 1-HOUR INTENSITY(INCH/HOUR) = 0.808
SLOPE OF INTENSITY DURATION CURVE = 0.5492

RCFC&WCD HYDROLOGY MANUAL "C"-VALUES USED FOR RATIONAL METHOD
NOTE: CONSIDER ALL CONFLUENCE STREAM COMBINATIONS

FOR ALL DOWNSTREAM ANALYSES

USER-DEFINED STREET-SECTIONS FOR COUPLED PIPEFLOW AND STREETFLOW MODEL

NO.	HALF-WIDTH (FT)	CROWN TO CROSSFALL (FT)	STREET-CROSSFALL IN-SIDE / OUT-SIDE/PARK-WAY	CURB HEIGHT (FT)	GUTTER WIDTH (FT)	GEOMETRIES LIP (FT)	MANNING HIKE (FT)	FACTOR (n)
1	30.0	20.0	0.018/0.018/0.020	0.67	2.00	0.0313	0.167	0.0150

GLOBAL STREET FLOW-DEPTH CONSTRAINTS:

1. Relative Flow-Depth = 0.00 FEET
as (Maximum Allowable Street Flow Depth) - (Top-of-Curb)
 2. (Depth)*(Velocity) Constraint = 6.0 (FT*FT/S)
- *SIZE PIPE WITH A FLOW CAPACITY GREATER THAN
OR EQUAL TO THE UPSTREAM TRIBUTARY PIPE.*

FLOW PROCESS FROM NODE 1.00 TO NODE 2.00 IS CODE = 21

>>>>RATIONAL METHOD INITIAL SUBAREA ANALYSIS<<<<<

=====

ASSUMED INITIAL SUBAREA UNIFORM
DEVELOPMENT IS APARTMENT

TC = $K * [(LENGTH^{**3}) / (ELEVATION CHANGE)]^{** .2}$
 INITIAL SUBAREA FLOW-LENGTH(FEET) = 124.00
 UPSTREAM ELEVATION(FEET) = 879.50
 DOWNSTREAM ELEVATION(FEET) = 877.89
 ELEVATION DIFFERENCE(FEET) = 1.61
 TC = $0.323 * [(124.00^{**3}) / (1.61)]^{** .2} = 5.290$
 10 YEAR RAINFALL INTENSITY(INCH/HOUR) = 3.066
 APARTMENT DEVELOPMENT RUNOFF COEFFICIENT = .8706
 SOIL CLASSIFICATION IS "C"
 SUBAREA RUNOFF(CFS) = 0.99
 TOTAL AREA(ACRES) = 0.37 TOTAL RUNOFF(CFS) = 0.99

FLOW PROCESS FROM NODE 2.00 TO NODE 2.00 IS CODE = 10

>>>>MAIN-STREAM MEMORY COPIED ONTO MEMORY BANK # 1 <<<<<

FLOW PROCESS FROM NODE 2.00 TO NODE 2.00 IS CODE = 13

>>>>CLEAR THE MAIN-STREAM MEMORY<<<<<

FLOW PROCESS FROM NODE 3.00 TO NODE 4.00 IS CODE = 21

>>>>RATIONAL METHOD INITIAL SUBAREA ANALYSIS<<<<<

=====

ASSUMED INITIAL SUBAREA UNIFORM
DEVELOPMENT IS APARTMENT

TC = $K * [(LENGTH^{**3}) / (ELEVATION CHANGE)]^{** .2}$
 INITIAL SUBAREA FLOW-LENGTH(FEET) = 93.44
 UPSTREAM ELEVATION(FEET) = 15.00
 DOWNSTREAM ELEVATION(FEET) = 13.00
 ELEVATION DIFFERENCE(FEET) = 2.00
 TC = $0.323 * [(93.44^{**3}) / (2.00)]^{** .2} = 4.275$

COMPUTED TIME OF CONCENTRATION INCREASED TO 5 MIN.

10 YEAR RAINFALL INTENSITY(INCH/HOUR) = 3.163

APARTMENT DEVELOPMENT RUNOFF COEFFICIENT = .8713

SOIL CLASSIFICATION IS "C"

SUBAREA RUNOFF(CFS) = 0.67

TOTAL AREA(ACRES) = 0.24 TOTAL RUNOFF(CFS) = 0.67

FLOW PROCESS FROM NODE 4.00 TO NODE 4.10 IS CODE = 41

>>>>COMPUTE PIPE-FLOW TRAVEL TIME THRU SUBAREA<<<<<

>>>>USING USER-SPECIFIED PIPESIZE (EXISTING ELEMENT)<<<<<

REPRESENTATIVE SLOPE = 0.0100

FLOW LENGTH(FEET) = 59.80 MANNING'S N = 0.009

DEPTH OF FLOW IN 6.0 INCH PIPE IS 4.2 INCHES

PIPE-FLOW VELOCITY(FEET/SEC.) = 4.51

GIVEN PIPE DIAMETER(INCH) = 6.00 NUMBER OF PIPES = 1

PIPE-FLOW(CFS) = 0.67

PIPE TRAVEL TIME(MIN.) = 0.22 Tc(MIN.) = 5.22

LONGEST FLOWPATH FROM NODE 3.00 TO NODE 4.10 = 153.24 FEET.

FLOW PROCESS FROM NODE 4.10 TO NODE 5.00 IS CODE = 41

>>>>COMPUTE PIPE-FLOW TRAVEL TIME THRU SUBAREA<<<<<

>>>>USING USER-SPECIFIED PIPESIZE (EXISTING ELEMENT)<<<<<

REPRESENTATIVE SLOPE = 0.0100

FLOW LENGTH(FEET) = 13.79 MANNING'S N = 0.009

DEPTH OF FLOW IN 8.0 INCH PIPE IS 3.5 INCHES

PIPE-FLOW VELOCITY(FEET/SEC.) = 4.59

GIVEN PIPE DIAMETER(INCH) = 8.00 NUMBER OF PIPES = 1

PIPE-FLOW(CFS) = 0.67

PIPE TRAVEL TIME(MIN.) = 0.05 Tc(MIN.) = 5.27

LONGEST FLOWPATH FROM NODE 3.00 TO NODE 5.00 = 167.03 FEET.

FLOW PROCESS FROM NODE 5.00 TO NODE 5.00 IS CODE = 10

>>>>MAIN-STREAM MEMORY COPIED ONTO MEMORY BANK # 2 <<<<<

FLOW PROCESS FROM NODE 5.00 TO NODE 5.00 IS CODE = 13

>>>>CLEAR THE MAIN-STREAM MEMORY<<<<<

FLOW PROCESS FROM NODE 6.00 TO NODE 7.00 IS CODE = 21

>>>>RATIONAL METHOD INITIAL SUBAREA ANALYSIS<<<<<

=====

ASSUMED INITIAL SUBAREA UNIFORM
DEVELOPMENT IS APARTMENT

TC = $K * [(LENGTH^{**3}) / (ELEVATION CHANGE)]^{**0.2}$
INITIAL SUBAREA FLOW-LENGTH(FEET) = 94.00
UPSTREAM ELEVATION(FEET) = 15.00
DOWNSTREAM ELEVATION(FEET) = 13.00
ELEVATION DIFFERENCE(FEET) = 2.00
TC = $0.323 * [(94.00^{**3}) / (2.00)]^{**0.2} = 4.290$
COMPUTED TIME OF CONCENTRATION INCREASED TO 5 MIN.
10 YEAR RAINFALL INTENSITY(INCH/HOUR) = 3.163
APARTMENT DEVELOPMENT RUNOFF COEFFICIENT = .8713
SOIL CLASSIFICATION IS "C"
SUBAREA RUNOFF(CFS) = 0.55
TOTAL AREA(ACRES) = 0.20 TOTAL RUNOFF(CFS) = 0.55

FLOW PROCESS FROM NODE 7.00 TO NODE 5.00 IS CODE = 41

>>>>COMPUTE PIPE-FLOW TRAVEL TIME THRU SUBAREA<<<<<
>>>>USING USER-SPECIFIED PIPESIZE (EXISTING ELEMENT)<<<<<

=====

REPRESENTATIVE SLOPE = 0.0100
FLOW LENGTH(FEET) = 12.57 MANNING'S N = 0.009
ASSUME FULL-FLOWING PIPELINE
PIPE-FLOW VELOCITY(FEET/SEC.) = 6.35
PIPE FLOW VELOCITY = (TOTAL FLOW)/(PIPE CROSS SECTION AREA)
GIVEN PIPE DIAMETER(INCH) = 4.00 NUMBER OF PIPES = 1
PIPE-FLOW(CFS) = 0.55
PIPE TRAVEL TIME(MIN.) = 0.03 Tc(MIN.) = 5.03
LONGEST FLOWPATH FROM NODE 6.00 TO NODE 5.00 = 106.57 FEET.

FLOW PROCESS FROM NODE 5.00 TO NODE 5.00 IS CODE = 11

>>>>CONFLUENCE MEMORY BANK # 2 WITH THE MAIN-STREAM MEMORY<<<<<

=====

** MAIN STREAM CONFLUENCE DATA **

STREAM NUMBER	RUNOFF (CFS)	Tc (MIN.)	INTENSITY (INCH/HOUR)	AREA (ACRE)
1	0.55	5.03	3.151	0.20

LONGEST FLOWPATH FROM NODE 6.00 TO NODE 5.00 = 106.57 FEET.

** MEMORY BANK # 2 CONFLUENCE DATA **

STREAM NUMBER	RUNOFF (CFS)	Tc (MIN.)	INTENSITY (INCH/HOUR)	AREA (ACRE)
---------------	--------------	-----------	-----------------------	-------------

1 0.67 5.27 3.072 0.24
LONGEST FLOWPATH FROM NODE 3.00 TO NODE 5.00 = 167.03 FEET.

** PEAK FLOW RATE TABLE **

STREAM NUMBER	RUNOFF (CFS)	Tc (MIN.)	INTENSITY (INCH/HOUR)
1	1.19	5.03	3.151
2	1.21	5.27	3.072

COMPUTED CONFLUENCE ESTIMATES ARE AS FOLLOWS:

PEAK FLOW RATE(CFS) = 1.21 Tc(MIN.) = 5.27
TOTAL AREA(ACRES) = 0.4

FLOW PROCESS FROM NODE 5.00 TO NODE 5.00 IS CODE = 12

>>>>>CLEAR MEMORY BANK # 2 <<<<<<

FLOW PROCESS FROM NODE 7.10 TO NODE 7.10 IS CODE = 81

>>>>>ADDITION OF SUBAREA TO MAINLINE PEAK FLOW<<<<<<

=====

10 YEAR RAINFALL INTENSITY(INCH/HOUR) = 3.072
UNDEVELOPED WATERSHED RUNOFF COEFFICIENT = .7531
SOIL CLASSIFICATION IS "C"
SUBAREA AREA(ACRES) = 0.10 SUBAREA RUNOFF(CFS) = 0.24
TOTAL AREA(ACRES) = 0.5 TOTAL RUNOFF(CFS) = 1.45
TC(MIN.) = 5.27

FLOW PROCESS FROM NODE 5.00 TO NODE 2.00 IS CODE = 41

>>>>>COMPUTE PIPE-FLOW TRAVEL TIME THRU SUBAREA<<<<<<
>>>>>USING USER-SPECIFIED PIPESIZE (EXISTING ELEMENT)<<<<<<

=====

REPRESENTATIVE SLOPE = 0.0100
FLOW LENGTH(FEET) = 78.38 MANNING'S N = 0.009
DEPTH OF FLOW IN 8.0 INCH PIPE IS 5.7 INCHES
PIPE-FLOW VELOCITY(FEET/SEC.) = 5.47
GIVEN PIPE DIAMETER(INCH) = 8.00 NUMBER OF PIPES = 1
PIPE-FLOW(CFS) = 1.45
PIPE TRAVEL TIME(MIN.) = 0.24 Tc(MIN.) = 5.51
LONGEST FLOWPATH FROM NODE 3.00 TO NODE 2.00 = 245.41 FEET.

FLOW PROCESS FROM NODE 2.00 TO NODE 2.00 IS CODE = 11

>>>>>CONFLUENCE MEMORY BANK # 1 WITH THE MAIN-STREAM MEMORY<<<<<<

=====
** MAIN STREAM CONFLUENCE DATA **

STREAM NUMBER	RUNOFF (CFS)	Tc (MIN.)	INTENSITY (INCH/HOUR)	AREA (ACRE)
1	1.44	5.27	3.072	0.55
2	1.45	5.51	2.998	0.55

LONGEST FLOWPATH FROM NODE 3.00 TO NODE 2.00 = 245.41 FEET.

** MEMORY BANK # 1 CONFLUENCE DATA **

STREAM NUMBER	RUNOFF (CFS)	Tc (MIN.)	INTENSITY (INCH/HOUR)	AREA (ACRE)
1	0.99	5.29	3.066	0.37

LONGEST FLOWPATH FROM NODE 1.00 TO NODE 2.00 = 124.00 FEET.

** PEAK FLOW RATE TABLE **

STREAM NUMBER	RUNOFF (CFS)	Tc (MIN.)	INTENSITY (INCH/HOUR)
1	2.42	5.27	3.072
2	2.42	5.29	3.066
3	2.41	5.51	2.998

COMPUTED CONFLUENCE ESTIMATES ARE AS FOLLOWS:

PEAK FLOW RATE(CFS) = 2.42 Tc(MIN.) = 5.29
TOTAL AREA(ACRES) = 0.9

FLOW PROCESS FROM NODE 2.00 TO NODE 2.00 IS CODE = 12

>>>>>CLEAR MEMORY BANK # 1 <<<<<<

FLOW PROCESS FROM NODE 2.00 TO NODE 8.00 IS CODE = 41

>>>>>COMPUTE PIPE-FLOW TRAVEL TIME THRU SUBAREA<<<<<<
>>>>>USING USER-SPECIFIED PIPESIZE (EXISTING ELEMENT)<<<<<<

=====
REPRESENTATIVE SLOPE = 0.0100
FLOW LENGTH(FEET) = 145.73 MANNING'S N = 0.009
DEPTH OF FLOW IN 10.0 INCH PIPE IS 6.7 INCHES
PIPE-FLOW VELOCITY(FEET/SEC.) = 6.27
GIVEN PIPE DIAMETER(INCH) = 10.00 NUMBER OF PIPES = 1
PIPE-FLOW(CFS) = 2.42
PIPE TRAVEL TIME(MIN.) = 0.39 Tc(MIN.) = 5.68
LONGEST FLOWPATH FROM NODE 3.00 TO NODE 8.00 = 391.14 FEET.

FLOW PROCESS FROM NODE 8.00 TO NODE 8.00 IS CODE = 10

>>>>MAIN-STREAM MEMORY COPIED ONTO MEMORY BANK # 1 <<<<<

FLOW PROCESS FROM NODE 8.00 TO NODE 8.00 IS CODE = 13

>>>>CLEAR THE MAIN-STREAM MEMORY<<<<<

FLOW PROCESS FROM NODE 9.00 TO NODE 10.00 IS CODE = 21

>>>>RATIONAL METHOD INITIAL SUBAREA ANALYSIS<<<<<

ASSUMED INITIAL SUBAREA UNIFORM
DEVELOPMENT IS APARTMENT

$TC = K * [(LENGTH^{**3}) / (ELEVATION CHANGE)]^{**.2}$
INITIAL SUBAREA FLOW-LENGTH(FEET) = 71.61
UPSTREAM ELEVATION(FEET) = 15.00
DOWNSTREAM ELEVATION(FEET) = 13.00
ELEVATION DIFFERENCE(FEET) = 2.00
 $TC = 0.323 * [(71.61^{**3}) / (2.00)]^{**.2} = 3.644$
COMPUTED TIME OF CONCENTRATION INCREASED TO 5 MIN.
10 YEAR RAINFALL INTENSITY(INCH/HOUR) = 3.163
APARTMENT DEVELOPMENT RUNOFF COEFFICIENT = .8713
SOIL CLASSIFICATION IS "C"
SUBAREA RUNOFF(CFS) = 0.56
TOTAL AREA(ACRES) = 0.20 TOTAL RUNOFF(CFS) = 0.56

FLOW PROCESS FROM NODE 10.00 TO NODE 10.10 IS CODE = 41

>>>>COMPUTE PIPE-FLOW TRAVEL TIME THRU SUBAREA<<<<<
>>>>USING USER-SPECIFIED PIPESIZE (EXISTING ELEMENT)<<<<<

REPRESENTATIVE SLOPE = 0.0100
FLOW LENGTH(FEET) = 45.35 MANNING'S N = 0.009
ASSUME FULL-FLOWING PIPELINE
PIPE-FLOW VELOCITY(FEET/SEC.) = 6.41
PIPE FLOW VELOCITY = (TOTAL FLOW) / (PIPE CROSS SECTION AREA)
GIVEN PIPE DIAMETER(INCH) = 4.00 NUMBER OF PIPES = 1
PIPE-FLOW(CFS) = 0.56
PIPE TRAVEL TIME(MIN.) = 0.12 $T_c(MIN.) = 5.12$
LONGEST FLOWPATH FROM NODE 9.00 TO NODE 10.10 = 116.96 FEET.

FLOW PROCESS FROM NODE 10.10 TO NODE 10.20 IS CODE = 41

>>>>COMPUTE PIPE-FLOW TRAVEL TIME THRU SUBAREA<<<<<
>>>>USING USER-SPECIFIED PIPESIZE (EXISTING ELEMENT)<<<<<

=====

REPRESENTATIVE SLOPE = 0.0100
FLOW LENGTH(FEET) = 37.68 MANNING'S N = 0.009
DEPTH OF FLOW IN 6.0 INCH PIPE IS 3.7 INCHES
PIPE-FLOW VELOCITY(FEET/SEC.) = 4.34
GIVEN PIPE DIAMETER(INCH) = 6.00 NUMBER OF PIPES = 1
PIPE-FLOW(CFS) = 0.56
PIPE TRAVEL TIME(MIN.) = 0.14 Tc(MIN.) = 5.26
LONGEST FLOWPATH FROM NODE 9.00 TO NODE 10.20 = 154.64 FEET.

FLOW PROCESS FROM NODE 10.20 TO NODE 10.20 IS CODE = 10

>>>>MAIN-STREAM MEMORY COPIED ONTO MEMORY BANK # 3 <<<<<

FLOW PROCESS FROM NODE 10.20 TO NODE 10.20 IS CODE = 13

>>>>CLEAR THE MAIN-STREAM MEMORY<<<<<

FLOW PROCESS FROM NODE 10.30 TO NODE 10.40 IS CODE = 21

>>>>RATIONAL METHOD INITIAL SUBAREA ANALYSIS<<<<<

=====

ASSUMED INITIAL SUBAREA UNIFORM
DEVELOPMENT IS: UNDEVELOPED WITH GOOD COVER
TC = K*[(LENGTH**3)/(ELEVATION CHANGE)]**.2
INITIAL SUBAREA FLOW-LENGTH(FEET) = 17.00
UPSTREAM ELEVATION(FEET) = 878.70
DOWNSTREAM ELEVATION(FEET) = 878.32
ELEVATION DIFFERENCE(FEET) = 0.38
TC = 0.937*[(17.00**3)/(0.38)]**.2 = 6.226
10 YEAR RAINFALL INTENSITY(INCH/HOUR) = 2.804
UNDEVELOPED WATERSHED RUNOFF COEFFICIENT = .7416
SOIL CLASSIFICATION IS "C"
SUBAREA RUNOFF(CFS) = 0.17
TOTAL AREA(ACRES) = 0.08 TOTAL RUNOFF(CFS) = 0.17

FLOW PROCESS FROM NODE 10.40 TO NODE 10.20 IS CODE = 41

>>>>COMPUTE PIPE-FLOW TRAVEL TIME THRU SUBAREA<<<<<
>>>>USING USER-SPECIFIED PIPESIZE (EXISTING ELEMENT)<<<<<

=====

REPRESENTATIVE SLOPE = 0.0100
FLOW LENGTH(FEET) = 8.88 MANNING'S N = 0.009
DEPTH OF FLOW IN 4.0 INCH PIPE IS 2.4 INCHES

PIPE-FLOW VELOCITY(FEET/SEC.) = 3.20
GIVEN PIPE DIAMETER(INCH) = 4.00 NUMBER OF PIPES = 1
PIPE-FLOW(CFS) = 0.17
PIPE TRAVEL TIME(MIN.) = 0.05 Tc(MIN.) = 6.27
LONGEST FLOWPATH FROM NODE 10.30 TO NODE 10.20 = 25.88 FEET.

FLOW PROCESS FROM NODE 10.20 TO NODE 10.20 IS CODE = 11

>>>>CONFLUENCE MEMORY BANK # 3 WITH THE MAIN-STREAM MEMORY<<<<<

** MAIN STREAM CONFLUENCE DATA **

STREAM NUMBER	RUNOFF (CFS)	Tc (MIN.)	INTENSITY (INCH/HOUR)	AREA (ACRE)
1	0.17	6.27	2.792	0.08

LONGEST FLOWPATH FROM NODE 10.30 TO NODE 10.20 = 25.88 FEET.

** MEMORY BANK # 3 CONFLUENCE DATA **

STREAM NUMBER	RUNOFF (CFS)	Tc (MIN.)	INTENSITY (INCH/HOUR)	AREA (ACRE)
1	0.56	5.26	3.075	0.20

LONGEST FLOWPATH FROM NODE 9.00 TO NODE 10.20 = 154.64 FEET.

** PEAK FLOW RATE TABLE **

STREAM NUMBER	RUNOFF (CFS)	Tc (MIN.)	INTENSITY (INCH/HOUR)
1	0.71	5.26	3.075
2	0.68	6.27	2.792

COMPUTED CONFLUENCE ESTIMATES ARE AS FOLLOWS:

PEAK FLOW RATE(CFS) = 0.71 Tc(MIN.) = 5.26
TOTAL AREA(ACRES) = 0.3

FLOW PROCESS FROM NODE 10.20 TO NODE 10.20 IS CODE = 12

>>>>CLEAR MEMORY BANK # 3 <<<<<

FLOW PROCESS FROM NODE 10.20 TO NODE 10.50 IS CODE = 41

>>>>COMPUTE PIPE-FLOW TRAVEL TIME THRU SUBAREA<<<<<
>>>>USING USER-SPECIFIED PIPESIZE (EXISTING ELEMENT)<<<<<

REPRESENTATIVE SLOPE = 0.0100
FLOW LENGTH(FEET) = 131.52 MANNING'S N = 0.009
DEPTH OF FLOW IN 6.0 INCH PIPE IS 4.4 INCHES
PIPE-FLOW VELOCITY(FEET/SEC.) = 4.54

GIVEN PIPE DIAMETER(INCH) = 6.00 NUMBER OF PIPES = 1
 PIPE-FLOW(CFS) = 0.71
 PIPE TRAVEL TIME(MIN.) = 0.48 Tc(MIN.) = 5.75
 LONGEST FLOWPATH FROM NODE 9.00 TO NODE 10.50 = 286.16 FEET.

FLOW PROCESS FROM NODE 10.50 TO NODE 10.50 IS CODE = 81

>>>>ADDITION OF SUBAREA TO MAINLINE PEAK FLOW<<<<<

=====

10 YEAR RAINFALL INTENSITY(INCH/HOUR) = 2.930
 UNDEVELOPED WATERSHED RUNOFF COEFFICIENT = .7472
 SOIL CLASSIFICATION IS "C"
 SUBAREA AREA(ACRES) = 0.10 SUBAREA RUNOFF(CFS) = 0.22
 TOTAL AREA(ACRES) = 0.4 TOTAL RUNOFF(CFS) = 0.92
 TC(MIN.) = 5.75

FLOW PROCESS FROM NODE 10.50 TO NODE 8.00 IS CODE = 41

>>>>COMPUTE PIPE-FLOW TRAVEL TIME THRU SUBAREA<<<<<
 >>>>USING USER-SPECIFIED PIPESIZE (EXISTING ELEMENT)<<<<<

=====

REPRESENTATIVE SLOPE = 0.0100
 FLOW LENGTH(FEET) = 137.41 MANNING'S N = 0.009
 DEPTH OF FLOW IN 8.0 INCH PIPE IS 4.2 INCHES
 PIPE-FLOW VELOCITY(FEET/SEC.) = 4.99
 GIVEN PIPE DIAMETER(INCH) = 8.00 NUMBER OF PIPES = 1
 PIPE-FLOW(CFS) = 0.92
 PIPE TRAVEL TIME(MIN.) = 0.46 Tc(MIN.) = 6.20
 LONGEST FLOWPATH FROM NODE 9.00 TO NODE 8.00 = 423.57 FEET.

FLOW PROCESS FROM NODE 8.00 TO NODE 8.00 IS CODE = 11

>>>>CONFLUENCE MEMORY BANK # 1 WITH THE MAIN-STREAM MEMORY<<<<<

** MAIN STREAM CONFLUENCE DATA **

STREAM NUMBER	RUNOFF (CFS)	Tc (MIN.)	INTENSITY (INCH/HOUR)	AREA (ACRE)
1	0.92	6.20	2.809	0.39
2	0.88	7.22	2.584	0.39

LONGEST FLOWPATH FROM NODE 9.00 TO NODE 8.00 = 423.57 FEET.

** MEMORY BANK # 1 CONFLUENCE DATA **

STREAM NUMBER	RUNOFF (CFS)	Tc (MIN.)	INTENSITY (INCH/HOUR)	AREA (ACRE)
1	2.42	5.66	2.955	0.92
2	2.42	5.68	2.949	0.92

3 2.41 5.90 2.889 0.92
LONGEST FLOWPATH FROM NODE 3.00 TO NODE 8.00 = 391.14 FEET.

** PEAK FLOW RATE TABLE **

STREAM NUMBER	RUNOFF (CFS)	Tc (MIN.)	INTENSITY (INCH/HOUR)
1	3.26	5.66	2.955
2	3.27	5.68	2.949
3	3.29	5.90	2.889
4	3.27	6.20	2.809
5	3.04	7.22	2.584

COMPUTED CONFLUENCE ESTIMATES ARE AS FOLLOWS:

PEAK FLOW RATE(CFS) = 3.29 Tc(MIN.) = 5.90
TOTAL AREA(ACRES) = 1.3

FLOW PROCESS FROM NODE 8.00 TO NODE 8.00 IS CODE = 12

>>>>CLEAR MEMORY BANK # 1 <<<<<

FLOW PROCESS FROM NODE 8.00 TO NODE 13.00 IS CODE = 41

>>>>COMPUTE PIPE-FLOW TRAVEL TIME THRU SUBAREA<<<<<
>>>>USING USER-SPECIFIED PIPESIZE (EXISTING ELEMENT)<<<<<

REPRESENTATIVE SLOPE = 0.0100
FLOW LENGTH(FEET) = 38.12 MANNING'S N = 0.009
ASSUME FULL-FLOWING PIPELINE
PIPE-FLOW VELOCITY(FEET/SEC.) = 6.03
PIPE FLOW VELOCITY = (TOTAL FLOW)/(PIPE CROSS SECTION AREA)
GIVEN PIPE DIAMETER(INCH) = 10.00 NUMBER OF PIPES = 1
PIPE-FLOW(CFS) = 3.29
PIPE TRAVEL TIME(MIN.) = 0.11 Tc(MIN.) = 6.00
LONGEST FLOWPATH FROM NODE 9.00 TO NODE 13.00 = 461.69 FEET.

FLOW PROCESS FROM NODE 13.00 TO NODE 13.00 IS CODE = 10

>>>>MAIN-STREAM MEMORY COPIED ONTO MEMORY BANK # 1 <<<<<

FLOW PROCESS FROM NODE 13.00 TO NODE 13.00 IS CODE = 13

>>>>CLEAR THE MAIN-STREAM MEMORY<<<<<

FLOW PROCESS FROM NODE 11.00 TO NODE 12.00 IS CODE = 21

>>>>RATIONAL METHOD INITIAL SUBAREA ANALYSIS<<<<<

ASSUMED INITIAL SUBAREA UNIFORM DEVELOPMENT IS APARTMENT

TC = K*[(LENGTH**3)/(ELEVATION CHANGE)]**.2
INITIAL SUBAREA FLOW-LENGTH(FEET) = 36.94
UPSTREAM ELEVATION(FEET) = 15.00
DOWNSTREAM ELEVATION(FEET) = 13.00
ELEVATION DIFFERENCE(FEET) = 2.00
TC = 0.323*[(36.94**3)/(2.00)]**.2 = 2.450
COMPUTED TIME OF CONCENTRATION INCREASED TO 5 MIN.
10 YEAR RAINFALL INTENSITY(INCH/HOUR) = 3.163
APARTMENT DEVELOPMENT RUNOFF COEFFICIENT = .8713
SOIL CLASSIFICATION IS "C"
SUBAREA RUNOFF(CFS) = 0.14
TOTAL AREA(ACRES) = 0.05 TOTAL RUNOFF(CFS) = 0.14

FLOW PROCESS FROM NODE 12.00 TO NODE 13.00 IS CODE = 41

>>>>COMPUTE PIPE-FLOW TRAVEL TIME THRU SUBAREA<<<<<
>>>>USING USER-SPECIFIED PIPESIZE (EXISTING ELEMENT)<<<<<

REPRESENTATIVE SLOPE = 0.0100
FLOW LENGTH(FEET) = 41.32 MANNING'S N = 0.009
DEPTH OF FLOW IN 4.0 INCH PIPE IS 2.0 INCHES
PIPE-FLOW VELOCITY(FEET/SEC.) = 3.07
GIVEN PIPE DIAMETER(INCH) = 4.00 NUMBER OF PIPES = 1
PIPE-FLOW(CFS) = 0.14
PIPE TRAVEL TIME(MIN.) = 0.22 Tc(MIN.) = 5.22
LONGEST FLOWPATH FROM NODE 11.00 TO NODE 13.00 = 78.26 FEET.

FLOW PROCESS FROM NODE 13.00 TO NODE 13.00 IS CODE = 11

>>>>CONFLUENCE MEMORY BANK # 1 WITH THE MAIN-STREAM MEMORY<<<<<

** MAIN STREAM CONFLUENCE DATA **

STREAM RUNOFF Tc INTENSITY AREA
NUMBER (CFS) (MIN.) (INCH/HOUR) (ACRE)
1 0.14 5.22 3.087 0.05
LONGEST FLOWPATH FROM NODE 11.00 TO NODE 13.00 = 78.26 FEET.

** MEMORY BANK # 1 CONFLUENCE DATA **

STREAM RUNOFF Tc INTENSITY AREA
NUMBER (CFS) (MIN.) (INCH/HOUR) (ACRE)

1	3.26	5.77	2.925	1.30
2	3.27	5.78	2.920	1.30
3	3.29	6.00	2.861	1.30
4	3.27	6.31	2.783	1.30
5	3.04	7.32	2.565	1.30

LONGEST FLOWPATH FROM NODE 9.00 TO NODE 13.00 = 461.69 FEET.

** PEAK FLOW RATE TABLE **

STREAM NUMBER	RUNOFF (CFS)	Tc (MIN.)	INTENSITY (INCH/HOUR)
1	3.10	5.22	3.087
2	3.39	5.77	2.925
3	3.40	5.78	2.920
4	3.42	6.00	2.861
5	3.39	6.31	2.783
6	3.15	7.32	2.565

COMPUTED CONFLUENCE ESTIMATES ARE AS FOLLOWS:

PEAK FLOW RATE(CFS) = 3.42 Tc(MIN.) = 6.00
TOTAL AREA(ACRES) = 1.4

FLOW PROCESS FROM NODE 13.00 TO NODE 13.00 IS CODE = 12

>>>>CLEAR MEMORY BANK # 1 <<<<<

FLOW PROCESS FROM NODE 13.00 TO NODE 13.00 IS CODE = 10

>>>>MAIN-STREAM MEMORY COPIED ONTO MEMORY BANK # 1 <<<<<

FLOW PROCESS FROM NODE 13.00 TO NODE 13.00 IS CODE = 13

>>>>CLEAR THE MAIN-STREAM MEMORY<<<<<

FLOW PROCESS FROM NODE 14.00 TO NODE 15.00 IS CODE = 21

>>>>RATIONAL METHOD INITIAL SUBAREA ANALYSIS<<<<<

=====

ASSUMED INITIAL SUBAREA UNIFORM
DEVELOPMENT IS APARTMENT

TC = K*[(LENGTH**3)/(ELEVATION CHANGE)]**.2
INITIAL SUBAREA FLOW-LENGTH(FEET) = 282.36
UPSTREAM ELEVATION(FEET) = 881.50
DOWNSTREAM ELEVATION(FEET) = 877.80

ELEVATION DIFFERENCE(FEET) = 3.70
 $TC = 0.323 * [(282.36^{**3}) / (3.70)]^{**0.2} = 7.339$
 10 YEAR RAINFALL INTENSITY(INCH/HOUR) = 2.562
 APARTMENT DEVELOPMENT RUNOFF COEFFICIENT = .8659
 SOIL CLASSIFICATION IS "C"
 SUBAREA RUNOFF(CFS) = 2.93
 TOTAL AREA(ACRES) = 1.32 TOTAL RUNOFF(CFS) = 2.93

 FLOW PROCESS FROM NODE 15.00 TO NODE 15.00 IS CODE = 11

 >>>>CONFLUENCE MEMORY BANK # 1 WITH THE MAIN-STREAM MEMORY<<<<<
 =====

** MAIN STREAM CONFLUENCE DATA **

STREAM NUMBER	RUNOFF (CFS)	Tc (MIN.)	INTENSITY (INCH/HOUR)	AREA (ACRE)
1	2.93	7.34	2.562	1.32

LONGEST FLOWPATH FROM NODE 14.00 TO NODE 15.00 = 282.36 FEET.

** MEMORY BANK # 1 CONFLUENCE DATA **

STREAM NUMBER	RUNOFF (CFS)	Tc (MIN.)	INTENSITY (INCH/HOUR)	AREA (ACRE)
1	3.10	5.22	3.087	1.35
2	3.39	5.77	2.925	1.35
3	3.40	5.78	2.920	1.35
4	3.42	6.00	2.861	1.35
5	3.39	6.31	2.783	1.35
6	3.15	7.32	2.565	1.35

LONGEST FLOWPATH FROM NODE 9.00 TO NODE 15.00 = 461.69 FEET.

** PEAK FLOW RATE TABLE **

STREAM NUMBER	RUNOFF (CFS)	Tc (MIN.)	INTENSITY (INCH/HOUR)
1	5.18	5.22	3.087
2	5.70	5.77	2.925
3	5.71	5.78	2.920
4	5.82	6.00	2.861
5	5.92	6.31	2.783
6	6.08	7.32	2.565
7	6.08	7.34	2.562

COMPUTED CONFLUENCE ESTIMATES ARE AS FOLLOWS:

PEAK FLOW RATE(CFS) = 6.08 Tc(MIN.) = 7.34
 TOTAL AREA(ACRES) = 2.7

 FLOW PROCESS FROM NODE 15.00 TO NODE 15.00 IS CODE = 12

 >>>>CLEAR MEMORY BANK # 1 <<<<<

=====

FLOW PROCESS FROM NODE 15.00 TO NODE 15.00 IS CODE = 10

>>>>MAIN-STREAM MEMORY COPIED ONTO MEMORY BANK # 1 <<<<<

=====

FLOW PROCESS FROM NODE 15.00 TO NODE 15.00 IS CODE = 13

>>>>CLEAR THE MAIN-STREAM MEMORY<<<<<

=====

FLOW PROCESS FROM NODE 16.00 TO NODE 17.00 IS CODE = 21

>>>>RATIONAL METHOD INITIAL SUBAREA ANALYSIS<<<<<

=====

ASSUMED INITIAL SUBAREA UNIFORM
DEVELOPMENT IS APARTMENT

TC = K*[(LENGTH**3)/(ELEVATION CHANGE)]**.2
INITIAL SUBAREA FLOW-LENGTH(FEET) = 74.23
UPSTREAM ELEVATION(FEET) = 15.00
DOWNSTREAM ELEVATION(FEET) = 13.00
ELEVATION DIFFERENCE(FEET) = 2.00
TC = 0.323*[(74.23**3)/(2.00)]**.2 = 3.723
COMPUTED TIME OF CONCENTRATION INCREASED TO 5 MIN.
10 YEAR RAINFALL INTENSITY(INCH/HOUR) = 3.163
APARTMENT DEVELOPMENT RUNOFF COEFFICIENT = .8713
SOIL CLASSIFICATION IS "C"
SUBAREA RUNOFF(CFS) = 0.80
TOTAL AREA(ACRES) = 0.29 TOTAL RUNOFF(CFS) = 0.80

FLOW PROCESS FROM NODE 17.00 TO NODE 17.10 IS CODE = 41

>>>>COMPUTE PIPE-FLOW TRAVEL TIME THRU SUBAREA<<<<<
>>>>USING USER-SPECIFIED PIPESIZE (EXISTING ELEMENT)<<<<<

=====

REPRESENTATIVE SLOPE = 0.0100
FLOW LENGTH(FEET) = 15.20 MANNING'S N = 0.009
ASSUME FULL-FLOWING PIPELINE
PIPE-FLOW VELOCITY(FEET/SEC.) = 9.13
PIPE FLOW VELOCITY = (TOTAL FLOW)/(PIPE CROSS SECTION AREA)
GIVEN PIPE DIAMETER(INCH) = 4.00 NUMBER OF PIPES = 1
PIPE-FLOW(CFS) = 0.80
PIPE TRAVEL TIME(MIN.) = 0.03 Tc(MIN.) = 5.03
LONGEST FLOWPATH FROM NODE 16.00 TO NODE 17.10 = 89.43 FEET.

FLOW PROCESS FROM NODE 17.00 TO NODE 18.00 IS CODE = 41

>>>>COMPUTE PIPE-FLOW TRAVEL TIME THRU SUBAREA<<<<<
>>>>USING USER-SPECIFIED PIPESIZE (EXISTING ELEMENT)<<<<<

=====

REPRESENTATIVE SLOPE =	0.0100		
FLOW LENGTH(FEET) =	164.51	MANNING'S N =	0.009
DEPTH OF FLOW IN	8.0 INCH PIPE IS	3.8 INCHES	
PIPE-FLOW VELOCITY(FEET/SEC.) =	4.81		
GIVEN PIPE DIAMETER(INCH) =	8.00	NUMBER OF PIPES =	1
PIPE-FLOW(CFS) =	0.80		
PIPE TRAVEL TIME(MIN.) =	0.57	Tc(MIN.) =	5.60
LONGEST FLOWPATH FROM NODE	16.00 TO NODE	18.00 =	253.94 FEET.

FLOW PROCESS FROM NODE 18.00 TO NODE 18.00 IS CODE = 10

>>>>MAIN-STREAM MEMORY COPIED ONTO MEMORY BANK # 2 <<<<<

FLOW PROCESS FROM NODE 18.00 TO NODE 18.00 IS CODE = 13

>>>>CLEAR THE MAIN-STREAM MEMORY<<<<<

FLOW PROCESS FROM NODE 19.00 TO NODE 20.00 IS CODE = 21

>>>>RATIONAL METHOD INITIAL SUBAREA ANALYSIS<<<<<

=====

ASSUMED INITIAL SUBAREA UNIFORM
DEVELOPMENT IS APARTMENT

$TC = K * [(LENGTH^{**3}) / (ELEVATION CHANGE)]^{**0.2}$
INITIAL SUBAREA FLOW-LENGTH(FEET) = 147.00
UPSTREAM ELEVATION(FEET) = 881.00
DOWNSTREAM ELEVATION(FEET) = 878.08
ELEVATION DIFFERENCE(FEET) = 2.92
 $TC = 0.323 * [(147.00^{**3}) / (2.92)]^{**0.2} = 5.201$
10 YEAR RAINFALL INTENSITY(INCH/HOUR) = 3.095
APARTMENT DEVELOPMENT RUNOFF COEFFICIENT = .8708
SOIL CLASSIFICATION IS "C"
SUBAREA RUNOFF(CFS) = 0.85
TOTAL AREA(ACRES) = 0.31 TOTAL RUNOFF(CFS) = 0.85

FLOW PROCESS FROM NODE 20.00 TO NODE 20.00 IS CODE = 11

>>>>CONFLUENCE MEMORY BANK # 2 WITH THE MAIN-STREAM MEMORY<<<<<

=====
** MAIN STREAM CONFLUENCE DATA **

STREAM NUMBER	RUNOFF (CFS)	Tc (MIN.)	INTENSITY (INCH/HOUR)	AREA (ACRE)
1	0.85	5.20	3.095	0.31

LONGEST FLOWPATH FROM NODE 19.00 TO NODE 20.00 = 147.00 FEET.

** MEMORY BANK # 2 CONFLUENCE DATA **

STREAM NUMBER	RUNOFF (CFS)	Tc (MIN.)	INTENSITY (INCH/HOUR)	AREA (ACRE)
1	0.80	5.60	2.972	0.29

LONGEST FLOWPATH FROM NODE 16.00 TO NODE 20.00 = 253.94 FEET.

** PEAK FLOW RATE TABLE **

STREAM NUMBER	RUNOFF (CFS)	Tc (MIN.)	INTENSITY (INCH/HOUR)
1	1.59	5.20	3.095
2	1.61	5.60	2.972

COMPUTED CONFLUENCE ESTIMATES ARE AS FOLLOWS:

PEAK FLOW RATE(CFS) = 1.61 Tc(MIN.) = 5.60
TOTAL AREA(ACRES) = 0.6

FLOW PROCESS FROM NODE 20.00 TO NODE 20.00 IS CODE = 12

>>>>CLEAR MEMORY BANK # 2 <<<<<

FLOW PROCESS FROM NODE 20.00 TO NODE 21.00 IS CODE = 41

>>>>COMPUTE PIPE-FLOW TRAVEL TIME THRU SUBAREA<<<<<
>>>>USING USER-SPECIFIED PIPESIZE (EXISTING ELEMENT)<<<<<

REPRESENTATIVE SLOPE = 0.0100
FLOW LENGTH(FEET) = 35.92 MANNING'S N = 0.009
ASSUME FULL-FLOWING PIPELINE
PIPE-FLOW VELOCITY(FEET/SEC.) = 8.21
PIPE FLOW VELOCITY = (TOTAL FLOW)/(PIPE CROSS SECTION AREA)
GIVEN PIPE DIAMETER(INCH) = 6.00 NUMBER OF PIPES = 1
PIPE-FLOW(CFS) = 1.61
PIPE TRAVEL TIME(MIN.) = 0.07 Tc(MIN.) = 5.67
LONGEST FLOWPATH FROM NODE 16.00 TO NODE 21.00 = 289.86 FEET.

FLOW PROCESS FROM NODE 21.00 TO NODE 21.00 IS CODE = 10

>>>>MAIN-STREAM MEMORY COPIED ONTO MEMORY BANK # 2 <<<<<

FLOW PROCESS FROM NODE 21.00 TO NODE 21.00 IS CODE = 13

>>>>CLEAR THE MAIN-STREAM MEMORY<<<<<

FLOW PROCESS FROM NODE 22.00 TO NODE 23.00 IS CODE = 21

>>>>RATIONAL METHOD INITIAL SUBAREA ANALYSIS<<<<<

ASSUMED INITIAL SUBAREA UNIFORM
DEVELOPMENT IS: UNDEVELOPED WITH GOOD COVER
TC = $K * [(LENGTH^{**3}) / (ELEVATION CHANGE)]^{**.2}$
INITIAL SUBAREA FLOW-LENGTH(FEET) = 77.86
UPSTREAM ELEVATION(FEET) = 881.47
DOWNSTREAM ELEVATION(FEET) = 880.67
ELEVATION DIFFERENCE(FEET) = 0.80
TC = $0.937 * [(77.86^{**3}) / (0.80)]^{**.2} = 13.369$
10 YEAR RAINFALL INTENSITY(INCH/HOUR) = 1.843
UNDEVELOPED WATERSHED RUNOFF COEFFICIENT = .6792
SOIL CLASSIFICATION IS "C"
SUBAREA RUNOFF(CFS) = 0.13
TOTAL AREA(ACRES) = 0.10 TOTAL RUNOFF(CFS) = 0.13

FLOW PROCESS FROM NODE 23.00 TO NODE 21.00 IS CODE = 41

>>>>COMPUTE PIPE-FLOW TRAVEL TIME THRU SUBAREA<<<<<
>>>>USING USER-SPECIFIED PIPESIZE (EXISTING ELEMENT)<<<<<

REPRESENTATIVE SLOPE = 0.0100
FLOW LENGTH(FEET) = 107.21 MANNING'S N = 0.009
DEPTH OF FLOW IN 6.0 INCH PIPE IS 1.6 INCHES
PIPE-FLOW VELOCITY(FEET/SEC.) = 2.93
GIVEN PIPE DIAMETER(INCH) = 6.00 NUMBER OF PIPES = 1
PIPE-FLOW(CFS) = 0.13
PIPE TRAVEL TIME(MIN.) = 0.61 Tc(MIN.) = 13.98
LONGEST FLOWPATH FROM NODE 22.00 TO NODE 21.00 = 185.07 FEET.

FLOW PROCESS FROM NODE 21.00 TO NODE 21.00 IS CODE = 11

>>>>CONFLUENCE MEMORY BANK # 2 WITH THE MAIN-STREAM MEMORY<<<<<

** MAIN STREAM CONFLUENCE DATA **
STREAM RUNOFF Tc INTENSITY AREA

NUMBER	(CFS)	(MIN.)	(INCH/HOUR)	(ACRE)
1	0.13	13.98	1.798	0.10

LONGEST FLOWPATH FROM NODE 22.00 TO NODE 21.00 = 185.07 FEET.

** MEMORY BANK # 2 CONFLUENCE DATA **

STREAM NUMBER	RUNOFF (CFS)	Tc (MIN.)	INTENSITY (INCH/HOUR)	AREA (ACRE)
1	1.59	5.28	3.071	0.60
2	1.61	5.67	2.951	0.60

LONGEST FLOWPATH FROM NODE 16.00 TO NODE 21.00 = 289.86 FEET.

** PEAK FLOW RATE TABLE **

STREAM NUMBER	RUNOFF (CFS)	Tc (MIN.)	INTENSITY (INCH/HOUR)
1	1.64	5.28	3.071
2	1.66	5.67	2.951
3	1.11	13.98	1.798

COMPUTED CONFLUENCE ESTIMATES ARE AS FOLLOWS:

PEAK FLOW RATE(CFS) = 1.66 Tc(MIN.) = 5.67
TOTAL AREA(ACRES) = 0.7

FLOW PROCESS FROM NODE 21.00 TO NODE 21.00 IS CODE = 12

>>>>CLEAR MEMORY BANK # 2 <<<<<

FLOW PROCESS FROM NODE 21.00 TO NODE 24.00 IS CODE = 41

>>>>COMPUTE PIPE-FLOW TRAVEL TIME THRU SUBAREA<<<<<
>>>>USING USER-SPECIFIED PIPESIZE (EXISTING ELEMENT)<<<<<

=====

REPRESENTATIVE SLOPE = 0.0100
FLOW LENGTH(FEET) = 136.64 MANNING'S N = 0.009
ASSUME FULL-FLOWING PIPELINE
PIPE-FLOW VELOCITY(FEET/SEC.) = 8.47
PIPE FLOW VELOCITY = (TOTAL FLOW)/(PIPE CROSS SECTION AREA)
GIVEN PIPE DIAMETER(INCH) = 6.00 NUMBER OF PIPES = 1
PIPE-FLOW(CFS) = 1.66
PIPE TRAVEL TIME(MIN.) = 0.27 Tc(MIN.) = 5.94
LONGEST FLOWPATH FROM NODE 16.00 TO NODE 24.00 = 426.50 FEET.

FLOW PROCESS FROM NODE 24.00 TO NODE 24.00 IS CODE = 11

>>>>CONFLUENCE MEMORY BANK # 1 WITH THE MAIN-STREAM MEMORY<<<<<

=====

** MAIN STREAM CONFLUENCE DATA **

STREAM NUMBER	RUNOFF (CFS)	Tc (MIN.)	INTENSITY (INCH/HOUR)	AREA (ACRE)
1	1.64	5.55	2.987	0.70
2	1.66	5.94	2.877	0.70
3	1.11	14.38	1.770	0.70

LONGEST FLOWPATH FROM NODE 16.00 TO NODE 24.00 = 426.50 FEET.

** MEMORY BANK # 1 CONFLUENCE DATA **

STREAM NUMBER	RUNOFF (CFS)	Tc (MIN.)	INTENSITY (INCH/HOUR)	AREA (ACRE)
1	5.18	5.22	3.087	2.68
2	5.70	5.77	2.925	2.68
3	5.71	5.78	2.920	2.68
4	5.82	6.00	2.861	2.68
5	5.92	6.31	2.783	2.68
6	6.08	7.32	2.565	2.68
7	6.08	7.34	2.562	2.68

LONGEST FLOWPATH FROM NODE 9.00 TO NODE 24.00 = 461.69 FEET.

** PEAK FLOW RATE TABLE **

STREAM NUMBER	RUNOFF (CFS)	Tc (MIN.)	INTENSITY (INCH/HOUR)
1	6.73	5.22	3.087
2	7.12	5.55	2.987
3	7.31	5.77	2.925
4	7.33	5.78	2.920
5	7.42	5.94	2.877
6	7.47	6.00	2.861
7	7.53	6.31	2.783
8	7.56	7.32	2.565
9	7.56	7.34	2.562
10	5.31	14.38	1.770

COMPUTED CONFLUENCE ESTIMATES ARE AS FOLLOWS:

PEAK FLOW RATE(CFS) = 7.56 Tc(MIN.) = 7.34
TOTAL AREA(ACRES) = 3.4

FLOW PROCESS FROM NODE 24.00 TO NODE 24.00 IS CODE = 12

>>>>CLEAR MEMORY BANK # 1 <<<<<

FLOW PROCESS FROM NODE 24.00 TO NODE 25.00 IS CODE = 41

>>>>COMPUTE PIPE-FLOW TRAVEL TIME THRU SUBAREA<<<<<
>>>>USING USER-SPECIFIED PIPESIZE (EXISTING ELEMENT)<<<<<

REPRESENTATIVE SLOPE = 0.0100
FLOW LENGTH(FEET) = 55.93 MANNING'S N = 0.009
ASSUME FULL-FLOWING PIPELINE
PIPE-FLOW VELOCITY(FEET/SEC.) = 38.52
PIPE FLOW VELOCITY = (TOTAL FLOW)/(PIPE CROSS SECTION AREA)
GIVEN PIPE DIAMETER(INCH) = 6.00 NUMBER OF PIPES = 1
PIPE-FLOW(CFS) = 7.56
PIPE TRAVEL TIME(MIN.) = 0.02 Tc(MIN.) = 7.36
LONGEST FLOWPATH FROM NODE 9.00 TO NODE 25.00 = 517.62 FEET.

FLOW PROCESS FROM NODE 26.00 TO NODE 27.00 IS CODE = 41

>>>>COMPUTE PIPE-FLOW TRAVEL TIME THRU SUBAREA<<<<<
>>>>USING USER-SPECIFIED PIPESIZE (EXISTING ELEMENT)<<<<<

=====

REPRESENTATIVE SLOPE = 0.0040
FLOW LENGTH(FEET) = 255.17 MANNING'S N = 0.010
DEPTH OF FLOW IN 18.0 INCH PIPE IS 13.3 INCHES
PIPE-FLOW VELOCITY(FEET/SEC.) = 5.39
GIVEN PIPE DIAMETER(INCH) = 18.00 NUMBER OF PIPES = 1
PIPE-FLOW(CFS) = 7.56
PIPE TRAVEL TIME(MIN.) = 0.79 Tc(MIN.) = 8.15
LONGEST FLOWPATH FROM NODE 9.00 TO NODE 27.00 = 772.79 FEET.

FLOW PROCESS FROM NODE 27.00 TO NODE 27.10 IS CODE = 41

>>>>COMPUTE PIPE-FLOW TRAVEL TIME THRU SUBAREA<<<<<
>>>>USING USER-SPECIFIED PIPESIZE (EXISTING ELEMENT)<<<<<

=====

REPRESENTATIVE SLOPE = 0.0040
FLOW LENGTH(FEET) = 279.97 MANNING'S N = 0.010
DEPTH OF FLOW IN 18.0 INCH PIPE IS 13.3 INCHES
PIPE-FLOW VELOCITY(FEET/SEC.) = 5.39
GIVEN PIPE DIAMETER(INCH) = 18.00 NUMBER OF PIPES = 1
PIPE-FLOW(CFS) = 7.56
PIPE TRAVEL TIME(MIN.) = 0.87 Tc(MIN.) = 9.02
LONGEST FLOWPATH FROM NODE 9.00 TO NODE 27.10 = 1052.76 FEET.

FLOW PROCESS FROM NODE 27.10 TO NODE 27.10 IS CODE = 10

>>>>MAIN-STREAM MEMORY COPIED ONTO MEMORY BANK # 1 <<<<<

=====

FLOW PROCESS FROM NODE 27.10 TO NODE 27.10 IS CODE = 13

>>>>CLEAR THE MAIN-STREAM MEMORY<<<<<

FLOW PROCESS FROM NODE 27.20 TO NODE 27.30 IS CODE = 21

>>>>RATIONAL METHOD INITIAL SUBAREA ANALYSIS<<<<<

=====

ASSUMED INITIAL SUBAREA UNIFORM
DEVELOPMENT IS SINGLE FAMILY (1/4 ACRE)
TC = $K * [(LENGTH**3)/(ELEVATION CHANGE)]**.2$
INITIAL SUBAREA FLOW-LENGTH(FEET) = 2313.53
UPSTREAM ELEVATION(FEET) = 910.75
DOWNSTREAM ELEVATION(FEET) = 881.40
ELEVATION DIFFERENCE(FEET) = 29.35
TC = $0.393 * [(2313.53**3)/(29.35)]**.2 = 20.845$
10 YEAR RAINFALL INTENSITY(INCH/HOUR) = 1.444
SINGLE-FAMILY(1/4 ACRE LOT) RUNOFF COEFFICIENT = .7681
SOIL CLASSIFICATION IS "C"
SUBAREA RUNOFF(CFS) = 14.65
TOTAL AREA(ACRES) = 13.21 TOTAL RUNOFF(CFS) = 14.65

FLOW PROCESS FROM NODE 27.30 TO NODE 27.40 IS CODE = 41

>>>>COMPUTE PIPE-FLOW TRAVEL TIME THRU SUBAREA<<<<<
>>>>USING USER-SPECIFIED PIPESIZE (EXISTING ELEMENT)<<<<<

=====

REPRESENTATIVE SLOPE = 0.0125
FLOW LENGTH(FEET) = 22.90 MANNING'S N = 0.013
DEPTH OF FLOW IN 24.0 INCH PIPE IS 13.3 INCHES
PIPE-FLOW VELOCITY(FEET/SEC.) = 8.18
GIVEN PIPE DIAMETER(INCH) = 24.00 NUMBER OF PIPES = 1
PIPE-FLOW(CFS) = 14.65
PIPE TRAVEL TIME(MIN.) = 0.05 Tc(MIN.) = 20.89
LONGEST FLOWPATH FROM NODE 27.20 TO NODE 27.40 = 2336.43 FEET.

FLOW PROCESS FROM NODE 27.40 TO NODE 27.50 IS CODE = 41

>>>>COMPUTE PIPE-FLOW TRAVEL TIME THRU SUBAREA<<<<<
>>>>USING USER-SPECIFIED PIPESIZE (EXISTING ELEMENT)<<<<<

=====

REPRESENTATIVE SLOPE = 0.0150
FLOW LENGTH(FEET) = 221.35 MANNING'S N = 0.013
DEPTH OF FLOW IN 24.0 INCH PIPE IS 12.6 INCHES
PIPE-FLOW VELOCITY(FEET/SEC.) = 8.77
GIVEN PIPE DIAMETER(INCH) = 24.00 NUMBER OF PIPES = 1
PIPE-FLOW(CFS) = 14.65
PIPE TRAVEL TIME(MIN.) = 0.42 Tc(MIN.) = 21.31
LONGEST FLOWPATH FROM NODE 27.20 TO NODE 27.50 = 2557.78 FEET.

FLOW PROCESS FROM NODE 27.50 TO NODE 27.10 IS CODE = 41

>>>>COMPUTE PIPE-FLOW TRAVEL TIME THRU SUBAREA<<<<<
>>>>USING USER-SPECIFIED PIPESIZE (EXISTING ELEMENT)<<<<<
=====

REPRESENTATIVE SLOPE = 0.0150
FLOW LENGTH(FEET) = 106.50 MANNING'S N = 0.013
DEPTH OF FLOW IN 24.0 INCH PIPE IS 12.6 INCHES
PIPE-FLOW VELOCITY(FEET/SEC.) = 8.77
GIVEN PIPE DIAMETER(INCH) = 24.00 NUMBER OF PIPES = 1
PIPE-FLOW(CFS) = 14.65
PIPE TRAVEL TIME(MIN.) = 0.20 Tc(MIN.) = 21.51
LONGEST FLOWPATH FROM NODE 27.20 TO NODE 27.10 = 2664.28 FEET.

FLOW PROCESS FROM NODE 27.10 TO NODE 27.10 IS CODE = 11

>>>>CONFLUENCE MEMORY BANK # 1 WITH THE MAIN-STREAM MEMORY<<<<<
=====

** MAIN STREAM CONFLUENCE DATA **

STREAM NUMBER	RUNOFF (CFS)	Tc (MIN.)	INTENSITY (INCH/HOUR)	AREA (ACRE)
1	14.65	21.51	1.419	13.21

LONGEST FLOWPATH FROM NODE 27.20 TO NODE 27.10 = 2664.28 FEET.

** MEMORY BANK # 1 CONFLUENCE DATA **

STREAM NUMBER	RUNOFF (CFS)	Tc (MIN.)	INTENSITY (INCH/HOUR)	AREA (ACRE)
1	6.73	6.94	2.642	3.38
2	7.12	7.24	2.580	3.38
3	7.31	7.45	2.540	3.38
4	7.33	7.47	2.537	3.38
5	7.42	7.62	2.509	3.38
6	7.47	7.68	2.498	3.38
7	7.53	7.99	2.445	3.38
8	7.56	9.00	2.290	3.38
9	7.56	9.02	2.288	3.38
10	5.31	16.19	1.659	3.38

LONGEST FLOWPATH FROM NODE 9.00 TO NODE 27.10 = 1052.76 FEET.

** PEAK FLOW RATE TABLE **

STREAM NUMBER	RUNOFF (CFS)	Tc (MIN.)	INTENSITY (INCH/HOUR)
1	11.45	6.94	2.642
2	12.05	7.24	2.580
3	12.39	7.45	2.540
4	12.42	7.47	2.537

5	12.61	7.62	2.509
6	12.70	7.68	2.498
7	12.97	7.99	2.445
8	13.69	9.00	2.290
9	13.70	9.02	2.288
10	16.33	16.19	1.659
11	19.34	21.51	1.419

COMPUTED CONFLUENCE ESTIMATES ARE AS FOLLOWS:

PEAK FLOW RATE(CFS) = 19.34 Tc(MIN.) = 21.51

TOTAL AREA(ACRES) = 16.6

FLOW PROCESS FROM NODE 27.10 TO NODE 27.10 IS CODE = 12

>>>>CLEAR MEMORY BANK # 1 <<<<<

FLOW PROCESS FROM NODE 27.10 TO NODE 28.00 IS CODE = 41

>>>>COMPUTE PIPE-FLOW TRAVEL TIME THRU SUBAREA<<<<<
>>>>USING USER-SPECIFIED PIPESIZE (EXISTING ELEMENT)<<<<<

=====

REPRESENTATIVE SLOPE = 0.0040
FLOW LENGTH(FEET) = 71.25 MANNING'S N = 0.013
DEPTH OF FLOW IN 36.0 INCH PIPE IS 17.4 INCHES
PIPE-FLOW VELOCITY(FEET/SEC.) = 5.73
GIVEN PIPE DIAMETER(INCH) = 36.00 NUMBER OF PIPES = 1
PIPE-FLOW(CFS) = 19.34
PIPE TRAVEL TIME(MIN.) = 0.21 Tc(MIN.) = 21.72
LONGEST FLOWPATH FROM NODE 27.20 TO NODE 28.00 = 2735.53 FEET.

FLOW PROCESS FROM NODE 28.00 TO NODE 28.00 IS CODE = 10

>>>>MAIN-STREAM MEMORY COPIED ONTO MEMORY BANK # 1 <<<<<

FLOW PROCESS FROM NODE 28.00 TO NODE 28.00 IS CODE = 13

>>>>CLEAR THE MAIN-STREAM MEMORY<<<<<

FLOW PROCESS FROM NODE 29.00 TO NODE 30.00 IS CODE = 21

>>>>RATIONAL METHOD INITIAL SUBAREA ANALYSIS<<<<<

ASSUMED INITIAL SUBAREA UNIFORM
DEVELOPMENT IS APARTMENT

TC = $K * [(LENGTH^{**3}) / (ELEVATION CHANGE)]^{**0.2}$
INITIAL SUBAREA FLOW-LENGTH(FEET) = 61.88
UPSTREAM ELEVATION(FEET) = 882.80
DOWNSTREAM ELEVATION(FEET) = 882.10
ELEVATION DIFFERENCE(FEET) = 0.70
TC = $0.323 * [(61.88^{**3}) / (0.70)]^{**0.2} = 4.118$
COMPUTED TIME OF CONCENTRATION INCREASED TO 5 MIN.
10 YEAR RAINFALL INTENSITY(INCH/HOUR) = 3.163
APARTMENT DEVELOPMENT RUNOFF COEFFICIENT = .8713
SOIL CLASSIFICATION IS "C"
SUBAREA RUNOFF(CFS) = 0.45
TOTAL AREA(ACRES) = 0.16 TOTAL RUNOFF(CFS) = 0.45

FLOW PROCESS FROM NODE 30.00 TO NODE 31.00 IS CODE = 41

>>>>COMPUTE PIPE-FLOW TRAVEL TIME THRU SUBAREA<<<<<
>>>>USING USER-SPECIFIED PIPESIZE (EXISTING ELEMENT)<<<<<

=====

REPRESENTATIVE SLOPE = 0.0100
FLOW LENGTH(FEET) = 55.57 MANNING'S N = 0.009
ASSUME FULL-FLOWING PIPELINE
PIPE-FLOW VELOCITY(FEET/SEC.) = 5.18
PIPE FLOW VELOCITY = (TOTAL FLOW)/(PIPE CROSS SECTION AREA)
GIVEN PIPE DIAMETER(INCH) = 4.00 NUMBER OF PIPES = 1
PIPE-FLOW(CFS) = 0.45
PIPE TRAVEL TIME(MIN.) = 0.18 Tc(MIN.) = 5.18
LONGEST FLOWPATH FROM NODE 29.00 TO NODE 31.00 = 117.45 FEET.

FLOW PROCESS FROM NODE 31.00 TO NODE 32.00 IS CODE = 41

>>>>COMPUTE PIPE-FLOW TRAVEL TIME THRU SUBAREA<<<<<
>>>>USING USER-SPECIFIED PIPESIZE (EXISTING ELEMENT)<<<<<

=====

REPRESENTATIVE SLOPE = 0.0100
FLOW LENGTH(FEET) = 89.09 MANNING'S N = 0.009
DEPTH OF FLOW IN 6.0 INCH PIPE IS 3.2 INCHES
PIPE-FLOW VELOCITY(FEET/SEC.) = 4.16
GIVEN PIPE DIAMETER(INCH) = 6.00 NUMBER OF PIPES = 1
PIPE-FLOW(CFS) = 0.45
PIPE TRAVEL TIME(MIN.) = 0.36 Tc(MIN.) = 5.54
LONGEST FLOWPATH FROM NODE 29.00 TO NODE 32.00 = 206.54 FEET.

FLOW PROCESS FROM NODE 32.00 TO NODE 33.00 IS CODE = 41

>>>>COMPUTE PIPE-FLOW TRAVEL TIME THRU SUBAREA<<<<<

>>>>USING USER-SPECIFIED PIPESIZE (EXISTING ELEMENT)<<<<<

=====

REPRESENTATIVE SLOPE = 0.0100
FLOW LENGTH(FEET) = 23.50 MANNING'S N = 0.009
DEPTH OF FLOW IN 8.0 INCH PIPE IS 2.8 INCHES
PIPE-FLOW VELOCITY(FEET/SEC.) = 4.09
GIVEN PIPE DIAMETER(INCH) = 8.00 NUMBER OF PIPES = 1
PIPE-FLOW(CFS) = 0.45
PIPE TRAVEL TIME(MIN.) = 0.10 Tc(MIN.) = 5.63
LONGEST FLOWPATH FROM NODE 29.00 TO NODE 33.00 = 230.04 FEET.

FLOW PROCESS FROM NODE 33.00 TO NODE 33.00 IS CODE = 10

>>>>MAIN-STREAM MEMORY COPIED ONTO MEMORY BANK # 3 <<<<<

FLOW PROCESS FROM NODE 33.00 TO NODE 33.00 IS CODE = 13

>>>>CLEAR THE MAIN-STREAM MEMORY<<<<<

FLOW PROCESS FROM NODE 34.00 TO NODE 35.00 IS CODE = 21

>>>>RATIONAL METHOD INITIAL SUBAREA ANALYSIS<<<<<

=====

ASSUMED INITIAL SUBAREA UNIFORM
DEVELOPMENT IS APARTMENT
 $TC = K * [(LENGTH^{**3}) / (ELEVATION CHANGE)]^{**0.2}$
INITIAL SUBAREA FLOW-LENGTH(FEET) = 65.92
UPSTREAM ELEVATION(FEET) = 15.00
DOWNSTREAM ELEVATION(FEET) = 13.00
ELEVATION DIFFERENCE(FEET) = 2.00
 $TC = 0.323 * [(65.92^{**3}) / (2.00)]^{**0.2} = 3.467$
COMPUTED TIME OF CONCENTRATION INCREASED TO 5 MIN.
10 YEAR RAINFALL INTENSITY(INCH/HOUR) = 3.163
APARTMENT DEVELOPMENT RUNOFF COEFFICIENT = .8713
SOIL CLASSIFICATION IS "C"
SUBAREA RUNOFF(CFS) = 0.26
TOTAL AREA(ACRES) = 0.09 TOTAL RUNOFF(CFS) = 0.26

FLOW PROCESS FROM NODE 35.00 TO NODE 33.00 IS CODE = 41

>>>>COMPUTE PIPE-FLOW TRAVEL TIME THRU SUBAREA<<<<<
>>>>USING USER-SPECIFIED PIPESIZE (EXISTING ELEMENT)<<<<<

=====

REPRESENTATIVE SLOPE = 0.0100

FLOW LENGTH(FEET) = 2.00 MANNING'S N = 0.009
 DEPTH OF FLOW IN 4.0 INCH PIPE IS 3.2 INCHES
 PIPE-FLOW VELOCITY(FEET/SEC.) = 3.46
 GIVEN PIPE DIAMETER(INCH) = 4.00 NUMBER OF PIPES = 1
 PIPE-FLOW(CFS) = 0.26
 PIPE TRAVEL TIME(MIN.) = 0.01 Tc(MIN.) = 5.01
 LONGEST FLOWPATH FROM NODE 34.00 TO NODE 33.00 = 67.92 FEET.

 FLOW PROCESS FROM NODE 33.00 TO NODE 33.00 IS CODE = 11

 >>>>CONFLUENCE MEMORY BANK # 3 WITH THE MAIN-STREAM MEMORY<<<<<

=====
 ** MAIN STREAM CONFLUENCE DATA **

STREAM NUMBER	RUNOFF (CFS)	Tc (MIN.)	INTENSITY (INCH/HOUR)	AREA (ACRE)
1	0.26	5.01	3.159	0.09

LONGEST FLOWPATH FROM NODE 34.00 TO NODE 33.00 = 67.92 FEET.

** MEMORY BANK # 3 CONFLUENCE DATA **

STREAM NUMBER	RUNOFF (CFS)	Tc (MIN.)	INTENSITY (INCH/HOUR)	AREA (ACRE)
1	0.45	5.63	2.963	0.16

LONGEST FLOWPATH FROM NODE 29.00 TO NODE 33.00 = 230.04 FEET.

** PEAK FLOW RATE TABLE **

STREAM NUMBER	RUNOFF (CFS)	Tc (MIN.)	INTENSITY (INCH/HOUR)
1	0.66	5.01	3.159
2	0.69	5.63	2.963

COMPUTED CONFLUENCE ESTIMATES ARE AS FOLLOWS:

PEAK FLOW RATE(CFS) = 0.69 Tc(MIN.) = 5.63
 TOTAL AREA(ACRES) = 0.3

 FLOW PROCESS FROM NODE 33.00 TO NODE 33.00 IS CODE = 12

 >>>>CLEAR MEMORY BANK # 3 <<<<<

 FLOW PROCESS FROM NODE 33.00 TO NODE 36.00 IS CODE = 41

 >>>>COMPUTE PIPE-FLOW TRAVEL TIME THRU SUBAREA<<<<<
 >>>>USING USER-SPECIFIED PIPESIZE (EXISTING ELEMENT)<<<<<

=====
 REPRESENTATIVE SLOPE = 0.0100
 FLOW LENGTH(FEET) = 48.57 MANNING'S N = 0.009

DEPTH OF FLOW IN 8.0 INCH PIPE IS 3.6 INCHES
PIPE-FLOW VELOCITY(FEET/SEC.) = 4.62
GIVEN PIPE DIAMETER(INCH) = 8.00 NUMBER OF PIPES = 1
PIPE-FLOW(CFS) = 0.69
PIPE TRAVEL TIME(MIN.) = 0.18 Tc(MIN.) = 5.81
LONGEST FLOWPATH FROM NODE 29.00 TO NODE 36.00 = 278.61 FEET.

FLOW PROCESS FROM NODE 36.00 TO NODE 36.00 IS CODE = 10

>>>>MAIN-STREAM MEMORY COPIED ONTO MEMORY BANK # 3 <<<<<

FLOW PROCESS FROM NODE 34.00 TO NODE 34.00 IS CODE = 13

>>>>CLEAR THE MAIN-STREAM MEMORY<<<<<

FLOW PROCESS FROM NODE 37.00 TO NODE 38.00 IS CODE = 21

>>>>RATIONAL METHOD INITIAL SUBAREA ANALYSIS<<<<<

=====

ASSUMED INITIAL SUBAREA UNIFORM
DEVELOPMENT IS: UNDEVELOPED WITH GOOD COVER
TC = $K * [(LENGTH^{**3}) / (ELEVATION CHANGE)]^{** .2}$
INITIAL SUBAREA FLOW-LENGTH(FEET) = 47.00
UPSTREAM ELEVATION(FEET) = 879.59
DOWNSTREAM ELEVATION(FEET) = 878.75
ELEVATION DIFFERENCE(FEET) = 0.84
TC = $0.937 * [(47.00^{**3}) / (0.84)]^{** .2} = 9.780$
10 YEAR RAINFALL INTENSITY(INCH/HOUR) = 2.188
UNDEVELOPED WATERSHED RUNOFF COEFFICIENT = .7066
SOIL CLASSIFICATION IS "C"
SUBAREA RUNOFF(CFS) = 0.14
TOTAL AREA(ACRES) = 0.09 TOTAL RUNOFF(CFS) = 0.14

FLOW PROCESS FROM NODE 38.00 TO NODE 36.00 IS CODE = 41

>>>>COMPUTE PIPE-FLOW TRAVEL TIME THRU SUBAREA<<<<<
>>>>USING USER-SPECIFIED PIPESIZE (EXISTING ELEMENT)<<<<<

=====

REPRESENTATIVE SLOPE = 0.0100
FLOW LENGTH(FEET) = 14.50 MANNING'S N = 0.009
DEPTH OF FLOW IN 10.0 INCH PIPE IS 1.4 INCHES
PIPE-FLOW VELOCITY(FEET/SEC.) = 2.88
GIVEN PIPE DIAMETER(INCH) = 10.00 NUMBER OF PIPES = 1
PIPE-FLOW(CFS) = 0.14

PIPE TRAVEL TIME(MIN.) = 0.08 Tc(MIN.) = 9.86
LONGEST FLOWPATH FROM NODE 37.00 TO NODE 36.00 = 61.50 FEET.

FLOW PROCESS FROM NODE 36.00 TO NODE 36.00 IS CODE = 11

>>>>>CONFLUENCE MEMORY BANK # 3 WITH THE MAIN-STREAM MEMORY<<<<<<

=====
** MAIN STREAM CONFLUENCE DATA **

STREAM NUMBER	RUNOFF (CFS)	Tc (MIN.)	INTENSITY (INCH/HOUR)	AREA (ACRE)
1	0.14	9.86	2.178	0.09

LONGEST FLOWPATH FROM NODE 37.00 TO NODE 36.00 = 61.50 FEET.

** MEMORY BANK # 3 CONFLUENCE DATA **

STREAM NUMBER	RUNOFF (CFS)	Tc (MIN.)	INTENSITY (INCH/HOUR)	AREA (ACRE)
1	0.66	5.19	3.100	0.26
2	0.69	5.81	2.913	0.26

LONGEST FLOWPATH FROM NODE 29.00 TO NODE 36.00 = 278.61 FEET.

** PEAK FLOW RATE TABLE **

STREAM NUMBER	RUNOFF (CFS)	Tc (MIN.)	INTENSITY (INCH/HOUR)
1	0.73	5.19	3.100
2	0.77	5.81	2.913
3	0.66	9.86	2.178

COMPUTED CONFLUENCE ESTIMATES ARE AS FOLLOWS:

PEAK FLOW RATE(CFS) = 0.77 Tc(MIN.) = 5.81
TOTAL AREA(ACRES) = 0.3

FLOW PROCESS FROM NODE 36.00 TO NODE 39.00 IS CODE = 41

>>>>>COMPUTE PIPE-FLOW TRAVEL TIME THRU SUBAREA<<<<<<

>>>>>USING USER-SPECIFIED PIPESIZE (EXISTING ELEMENT)<<<<<<

=====
REPRESENTATIVE SLOPE = 0.0100
FLOW LENGTH(FEET) = 52.84 MANNING'S N = 0.009
DEPTH OF FLOW IN 10.0 INCH PIPE IS 3.4 INCHES
PIPE-FLOW VELOCITY(FEET/SEC.) = 4.72
GIVEN PIPE DIAMETER(INCH) = 10.00 NUMBER OF PIPES = 1
PIPE-FLOW(CFS) = 0.77
PIPE TRAVEL TIME(MIN.) = 0.19 Tc(MIN.) = 5.99
LONGEST FLOWPATH FROM NODE 29.00 TO NODE 39.00 = 331.45 FEET.

FLOW PROCESS FROM NODE 39.00 TO NODE 39.00 IS CODE = 10

>>>>MAIN-STREAM MEMORY COPIED ONTO MEMORY BANK # 3 <<<<<

=====

***MEMORY BANK # 3 IS FULL. THEREFORE, MAIN-STREAM MEMORY
DATA CAN NOT BE COPIED ONTO IT - PROCESS IGNORED.***

FLOW PROCESS FROM NODE 39.00 TO NODE 39.00 IS CODE = 13

>>>>CLEAR THE MAIN-STREAM MEMORY<<<<<

FLOW PROCESS FROM NODE 40.00 TO NODE 41.00 IS CODE = 21

>>>>RATIONAL METHOD INITIAL SUBAREA ANALYSIS<<<<<

=====

ASSUMED INITIAL SUBAREA UNIFORM
DEVELOPMENT IS APARTMENT

$TC = K * [(LENGTH^{**3}) / (ELEVATION CHANGE)]^{** .2}$
INITIAL SUBAREA FLOW-LENGTH(FEET) = 74.92
UPSTREAM ELEVATION(FEET) = 15.00
DOWNSTREAM ELEVATION(FEET) = 13.00
ELEVATION DIFFERENCE(FEET) = 2.00
 $TC = 0.323 * [(74.92^{**3}) / (2.00)]^{** .2} = 3.744$
COMPUTED TIME OF CONCENTRATION INCREASED TO 5 MIN.
10 YEAR RAINFALL INTENSITY(INCH/HOUR) = 3.163
APARTMENT DEVELOPMENT RUNOFF COEFFICIENT = .8713
SOIL CLASSIFICATION IS "C"
SUBAREA RUNOFF(CFS) = 1.11
TOTAL AREA(ACRES) = 0.40 TOTAL RUNOFF(CFS) = 1.11

FLOW PROCESS FROM NODE 41.00 TO NODE 39.00 IS CODE = 41

>>>>COMPUTE PIPE-FLOW TRAVEL TIME THRU SUBAREA<<<<<
>>>>USING USER-SPECIFIED PIPESIZE (EXISTING ELEMENT)<<<<<

=====

REPRESENTATIVE SLOPE = 0.0100
FLOW LENGTH(FEET) = 7.00 MANNING'S N = 0.009
ASSUME FULL-FLOWING PIPELINE
PIPE-FLOW VELOCITY(FEET/SEC.) = 12.76
PIPE FLOW VELOCITY = (TOTAL FLOW)/(PIPE CROSS SECTION AREA)
GIVEN PIPE DIAMETER(INCH) = 4.00 NUMBER OF PIPES = 1
PIPE-FLOW(CFS) = 1.11
PIPE TRAVEL TIME(MIN.) = 0.01 Tc(MIN.) = 5.01
LONGEST FLOWPATH FROM NODE 40.00 TO NODE 39.00 = 81.92 FEET.

FLOW PROCESS FROM NODE 39.00 TO NODE 39.00 IS CODE = 11

>>>>>CONFLUENCE MEMORY BANK # 3 WITH THE MAIN-STREAM MEMORY<<<<<<
=====

** MAIN STREAM CONFLUENCE DATA **

STREAM NUMBER	RUNOFF (CFS)	Tc (MIN.)	INTENSITY (INCH/HOUR)	AREA (ACRE)		
1	1.11	5.01	3.159	0.40		
LONGEST FLOWPATH FROM NODE			40.00 TO NODE	39.00 =		81.92 FEET.

** MEMORY BANK # 3 CONFLUENCE DATA **

STREAM NUMBER	RUNOFF (CFS)	Tc (MIN.)	INTENSITY (INCH/HOUR)	AREA (ACRE)		
1	0.66	5.19	3.100	0.26		
2	0.69	5.81	2.913	0.26		
LONGEST FLOWPATH FROM NODE			29.00 TO NODE	39.00 =		278.61 FEET.

** PEAK FLOW RATE TABLE **

STREAM NUMBER	RUNOFF (CFS)	Tc (MIN.)	INTENSITY (INCH/HOUR)
1	1.75	5.01	3.159
2	1.75	5.19	3.100
3	1.72	5.81	2.913

COMPUTED CONFLUENCE ESTIMATES ARE AS FOLLOWS:

PEAK FLOW RATE(CFS) = 1.75 Tc(MIN.) = 5.19
TOTAL AREA(ACRES) = 0.7

FLOW PROCESS FROM NODE 39.00 TO NODE 39.00 IS CODE = 12

>>>>>CLEAR MEMORY BANK # 3 <<<<<<
=====

FLOW PROCESS FROM NODE 39.00 TO NODE 42.00 IS CODE = 41

>>>>>COMPUTE PIPE-FLOW TRAVEL TIME THRU SUBAREA<<<<<<
>>>>>USING USER-SPECIFIED PIPESIZE (EXISTING ELEMENT)<<<<<<
=====

REPRESENTATIVE SLOPE = 0.0100
FLOW LENGTH(FEET) = 52.87 MANNING'S N = 0.009
DEPTH OF FLOW IN 10.0 INCH PIPE IS 5.4 INCHES
PIPE-FLOW VELOCITY(FEET/SEC.) = 5.83
GIVEN PIPE DIAMETER(INCH) = 10.00 NUMBER OF PIPES = 1
PIPE-FLOW(CFS) = 1.75
PIPE TRAVEL TIME(MIN.) = 0.15 Tc(MIN.) = 5.34
LONGEST FLOWPATH FROM NODE 29.00 TO NODE 42.00 = 331.48 FEET.

FLOW PROCESS FROM NODE 42.00 TO NODE 43.00 IS CODE = 41

>>>>COMPUTE PIPE-FLOW TRAVEL TIME THRU SUBAREA<<<<<
>>>>USING USER-SPECIFIED PIPESIZE (EXISTING ELEMENT)<<<<<

=====

REPRESENTATIVE SLOPE = 0.0100
FLOW LENGTH(FEET) = 91.61 MANNING'S N = 0.010
DEPTH OF FLOW IN 12.0 INCH PIPE IS 5.2 INCHES
PIPE-FLOW VELOCITY(FEET/SEC.) = 5.38
GIVEN PIPE DIAMETER(INCH) = 12.00 NUMBER OF PIPES = 1
PIPE-FLOW(CFS) = 1.75
PIPE TRAVEL TIME(MIN.) = 0.28 Tc(MIN.) = 5.62
LONGEST FLOWPATH FROM NODE 29.00 TO NODE 43.00 = 423.09 FEET.

FLOW PROCESS FROM NODE 43.00 TO NODE 43.00 IS CODE = 10

>>>>MAIN-STREAM MEMORY COPIED ONTO MEMORY BANK # 3 <<<<<

FLOW PROCESS FROM NODE 43.00 TO NODE 43.00 IS CODE = 13

>>>>CLEAR THE MAIN-STREAM MEMORY<<<<<

FLOW PROCESS FROM NODE 44.00 TO NODE 45.00 IS CODE = 21

>>>>RATIONAL METHOD INITIAL SUBAREA ANALYSIS<<<<<

=====

ASSUMED INITIAL SUBAREA UNIFORM
DEVELOPMENT IS APARTMENT
 $TC = K * [(LENGTH^{**3}) / (ELEVATION CHANGE)]^{**0.2}$
INITIAL SUBAREA FLOW-LENGTH(FEET) = 47.00
UPSTREAM ELEVATION(FEET) = 15.00
DOWNSTREAM ELEVATION(FEET) = 13.00
ELEVATION DIFFERENCE(FEET) = 2.00
 $TC = 0.323 * [(47.00^{**3}) / (2.00)]^{**0.2} = 2.830$
COMPUTED TIME OF CONCENTRATION INCREASED TO 5 MIN.
10 YEAR RAINFALL INTENSITY(INCH/HOUR) = 3.163
APARTMENT DEVELOPMENT RUNOFF COEFFICIENT = .8713
SOIL CLASSIFICATION IS "C"
SUBAREA RUNOFF(CFS) = 0.97
TOTAL AREA(ACRES) = 0.35 TOTAL RUNOFF(CFS) = 0.97

FLOW PROCESS FROM NODE 45.00 TO NODE 46.00 IS CODE = 41

>>>>COMPUTE PIPE-FLOW TRAVEL TIME THRU SUBAREA<<<<<

>>>>USING USER-SPECIFIED PIPESIZE (EXISTING ELEMENT)<<<<<

=====

REPRESENTATIVE SLOPE = 0.0100
FLOW LENGTH(FEET) = 32.65 MANNING'S N = 0.009
ASSUME FULL-FLOWING PIPELINE
PIPE-FLOW VELOCITY(FEET/SEC.) = 4.95
PIPE FLOW VELOCITY = (TOTAL FLOW)/(PIPE CROSS SECTION AREA)
GIVEN PIPE DIAMETER(INCH) = 6.00 NUMBER OF PIPES = 1
PIPE-FLOW(CFS) = 0.97
PIPE TRAVEL TIME(MIN.) = 0.11 Tc(MIN.) = 5.11
LONGEST FLOWPATH FROM NODE 44.00 TO NODE 46.00 = 79.65 FEET.

FLOW PROCESS FROM NODE 46.00 TO NODE 47.00 IS CODE = 41

>>>>COMPUTE PIPE-FLOW TRAVEL TIME THRU SUBAREA<<<<<
>>>>USING USER-SPECIFIED PIPESIZE (EXISTING ELEMENT)<<<<<

=====

REPRESENTATIVE SLOPE = 0.0100
FLOW LENGTH(FEET) = 231.00 MANNING'S N = 0.009
DEPTH OF FLOW IN 8.0 INCH PIPE IS 4.3 INCHES
PIPE-FLOW VELOCITY(FEET/SEC.) = 5.04
GIVEN PIPE DIAMETER(INCH) = 8.00 NUMBER OF PIPES = 1
PIPE-FLOW(CFS) = 0.97
PIPE TRAVEL TIME(MIN.) = 0.76 Tc(MIN.) = 5.87
LONGEST FLOWPATH FROM NODE 44.00 TO NODE 47.00 = 310.65 FEET.

FLOW PROCESS FROM NODE 47.00 TO NODE 47.00 IS CODE = 81

>>>>ADDITION OF SUBAREA TO MAINLINE PEAK FLOW<<<<<

=====

10 YEAR RAINFALL INTENSITY(INCH/HOUR) = 2.895
APARTMENT DEVELOPMENT RUNOFF COEFFICIENT = .8691
SOIL CLASSIFICATION IS "C"
SUBAREA AREA(ACRES) = 0.22 SUBAREA RUNOFF(CFS) = 0.56
TOTAL AREA(ACRES) = 0.6 TOTAL RUNOFF(CFS) = 1.53
TC(MIN.) = 5.87

FLOW PROCESS FROM NODE 47.00 TO NODE 48.00 IS CODE = 41

>>>>COMPUTE PIPE-FLOW TRAVEL TIME THRU SUBAREA<<<<<
>>>>USING USER-SPECIFIED PIPESIZE (EXISTING ELEMENT)<<<<<

=====

REPRESENTATIVE SLOPE = 0.0100
FLOW LENGTH(FEET) = 40.21 MANNING'S N = 0.009
DEPTH OF FLOW IN 8.0 INCH PIPE IS 5.9 INCHES
PIPE-FLOW VELOCITY(FEET/SEC.) = 5.51
GIVEN PIPE DIAMETER(INCH) = 8.00 NUMBER OF PIPES = 1

PIPE-FLOW(CFS) = 1.53
PIPE TRAVEL TIME(MIN.) = 0.12 Tc(MIN.) = 6.00
LONGEST FLOWPATH FROM NODE 44.00 TO NODE 48.00 = 350.86 FEET.

FLOW PROCESS FROM NODE 48.00 TO NODE 48.00 IS CODE = 81

>>>>ADDITION OF SUBAREA TO MAINLINE PEAK FLOW<<<<<

=====

10 YEAR RAINFALL INTENSITY(INCH/HOUR) = 2.863
APARTMENT DEVELOPMENT RUNOFF COEFFICIENT = .8689
SOIL CLASSIFICATION IS "C"
SUBAREA AREA(ACRES) = 0.29 SUBAREA RUNOFF(CFS) = 0.72
TOTAL AREA(ACRES) = 0.9 TOTAL RUNOFF(CFS) = 2.25
TC(MIN.) = 6.00

FLOW PROCESS FROM NODE 48.00 TO NODE 43.00 IS CODE = 41

>>>>COMPUTE PIPE-FLOW TRAVEL TIME THRU SUBAREA<<<<<
>>>>USING USER-SPECIFIED PIPESIZE (EXISTING ELEMENT)<<<<<

=====

REPRESENTATIVE SLOPE = 0.0100
FLOW LENGTH(FEET) = 98.04 MANNING'S N = 0.009
ASSUME FULL-FLOWING PIPELINE
PIPE-FLOW VELOCITY(FEET/SEC.) = 6.45
PIPE FLOW VELOCITY = (TOTAL FLOW)/(PIPE CROSS SECTION AREA)
GIVEN PIPE DIAMETER(INCH) = 8.00 NUMBER OF PIPES = 1
PIPE-FLOW(CFS) = 2.25
PIPE TRAVEL TIME(MIN.) = 0.25 Tc(MIN.) = 6.25
LONGEST FLOWPATH FROM NODE 44.00 TO NODE 43.00 = 448.90 FEET.

FLOW PROCESS FROM NODE 43.00 TO NODE 43.00 IS CODE = 11

>>>>CONFLUENCE MEMORY BANK # 3 WITH THE MAIN-STREAM MEMORY<<<<<

=====

** MAIN STREAM CONFLUENCE DATA **

STREAM NUMBER	RUNOFF (CFS)	Tc (MIN.)	INTENSITY (INCH/HOUR)	AREA (ACRE)
1	2.25	6.25	2.798	0.86

LONGEST FLOWPATH FROM NODE 44.00 TO NODE 43.00 = 448.90 FEET.

** MEMORY BANK # 3 CONFLUENCE DATA **

STREAM NUMBER	RUNOFF (CFS)	Tc (MIN.)	INTENSITY (INCH/HOUR)	AREA (ACRE)
1	1.75	5.44	3.018	0.66
2	1.75	5.62	2.966	0.66
3	1.72	6.24	2.800	0.66

LONGEST FLOWPATH FROM NODE 29.00 TO NODE 43.00 = 423.09 FEET.

** PEAK FLOW RATE TABLE **

STREAM NUMBER	RUNOFF (CFS)	Tc (MIN.)	INTENSITY (INCH/HOUR)
1	3.71	5.44	3.018
2	3.77	5.62	2.966
3	3.97	6.24	2.800
4	3.97	6.25	2.798

COMPUTED CONFLUENCE ESTIMATES ARE AS FOLLOWS:

PEAK FLOW RATE(CFS) = 3.97 Tc(MIN.) = 6.25
TOTAL AREA(ACRES) = 1.5

FLOW PROCESS FROM NODE 43.00 TO NODE 43.00 IS CODE = 12

>>>>CLEAR MEMORY BANK # 3 <<<<<

FLOW PROCESS FROM NODE 43.00 TO NODE 49.00 IS CODE = 41

>>>>COMPUTE PIPE-FLOW TRAVEL TIME THRU SUBAREA<<<<<

>>>>USING USER-SPECIFIED PIPESIZE (EXISTING ELEMENT)<<<<<

REPRESENTATIVE SLOPE = 0.0100

FLOW LENGTH(FEET) = 33.92 MANNING'S N = 0.010

DEPTH OF FLOW IN 12.0 INCH PIPE IS 8.7 INCHES

PIPE-FLOW VELOCITY(FEET/SEC.) = 6.48

GIVEN PIPE DIAMETER(INCH) = 12.00 NUMBER OF PIPES = 1

PIPE-FLOW(CFS) = 3.97

PIPE TRAVEL TIME(MIN.) = 0.09 Tc(MIN.) = 6.34

LONGEST FLOWPATH FROM NODE 44.00 TO NODE 49.00 = 482.82 FEET.

FLOW PROCESS FROM NODE 49.00 TO NODE 49.00 IS CODE = 10

>>>>MAIN-STREAM MEMORY COPIED ONTO MEMORY BANK # 2 <<<<<

FLOW PROCESS FROM NODE 49.00 TO NODE 49.00 IS CODE = 13

>>>>CLEAR THE MAIN-STREAM MEMORY<<<<<

FLOW PROCESS FROM NODE 50.00 TO NODE 51.00 IS CODE = 21

>>>>RATIONAL METHOD INITIAL SUBAREA ANALYSIS<<<<<

=====

ASSUMED INITIAL SUBAREA UNIFORM
DEVELOPMENT IS APARTMENT

TC = $K * [(LENGTH^{**3}) / (ELEVATION CHANGE)]^{**0.2}$
 INITIAL SUBAREA FLOW-LENGTH(FEET) = 97.11
 UPSTREAM ELEVATION(FEET) = 878.85
 DOWNSTREAM ELEVATION(FEET) = 877.75
 ELEVATION DIFFERENCE(FEET) = 1.10
 TC = $0.323 * [(97.11^{**3}) / (1.10)]^{**0.2} = 4.930$
 COMPUTED TIME OF CONCENTRATION INCREASED TO 5 MIN.
 10 YEAR RAINFALL INTENSITY(INCH/HOUR) = 3.163
 APARTMENT DEVELOPMENT RUNOFF COEFFICIENT = .8713
 SOIL CLASSIFICATION IS "C"
 SUBAREA RUNOFF(CFS) = 0.93
 TOTAL AREA(ACRES) = 0.34 TOTAL RUNOFF(CFS) = 0.93

FLOW PROCESS FROM NODE 51.00 TO NODE 51.00 IS CODE = 11

>>>>CONFLUENCE MEMORY BANK # 2 WITH THE MAIN-STREAM MEMORY<<<<<

=====

** MAIN STREAM CONFLUENCE DATA **

STREAM NUMBER	RUNOFF (CFS)	Tc (MIN.)	INTENSITY (INCH/HOUR)	AREA (ACRE)
1	0.93	5.00	3.163	0.34

LONGEST FLOWPATH FROM NODE 50.00 TO NODE 51.00 = 97.11 FEET.

** MEMORY BANK # 2 CONFLUENCE DATA **

STREAM NUMBER	RUNOFF (CFS)	Tc (MIN.)	INTENSITY (INCH/HOUR)	AREA (ACRE)
1	3.71	5.53	2.992	1.52
2	3.77	5.71	2.940	1.52
3	3.97	6.33	2.778	1.52
4	3.97	6.34	2.777	1.52

LONGEST FLOWPATH FROM NODE 44.00 TO NODE 51.00 = 482.82 FEET.

** PEAK FLOW RATE TABLE **

STREAM NUMBER	RUNOFF (CFS)	Tc (MIN.)	INTENSITY (INCH/HOUR)
1	4.28	5.00	3.163
2	4.59	5.53	2.992
3	4.64	5.71	2.940
4	4.78	6.33	2.778
5	4.78	6.34	2.777

COMPUTED CONFLUENCE ESTIMATES ARE AS FOLLOWS:

PEAK FLOW RATE(CFS) = 4.78 Tc(MIN.) = 6.34
 TOTAL AREA(ACRES) = 1.9

FLOW PROCESS FROM NODE 51.00 TO NODE 51.00 IS CODE = 12

>>>>CLEAR MEMORY BANK # 2 <<<<<

FLOW PROCESS FROM NODE 51.00 TO NODE 52.00 IS CODE = 41

>>>>COMPUTE PIPE-FLOW TRAVEL TIME THRU SUBAREA<<<<<
>>>>USING USER-SPECIFIED PIPESIZE (EXISTING ELEMENT)<<<<<

REPRESENTATIVE SLOPE = 0.0100
FLOW LENGTH(FEET) = 51.05 MANNING'S N = 0.010
DEPTH OF FLOW IN 15.0 INCH PIPE IS 8.2 INCHES
PIPE-FLOW VELOCITY(FEET/SEC.) = 6.93
GIVEN PIPE DIAMETER(INCH) = 15.00 NUMBER OF PIPES = 1
PIPE-FLOW(CFS) = 4.78
PIPE TRAVEL TIME(MIN.) = 0.12 Tc(MIN.) = 6.46
LONGEST FLOWPATH FROM NODE 44.00 TO NODE 52.00 = 533.87 FEET.

FLOW PROCESS FROM NODE 52.00 TO NODE 52.00 IS CODE = 10

>>>>MAIN-STREAM MEMORY COPIED ONTO MEMORY BANK # 2 <<<<<

FLOW PROCESS FROM NODE 52.00 TO NODE 52.00 IS CODE = 13

>>>>CLEAR THE MAIN-STREAM MEMORY<<<<<

FLOW PROCESS FROM NODE 53.00 TO NODE 54.00 IS CODE = 21

>>>>RATIONAL METHOD INITIAL SUBAREA ANALYSIS<<<<<

ASSUMED INITIAL SUBAREA UNIFORM
DEVELOPMENT IS APARTMENT
 $TC = K * [(LENGTH^{**3}) / (ELEVATION CHANGE)]^{** .2}$
INITIAL SUBAREA FLOW-LENGTH(FEET) = 96.84
UPSTREAM ELEVATION(FEET) = 878.85
DOWNSTREAM ELEVATION(FEET) = 877.60
ELEVATION DIFFERENCE(FEET) = 1.25
 $TC = 0.323 * [(96.84^{**3}) / (1.25)]^{** .2} = 4.798$
COMPUTED TIME OF CONCENTRATION INCREASED TO 5 MIN.
10 YEAR RAINFALL INTENSITY(INCH/HOUR) = 3.163
APARTMENT DEVELOPMENT RUNOFF COEFFICIENT = .8713

SOIL CLASSIFICATION IS "C"
SUBAREA RUNOFF(CFS) = 0.85
TOTAL AREA(ACRES) = 0.31 TOTAL RUNOFF(CFS) = 0.85

FLOW PROCESS FROM NODE 54.00 TO NODE 54.00 IS CODE = 10

>>>>MAIN-STREAM MEMORY COPIED ONTO MEMORY BANK # 3 <<<<<

FLOW PROCESS FROM NODE 54.00 TO NODE 54.00 IS CODE = 13

>>>>CLEAR THE MAIN-STREAM MEMORY<<<<<

FLOW PROCESS FROM NODE 55.00 TO NODE 56.00 IS CODE = 21

>>>>RATIONAL METHOD INITIAL SUBAREA ANALYSIS<<<<<

ASSUMED INITIAL SUBAREA UNIFORM
DEVELOPMENT IS APARTMENT
TC = $K * [(LENGTH^{**3}) / (ELEVATION CHANGE)]^{** .2}$
INITIAL SUBAREA FLOW-LENGTH(FEET) = 217.19
UPSTREAM ELEVATION(FEET) = 881.21
DOWNSTREAM ELEVATION(FEET) = 878.03
ELEVATION DIFFERENCE(FEET) = 3.18
TC = $0.323 * [(217.19^{**3}) / (3.18)]^{** .2} = 6.463$
10 YEAR RAINFALL INTENSITY(INCH/HOUR) = 2.747
APARTMENT DEVELOPMENT RUNOFF COEFFICIENT = .8678
SOIL CLASSIFICATION IS "C"
SUBAREA RUNOFF(CFS) = 2.66
TOTAL AREA(ACRES) = 1.12 TOTAL RUNOFF(CFS) = 2.66

FLOW PROCESS FROM NODE 56.00 TO NODE 57.00 IS CODE = 41

>>>>COMPUTE PIPE-FLOW TRAVEL TIME THRU SUBAREA<<<<<
>>>>USING USER-SPECIFIED PIPESIZE (EXISTING ELEMENT)<<<<<

REPRESENTATIVE SLOPE = 0.0100
FLOW LENGTH(FEET) = 140.51 MANNING'S N = 0.009
ASSUME FULL-FLOWING PIPELINE
PIPE-FLOW VELOCITY(FEET/SEC.) = 7.63
PIPE FLOW VELOCITY = (TOTAL FLOW)/(PIPE CROSS SECTION AREA)
GIVEN PIPE DIAMETER(INCH) = 8.00 NUMBER OF PIPES = 1
PIPE-FLOW(CFS) = 2.66
PIPE TRAVEL TIME(MIN.) = 0.31 Tc(MIN.) = 6.77
LONGEST FLOWPATH FROM NODE 55.00 TO NODE 57.00 = 357.70 FEET.

FLOW PROCESS FROM NODE 57.00 TO NODE 57.00 IS CODE = 11

>>>>CONFLUENCE MEMORY BANK # 3 WITH THE MAIN-STREAM MEMORY<<<<<
=====

** MAIN STREAM CONFLUENCE DATA **

STREAM NUMBER	RUNOFF (CFS)	Tc (MIN.)	INTENSITY (INCH/HOUR)	AREA (ACRE)
1	2.66	6.77	2.678	1.12

LONGEST FLOWPATH FROM NODE 55.00 TO NODE 57.00 = 357.70 FEET.

** MEMORY BANK # 3 CONFLUENCE DATA **

STREAM NUMBER	RUNOFF (CFS)	Tc (MIN.)	INTENSITY (INCH/HOUR)	AREA (ACRE)
1	0.85	5.00	3.163	0.31

LONGEST FLOWPATH FROM NODE 53.00 TO NODE 57.00 = 96.84 FEET.

** PEAK FLOW RATE TABLE **

STREAM NUMBER	RUNOFF (CFS)	Tc (MIN.)	INTENSITY (INCH/HOUR)
1	2.82	5.00	3.163
2	3.39	6.77	2.678

COMPUTED CONFLUENCE ESTIMATES ARE AS FOLLOWS:

PEAK FLOW RATE(CFS) = 3.39 Tc(MIN.) = 6.77
TOTAL AREA(ACRES) = 1.4

FLOW PROCESS FROM NODE 57.00 TO NODE 57.00 IS CODE = 11

>>>>CONFLUENCE MEMORY BANK # 2 WITH THE MAIN-STREAM MEMORY<<<<<
=====

** MAIN STREAM CONFLUENCE DATA **

STREAM NUMBER	RUNOFF (CFS)	Tc (MIN.)	INTENSITY (INCH/HOUR)	AREA (ACRE)
1	2.82	5.00	3.163	1.43
2	3.39	6.77	2.678	1.43

LONGEST FLOWPATH FROM NODE 55.00 TO NODE 57.00 = 357.70 FEET.

** MEMORY BANK # 2 CONFLUENCE DATA **

STREAM NUMBER	RUNOFF (CFS)	Tc (MIN.)	INTENSITY (INCH/HOUR)	AREA (ACRE)
1	4.28	5.13	3.120	1.86
2	4.59	5.66	2.956	1.86
3	4.64	5.83	2.906	1.86
4	4.78	6.45	2.749	1.86
5	4.78	6.46	2.748	1.86

LONGEST FLOWPATH FROM NODE 44.00 TO NODE 57.00 = 533.87 FEET.

** PEAK FLOW RATE TABLE **

STREAM NUMBER	RUNOFF (CFS)	Tc (MIN.)	INTENSITY (INCH/HOUR)
1	7.00	5.00	3.163
2	7.06	5.13	3.120
3	7.42	5.66	2.956
4	7.56	5.83	2.906
5	8.01	6.45	2.749
6	8.01	6.46	2.748
7	8.05	6.77	2.678

COMPUTED CONFLUENCE ESTIMATES ARE AS FOLLOWS:

PEAK FLOW RATE(CFS) = 8.05 Tc(MIN.) = 6.77
TOTAL AREA(ACRES) = 3.3

FLOW PROCESS FROM NODE 57.00 TO NODE 57.00 IS CODE = 12

>>>>CLEAR MEMORY BANK # 2 <<<<<

FLOW PROCESS FROM NODE 57.00 TO NODE 57.00 IS CODE = 12

>>>>CLEAR MEMORY BANK # 3 <<<<<

FLOW PROCESS FROM NODE 57.00 TO NODE 58.00 IS CODE = 41

>>>>COMPUTE PIPE-FLOW TRAVEL TIME THRU SUBAREA<<<<<
>>>>USING USER-SPECIFIED PIPESIZE (EXISTING ELEMENT)<<<<<

REPRESENTATIVE SLOPE = 0.0100
FLOW LENGTH(FEET) = 77.27 MANNING'S N = 0.010
DEPTH OF FLOW IN 18.0 INCH PIPE IS 10.1 INCHES
PIPE-FLOW VELOCITY(FEET/SEC.) = 7.89
GIVEN PIPE DIAMETER(INCH) = 18.00 NUMBER OF PIPES = 1
PIPE-FLOW(CFS) = 8.05
PIPE TRAVEL TIME(MIN.) = 0.16 Tc(MIN.) = 6.93
LONGEST FLOWPATH FROM NODE 44.00 TO NODE 58.00 = 611.14 FEET.

FLOW PROCESS FROM NODE 58.00 TO NODE 58.00 IS CODE = 11

>>>>CONFLUENCE MEMORY BANK # 1 WITH THE MAIN-STREAM MEMORY<<<<<

** MAIN STREAM CONFLUENCE DATA **

STREAM NUMBER	RUNOFF (CFS)	Tc (MIN.)	INTENSITY (INCH/HOUR)	AREA (ACRE)
1	7.00	5.17	3.105	3.29
2	7.06	5.29	3.065	3.29
3	7.42	5.82	2.909	3.29
4	7.56	6.00	2.862	3.29
5	8.01	6.62	2.712	3.29
6	8.01	6.62	2.710	3.29
7	8.05	6.93	2.643	3.29

LONGEST FLOWPATH FROM NODE 44.00 TO NODE 58.00 = 611.14 FEET.

** MEMORY BANK # 1 CONFLUENCE DATA **

STREAM NUMBER	RUNOFF (CFS)	Tc (MIN.)	INTENSITY (INCH/HOUR)	AREA (ACRE)
1	11.45	7.18	2.594	16.59
2	12.05	7.48	2.535	16.59
3	12.39	7.69	2.497	16.59
4	12.42	7.70	2.494	16.59
5	12.61	7.85	2.468	16.59
6	12.70	7.91	2.458	16.59
7	12.97	8.22	2.407	16.59
8	13.69	9.23	2.259	16.59
9	13.70	9.24	2.257	16.59
10	16.33	16.40	1.647	16.59
11	19.34	21.72	1.412	16.59

LONGEST FLOWPATH FROM NODE 27.20 TO NODE 58.00 = 2735.53 FEET.

** PEAK FLOW RATE TABLE **

STREAM NUMBER	RUNOFF (CFS)	Tc (MIN.)	INTENSITY (INCH/HOUR)
1	15.33	5.17	3.105
2	15.60	5.29	3.065
3	16.80	5.82	2.909
4	17.23	6.00	2.862
5	18.68	6.62	2.712
6	18.69	6.62	2.710
7	19.22	6.93	2.643
8	19.35	7.18	2.594
9	19.77	7.48	2.535
10	19.99	7.69	2.497
11	20.01	7.70	2.494
12	20.13	7.85	2.468
13	20.19	7.91	2.458
14	20.30	8.22	2.407
15	20.57	9.23	2.259
16	20.57	9.24	2.257
17	21.35	16.40	1.647
18	23.64	21.72	1.412

COMPUTED CONFLUENCE ESTIMATES ARE AS FOLLOWS:
PEAK FLOW RATE(CFS) = 23.64 Tc(MIN.) = 21.72
TOTAL AREA(ACRES) = 19.9

FLOW PROCESS FROM NODE 58.00 TO NODE 58.00 IS CODE = 12

>>>>>CLEAR MEMORY BANK # 1 <<<<<<
=====

FLOW PROCESS FROM NODE 58.00 TO NODE 59.00 IS CODE = 41

>>>>>COMPUTE PIPE-FLOW TRAVEL TIME THRU SUBAREA<<<<<<
>>>>>USING USER-SPECIFIED PIPESIZE (EXISTING ELEMENT)<<<<<<
=====

REPRESENTATIVE SLOPE = 0.0040
FLOW LENGTH(FEET) = 109.46 MANNING'S N = 0.013
DEPTH OF FLOW IN 36.0 INCH PIPE IS 19.6 INCHES
PIPE-FLOW VELOCITY(FEET/SEC.) = 6.02
GIVEN PIPE DIAMETER(INCH) = 36.00 NUMBER OF PIPES = 1
PIPE-FLOW(CFS) = 23.64
PIPE TRAVEL TIME(MIN.) = 0.30 Tc(MIN.) = 22.02
LONGEST FLOWPATH FROM NODE 27.20 TO NODE 59.00 = 2844.99 FEET.
=====

END OF STUDY SUMMARY:

TOTAL AREA(ACRES) = 19.9 TC(MIN.) = 22.02
PEAK FLOW RATE(CFS) = 23.64

*** PEAK FLOW RATE TABLE ***

	Q(CFS)	Tc(MIN.)
1	15.33	5.51
2	15.60	5.63
3	16.80	6.15
4	17.23	6.33
5	18.68	6.94
6	18.69	6.94
7	19.22	7.25
8	19.35	7.49
9	19.77	7.79
10	19.99	8.00
11	20.01	8.02
12	20.13	8.17
13	20.19	8.23
14	20.30	8.53
15	20.57	9.54
16	20.57	9.56
17	21.35	16.71
18	23.64	22.02

=====

END OF RATIONAL METHOD ANALYSIS



RATIONAL METHOD HYDROLOGY COMPUTER PROGRAM BASED ON
RIVERSIDE COUNTY FLOOD CONTROL & WATER CONSERVATION DISTRICT
(RCFC&WCD) 1978 HYDROLOGY MANUAL
(c) Copyright 1982-2016 Advanced Engineering Software (aes)
(Rational Tabling Version 23.0)
Release Date: 07/01/2016 License ID 1681

Analysis prepared by:

KHR Associates
17530 Von Karman Avenue
Irvine, CA 92626

***** DESCRIPTION OF STUDY *****

- * IRON LOFTS *
 - * POST-DEVELOPMENT HYDROLOGY - ON-SITE PLUS OFF-SITE RUNOFF *
 - * 100-YEAR STORM EVENT *
- *****

FILE NAME: RIL1-R10.DAT
TIME/DATE OF STUDY: 09:52 08/05/2024

USER SPECIFIED HYDROLOGY AND HYDRAULIC MODEL INFORMATION:

USER SPECIFIED STORM EVENT(YEAR) = 100.00
SPECIFIED MINIMUM PIPE SIZE(INCH) = 4.00
SPECIFIED PERCENT OF GRADIENTS(DECIMAL) TO USE FOR FRICTION SLOPE = 0.95
10-YEAR STORM 10-MINUTE INTENSITY(INCH/HOUR) = 2.140
10-YEAR STORM 60-MINUTE INTENSITY(INCH/HOUR) = 0.800
100-YEAR STORM 10-MINUTE INTENSITY(INCH/HOUR) = 3.210
100-YEAR STORM 60-MINUTE INTENSITY(INCH/HOUR) = 1.200
SLOPE OF 10-YEAR INTENSITY-DURATION CURVE = 0.5491525
SLOPE OF 100-YEAR INTENSITY-DURATION CURVE = 0.5491524

COMPUTED RAINFALL INTENSITY DATA:

STORM EVENT = 100.00 1-HOUR INTENSITY(INCH/HOUR) = 1.200
SLOPE OF INTENSITY DURATION CURVE = 0.5492

RCFC&WCD HYDROLOGY MANUAL "C"-VALUES USED FOR RATIONAL METHOD

NOTE: CONSIDER ALL CONFLUENCE STREAM COMBINATIONS

FOR ALL DOWNSTREAM ANALYSES

USER-DEFINED STREET-SECTIONS FOR COUPLED PIPEFLOW AND STREETFLOW MODEL

NO.	HALF-WIDTH (FT)	CROWN TO CROSSFALL (FT)	STREET-CROSSFALL: IN-SIDE / OUT-SIDE / PARK-WAY	CURB HEIGHT (FT)	GUTTER WIDTH (FT)	GEOMETRIES: LIP (FT)	MANING: HIKE (FT)	FACTOR (n)
1	30.0	20.0	0.018/0.018/0.020	0.67	2.00	0.0313	0.167	0.0150

GLOBAL STREET FLOW-DEPTH CONSTRAINTS:

1. Relative Flow-Depth = 0.00 FEET
as (Maximum Allowable Street Flow Depth) - (Top-of-Curb)
 2. (Depth)*(Velocity) Constraint = 6.0 (FT*FT/S)
- *SIZE PIPE WITH A FLOW CAPACITY GREATER THAN
OR EQUAL TO THE UPSTREAM TRIBUTARY PIPE.*

FLOW PROCESS FROM NODE 1.00 TO NODE 2.00 IS CODE = 21

>>>>RATIONAL METHOD INITIAL SUBAREA ANALYSIS<<<<<

=====

ASSUMED INITIAL SUBAREA UNIFORM
DEVELOPMENT IS APARTMENT

TC = K*[(LENGTH**3)/(ELEVATION CHANGE)]**.2
INITIAL SUBAREA FLOW-LENGTH(FEET) = 124.00
UPSTREAM ELEVATION(FEET) = 879.50
DOWNSTREAM ELEVATION(FEET) = 877.89
ELEVATION DIFFERENCE(FEET) = 1.61
TC = 0.323*[(124.00**3)/(1.61)]**.2 = 5.290
100 YEAR RAINFALL INTENSITY(INCH/HOUR) = 4.554
APARTMENT DEVELOPMENT RUNOFF COEFFICIENT = .8791
SOIL CLASSIFICATION IS "C"
SUBAREA RUNOFF(CFS) = 1.48
TOTAL AREA(ACRES) = 0.37 TOTAL RUNOFF(CFS) = 1.48

FLOW PROCESS FROM NODE 2.00 TO NODE 2.00 IS CODE = 10

>>>>MAIN-STREAM MEMORY COPIED ONTO MEMORY BANK # 1 <<<<<

FLOW PROCESS FROM NODE 2.00 TO NODE 2.00 IS CODE = 13

>>>>CLEAR THE MAIN-STREAM MEMORY<<<<<

FLOW PROCESS FROM NODE 3.00 TO NODE 4.00 IS CODE = 21

>>>>RATIONAL METHOD INITIAL SUBAREA ANALYSIS<<<<<

=====

ASSUMED INITIAL SUBAREA UNIFORM
DEVELOPMENT IS APARTMENT

TC = K*[(LENGTH**3)/(ELEVATION CHANGE)]**.2
INITIAL SUBAREA FLOW-LENGTH(FEET) = 93.44
UPSTREAM ELEVATION(FEET) = 15.00
DOWNSTREAM ELEVATION(FEET) = 13.00
ELEVATION DIFFERENCE(FEET) = 2.00
TC = 0.323*[(93.44**3)/(2.00)]**.2 = 4.275

COMPUTED TIME OF CONCENTRATION INCREASED TO 5 MIN.

100 YEAR RAINFALL INTENSITY(INCH/HOUR) = 4.697

APARTMENT DEVELOPMENT RUNOFF COEFFICIENT = .8796

SOIL CLASSIFICATION IS "C"

SUBAREA RUNOFF(CFS) = 1.00

TOTAL AREA(ACRES) = 0.24 TOTAL RUNOFF(CFS) = 1.00

FLOW PROCESS FROM NODE 4.00 TO NODE 4.10 IS CODE = 41

>>>>COMPUTE PIPE-FLOW TRAVEL TIME THRU SUBAREA<<<<<

>>>>USING USER-SPECIFIED PIPESIZE (EXISTING ELEMENT)<<<<<

REPRESENTATIVE SLOPE = 0.0100

FLOW LENGTH(FEET) = 59.80 MANNING'S N = 0.009

ASSUME FULL-FLOWING PIPELINE

PIPE-FLOW VELOCITY(FEET/SEC.) = 5.11

PIPE FLOW VELOCITY = (TOTAL FLOW)/(PIPE CROSS SECTION AREA)

GIVEN PIPE DIAMETER(INCH) = 6.00 NUMBER OF PIPES = 1

PIPE-FLOW(CFS) = 1.00

PIPE TRAVEL TIME(MIN.) = 0.19 Tc(MIN.) = 5.19

LONGEST FLOWPATH FROM NODE 3.00 TO NODE 4.10 = 153.24 FEET.

FLOW PROCESS FROM NODE 4.10 TO NODE 5.00 IS CODE = 41

>>>>COMPUTE PIPE-FLOW TRAVEL TIME THRU SUBAREA<<<<<

>>>>USING USER-SPECIFIED PIPESIZE (EXISTING ELEMENT)<<<<<

REPRESENTATIVE SLOPE = 0.0100

FLOW LENGTH(FEET) = 13.79 MANNING'S N = 0.009

DEPTH OF FLOW IN 8.0 INCH PIPE IS 4.4 INCHES

PIPE-FLOW VELOCITY(FEET/SEC.) = 5.07

GIVEN PIPE DIAMETER(INCH) = 8.00 NUMBER OF PIPES = 1

PIPE-FLOW(CFS) = 1.00

PIPE TRAVEL TIME(MIN.) = 0.05 Tc(MIN.) = 5.24

LONGEST FLOWPATH FROM NODE 3.00 TO NODE 5.00 = 167.03 FEET.

FLOW PROCESS FROM NODE 5.00 TO NODE 5.00 IS CODE = 10

>>>>MAIN-STREAM MEMORY COPIED ONTO MEMORY BANK # 2 <<<<<

FLOW PROCESS FROM NODE 5.00 TO NODE 5.00 IS CODE = 13

>>>>CLEAR THE MAIN-STREAM MEMORY<<<<<

FLOW PROCESS FROM NODE 6.00 TO NODE 7.00 IS CODE = 21

>>>>RATIONAL METHOD INITIAL SUBAREA ANALYSIS<<<<<

ASSUMED INITIAL SUBAREA UNIFORM DEVELOPMENT IS APARTMENT

TC = K*[(LENGTH**3)/(ELEVATION CHANGE)]**.2
INITIAL SUBAREA FLOW-LENGTH(FEET) = 94.00
UPSTREAM ELEVATION(FEET) = 15.00
DOWNSTREAM ELEVATION(FEET) = 13.00
ELEVATION DIFFERENCE(FEET) = 2.00
TC = 0.323*[(94.00**3)/(2.00)]**.2 = 4.290
COMPUTED TIME OF CONCENTRATION INCREASED TO 5 MIN.
100 YEAR RAINFALL INTENSITY(INCH/HOUR) = 4.697
APARTMENT DEVELOPMENT RUNOFF COEFFICIENT = .8796
SOIL CLASSIFICATION IS "C"
SUBAREA RUNOFF(CFS) = 0.83
TOTAL AREA(ACRES) = 0.20 TOTAL RUNOFF(CFS) = 0.83

FLOW PROCESS FROM NODE 7.00 TO NODE 5.00 IS CODE = 41

>>>>COMPUTE PIPE-FLOW TRAVEL TIME THRU SUBAREA<<<<<
>>>>USING USER-SPECIFIED PIPESIZE (EXISTING ELEMENT)<<<<<

REPRESENTATIVE SLOPE = 0.0100
FLOW LENGTH(FEET) = 12.57 MANNING'S N = 0.009
ASSUME FULL-FLOWING PIPELINE
PIPE-FLOW VELOCITY(FEET/SEC.) = 9.52
PIPE FLOW VELOCITY = (TOTAL FLOW)/(PIPE CROSS SECTION AREA)
GIVEN PIPE DIAMETER(INCH) = 4.00 NUMBER OF PIPES = 1
PIPE-FLOW(CFS) = 0.83
PIPE TRAVEL TIME(MIN.) = 0.02 Tc(MIN.) = 5.02
LONGEST FLOWPATH FROM NODE 6.00 TO NODE 5.00 = 106.57 FEET.

FLOW PROCESS FROM NODE 5.00 TO NODE 5.00 IS CODE = 11

>>>>CONFLUENCE MEMORY BANK # 2 WITH THE MAIN-STREAM MEMORY<<<<<

** MAIN STREAM CONFLUENCE DATA **

STREAM RUNOFF Tc INTENSITY AREA
NUMBER (CFS) (MIN.) (INCH/HOUR) (ACRE)
1 0.83 5.02 4.686 0.20
LONGEST FLOWPATH FROM NODE 6.00 TO NODE 5.00 = 106.57 FEET.

** MEMORY BANK # 2 CONFLUENCE DATA **

STREAM RUNOFF Tc INTENSITY AREA

NUMBER	(CFS)	(MIN.)	(INCH/HOUR)	(ACRE)	
1	1.00	5.24	4.577	0.24	

LONGEST FLOWPATH FROM NODE 3.00 TO NODE 5.00 = 167.03 FEET.

** PEAK FLOW RATE TABLE **

STREAM	RUNOFF	Tc	INTENSITY
NUMBER	(CFS)	(MIN.)	(INCH/HOUR)
1	1.79	5.02	4.686
2	1.82	5.24	4.577

COMPUTED CONFLUENCE ESTIMATES ARE AS FOLLOWS:

PEAK FLOW RATE(CFS) = 1.82 Tc(MIN.) = 5.24
TOTAL AREA(ACRES) = 0.4

FLOW PROCESS FROM NODE 5.00 TO NODE 5.00 IS CODE = 12

>>>>CLEAR MEMORY BANK # 2 <<<<<

FLOW PROCESS FROM NODE 7.10 TO NODE 7.10 IS CODE = 81

>>>>ADDITION OF SUBAREA TO MAINLINE PEAK FLOW<<<<<

100 YEAR RAINFALL INTENSITY(INCH/HOUR) = 4.577
UNDEVELOPED WATERSHED RUNOFF COEFFICIENT = .7959
SOIL CLASSIFICATION IS "C"
SUBAREA AREA(ACRES) = 0.10 SUBAREA RUNOFF(CFS) = 0.37
TOTAL AREA(ACRES) = 0.5 TOTAL RUNOFF(CFS) = 2.19
TC(MIN.) = 5.24

FLOW PROCESS FROM NODE 5.00 TO NODE 2.00 IS CODE = 41

>>>>COMPUTE PIPE-FLOW TRAVEL TIME THRU SUBAREA<<<<<
>>>>USING USER-SPECIFIED PIPESIZE (EXISTING ELEMENT)<<<<<

REPRESENTATIVE SLOPE = 0.0100
FLOW LENGTH(FEET) = 78.38 MANNING'S N = 0.009
ASSUME FULL-FLOWING PIPELINE
PIPE-FLOW VELOCITY(FEET/SEC.) = 6.26
PIPE FLOW VELOCITY = (TOTAL FLOW)/(PIPE CROSS SECTION AREA)
GIVEN PIPE DIAMETER(INCH) = 8.00 NUMBER OF PIPES = 1
PIPE-FLOW(CFS) = 2.19
PIPE TRAVEL TIME(MIN.) = 0.21 Tc(MIN.) = 5.45
LONGEST FLOWPATH FROM NODE 3.00 TO NODE 2.00 = 245.41 FEET.

FLOW PROCESS FROM NODE 2.00 TO NODE 2.00 IS CODE = 11

>>>>CONFLUENCE MEMORY BANK # 1 WITH THE MAIN-STREAM MEMORY<<<<<
=====

** MAIN STREAM CONFLUENCE DATA **

STREAM NUMBER	RUNOFF (CFS)	Tc (MIN.)	INTENSITY (INCH/HOUR)	AREA (ACRE)
1	2.17	5.23	4.582	0.55
2	2.19	5.45	4.480	0.55

LONGEST FLOWPATH FROM NODE 3.00 TO NODE 2.00 = 245.41 FEET.

** MEMORY BANK # 1 CONFLUENCE DATA **

STREAM NUMBER	RUNOFF (CFS)	Tc (MIN.)	INTENSITY (INCH/HOUR)	AREA (ACRE)
1	1.48	5.29	4.554	0.37

LONGEST FLOWPATH FROM NODE 1.00 TO NODE 2.00 = 124.00 FEET.

** PEAK FLOW RATE TABLE **

STREAM NUMBER	RUNOFF (CFS)	Tc (MIN.)	INTENSITY (INCH/HOUR)
1	3.64	5.23	4.582
2	3.64	5.29	4.554
3	3.64	5.45	4.480

COMPUTED CONFLUENCE ESTIMATES ARE AS FOLLOWS:

PEAK FLOW RATE(CFS) = 3.64 Tc(MIN.) = 5.45
TOTAL AREA(ACRES) = 0.9

FLOW PROCESS FROM NODE 2.00 TO NODE 2.00 IS CODE = 12

>>>>CLEAR MEMORY BANK # 1 <<<<<
=====

FLOW PROCESS FROM NODE 2.00 TO NODE 8.00 IS CODE = 41

>>>>COMPUTE PIPE-FLOW TRAVEL TIME THRU SUBAREA<<<<<
>>>>USING USER-SPECIFIED PIPESIZE (EXISTING ELEMENT)<<<<<
=====

REPRESENTATIVE SLOPE = 0.0100
FLOW LENGTH(FEET) = 145.73 MANNING'S N = 0.009
ASSUME FULL-FLOWING PIPELINE
PIPE-FLOW VELOCITY(FEET/SEC.) = 6.68
PIPE FLOW VELOCITY = (TOTAL FLOW)/(PIPE CROSS SECTION AREA)
GIVEN PIPE DIAMETER(INCH) = 10.00 NUMBER OF PIPES = 1
PIPE-FLOW(CFS) = 3.64
PIPE TRAVEL TIME(MIN.) = 0.36 Tc(MIN.) = 5.81
LONGEST FLOWPATH FROM NODE 3.00 TO NODE 8.00 = 391.14 FEET.

FLOW PROCESS FROM NODE 8.00 TO NODE 8.00 IS CODE = 10

>>>>MAIN-STREAM MEMORY COPIED ONTO MEMORY BANK # 1 <<<<<
=====

FLOW PROCESS FROM NODE 8.00 TO NODE 8.00 IS CODE = 13

>>>>CLEAR THE MAIN-STREAM MEMORY<<<<<
=====

FLOW PROCESS FROM NODE 9.00 TO NODE 10.00 IS CODE = 21

>>>>RATIONAL METHOD INITIAL SUBAREA ANALYSIS<<<<<
=====

ASSUMED INITIAL SUBAREA UNIFORM
DEVELOPMENT IS APARTMENT
TC = K*[(LENGTH**3)/(ELEVATION CHANGE)]**.2
INITIAL SUBAREA FLOW-LENGTH(FEET) = 71.61
UPSTREAM ELEVATION(FEET) = 15.00
DOWNSTREAM ELEVATION(FEET) = 13.00
ELEVATION DIFFERENCE(FEET) = 2.00
TC = 0.323*[(71.61**3)/(2.00)]**.2 = 3.644
COMPUTED TIME OF CONCENTRATION INCREASED TO 5 MIN.
100 YEAR RAINFALL INTENSITY(INCH/HOUR) = 4.697
APARTMENT DEVELOPMENT RUNOFF COEFFICIENT = .8796
SOIL CLASSIFICATION IS "C"
SUBAREA RUNOFF(CFS) = 0.84
TOTAL AREA(ACRES) = 0.20 TOTAL RUNOFF(CFS) = 0.84

FLOW PROCESS FROM NODE 10.00 TO NODE 10.10 IS CODE = 41

>>>>COMPUTE PIPE-FLOW TRAVEL TIME THRU SUBAREA<<<<<
>>>>USING USER-SPECIFIED PIPESIZE (EXISTING ELEMENT)<<<<<
=====

REPRESENTATIVE SLOPE = 0.0100
FLOW LENGTH(FEET) = 45.35 MANNING'S N = 0.009
ASSUME FULL-FLOWING PIPELINE
PIPE-FLOW VELOCITY(FEET/SEC.) = 9.61
PIPE FLOW VELOCITY = (TOTAL FLOW)/(PIPE CROSS SECTION AREA)
GIVEN PIPE DIAMETER(INCH) = 4.00 NUMBER OF PIPES = 1
PIPE-FLOW(CFS) = 0.84
PIPE TRAVEL TIME(MIN.) = 0.08 Tc(MIN.) = 5.08
LONGEST FLOWPATH FROM NODE 9.00 TO NODE 10.10 = 116.96 FEET.

FLOW PROCESS FROM NODE 10.10 TO NODE 10.20 IS CODE = 41

>>>>COMPUTE PIPE-FLOW TRAVEL TIME THRU SUBAREA<<<<<
>>>>USING USER-SPECIFIED PIPESIZE (EXISTING ELEMENT)<<<<<

=====

REPRESENTATIVE SLOPE = 0.0100
FLOW LENGTH(FEET) = 37.68 MANNING'S N = 0.009
ASSUME FULL-FLOWING PIPELINE
PIPE-FLOW VELOCITY(FEET/SEC.) = 4.27
PIPE FLOW VELOCITY = (TOTAL FLOW)/(PIPE CROSS SECTION AREA)
GIVEN PIPE DIAMETER(INCH) = 6.00 NUMBER OF PIPES = 1
PIPE-FLOW(CFS) = 0.84
PIPE TRAVEL TIME(MIN.) = 0.15 Tc(MIN.) = 5.23
LONGEST FLOWPATH FROM NODE 9.00 TO NODE 10.20 = 154.64 FEET.

FLOW PROCESS FROM NODE 10.20 TO NODE 10.20 IS CODE = 10

>>>>MAIN-STREAM MEMORY COPIED ONTO MEMORY BANK # 3 <<<<<

FLOW PROCESS FROM NODE 10.20 TO NODE 10.20 IS CODE = 13

>>>>CLEAR THE MAIN-STREAM MEMORY<<<<<

FLOW PROCESS FROM NODE 10.30 TO NODE 10.40 IS CODE = 21

>>>>RATIONAL METHOD INITIAL SUBAREA ANALYSIS<<<<<

=====

ASSUMED INITIAL SUBAREA UNIFORM
DEVELOPMENT IS: UNDEVELOPED WITH GOOD COVER
TC = K*[(LENGTH**3)/(ELEVATION CHANGE)]**.2
INITIAL SUBAREA FLOW-LENGTH(FEET) = 17.00
UPSTREAM ELEVATION(FEET) = 878.70
DOWNSTREAM ELEVATION(FEET) = 878.32
ELEVATION DIFFERENCE(FEET) = 0.38
TC = 0.937*[(17.00**3)/(0.38)]**.2 = 6.226
100 YEAR RAINFALL INTENSITY(INCH/HOUR) = 4.164
UNDEVELOPED WATERSHED RUNOFF COEFFICIENT = .7868
SOIL CLASSIFICATION IS "C"
SUBAREA RUNOFF(CFS) = 0.28
TOTAL AREA(ACRES) = 0.08 TOTAL RUNOFF(CFS) = 0.28

FLOW PROCESS FROM NODE 10.40 TO NODE 10.20 IS CODE = 41

>>>>COMPUTE PIPE-FLOW TRAVEL TIME THRU SUBAREA<<<<<
>>>>USING USER-SPECIFIED PIPESIZE (EXISTING ELEMENT)<<<<<

```

=====
REPRESENTATIVE SLOPE = 0.0100
FLOW LENGTH(FEET) = 8.88 MANNING'S N = 0.009
ASSUME FULL-FLOWING PIPELINE
PIPE-FLOW VELOCITY(FEET/SEC.) = 3.15
PIPE FLOW VELOCITY = (TOTAL FLOW)/(PIPE CROSS SECTION AREA)
GIVEN PIPE DIAMETER(INCH) = 4.00 NUMBER OF PIPES = 1
PIPE-FLOW(CFS) = 0.28
PIPE TRAVEL TIME(MIN.) = 0.05 Tc(MIN.) = 6.27
LONGEST FLOWPATH FROM NODE 10.30 TO NODE 10.20 = 25.88 FEET.

```

```

FLOW PROCESS FROM NODE 10.20 TO NODE 10.20 IS CODE = 11
-----

```

```

>>>>>CONFLUENCE MEMORY BANK # 3 WITH THE MAIN-STREAM MEMORY<<<<<
=====

```

** MAIN STREAM CONFLUENCE DATA **

STREAM NUMBER	RUNOFF (CFS)	Tc (MIN.)	INTENSITY (INCH/HOUR)	AREA (ACRE)	
1	0.28	6.27	4.147	0.08	
LONGEST FLOWPATH FROM NODE 10.30 TO NODE 10.20 =					25.88 FEET.

** MEMORY BANK # 3 CONFLUENCE DATA **

STREAM NUMBER	RUNOFF (CFS)	Tc (MIN.)	INTENSITY (INCH/HOUR)	AREA (ACRE)	
1	0.84	5.23	4.584	0.20	
LONGEST FLOWPATH FROM NODE 9.00 TO NODE 10.20 =					154.64 FEET.

** PEAK FLOW RATE TABLE **

STREAM NUMBER	RUNOFF (CFS)	Tc (MIN.)	INTENSITY (INCH/HOUR)
1	1.07	5.23	4.584
2	1.03	6.27	4.147

COMPUTED CONFLUENCE ESTIMATES ARE AS FOLLOWS:

```

PEAK FLOW RATE(CFS) = 1.07 Tc(MIN.) = 5.23
TOTAL AREA(ACRES) = 0.3

```

```

FLOW PROCESS FROM NODE 10.20 TO NODE 10.20 IS CODE = 12
-----

```

```

>>>>>CLEAR MEMORY BANK # 3 <<<<<
=====

```

```

FLOW PROCESS FROM NODE 10.20 TO NODE 10.50 IS CODE = 41
-----

```

```

>>>>>COMPUTE PIPE-FLOW TRAVEL TIME THRU SUBAREA<<<<<
>>>>>USING USER-SPECIFIED PIPESIZE (EXISTING ELEMENT)<<<<<

```

```

=====
REPRESENTATIVE SLOPE = 0.0100
FLOW LENGTH(FEET) = 131.52 MANNING'S N = 0.009
ASSUME FULL-FLOWING PIPELINE
PIPE-FLOW VELOCITY(FEET/SEC.) = 5.44
PIPE FLOW VELOCITY = (TOTAL FLOW)/(PIPE CROSS SECTION AREA)
GIVEN PIPE DIAMETER(INCH) = 6.00 NUMBER OF PIPES = 1
PIPE-FLOW(CFS) = 1.07
PIPE TRAVEL TIME(MIN.) = 0.40 Tc(MIN.) = 5.63
LONGEST FLOWPATH FROM NODE 9.00 TO NODE 10.50 = 286.16 FEET.

```

```

FLOW PROCESS FROM NODE 10.50 TO NODE 10.50 IS CODE = 81

```

```

-----
>>>>ADDITION OF SUBAREA TO MAINLINE PEAK FLOW<<<<<

```

```

=====
100 YEAR RAINFALL INTENSITY(INCH/HOUR) = 4.401
UNDEVELOPED WATERSHED RUNOFF COEFFICIENT = .7922
SOIL CLASSIFICATION IS "C"
SUBAREA AREA(ACRES) = 0.10 SUBAREA RUNOFF(CFS) = 0.35
TOTAL AREA(ACRES) = 0.4 TOTAL RUNOFF(CFS) = 1.42
TC(MIN.) = 5.63

```

```

FLOW PROCESS FROM NODE 10.50 TO NODE 8.00 IS CODE = 41

```

```

-----
>>>>COMPUTE PIPE-FLOW TRAVEL TIME THRU SUBAREA<<<<<
>>>>USING USER-SPECIFIED PIPESIZE (EXISTING ELEMENT)<<<<<

```

```

=====
REPRESENTATIVE SLOPE = 0.0100
FLOW LENGTH(FEET) = 137.41 MANNING'S N = 0.009
DEPTH OF FLOW IN 8.0 INCH PIPE IS 5.6 INCHES
PIPE-FLOW VELOCITY(FEET/SEC.) = 5.47
GIVEN PIPE DIAMETER(INCH) = 8.00 NUMBER OF PIPES = 1
PIPE-FLOW(CFS) = 1.42
PIPE TRAVEL TIME(MIN.) = 0.42 Tc(MIN.) = 6.05
LONGEST FLOWPATH FROM NODE 9.00 TO NODE 8.00 = 423.57 FEET.

```

```

FLOW PROCESS FROM NODE 8.00 TO NODE 8.00 IS CODE = 11

```

```

-----
>>>>CONFLUENCE MEMORY BANK # 1 WITH THE MAIN-STREAM MEMORY<<<<<

```

** MAIN STREAM CONFLUENCE DATA **

STREAM NUMBER	RUNOFF (CFS)	Tc (MIN.)	INTENSITY (INCH/HOUR)	AREA (ACRE)
1	1.42	6.05	4.231	0.39
2	1.35	7.11	3.870	0.39

```

LONGEST FLOWPATH FROM NODE 9.00 TO NODE 8.00 = 423.57 FEET.

```

** MEMORY BANK # 1 CONFLUENCE DATA **

STREAM NUMBER	RUNOFF (CFS)	Tc (MIN.)	INTENSITY (INCH/HOUR)	AREA (ACRE)
1	3.64	5.60	4.415	0.92
2	3.64	5.65	4.390	0.92
3	3.64	5.81	4.324	0.92

LONGEST FLOWPATH FROM NODE 3.00 TO NODE 8.00 = 391.14 FEET.

** PEAK FLOW RATE TABLE **

STREAM NUMBER	RUNOFF (CFS)	Tc (MIN.)	INTENSITY (INCH/HOUR)
1	4.95	5.60	4.415
2	4.97	5.65	4.390
3	5.01	5.81	4.324
4	4.98	6.05	4.231
5	4.61	7.11	3.870

COMPUTED CONFLUENCE ESTIMATES ARE AS FOLLOWS:

PEAK FLOW RATE(CFS) = 5.01 Tc(MIN.) = 5.81
TOTAL AREA(ACRES) = 1.3

FLOW PROCESS FROM NODE 8.00 TO NODE 8.00 IS CODE = 12

>>>>CLEAR MEMORY BANK # 1 <<<<<

FLOW PROCESS FROM NODE 8.00 TO NODE 13.00 IS CODE = 41

>>>>COMPUTE PIPE-FLOW TRAVEL TIME THRU SUBAREA<<<<<
>>>>USING USER-SPECIFIED PIPESIZE (EXISTING ELEMENT)<<<<<

REPRESENTATIVE SLOPE = 0.0100
FLOW LENGTH(FEET) = 38.12 MANNING'S N = 0.009
ASSUME FULL-FLOWING PIPELINE
PIPE-FLOW VELOCITY(FEET/SEC.) = 9.18
PIPE FLOW VELOCITY = (TOTAL FLOW)/(PIPE CROSS SECTION AREA)
GIVEN PIPE DIAMETER(INCH) = 10.00 NUMBER OF PIPES = 1
PIPE-FLOW(CFS) = 5.01
PIPE TRAVEL TIME(MIN.) = 0.07 Tc(MIN.) = 5.88
LONGEST FLOWPATH FROM NODE 9.00 TO NODE 13.00 = 461.69 FEET.

FLOW PROCESS FROM NODE 13.00 TO NODE 13.00 IS CODE = 10

>>>>MAIN-STREAM MEMORY COPIED ONTO MEMORY BANK # 1 <<<<<

FLOW PROCESS FROM NODE 13.00 TO NODE 13.00 IS CODE = 13

>>>>CLEAR THE MAIN-STREAM MEMORY<<<<<

FLOW PROCESS FROM NODE 11.00 TO NODE 12.00 IS CODE = 21

>>>>RATIONAL METHOD INITIAL SUBAREA ANALYSIS<<<<<

ASSUMED INITIAL SUBAREA UNIFORM DEVELOPMENT IS APARTMENT

TC = K*[(LENGTH**3)/(ELEVATION CHANGE)]**.2

INITIAL SUBAREA FLOW-LENGTH(FEET) = 36.94

UPSTREAM ELEVATION(FEET) = 15.00

DOWNSTREAM ELEVATION(FEET) = 13.00

ELEVATION DIFFERENCE(FEET) = 2.00

TC = 0.323*[(36.94**3)/(2.00)]**.2 = 2.450

COMPUTED TIME OF CONCENTRATION INCREASED TO 5 MIN.

100 YEAR RAINFALL INTENSITY(INCH/HOUR) = 4.697

APARTMENT DEVELOPMENT RUNOFF COEFFICIENT = .8796

SOIL CLASSIFICATION IS "C"

SUBAREA RUNOFF(CFS) = 0.21

TOTAL AREA(ACRES) = 0.05 TOTAL RUNOFF(CFS) = 0.21

FLOW PROCESS FROM NODE 12.00 TO NODE 13.00 IS CODE = 41

>>>>COMPUTE PIPE-FLOW TRAVEL TIME THRU SUBAREA<<<<<

>>>>USING USER-SPECIFIED PIPESIZE (EXISTING ELEMENT)<<<<<

REPRESENTATIVE SLOPE = 0.0100

FLOW LENGTH(FEET) = 41.32 MANNING'S N = 0.009

DEPTH OF FLOW IN 4.0 INCH PIPE IS 2.7 INCHES

PIPE-FLOW VELOCITY(FEET/SEC.) = 3.34

GIVEN PIPE DIAMETER(INCH) = 4.00 NUMBER OF PIPES = 1

PIPE-FLOW(CFS) = 0.21

PIPE TRAVEL TIME(MIN.) = 0.21 Tc(MIN.) = 5.21

LONGEST FLOWPATH FROM NODE 11.00 TO NODE 13.00 = 78.26 FEET.

FLOW PROCESS FROM NODE 13.00 TO NODE 13.00 IS CODE = 11

>>>>CONFLUENCE MEMORY BANK # 1 WITH THE MAIN-STREAM MEMORY<<<<<

** MAIN STREAM CONFLUENCE DATA **

STREAM NUMBER	RUNOFF (CFS)	Tc (MIN.)	INTENSITY (INCH/HOUR)	AREA (ACRE)
---------------	--------------	-----------	-----------------------	-------------

1 0.21 5.21 4.594 0.05
LONGEST FLOWPATH FROM NODE 11.00 TO NODE 13.00 = 78.26 FEET.

** MEMORY BANK # 1 CONFLUENCE DATA **

STREAM NUMBER	RUNOFF (CFS)	Tc (MIN.)	INTENSITY (INCH/HOUR)	AREA (ACRE)
1	4.95	5.67	4.385	1.30
2	4.97	5.72	4.361	1.30
3	5.01	5.88	4.296	1.30
4	4.98	6.12	4.205	1.30
5	4.61	7.19	3.848	1.30

LONGEST FLOWPATH FROM NODE 9.00 TO NODE 13.00 = 461.69 FEET.

** PEAK FLOW RATE TABLE **

STREAM NUMBER	RUNOFF (CFS)	Tc (MIN.)	INTENSITY (INCH/HOUR)
1	4.75	5.21	4.594
2	5.15	5.67	4.385
3	5.16	5.72	4.361
4	5.20	5.88	4.296
5	5.17	6.12	4.205
6	4.78	7.19	3.848

COMPUTED CONFLUENCE ESTIMATES ARE AS FOLLOWS:

PEAK FLOW RATE(CFS) = 5.20 Tc(MIN.) = 5.88
TOTAL AREA(ACRES) = 1.4

FLOW PROCESS FROM NODE 13.00 TO NODE 13.00 IS CODE = 12

>>>>CLEAR MEMORY BANK # 1 <<<<<

FLOW PROCESS FROM NODE 13.00 TO NODE 13.00 IS CODE = 10

>>>>MAIN-STREAM MEMORY COPIED ONTO MEMORY BANK # 1 <<<<<

FLOW PROCESS FROM NODE 13.00 TO NODE 13.00 IS CODE = 13

>>>>CLEAR THE MAIN-STREAM MEMORY<<<<<

FLOW PROCESS FROM NODE 14.00 TO NODE 15.00 IS CODE = 21

>>>>RATIONAL METHOD INITIAL SUBAREA ANALYSIS<<<<<

ASSUMED INITIAL SUBAREA UNIFORM
DEVELOPMENT IS APARTMENT

TC = $K * [(LENGTH^{**3}) / (ELEVATION CHANGE)]^{**0.2}$
 INITIAL SUBAREA FLOW-LENGTH(FEET) = 282.36
 UPSTREAM ELEVATION(FEET) = 881.50
 DOWNSTREAM ELEVATION(FEET) = 877.80
 ELEVATION DIFFERENCE(FEET) = 3.70
 TC = $0.323 * [(282.36^{**3}) / (3.70)]^{**0.2} = 7.339$
 100 YEAR RAINFALL INTENSITY(INCH/HOUR) = 3.804
 APARTMENT DEVELOPMENT RUNOFF COEFFICIENT = .8755
 SOIL CLASSIFICATION IS "C"
 SUBAREA RUNOFF(CFS) = 4.41
 TOTAL AREA(ACRES) = 1.32 TOTAL RUNOFF(CFS) = 4.41

 FLOW PROCESS FROM NODE 15.00 TO NODE 15.00 IS CODE = 11

 >>>>CONFLUENCE MEMORY BANK # 1 WITH THE MAIN-STREAM MEMORY<<<<<
 =====

** MAIN STREAM CONFLUENCE DATA **

STREAM NUMBER	RUNOFF (CFS)	Tc (MIN.)	INTENSITY (INCH/HOUR)	AREA (ACRE)
1	4.41	7.34	3.804	1.32

LONGEST FLOWPATH FROM NODE 14.00 TO NODE 15.00 = 282.36 FEET.

** MEMORY BANK # 1 CONFLUENCE DATA **

STREAM NUMBER	RUNOFF (CFS)	Tc (MIN.)	INTENSITY (INCH/HOUR)	AREA (ACRE)
1	4.75	5.21	4.594	1.35
2	5.15	5.67	4.385	1.35
3	5.16	5.72	4.361	1.35
4	5.20	5.88	4.296	1.35
5	5.17	6.12	4.205	1.35
6	4.78	7.19	3.848	1.35

LONGEST FLOWPATH FROM NODE 9.00 TO NODE 15.00 = 461.69 FEET.

** PEAK FLOW RATE TABLE **

STREAM NUMBER	RUNOFF (CFS)	Tc (MIN.)	INTENSITY (INCH/HOUR)
1	7.88	5.21	4.594
2	8.55	5.67	4.385
3	8.60	5.72	4.361
4	8.73	5.88	4.296
5	8.84	6.12	4.205
6	9.10	7.19	3.848
7	9.13	7.34	3.804

COMPUTED CONFLUENCE ESTIMATES ARE AS FOLLOWS:

PEAK FLOW RATE(CFS) = 9.13 Tc(MIN.) = 7.34

TOTAL AREA(ACRES) = 2.7

FLOW PROCESS FROM NODE 15.00 TO NODE 15.00 IS CODE = 12

>>>>CLEAR MEMORY BANK # 1 <<<<<

FLOW PROCESS FROM NODE 15.00 TO NODE 15.00 IS CODE = 10

>>>>MAIN-STREAM MEMORY COPIED ONTO MEMORY BANK # 1 <<<<<

FLOW PROCESS FROM NODE 15.00 TO NODE 15.00 IS CODE = 13

>>>>CLEAR THE MAIN-STREAM MEMORY<<<<<

FLOW PROCESS FROM NODE 16.00 TO NODE 17.00 IS CODE = 21

>>>>RATIONAL METHOD INITIAL SUBAREA ANALYSIS<<<<<

=====

ASSUMED INITIAL SUBAREA UNIFORM
DEVELOPMENT IS APARTMENT

TC = $K * [(LENGTH^{**3}) / (ELEVATION CHANGE)]^{**0.2}$

INITIAL SUBAREA FLOW-LENGTH(FEET) = 74.23

UPSTREAM ELEVATION(FEET) = 15.00

DOWNSTREAM ELEVATION(FEET) = 13.00

ELEVATION DIFFERENCE(FEET) = 2.00

TC = $0.323 * [(74.23^{**3}) / (2.00)]^{**0.2} = 3.723$

COMPUTED TIME OF CONCENTRATION INCREASED TO 5 MIN.

100 YEAR RAINFALL INTENSITY(INCH/HOUR) = 4.697

APARTMENT DEVELOPMENT RUNOFF COEFFICIENT = .8796

SOIL CLASSIFICATION IS "C"

SUBAREA RUNOFF(CFS) = 1.19

TOTAL AREA(ACRES) = 0.29 TOTAL RUNOFF(CFS) = 1.19

FLOW PROCESS FROM NODE 17.00 TO NODE 17.10 IS CODE = 41

>>>>COMPUTE PIPE-FLOW TRAVEL TIME THRU SUBAREA<<<<<

>>>>USING USER-SPECIFIED PIPESIZE (EXISTING ELEMENT)<<<<<

=====

REPRESENTATIVE SLOPE = 0.0100

FLOW LENGTH(FEET) = 15.20 MANNING'S N = 0.009

ASSUME FULL-FLOWING PIPELINE

PIPE-FLOW VELOCITY(FEET/SEC.) = 13.68

PIPE FLOW VELOCITY = (TOTAL FLOW)/(PIPE CROSS SECTION AREA)
GIVEN PIPE DIAMETER(INCH) = 4.00 NUMBER OF PIPES = 1
PIPE-FLOW(CFS) = 1.19
PIPE TRAVEL TIME(MIN.) = 0.02 Tc(MIN.) = 5.02
LONGEST FLOWPATH FROM NODE 16.00 TO NODE 17.10 = 89.43 FEET.

FLOW PROCESS FROM NODE 17.00 TO NODE 18.00 IS CODE = 41

>>>>COMPUTE PIPE-FLOW TRAVEL TIME THRU SUBAREA<<<<<
>>>>USING USER-SPECIFIED PIPESIZE (EXISTING ELEMENT)<<<<<

=====

REPRESENTATIVE SLOPE = 0.0100
FLOW LENGTH(FEET) = 164.51 MANNING'S N = 0.009
DEPTH OF FLOW IN 8.0 INCH PIPE IS 4.9 INCHES
PIPE-FLOW VELOCITY(FEET/SEC.) = 5.27
GIVEN PIPE DIAMETER(INCH) = 8.00 NUMBER OF PIPES = 1
PIPE-FLOW(CFS) = 1.19
PIPE TRAVEL TIME(MIN.) = 0.52 Tc(MIN.) = 5.54
LONGEST FLOWPATH FROM NODE 16.00 TO NODE 18.00 = 253.94 FEET.

FLOW PROCESS FROM NODE 18.00 TO NODE 18.00 IS CODE = 10

>>>>MAIN-STREAM MEMORY COPIED ONTO MEMORY BANK # 2 <<<<<

FLOW PROCESS FROM NODE 18.00 TO NODE 18.00 IS CODE = 13

>>>>CLEAR THE MAIN-STREAM MEMORY<<<<<

FLOW PROCESS FROM NODE 19.00 TO NODE 20.00 IS CODE = 21

>>>>RATIONAL METHOD INITIAL SUBAREA ANALYSIS<<<<<

=====

ASSUMED INITIAL SUBAREA UNIFORM
DEVELOPMENT IS APARTMENT
TC = K*[(LENGTH**3)/(ELEVATION CHANGE)]**.2
INITIAL SUBAREA FLOW-LENGTH(FEET) = 147.00
UPSTREAM ELEVATION(FEET) = 881.00
DOWNSTREAM ELEVATION(FEET) = 878.08
ELEVATION DIFFERENCE(FEET) = 2.92
TC = 0.323*[(147.00**3)/(2.92)]**.2 = 5.201
100 YEAR RAINFALL INTENSITY(INCH/HOUR) = 4.596
APARTMENT DEVELOPMENT RUNOFF COEFFICIENT = .8792
SOIL CLASSIFICATION IS "C"
SUBAREA RUNOFF(CFS) = 1.27

TOTAL AREA(ACRES) = 0.31 TOTAL RUNOFF(CFS) = 1.27

FLOW PROCESS FROM NODE 20.00 TO NODE 20.00 IS CODE = 11

>>>>CONFLUENCE MEMORY BANK # 2 WITH THE MAIN-STREAM MEMORY<<<<<

** MAIN STREAM CONFLUENCE DATA **

STREAM NUMBER	RUNOFF (CFS)	Tc (MIN.)	INTENSITY (INCH/HOUR)	AREA (ACRE)
1	1.27	5.20	4.596	0.31

LONGEST FLOWPATH FROM NODE 19.00 TO NODE 20.00 = 147.00 FEET.

** MEMORY BANK # 2 CONFLUENCE DATA **

STREAM NUMBER	RUNOFF (CFS)	Tc (MIN.)	INTENSITY (INCH/HOUR)	AREA (ACRE)
1	1.19	5.54	4.440	0.29

LONGEST FLOWPATH FROM NODE 16.00 TO NODE 20.00 = 253.94 FEET.

** PEAK FLOW RATE TABLE **

STREAM NUMBER	RUNOFF (CFS)	Tc (MIN.)	INTENSITY (INCH/HOUR)
1	2.39	5.20	4.596
2	2.42	5.54	4.440

COMPUTED CONFLUENCE ESTIMATES ARE AS FOLLOWS:

PEAK FLOW RATE(CFS) = 2.42 Tc(MIN.) = 5.54
TOTAL AREA(ACRES) = 0.6

FLOW PROCESS FROM NODE 20.00 TO NODE 20.00 IS CODE = 12

>>>>CLEAR MEMORY BANK # 2 <<<<<

FLOW PROCESS FROM NODE 20.00 TO NODE 21.00 IS CODE = 41

>>>>COMPUTE PIPE-FLOW TRAVEL TIME THRU SUBAREA<<<<<
>>>>USING USER-SPECIFIED PIPESIZE (EXISTING ELEMENT)<<<<<

REPRESENTATIVE SLOPE = 0.0100
FLOW LENGTH(FEET) = 35.92 MANNING'S N = 0.009
ASSUME FULL-FLOWING PIPELINE
PIPE-FLOW VELOCITY(FEET/SEC.) = 12.34
PIPE FLOW VELOCITY = (TOTAL FLOW)/(PIPE CROSS SECTION AREA)
GIVEN PIPE DIAMETER(INCH) = 6.00 NUMBER OF PIPES = 1
PIPE-FLOW(CFS) = 2.42
PIPE TRAVEL TIME(MIN.) = 0.05 Tc(MIN.) = 5.59

LONGEST FLOWPATH FROM NODE 16.00 TO NODE 21.00 = 289.86 FEET.

FLOW PROCESS FROM NODE 21.00 TO NODE 21.00 IS CODE = 10

>>>>MAIN-STREAM MEMORY COPIED ONTO MEMORY BANK # 2 <<<<<

FLOW PROCESS FROM NODE 21.00 TO NODE 21.00 IS CODE = 13

>>>>CLEAR THE MAIN-STREAM MEMORY<<<<<

FLOW PROCESS FROM NODE 22.00 TO NODE 23.00 IS CODE = 21

>>>>RATIONAL METHOD INITIAL SUBAREA ANALYSIS<<<<<

ASSUMED INITIAL SUBAREA UNIFORM

DEVELOPMENT IS: UNDEVELOPED WITH GOOD COVER

$TC = K * [(LENGTH^{**3}) / (ELEVATION CHANGE)]^{** .2}$

INITIAL SUBAREA FLOW-LENGTH(FEET) = 77.86

UPSTREAM ELEVATION(FEET) = 881.47

DOWNSTREAM ELEVATION(FEET) = 880.67

ELEVATION DIFFERENCE(FEET) = 0.80

$TC = 0.937 * [(77.86^{**3}) / (0.80)]^{** .2} = 13.369$

100 YEAR RAINFALL INTENSITY(INCH/HOUR) = 2.737

UNDEVELOPED WATERSHED RUNOFF COEFFICIENT = .7384

SOIL CLASSIFICATION IS "C"

SUBAREA RUNOFF(CFS) = 0.20

TOTAL AREA(ACRES) = 0.10 TOTAL RUNOFF(CFS) = 0.20

FLOW PROCESS FROM NODE 23.00 TO NODE 21.00 IS CODE = 41

>>>>COMPUTE PIPE-FLOW TRAVEL TIME THRU SUBAREA<<<<<

>>>>USING USER-SPECIFIED PIPESIZE (EXISTING ELEMENT)<<<<<

REPRESENTATIVE SLOPE = 0.0100

FLOW LENGTH(FEET) = 107.21 MANNING'S N = 0.009

DEPTH OF FLOW IN 6.0 INCH PIPE IS 2.1 INCHES

PIPE-FLOW VELOCITY(FEET/SEC.) = 3.40

GIVEN PIPE DIAMETER(INCH) = 6.00 NUMBER OF PIPES = 1

PIPE-FLOW(CFS) = 0.20

PIPE TRAVEL TIME(MIN.) = 0.53 $T_c(MIN.) = 13.90$

LONGEST FLOWPATH FROM NODE 22.00 TO NODE 21.00 = 185.07 FEET.

FLOW PROCESS FROM NODE 21.00 TO NODE 21.00 IS CODE = 11

>>>>>CONFLUENCE MEMORY BANK # 2 WITH THE MAIN-STREAM MEMORY<<<<<<
=====

** MAIN STREAM CONFLUENCE DATA **

STREAM NUMBER	RUNOFF (CFS)	Tc (MIN.)	INTENSITY (INCH/HOUR)	AREA (ACRE)	
1	0.20	13.90	2.679	0.10	
LONGEST FLOWPATH FROM NODE					22.00 TO NODE 21.00 = 185.07 FEET.

** MEMORY BANK # 2 CONFLUENCE DATA **

STREAM NUMBER	RUNOFF (CFS)	Tc (MIN.)	INTENSITY (INCH/HOUR)	AREA (ACRE)	
1	2.39	5.25	4.573	0.60	
2	2.42	5.59	4.419	0.60	
LONGEST FLOWPATH FROM NODE					16.00 TO NODE 21.00 = 289.86 FEET.

** PEAK FLOW RATE TABLE **

STREAM NUMBER	RUNOFF (CFS)	Tc (MIN.)	INTENSITY (INCH/HOUR)
1	2.47	5.25	4.573
2	2.51	5.59	4.419
3	1.67	13.90	2.679

COMPUTED CONFLUENCE ESTIMATES ARE AS FOLLOWS:

PEAK FLOW RATE(CFS) = 2.51 Tc(MIN.) = 5.59
TOTAL AREA(ACRES) = 0.7

FLOW PROCESS FROM NODE 21.00 TO NODE 21.00 IS CODE = 12

>>>>>CLEAR MEMORY BANK # 2 <<<<<<
=====

FLOW PROCESS FROM NODE 21.00 TO NODE 24.00 IS CODE = 41

>>>>>COMPUTE PIPE-FLOW TRAVEL TIME THRU SUBAREA<<<<<<
>>>>>USING USER-SPECIFIED PIPESIZE (EXISTING ELEMENT)<<<<<<
=====

REPRESENTATIVE SLOPE = 0.0100
FLOW LENGTH(FEET) = 136.64 MANNING'S N = 0.009
ASSUME FULL-FLOWING PIPELINE
PIPE-FLOW VELOCITY(FEET/SEC.) = 12.76
PIPE FLOW VELOCITY = (TOTAL FLOW)/(PIPE CROSS SECTION AREA)
GIVEN PIPE DIAMETER(INCH) = 6.00 NUMBER OF PIPES = 1
PIPE-FLOW(CFS) = 2.51
PIPE TRAVEL TIME(MIN.) = 0.18 Tc(MIN.) = 5.77
LONGEST FLOWPATH FROM NODE 16.00 TO NODE 24.00 = 426.50 FEET.

FLOW PROCESS FROM NODE 24.00 TO NODE 24.00 IS CODE = 11

>>>>CONFLUENCE MEMORY BANK # 1 WITH THE MAIN-STREAM MEMORY<<<<<

** MAIN STREAM CONFLUENCE DATA **

STREAM NUMBER	RUNOFF (CFS)	Tc (MIN.)	INTENSITY (INCH/HOUR)	AREA (ACRE)
1	2.47	5.43	4.488	0.70
2	2.51	5.77	4.344	0.70
3	1.67	14.16	2.652	0.70
LONGEST FLOWPATH FROM NODE 16.00 TO NODE 24.00 = 426.50 FEET.				

** MEMORY BANK # 1 CONFLUENCE DATA **

STREAM NUMBER	RUNOFF (CFS)	Tc (MIN.)	INTENSITY (INCH/HOUR)	AREA (ACRE)
1	7.88	5.21	4.594	2.68
2	8.55	5.67	4.385	2.68
3	8.60	5.72	4.361	2.68
4	8.73	5.88	4.296	2.68
5	8.84	6.12	4.205	2.68
6	9.10	7.19	3.848	2.68
7	9.13	7.34	3.804	2.68
LONGEST FLOWPATH FROM NODE 9.00 TO NODE 24.00 = 461.69 FEET.				

** PEAK FLOW RATE TABLE **

STREAM NUMBER	RUNOFF (CFS)	Tc (MIN.)	INTENSITY (INCH/HOUR)
1	10.25	5.21	4.594
2	10.67	5.43	4.488
3	11.01	5.67	4.385
4	11.09	5.72	4.361
5	11.07	5.77	4.344
6	11.21	5.88	4.296
7	11.27	6.12	4.205
8	11.32	7.19	3.848
9	11.33	7.34	3.804
10	8.04	14.16	2.652

COMPUTED CONFLUENCE ESTIMATES ARE AS FOLLOWS:

PEAK FLOW RATE(CFS) = 11.33 Tc(MIN.) = 7.34
TOTAL AREA(ACRES) = 3.4

FLOW PROCESS FROM NODE 24.00 TO NODE 24.00 IS CODE = 12

>>>>CLEAR MEMORY BANK # 1 <<<<<

FLOW PROCESS FROM NODE 24.00 TO NODE 25.00 IS CODE = 41

>>>>COMPUTE PIPE-FLOW TRAVEL TIME THRU SUBAREA<<<<<
>>>>USING USER-SPECIFIED PIPESIZE (EXISTING ELEMENT)<<<<<

=====
REPRESENTATIVE SLOPE = 0.0100
FLOW LENGTH(FEET) = 55.93 MANNING'S N = 0.009
ASSUME FULL-FLOWING PIPELINE
PIPE-FLOW VELOCITY(FEET/SEC.) = 57.70
PIPE FLOW VELOCITY = (TOTAL FLOW)/(PIPE CROSS SECTION AREA)
GIVEN PIPE DIAMETER(INCH) = 6.00 NUMBER OF PIPES = 1
PIPE-FLOW(CFS) = 11.33
PIPE TRAVEL TIME(MIN.) = 0.02 Tc(MIN.) = 7.36
LONGEST FLOWPATH FROM NODE 9.00 TO NODE 25.00 = 517.62 FEET.

FLOW PROCESS FROM NODE 26.00 TO NODE 27.00 IS CODE = 41

>>>>COMPUTE PIPE-FLOW TRAVEL TIME THRU SUBAREA<<<<<
>>>>USING USER-SPECIFIED PIPESIZE (EXISTING ELEMENT)<<<<<

=====
REPRESENTATIVE SLOPE = 0.0040
FLOW LENGTH(FEET) = 255.17 MANNING'S N = 0.010
ASSUME FULL-FLOWING PIPELINE
PIPE-FLOW VELOCITY(FEET/SEC.) = 6.41
PIPE FLOW VELOCITY = (TOTAL FLOW)/(PIPE CROSS SECTION AREA)
GIVEN PIPE DIAMETER(INCH) = 18.00 NUMBER OF PIPES = 1
PIPE-FLOW(CFS) = 11.33
PIPE TRAVEL TIME(MIN.) = 0.66 Tc(MIN.) = 8.02
LONGEST FLOWPATH FROM NODE 9.00 TO NODE 27.00 = 772.79 FEET.

FLOW PROCESS FROM NODE 27.00 TO NODE 27.10 IS CODE = 41

>>>>COMPUTE PIPE-FLOW TRAVEL TIME THRU SUBAREA<<<<<
>>>>USING USER-SPECIFIED PIPESIZE (EXISTING ELEMENT)<<<<<

=====
REPRESENTATIVE SLOPE = 0.0040
FLOW LENGTH(FEET) = 279.97 MANNING'S N = 0.010
ASSUME FULL-FLOWING PIPELINE
PIPE-FLOW VELOCITY(FEET/SEC.) = 6.41
PIPE FLOW VELOCITY = (TOTAL FLOW)/(PIPE CROSS SECTION AREA)
GIVEN PIPE DIAMETER(INCH) = 18.00 NUMBER OF PIPES = 1
PIPE-FLOW(CFS) = 11.33
PIPE TRAVEL TIME(MIN.) = 0.73 Tc(MIN.) = 8.75
LONGEST FLOWPATH FROM NODE 9.00 TO NODE 27.10 = 1052.76 FEET.

FLOW PROCESS FROM NODE 27.10 TO NODE 27.10 IS CODE = 10

>>>>MAIN-STREAM MEMORY COPIED ONTO MEMORY BANK # 1 <<<<<
=====

FLOW PROCESS FROM NODE 27.10 TO NODE 27.10 IS CODE = 13

>>>>CLEAR THE MAIN-STREAM MEMORY<<<<<
=====

FLOW PROCESS FROM NODE 27.20 TO NODE 27.30 IS CODE = 21

>>>>RATIONAL METHOD INITIAL SUBAREA ANALYSIS<<<<<
=====

ASSUMED INITIAL SUBAREA UNIFORM
DEVELOPMENT IS SINGLE FAMILY (1/4 ACRE)
TC = $K * [(LENGTH^{**3}) / (ELEVATION CHANGE)]^{**0.2}$
INITIAL SUBAREA FLOW-LENGTH(FEET) = 2313.53
UPSTREAM ELEVATION(FEET) = 910.75
DOWNSTREAM ELEVATION(FEET) = 881.40
ELEVATION DIFFERENCE(FEET) = 29.35
TC = $0.393 * [(2313.53^{**3}) / (29.35)]^{**0.2} = 20.845$
100 YEAR RAINFALL INTENSITY(INCH/HOUR) = 2.145
SINGLE-FAMILY(1/4 ACRE LOT) RUNOFF COEFFICIENT = .8017
SOIL CLASSIFICATION IS "C"
SUBAREA RUNOFF(CFS) = 22.71
TOTAL AREA(ACRES) = 13.21 TOTAL RUNOFF(CFS) = 22.71

FLOW PROCESS FROM NODE 27.30 TO NODE 27.40 IS CODE = 41

>>>>COMPUTE PIPE-FLOW TRAVEL TIME THRU SUBAREA<<<<<
>>>>USING USER-SPECIFIED PIPESIZE (EXISTING ELEMENT)<<<<<
=====

REPRESENTATIVE SLOPE = 0.0125
FLOW LENGTH(FEET) = 22.90 MANNING'S N = 0.013
DEPTH OF FLOW IN 24.0 INCH PIPE IS 18.2 INCHES
PIPE-FLOW VELOCITY(FEET/SEC.) = 8.90
GIVEN PIPE DIAMETER(INCH) = 24.00 NUMBER OF PIPES = 1
PIPE-FLOW(CFS) = 22.71
PIPE TRAVEL TIME(MIN.) = 0.04 Tc(MIN.) = 20.89
LONGEST FLOWPATH FROM NODE 27.20 TO NODE 27.40 = 2336.43 FEET.

FLOW PROCESS FROM NODE 27.40 TO NODE 27.50 IS CODE = 41

>>>>COMPUTE PIPE-FLOW TRAVEL TIME THRU SUBAREA<<<<<
>>>>USING USER-SPECIFIED PIPESIZE (EXISTING ELEMENT)<<<<<
=====

REPRESENTATIVE SLOPE = 0.0150
 FLOW LENGTH(FEET) = 221.35 MANNING'S N = 0.013
 DEPTH OF FLOW IN 24.0 INCH PIPE IS 16.9 INCHES
 PIPE-FLOW VELOCITY(FEET/SEC.) = 9.63
 GIVEN PIPE DIAMETER(INCH) = 24.00 NUMBER OF PIPES = 1
 PIPE-FLOW(CFS) = 22.71
 PIPE TRAVEL TIME(MIN.) = 0.38 Tc(MIN.) = 21.27
 LONGEST FLOWPATH FROM NODE 27.20 TO NODE 27.50 = 2557.78 FEET.

FLOW PROCESS FROM NODE 27.50 TO NODE 27.10 IS CODE = 41

>>>>COMPUTE PIPE-FLOW TRAVEL TIME THRU SUBAREA<<<<<
 >>>>USING USER-SPECIFIED PIPESIZE (EXISTING ELEMENT)<<<<<

REPRESENTATIVE SLOPE = 0.0150
 FLOW LENGTH(FEET) = 106.50 MANNING'S N = 0.013
 DEPTH OF FLOW IN 24.0 INCH PIPE IS 16.9 INCHES
 PIPE-FLOW VELOCITY(FEET/SEC.) = 9.63
 GIVEN PIPE DIAMETER(INCH) = 24.00 NUMBER OF PIPES = 1
 PIPE-FLOW(CFS) = 22.71
 PIPE TRAVEL TIME(MIN.) = 0.18 Tc(MIN.) = 21.45
 LONGEST FLOWPATH FROM NODE 27.20 TO NODE 27.10 = 2664.28 FEET.

FLOW PROCESS FROM NODE 27.10 TO NODE 27.10 IS CODE = 11

>>>>CONFLUENCE MEMORY BANK # 1 WITH THE MAIN-STREAM MEMORY<<<<<

** MAIN STREAM CONFLUENCE DATA **

STREAM NUMBER	RUNOFF (CFS)	Tc (MIN.)	INTENSITY (INCH/HOUR)	AREA (ACRE)
1	22.71	21.45	2.111	13.21

LONGEST FLOWPATH FROM NODE 27.20 TO NODE 27.10 = 2664.28 FEET.

** MEMORY BANK # 1 CONFLUENCE DATA **

STREAM NUMBER	RUNOFF (CFS)	Tc (MIN.)	INTENSITY (INCH/HOUR)	AREA (ACRE)
1	10.25	6.76	3.980	3.38
2	10.67	6.93	3.927	3.38
3	11.01	7.11	3.870	3.38
4	11.09	7.16	3.856	3.38
5	11.07	7.21	3.843	3.38
6	11.21	7.30	3.814	3.38
7	11.27	7.53	3.751	3.38
8	11.32	8.60	3.488	3.38
9	11.33	8.75	3.455	3.38
10	8.04	15.83	2.494	3.38

LONGEST FLOWPATH FROM NODE 9.00 TO NODE 27.10 = 1052.76 FEET.

** PEAK FLOW RATE TABLE **

STREAM NUMBER	RUNOFF (CFS)	Tc (MIN.)	INTENSITY (INCH/HOUR)
1	17.41	6.76	3.980
2	18.00	6.93	3.927
3	18.54	7.11	3.870
4	18.67	7.16	3.856
5	18.70	7.21	3.843
6	18.94	7.30	3.814
7	19.24	7.53	3.751
8	20.42	8.60	3.488
9	20.59	8.75	3.455
10	24.80	15.83	2.494
11	29.63	21.45	2.111

COMPUTED CONFLUENCE ESTIMATES ARE AS FOLLOWS:

PEAK FLOW RATE(CFS) = 29.63 Tc(MIN.) = 21.45

TOTAL AREA(ACRES) = 16.6

FLOW PROCESS FROM NODE 27.10 TO NODE 27.10 IS CODE = 12

>>>>CLEAR MEMORY BANK # 1 <<<<<

FLOW PROCESS FROM NODE 27.10 TO NODE 28.00 IS CODE = 41

>>>>COMPUTE PIPE-FLOW TRAVEL TIME THRU SUBAREA<<<<<

>>>>USING USER-SPECIFIED PIPESIZE (EXISTING ELEMENT)<<<<<

REPRESENTATIVE SLOPE = 0.0040

FLOW LENGTH(FEET) = 71.25 MANNING'S N = 0.013

DEPTH OF FLOW IN 36.0 INCH PIPE IS 22.6 INCHES

PIPE-FLOW VELOCITY(FEET/SEC.) = 6.33

GIVEN PIPE DIAMETER(INCH) = 36.00 NUMBER OF PIPES = 1

PIPE-FLOW(CFS) = 29.63

PIPE TRAVEL TIME(MIN.) = 0.19 Tc(MIN.) = 21.64

LONGEST FLOWPATH FROM NODE 27.20 TO NODE 28.00 = 2735.53 FEET.

FLOW PROCESS FROM NODE 28.00 TO NODE 28.00 IS CODE = 10

>>>>MAIN-STREAM MEMORY COPIED ONTO MEMORY BANK # 1 <<<<<

FLOW PROCESS FROM NODE 28.00 TO NODE 28.00 IS CODE = 13

>>>>CLEAR THE MAIN-STREAM MEMORY<<<<<

FLOW PROCESS FROM NODE 29.00 TO NODE 30.00 IS CODE = 21

>>>>RATIONAL METHOD INITIAL SUBAREA ANALYSIS<<<<<

ASSUMED INITIAL SUBAREA UNIFORM
DEVELOPMENT IS APARTMENT

$TC = K * [(LENGTH^{**3}) / (ELEVATION CHANGE)]^{**.2}$

INITIAL SUBAREA FLOW-LENGTH(FEET) = 61.88

UPSTREAM ELEVATION(FEET) = 882.80

DOWNSTREAM ELEVATION(FEET) = 882.10

ELEVATION DIFFERENCE(FEET) = 0.70

$TC = 0.323 * [(61.88^{**3}) / (0.70)]^{**.2} = 4.118$

COMPUTED TIME OF CONCENTRATION INCREASED TO 5 MIN.

100 YEAR RAINFALL INTENSITY(INCH/HOUR) = 4.697

APARTMENT DEVELOPMENT RUNOFF COEFFICIENT = .8796

SOIL CLASSIFICATION IS "C"

SUBAREA RUNOFF(CFS) = 0.68

TOTAL AREA(ACRES) = 0.16 TOTAL RUNOFF(CFS) = 0.68

FLOW PROCESS FROM NODE 30.00 TO NODE 31.00 IS CODE = 41

>>>>COMPUTE PIPE-FLOW TRAVEL TIME THRU SUBAREA<<<<<

>>>>USING USER-SPECIFIED PIPESIZE (EXISTING ELEMENT)<<<<<

REPRESENTATIVE SLOPE = 0.0100

FLOW LENGTH(FEET) = 55.57 MANNING'S N = 0.009

ASSUME FULL-FLOWING PIPELINE

PIPE-FLOW VELOCITY(FEET/SEC.) = 7.76

PIPE FLOW VELOCITY = (TOTAL FLOW) / (PIPE CROSS SECTION AREA)

GIVEN PIPE DIAMETER(INCH) = 4.00 NUMBER OF PIPES = 1

PIPE-FLOW(CFS) = 0.68

PIPE TRAVEL TIME(MIN.) = 0.12 T_c (MIN.) = 5.12

LONGEST FLOWPATH FROM NODE 29.00 TO NODE 31.00 = 117.45 FEET.

FLOW PROCESS FROM NODE 31.00 TO NODE 32.00 IS CODE = 41

>>>>COMPUTE PIPE-FLOW TRAVEL TIME THRU SUBAREA<<<<<

>>>>USING USER-SPECIFIED PIPESIZE (EXISTING ELEMENT)<<<<<

REPRESENTATIVE SLOPE = 0.0100

FLOW LENGTH(FEET) = 89.09 MANNING'S N = 0.009

DEPTH OF FLOW IN 6.0 INCH PIPE IS 4.3 INCHES

PIPE-FLOW VELOCITY(FEET/SEC.) = 4.51

GIVEN PIPE DIAMETER(INCH) = 6.00 NUMBER OF PIPES = 1

PIPE-FLOW(CFS) = 0.68
PIPE TRAVEL TIME(MIN.) = 0.33 Tc(MIN.) = 5.45
LONGEST FLOWPATH FROM NODE 29.00 TO NODE 32.00 = 206.54 FEET.

FLOW PROCESS FROM NODE 32.00 TO NODE 33.00 IS CODE = 41

>>>>COMPUTE PIPE-FLOW TRAVEL TIME THRU SUBAREA<<<<<
>>>>USING USER-SPECIFIED PIPESIZE (EXISTING ELEMENT)<<<<<

=====

REPRESENTATIVE SLOPE = 0.0100
FLOW LENGTH(FEET) = 23.50 MANNING'S N = 0.009
DEPTH OF FLOW IN 8.0 INCH PIPE IS 3.5 INCHES
PIPE-FLOW VELOCITY(FEET/SEC.) = 4.58
GIVEN PIPE DIAMETER(INCH) = 8.00 NUMBER OF PIPES = 1
PIPE-FLOW(CFS) = 0.68
PIPE TRAVEL TIME(MIN.) = 0.09 Tc(MIN.) = 5.53
LONGEST FLOWPATH FROM NODE 29.00 TO NODE 33.00 = 230.04 FEET.

FLOW PROCESS FROM NODE 33.00 TO NODE 33.00 IS CODE = 10

>>>>MAIN-STREAM MEMORY COPIED ONTO MEMORY BANK # 3 <<<<<

FLOW PROCESS FROM NODE 33.00 TO NODE 33.00 IS CODE = 13

>>>>CLEAR THE MAIN-STREAM MEMORY<<<<<

FLOW PROCESS FROM NODE 34.00 TO NODE 35.00 IS CODE = 21

>>>>RATIONAL METHOD INITIAL SUBAREA ANALYSIS<<<<<

=====

ASSUMED INITIAL SUBAREA UNIFORM
DEVELOPMENT IS APARTMENT
TC = K*[(LENGTH**3)/(ELEVATION CHANGE)]**.2
INITIAL SUBAREA FLOW-LENGTH(FEET) = 65.92
UPSTREAM ELEVATION(FEET) = 15.00
DOWNSTREAM ELEVATION(FEET) = 13.00
ELEVATION DIFFERENCE(FEET) = 2.00
TC = 0.323*[(65.92**3)/(2.00)]**.2 = 3.467
COMPUTED TIME OF CONCENTRATION INCREASED TO 5 MIN.
100 YEAR RAINFALL INTENSITY(INCH/HOUR) = 4.697
APARTMENT DEVELOPMENT RUNOFF COEFFICIENT = .8796
SOIL CLASSIFICATION IS "C"
SUBAREA RUNOFF(CFS) = 0.38
TOTAL AREA(ACRES) = 0.09 TOTAL RUNOFF(CFS) = 0.38

FLOW PROCESS FROM NODE 35.00 TO NODE 33.00 IS CODE = 41

>>>>COMPUTE PIPE-FLOW TRAVEL TIME THRU SUBAREA<<<<<
>>>>USING USER-SPECIFIED PIPESIZE (EXISTING ELEMENT)<<<<<

=====

REPRESENTATIVE SLOPE =	0.0100		
FLOW LENGTH(FEET) =	2.00	MANNING'S N =	0.009
ASSUME FULL-FLOWING PIPELINE			
PIPE-FLOW VELOCITY(FEET/SEC.) =	4.40		
PIPE FLOW VELOCITY = (TOTAL FLOW)/(PIPE CROSS SECTION AREA)			
GIVEN PIPE DIAMETER(INCH) =	4.00	NUMBER OF PIPES =	1
PIPE-FLOW(CFS) =	0.38		
PIPE TRAVEL TIME(MIN.) =	0.01	Tc(MIN.) =	5.01
LONGEST FLOWPATH FROM NODE 34.00 TO NODE 33.00 =			67.92 FEET.

FLOW PROCESS FROM NODE 33.00 TO NODE 33.00 IS CODE = 11

>>>>CONFLUENCE MEMORY BANK # 3 WITH THE MAIN-STREAM MEMORY<<<<<

=====

** MAIN STREAM CONFLUENCE DATA **

STREAM NUMBER	RUNOFF (CFS)	Tc (MIN.)	INTENSITY (INCH/HOUR)	AREA (ACRE)
1	0.38	5.01	4.693	0.09
LONGEST FLOWPATH FROM NODE 34.00 TO NODE 33.00 =				67.92 FEET.

** MEMORY BANK # 3 CONFLUENCE DATA **

STREAM NUMBER	RUNOFF (CFS)	Tc (MIN.)	INTENSITY (INCH/HOUR)	AREA (ACRE)
1	0.68	5.53	4.442	0.16
LONGEST FLOWPATH FROM NODE 29.00 TO NODE 33.00 =				230.04 FEET.

** PEAK FLOW RATE TABLE **

STREAM NUMBER	RUNOFF (CFS)	Tc (MIN.)	INTENSITY (INCH/HOUR)
1	1.00	5.01	4.693
2	1.04	5.53	4.442

COMPUTED CONFLUENCE ESTIMATES ARE AS FOLLOWS:

PEAK FLOW RATE(CFS) = 1.04 Tc(MIN.) = 5.53
TOTAL AREA(ACRES) = 0.3

FLOW PROCESS FROM NODE 33.00 TO NODE 33.00 IS CODE = 12

>>>>CLEAR MEMORY BANK # 3 <<<<<

=====

FLOW PROCESS FROM NODE 33.00 TO NODE 36.00 IS CODE = 41

>>>>COMPUTE PIPE-FLOW TRAVEL TIME THRU SUBAREA<<<<<
>>>>USING USER-SPECIFIED PIPESIZE (EXISTING ELEMENT)<<<<<

=====

REPRESENTATIVE SLOPE =	0.0100		
FLOW LENGTH(FEET) =	48.57	MANNING'S N =	0.009
DEPTH OF FLOW IN	8.0 INCH PIPE IS	4.5 INCHES	
PIPE-FLOW VELOCITY(FEET/SEC.) =	5.11		
GIVEN PIPE DIAMETER(INCH) =	8.00	NUMBER OF PIPES =	1
PIPE-FLOW(CFS) =	1.04		
PIPE TRAVEL TIME(MIN.) =	0.16	Tc(MIN.) =	5.69
LONGEST FLOWPATH FROM NODE	29.00 TO NODE	36.00 =	278.61 FEET.

FLOW PROCESS FROM NODE 36.00 TO NODE 36.00 IS CODE = 10

>>>>MAIN-STREAM MEMORY COPIED ONTO MEMORY BANK # 3<<<<<

FLOW PROCESS FROM NODE 34.00 TO NODE 34.00 IS CODE = 13

>>>>CLEAR THE MAIN-STREAM MEMORY<<<<<

FLOW PROCESS FROM NODE 37.00 TO NODE 38.00 IS CODE = 21

>>>>RATIONAL METHOD INITIAL SUBAREA ANALYSIS<<<<<

=====

ASSUMED INITIAL SUBAREA UNIFORM
DEVELOPMENT IS: UNDEVELOPED WITH GOOD COVER

$TC = K * [(LENGTH^{**3}) / (ELEVATION CHANGE)]^{**0.2}$

INITIAL SUBAREA FLOW-LENGTH(FEET) =	47.00		
UPSTREAM ELEVATION(FEET) =	879.59		
DOWNSTREAM ELEVATION(FEET) =	878.75		
ELEVATION DIFFERENCE(FEET) =	0.84		
$TC = 0.937 * [(47.00^{**3}) / (0.84)]^{**0.2} =$	9.780		
100 YEAR RAINFALL INTENSITY(INCH/HOUR) =	3.250		
UNDEVELOPED WATERSHED RUNOFF COEFFICIENT =	.7599		
SOIL CLASSIFICATION IS	"C"		
SUBAREA RUNOFF(CFS) =	0.22		
TOTAL AREA(ACRES) =	0.09	TOTAL RUNOFF(CFS) =	0.22

FLOW PROCESS FROM NODE 38.00 TO NODE 36.00 IS CODE = 41

>>>>COMPUTE PIPE-FLOW TRAVEL TIME THRU SUBAREA<<<<<
>>>>USING USER-SPECIFIED PIPESIZE (EXISTING ELEMENT)<<<<<

=====

REPRESENTATIVE SLOPE = 0.0100
FLOW LENGTH(FEET) = 14.50 MANNING'S N = 0.009
DEPTH OF FLOW IN 10.0 INCH PIPE IS 1.8 INCHES
PIPE-FLOW VELOCITY(FEET/SEC.) = 3.25
GIVEN PIPE DIAMETER(INCH) = 10.00 NUMBER OF PIPES = 1
PIPE-FLOW(CFS) = 0.22
PIPE TRAVEL TIME(MIN.) = 0.07 Tc(MIN.) = 9.85
LONGEST FLOWPATH FROM NODE 37.00 TO NODE 36.00 = 61.50 FEET.

FLOW PROCESS FROM NODE 36.00 TO NODE 36.00 IS CODE = 11

>>>>CONFLUENCE MEMORY BANK # 3 WITH THE MAIN-STREAM MEMORY<<<<<

=====

** MAIN STREAM CONFLUENCE DATA **

STREAM NUMBER	RUNOFF (CFS)	Tc (MIN.)	INTENSITY (INCH/HOUR)	AREA (ACRE)
1	0.22	9.85	3.236	0.09

LONGEST FLOWPATH FROM NODE 37.00 TO NODE 36.00 = 61.50 FEET.

** MEMORY BANK # 3 CONFLUENCE DATA **

STREAM NUMBER	RUNOFF (CFS)	Tc (MIN.)	INTENSITY (INCH/HOUR)	AREA (ACRE)
1	1.00	5.17	4.613	0.26
2	1.04	5.69	4.374	0.26

LONGEST FLOWPATH FROM NODE 29.00 TO NODE 36.00 = 278.61 FEET.

** PEAK FLOW RATE TABLE **

STREAM NUMBER	RUNOFF (CFS)	Tc (MIN.)	INTENSITY (INCH/HOUR)
1	1.11	5.17	4.613
2	1.17	5.69	4.374
3	0.99	9.85	3.236

COMPUTED CONFLUENCE ESTIMATES ARE AS FOLLOWS:

PEAK FLOW RATE(CFS) = 1.17 Tc(MIN.) = 5.69
TOTAL AREA(ACRES) = 0.3

FLOW PROCESS FROM NODE 36.00 TO NODE 39.00 IS CODE = 41

>>>>COMPUTE PIPE-FLOW TRAVEL TIME THRU SUBAREA<<<<<
>>>>USING USER-SPECIFIED PIPESIZE (EXISTING ELEMENT)<<<<<

=====

REPRESENTATIVE SLOPE = 0.0100
FLOW LENGTH(FEET) = 52.84 MANNING'S N = 0.009

DEPTH OF FLOW IN 10.0 INCH PIPE IS 4.3 INCHES
PIPE-FLOW VELOCITY(FEET/SEC.) = 5.27
GIVEN PIPE DIAMETER(INCH) = 10.00 NUMBER OF PIPES = 1
PIPE-FLOW(CFS) = 1.17
PIPE TRAVEL TIME(MIN.) = 0.17 Tc(MIN.) = 5.86
LONGEST FLOWPATH FROM NODE 29.00 TO NODE 39.00 = 331.45 FEET.

FLOW PROCESS FROM NODE 39.00 TO NODE 39.00 IS CODE = 10

>>>>MAIN-STREAM MEMORY COPIED ONTO MEMORY BANK # 3 <<<<<

=====
***MEMORY BANK # 3 IS FULL. THEREFORE, MAIN-STREAM MEMORY
DATA CAN NOT BE COPIED ONTO IT - PROCESS IGNORED.***

FLOW PROCESS FROM NODE 39.00 TO NODE 39.00 IS CODE = 13

>>>>CLEAR THE MAIN-STREAM MEMORY<<<<<

FLOW PROCESS FROM NODE 40.00 TO NODE 41.00 IS CODE = 21

>>>>RATIONAL METHOD INITIAL SUBAREA ANALYSIS<<<<<

=====
ASSUMED INITIAL SUBAREA UNIFORM
DEVELOPMENT IS APARTMENT
TC = K*[(LENGTH**3)/(ELEVATION CHANGE)]**.2
INITIAL SUBAREA FLOW-LENGTH(FEET) = 74.92
UPSTREAM ELEVATION(FEET) = 15.00
DOWNSTREAM ELEVATION(FEET) = 13.00
ELEVATION DIFFERENCE(FEET) = 2.00
TC = 0.323*[(74.92**3)/(2.00)]**.2 = 3.744
COMPUTED TIME OF CONCENTRATION INCREASED TO 5 MIN.
100 YEAR RAINFALL INTENSITY(INCH/HOUR) = 4.697
APARTMENT DEVELOPMENT RUNOFF COEFFICIENT = .8796
SOIL CLASSIFICATION IS "C"
SUBAREA RUNOFF(CFS) = 1.67
TOTAL AREA(ACRES) = 0.40 TOTAL RUNOFF(CFS) = 1.67

FLOW PROCESS FROM NODE 41.00 TO NODE 39.00 IS CODE = 41

>>>>COMPUTE PIPE-FLOW TRAVEL TIME THRU SUBAREA<<<<<
>>>>USING USER-SPECIFIED PIPESIZE (EXISTING ELEMENT)<<<<<

=====
REPRESENTATIVE SLOPE = 0.0100
FLOW LENGTH(FEET) = 7.00 MANNING'S N = 0.009
ASSUME FULL-FLOWING PIPELINE

PIPE-FLOW VELOCITY(FEET/SEC.) = 19.13
 PIPE FLOW VELOCITY = (TOTAL FLOW)/(PIPE CROSS SECTION AREA)
 GIVEN PIPE DIAMETER(INCH) = 4.00 NUMBER OF PIPES = 1
 PIPE-FLOW(CFS) = 1.67
 PIPE TRAVEL TIME(MIN.) = 0.01 Tc(MIN.) = 5.01
 LONGEST FLOWPATH FROM NODE 40.00 TO NODE 39.00 = 81.92 FEET.

 FLOW PROCESS FROM NODE 39.00 TO NODE 39.00 IS CODE = 11

>>>>CONFLUENCE MEMORY BANK # 3 WITH THE MAIN-STREAM MEMORY<<<<<

** MAIN STREAM CONFLUENCE DATA **

STREAM NUMBER	RUNOFF (CFS)	Tc (MIN.)	INTENSITY (INCH/HOUR)	AREA (ACRE)
1	1.67	5.01	4.694	0.40

LONGEST FLOWPATH FROM NODE 40.00 TO NODE 39.00 = 81.92 FEET.

** MEMORY BANK # 3 CONFLUENCE DATA **

STREAM NUMBER	RUNOFF (CFS)	Tc (MIN.)	INTENSITY (INCH/HOUR)	AREA (ACRE)
1	1.00	5.17	4.613	0.26
2	1.04	5.69	4.374	0.26

LONGEST FLOWPATH FROM NODE 29.00 TO NODE 39.00 = 278.61 FEET.

** PEAK FLOW RATE TABLE **

STREAM NUMBER	RUNOFF (CFS)	Tc (MIN.)	INTENSITY (INCH/HOUR)
1	2.64	5.01	4.694
2	2.64	5.17	4.613
3	2.60	5.69	4.374

COMPUTED CONFLUENCE ESTIMATES ARE AS FOLLOWS:

PEAK FLOW RATE(CFS) = 2.64 Tc(MIN.) = 5.17
 TOTAL AREA(ACRES) = 0.7

 FLOW PROCESS FROM NODE 39.00 TO NODE 39.00 IS CODE = 12

>>>>CLEAR MEMORY BANK # 3 <<<<<

 FLOW PROCESS FROM NODE 39.00 TO NODE 42.00 IS CODE = 41

>>>>COMPUTE PIPE-FLOW TRAVEL TIME THRU SUBAREA<<<<<
 >>>>USING USER-SPECIFIED PIPESIZE (EXISTING ELEMENT)<<<<<

REPRESENTATIVE SLOPE = 0.0100

FLOW LENGTH(FEET) = 52.87 MANNING'S N = 0.009
DEPTH OF FLOW IN 10.0 INCH PIPE IS 7.1 INCHES
PIPE-FLOW VELOCITY(FEET/SEC.) = 6.35
GIVEN PIPE DIAMETER(INCH) = 10.00 NUMBER OF PIPES = 1
PIPE-FLOW(CFS) = 2.64
PIPE TRAVEL TIME(MIN.) = 0.14 Tc(MIN.) = 5.31
LONGEST FLOWPATH FROM NODE 29.00 TO NODE 42.00 = 331.48 FEET.

FLOW PROCESS FROM NODE 42.00 TO NODE 43.00 IS CODE = 41

>>>>COMPUTE PIPE-FLOW TRAVEL TIME THRU SUBAREA<<<<<
>>>>USING USER-SPECIFIED PIPESIZE (EXISTING ELEMENT)<<<<<

=====

REPRESENTATIVE SLOPE = 0.0100
FLOW LENGTH(FEET) = 91.61 MANNING'S N = 0.010
DEPTH OF FLOW IN 12.0 INCH PIPE IS 6.6 INCHES
PIPE-FLOW VELOCITY(FEET/SEC.) = 5.97
GIVEN PIPE DIAMETER(INCH) = 12.00 NUMBER OF PIPES = 1
PIPE-FLOW(CFS) = 2.64
PIPE TRAVEL TIME(MIN.) = 0.26 Tc(MIN.) = 5.56
LONGEST FLOWPATH FROM NODE 29.00 TO NODE 43.00 = 423.09 FEET.

FLOW PROCESS FROM NODE 43.00 TO NODE 43.00 IS CODE = 10

>>>>MAIN-STREAM MEMORY COPIED ONTO MEMORY BANK # 3 <<<<<

FLOW PROCESS FROM NODE 43.00 TO NODE 43.00 IS CODE = 13

>>>>CLEAR THE MAIN-STREAM MEMORY<<<<<

FLOW PROCESS FROM NODE 44.00 TO NODE 45.00 IS CODE = 21

>>>>RATIONAL METHOD INITIAL SUBAREA ANALYSIS<<<<<

=====

ASSUMED INITIAL SUBAREA UNIFORM
DEVELOPMENT IS APARTMENT
 $TC = K * [(LENGTH^{**3}) / (ELEVATION CHANGE)]^{**0.2}$
INITIAL SUBAREA FLOW-LENGTH(FEET) = 47.00
UPSTREAM ELEVATION(FEET) = 15.00
DOWNSTREAM ELEVATION(FEET) = 13.00
ELEVATION DIFFERENCE(FEET) = 2.00
 $TC = 0.323 * [(47.00^{**3}) / (2.00)]^{**0.2} = 2.830$
COMPUTED TIME OF CONCENTRATION INCREASED TO 5 MIN.
100 YEAR RAINFALL INTENSITY(INCH/HOUR) = 4.697

APARTMENT DEVELOPMENT RUNOFF COEFFICIENT = .8796
SOIL CLASSIFICATION IS "C"
SUBAREA RUNOFF(CFS) = 1.46
TOTAL AREA(ACRES) = 0.35 TOTAL RUNOFF(CFS) = 1.46

FLOW PROCESS FROM NODE 45.00 TO NODE 46.00 IS CODE = 41

>>>>COMPUTE PIPE-FLOW TRAVEL TIME THRU SUBAREA<<<<<
>>>>USING USER-SPECIFIED PIPESIZE (EXISTING ELEMENT)<<<<<

=====

REPRESENTATIVE SLOPE = 0.0100
FLOW LENGTH(FEET) = 32.65 MANNING'S N = 0.009
ASSUME FULL-FLOWING PIPELINE
PIPE-FLOW VELOCITY(FEET/SEC.) = 7.43
PIPE FLOW VELOCITY = (TOTAL FLOW)/(PIPE CROSS SECTION AREA)
GIVEN PIPE DIAMETER(INCH) = 6.00 NUMBER OF PIPES = 1
PIPE-FLOW(CFS) = 1.46
PIPE TRAVEL TIME(MIN.) = 0.07 Tc(MIN.) = 5.07
LONGEST FLOWPATH FROM NODE 44.00 TO NODE 46.00 = 79.65 FEET.

FLOW PROCESS FROM NODE 46.00 TO NODE 47.00 IS CODE = 41

>>>>COMPUTE PIPE-FLOW TRAVEL TIME THRU SUBAREA<<<<<
>>>>USING USER-SPECIFIED PIPESIZE (EXISTING ELEMENT)<<<<<

=====

REPRESENTATIVE SLOPE = 0.0100
FLOW LENGTH(FEET) = 231.00 MANNING'S N = 0.009
DEPTH OF FLOW IN 8.0 INCH PIPE IS 5.7 INCHES
PIPE-FLOW VELOCITY(FEET/SEC.) = 5.49
GIVEN PIPE DIAMETER(INCH) = 8.00 NUMBER OF PIPES = 1
PIPE-FLOW(CFS) = 1.46
PIPE TRAVEL TIME(MIN.) = 0.70 Tc(MIN.) = 5.77
LONGEST FLOWPATH FROM NODE 44.00 TO NODE 47.00 = 310.65 FEET.

FLOW PROCESS FROM NODE 47.00 TO NODE 47.00 IS CODE = 81

>>>>ADDITION OF SUBAREA TO MAINLINE PEAK FLOW<<<<<

=====

100 YEAR RAINFALL INTENSITY(INCH/HOUR) = 4.340
APARTMENT DEVELOPMENT RUNOFF COEFFICIENT = .8782
SOIL CLASSIFICATION IS "C"
SUBAREA AREA(ACRES) = 0.22 SUBAREA RUNOFF(CFS) = 0.85
TOTAL AREA(ACRES) = 0.6 TOTAL RUNOFF(CFS) = 2.31
TC(MIN.) = 5.77

FLOW PROCESS FROM NODE 47.00 TO NODE 48.00 IS CODE = 41

>>>>COMPUTE PIPE-FLOW TRAVEL TIME THRU SUBAREA<<<<<
>>>>USING USER-SPECIFIED PIPESIZE (EXISTING ELEMENT)<<<<<

=====

REPRESENTATIVE SLOPE = 0.0100
FLOW LENGTH(FEET) = 40.21 MANNING'S N = 0.009
ASSUME FULL-FLOWING PIPELINE
PIPE-FLOW VELOCITY(FEET/SEC.) = 6.61
PIPE FLOW VELOCITY = (TOTAL FLOW)/(PIPE CROSS SECTION AREA)
GIVEN PIPE DIAMETER(INCH) = 8.00 NUMBER OF PIPES = 1
PIPE-FLOW(CFS) = 2.31
PIPE TRAVEL TIME(MIN.) = 0.10 Tc(MIN.) = 5.88
LONGEST FLOWPATH FROM NODE 44.00 TO NODE 48.00 = 350.86 FEET.

FLOW PROCESS FROM NODE 48.00 TO NODE 48.00 IS CODE = 81

>>>>ADDITION OF SUBAREA TO MAINLINE PEAK FLOW<<<<<

=====

100 YEAR RAINFALL INTENSITY(INCH/HOUR) = 4.298
APARTMENT DEVELOPMENT RUNOFF COEFFICIENT = .8780
SOIL CLASSIFICATION IS "C"
SUBAREA AREA(ACRES) = 0.29 SUBAREA RUNOFF(CFS) = 1.09
TOTAL AREA(ACRES) = 0.9 TOTAL RUNOFF(CFS) = 3.40
TC(MIN.) = 5.88

FLOW PROCESS FROM NODE 48.00 TO NODE 43.00 IS CODE = 41

>>>>COMPUTE PIPE-FLOW TRAVEL TIME THRU SUBAREA<<<<<
>>>>USING USER-SPECIFIED PIPESIZE (EXISTING ELEMENT)<<<<<

=====

REPRESENTATIVE SLOPE = 0.0100
FLOW LENGTH(FEET) = 98.04 MANNING'S N = 0.009
ASSUME FULL-FLOWING PIPELINE
PIPE-FLOW VELOCITY(FEET/SEC.) = 9.73
PIPE FLOW VELOCITY = (TOTAL FLOW)/(PIPE CROSS SECTION AREA)
GIVEN PIPE DIAMETER(INCH) = 8.00 NUMBER OF PIPES = 1
PIPE-FLOW(CFS) = 3.40
PIPE TRAVEL TIME(MIN.) = 0.17 Tc(MIN.) = 6.04
LONGEST FLOWPATH FROM NODE 44.00 TO NODE 43.00 = 448.90 FEET.

FLOW PROCESS FROM NODE 43.00 TO NODE 43.00 IS CODE = 11

>>>>CONFLUENCE MEMORY BANK # 3 WITH THE MAIN-STREAM MEMORY<<<<<

=====

** MAIN STREAM CONFLUENCE DATA **

STREAM	RUNOFF	Tc	INTENSITY	AREA
--------	--------	----	-----------	------

NUMBER	(CFS)	(MIN.)	(INCH/HOUR)	(ACRE)
1	3.40	6.04	4.232	0.86

LONGEST FLOWPATH FROM NODE 44.00 TO NODE 43.00 = 448.90 FEET.

** MEMORY BANK # 3 CONFLUENCE DATA **

STREAM NUMBER	RUNOFF (CFS)	Tc (MIN.)	INTENSITY (INCH/HOUR)	AREA (ACRE)
1	2.64	5.40	4.502	0.66
2	2.64	5.56	4.430	0.66
3	2.60	6.09	4.215	0.66

LONGEST FLOWPATH FROM NODE 29.00 TO NODE 43.00 = 423.09 FEET.

** PEAK FLOW RATE TABLE **

STREAM NUMBER	RUNOFF (CFS)	Tc (MIN.)	INTENSITY (INCH/HOUR)
1	5.67	5.40	4.502
2	5.76	5.56	4.430
3	5.97	6.04	4.232
4	5.98	6.09	4.215

COMPUTED CONFLUENCE ESTIMATES ARE AS FOLLOWS:

PEAK FLOW RATE(CFS) = 5.98 Tc(MIN.) = 6.09
 TOTAL AREA(ACRES) = 1.5

 FLOW PROCESS FROM NODE 43.00 TO NODE 43.00 IS CODE = 12

>>>>CLEAR MEMORY BANK # 3 <<<<<

 FLOW PROCESS FROM NODE 43.00 TO NODE 49.00 IS CODE = 41

>>>>COMPUTE PIPE-FLOW TRAVEL TIME THRU SUBAREA<<<<<
 >>>>USING USER-SPECIFIED PIPESIZE (EXISTING ELEMENT)<<<<<

REPRESENTATIVE SLOPE = 0.0100
 FLOW LENGTH(FEET) = 33.92 MANNING'S N = 0.010
 ASSUME FULL-FLOWING PIPELINE
 PIPE-FLOW VELOCITY(FEET/SEC.) = 7.61
 PIPE FLOW VELOCITY = (TOTAL FLOW)/(PIPE CROSS SECTION AREA)
 GIVEN PIPE DIAMETER(INCH) = 12.00 NUMBER OF PIPES = 1
 PIPE-FLOW(CFS) = 5.98
 PIPE TRAVEL TIME(MIN.) = 0.07 Tc(MIN.) = 6.16
 LONGEST FLOWPATH FROM NODE 44.00 TO NODE 49.00 = 482.82 FEET.

 FLOW PROCESS FROM NODE 49.00 TO NODE 49.00 IS CODE = 10

>>>>MAIN-STREAM MEMORY COPIED ONTO MEMORY BANK # 2 <<<<<

FLOW PROCESS FROM NODE 49.00 TO NODE 49.00 IS CODE = 13

>>>>CLEAR THE MAIN-STREAM MEMORY<<<<<

FLOW PROCESS FROM NODE 50.00 TO NODE 51.00 IS CODE = 21

>>>>RATIONAL METHOD INITIAL SUBAREA ANALYSIS<<<<<

ASSUMED INITIAL SUBAREA UNIFORM
DEVELOPMENT IS APARTMENT
TC = $K * [(LENGTH^{**3}) / (ELEVATION CHANGE)]^{**0.2}$
INITIAL SUBAREA FLOW-LENGTH(FEET) = 97.11
UPSTREAM ELEVATION(FEET) = 878.85
DOWNSTREAM ELEVATION(FEET) = 877.75
ELEVATION DIFFERENCE(FEET) = 1.10
TC = $0.323 * [(97.11^{**3}) / (1.10)]^{**0.2} = 4.930$
COMPUTED TIME OF CONCENTRATION INCREASED TO 5 MIN.
100 YEAR RAINFALL INTENSITY(INCH/HOUR) = 4.697
APARTMENT DEVELOPMENT RUNOFF COEFFICIENT = .8796
SOIL CLASSIFICATION IS "C"
SUBAREA RUNOFF(CFS) = 1.39
TOTAL AREA(ACRES) = 0.34 TOTAL RUNOFF(CFS) = 1.39

FLOW PROCESS FROM NODE 51.00 TO NODE 51.00 IS CODE = 11

>>>>CONFLUENCE MEMORY BANK # 2 WITH THE MAIN-STREAM MEMORY<<<<<

** MAIN STREAM CONFLUENCE DATA **
STREAM RUNOFF Tc INTENSITY AREA
NUMBER (CFS) (MIN.) (INCH/HOUR) (ACRE)
1 1.39 5.00 4.697 0.34
LONGEST FLOWPATH FROM NODE 50.00 TO NODE 51.00 = 97.11 FEET.

** MEMORY BANK # 2 CONFLUENCE DATA **
STREAM RUNOFF Tc INTENSITY AREA
NUMBER (CFS) (MIN.) (INCH/HOUR) (ACRE)
1 5.67 5.48 4.467 1.52
2 5.76 5.64 4.397 1.52
3 5.97 6.12 4.204 1.52
4 5.98 6.16 4.187 1.52
LONGEST FLOWPATH FROM NODE 44.00 TO NODE 51.00 = 482.82 FEET.

** PEAK FLOW RATE TABLE **

STREAM NUMBER	RUNOFF (CFS)	Tc (MIN.)	INTENSITY (INCH/HOUR)
1	6.57	5.00	4.697
2	6.99	5.48	4.467
3	7.07	5.64	4.397
4	7.22	6.12	4.204
5	7.22	6.16	4.187

COMPUTED CONFLUENCE ESTIMATES ARE AS FOLLOWS:

PEAK FLOW RATE(CFS) = 7.22 Tc(MIN.) = 6.16
TOTAL AREA(ACRES) = 1.9

```
*****
FLOW PROCESS FROM NODE      51.00 TO NODE      51.00 IS CODE = 12
-----
>>>>>CLEAR MEMORY BANK # 2 <<<<<
=====
```

```
*****
FLOW PROCESS FROM NODE      51.00 TO NODE      52.00 IS CODE = 41
-----
>>>>>COMPUTE PIPE-FLOW TRAVEL TIME THRU SUBAREA<<<<<
>>>>>USING USER-SPECIFIED PIPESIZE (EXISTING ELEMENT)<<<<<
=====
```

```
REPRESENTATIVE SLOPE = 0.0100
FLOW LENGTH(FEET) = 51.05 MANNING'S N = 0.010
DEPTH OF FLOW IN 15.0 INCH PIPE IS 10.9 INCHES
PIPE-FLOW VELOCITY(FEET/SEC.) = 7.53
GIVEN PIPE DIAMETER(INCH) = 15.00 NUMBER OF PIPES = 1
PIPE-FLOW(CFS) = 7.22
PIPE TRAVEL TIME(MIN.) = 0.11 Tc(MIN.) = 6.28
LONGEST FLOWPATH FROM NODE 44.00 TO NODE 52.00 = 533.87 FEET.
```

```
*****
FLOW PROCESS FROM NODE      52.00 TO NODE      52.00 IS CODE = 10
-----
>>>>>MAIN-STREAM MEMORY COPIED ONTO MEMORY BANK # 2 <<<<<
=====
```

```
*****
FLOW PROCESS FROM NODE      52.00 TO NODE      52.00 IS CODE = 13
-----
>>>>>CLEAR THE MAIN-STREAM MEMORY<<<<<
=====
```

```
*****
FLOW PROCESS FROM NODE      53.00 TO NODE      54.00 IS CODE = 21
-----
>>>>>RATIONAL METHOD INITIAL SUBAREA ANALYSIS<<<<<
=====
```

ASSUMED INITIAL SUBAREA UNIFORM
 DEVELOPMENT IS APARTMENT
 $TC = K * [(LENGTH^{**3}) / (ELEVATION CHANGE)]^{**0.2}$
 INITIAL SUBAREA FLOW-LENGTH(FEET) = 96.84
 UPSTREAM ELEVATION(FEET) = 878.85
 DOWNSTREAM ELEVATION(FEET) = 877.60
 ELEVATION DIFFERENCE(FEET) = 1.25
 $TC = 0.323 * [(96.84^{**3}) / (1.25)]^{**0.2} = 4.798$
 COMPUTED TIME OF CONCENTRATION INCREASED TO 5 MIN.
 100 YEAR RAINFALL INTENSITY(INCH/HOUR) = 4.697
 APARTMENT DEVELOPMENT RUNOFF COEFFICIENT = .8796
 SOIL CLASSIFICATION IS "C"
 SUBAREA RUNOFF(CFS) = 1.28
 TOTAL AREA(ACRES) = 0.31 TOTAL RUNOFF(CFS) = 1.28

 FLOW PROCESS FROM NODE 54.00 TO NODE 54.00 IS CODE = 10

>>>>MAIN-STREAM MEMORY COPIED ONTO MEMORY BANK # 3 <<<<<

 FLOW PROCESS FROM NODE 54.00 TO NODE 54.00 IS CODE = 13

>>>>CLEAR THE MAIN-STREAM MEMORY<<<<<

 FLOW PROCESS FROM NODE 55.00 TO NODE 56.00 IS CODE = 21

>>>>RATIONAL METHOD INITIAL SUBAREA ANALYSIS<<<<<

ASSUMED INITIAL SUBAREA UNIFORM
 DEVELOPMENT IS APARTMENT
 $TC = K * [(LENGTH^{**3}) / (ELEVATION CHANGE)]^{**0.2}$
 INITIAL SUBAREA FLOW-LENGTH(FEET) = 217.19
 UPSTREAM ELEVATION(FEET) = 881.21
 DOWNSTREAM ELEVATION(FEET) = 878.03
 ELEVATION DIFFERENCE(FEET) = 3.18
 $TC = 0.323 * [(217.19^{**3}) / (3.18)]^{**0.2} = 6.463$
 100 YEAR RAINFALL INTENSITY(INCH/HOUR) = 4.080
 APARTMENT DEVELOPMENT RUNOFF COEFFICIENT = .8770
 SOIL CLASSIFICATION IS "C"
 SUBAREA RUNOFF(CFS) = 4.00
 TOTAL AREA(ACRES) = 1.12 TOTAL RUNOFF(CFS) = 4.00

 FLOW PROCESS FROM NODE 56.00 TO NODE 57.00 IS CODE = 41

>>>>COMPUTE PIPE-FLOW TRAVEL TIME THRU SUBAREA<<<<<

>>>>USING USER-SPECIFIED PIPESIZE (EXISTING ELEMENT)<<<<<

=====

REPRESENTATIVE SLOPE = 0.0100
FLOW LENGTH(FEET) = 140.51 MANNING'S N = 0.009
ASSUME FULL-FLOWING PIPELINE
PIPE-FLOW VELOCITY(FEET/SEC.) = 11.45
PIPE FLOW VELOCITY = (TOTAL FLOW)/(PIPE CROSS SECTION AREA)
GIVEN PIPE DIAMETER(INCH) = 8.00 NUMBER OF PIPES = 1
PIPE-FLOW(CFS) = 4.00
PIPE TRAVEL TIME(MIN.) = 0.20 Tc(MIN.) = 6.67
LONGEST FLOWPATH FROM NODE 55.00 TO NODE 57.00 = 357.70 FEET.

FLOW PROCESS FROM NODE 57.00 TO NODE 57.00 IS CODE = 11

>>>>CONFLUENCE MEMORY BANK # 3 WITH THE MAIN-STREAM MEMORY<<<<<

=====

** MAIN STREAM CONFLUENCE DATA **

STREAM NUMBER	RUNOFF (CFS)	Tc (MIN.)	INTENSITY (INCH/HOUR)	AREA (ACRE)
1	4.00	6.67	4.010	1.12

LONGEST FLOWPATH FROM NODE 55.00 TO NODE 57.00 = 357.70 FEET.

** MEMORY BANK # 3 CONFLUENCE DATA **

STREAM NUMBER	RUNOFF (CFS)	Tc (MIN.)	INTENSITY (INCH/HOUR)	AREA (ACRE)
1	1.28	5.00	4.697	0.31

LONGEST FLOWPATH FROM NODE 53.00 TO NODE 57.00 = 96.84 FEET.

** PEAK FLOW RATE TABLE **

STREAM NUMBER	RUNOFF (CFS)	Tc (MIN.)	INTENSITY (INCH/HOUR)
1	4.28	5.00	4.697
2	5.09	6.67	4.010

COMPUTED CONFLUENCE ESTIMATES ARE AS FOLLOWS:

PEAK FLOW RATE(CFS) = 5.09 Tc(MIN.) = 6.67
TOTAL AREA(ACRES) = 1.4

FLOW PROCESS FROM NODE 57.00 TO NODE 57.00 IS CODE = 11

>>>>CONFLUENCE MEMORY BANK # 2 WITH THE MAIN-STREAM MEMORY<<<<<

=====

** MAIN STREAM CONFLUENCE DATA **

STREAM NUMBER	RUNOFF (CFS)	Tc (MIN.)	INTENSITY (INCH/HOUR)	AREA (ACRE)
1	4.28	5.00	4.697	1.43

2 5.09 6.67 4.010 1.43
LONGEST FLOWPATH FROM NODE 55.00 TO NODE 57.00 = 357.70 FEET.

** MEMORY BANK # 2 CONFLUENCE DATA **

STREAM NUMBER	RUNOFF (CFS)	Tc (MIN.)	INTENSITY (INCH/HOUR)	AREA (ACRE)
1	6.57	5.11	4.639	1.86
2	6.99	5.59	4.417	1.86
3	7.07	5.75	4.349	1.86
4	7.22	6.23	4.162	1.86
5	7.22	6.28	4.146	1.86

LONGEST FLOWPATH FROM NODE 44.00 TO NODE 57.00 = 533.87 FEET.

** PEAK FLOW RATE TABLE **

STREAM NUMBER	RUNOFF (CFS)	Tc (MIN.)	INTENSITY (INCH/HOUR)
1	10.70	5.00	4.697
2	10.79	5.11	4.639
3	11.26	5.59	4.417
4	11.46	5.75	4.349
5	11.98	6.23	4.162
6	12.01	6.28	4.146
7	12.07	6.67	4.010

COMPUTED CONFLUENCE ESTIMATES ARE AS FOLLOWS:

PEAK FLOW RATE(CFS) = 12.07 Tc(MIN.) = 6.67
TOTAL AREA(ACRES) = 3.3

FLOW PROCESS FROM NODE 57.00 TO NODE 57.00 IS CODE = 12

>>>>>CLEAR MEMORY BANK # 2 <<<<<<
=====

FLOW PROCESS FROM NODE 57.00 TO NODE 57.00 IS CODE = 12

>>>>>CLEAR MEMORY BANK # 3 <<<<<<
=====

FLOW PROCESS FROM NODE 57.00 TO NODE 58.00 IS CODE = 41

>>>>>COMPUTE PIPE-FLOW TRAVEL TIME THRU SUBAREA<<<<<<
>>>>>USING USER-SPECIFIED PIPESIZE (EXISTING ELEMENT)<<<<<<
=====

REPRESENTATIVE SLOPE = 0.0100
FLOW LENGTH(FEET) = 77.27 MANNING'S N = 0.010
DEPTH OF FLOW IN 18.0 INCH PIPE IS 13.4 INCHES
PIPE-FLOW VELOCITY(FEET/SEC.) = 8.53

GIVEN PIPE DIAMETER(INCH) = 18.00 NUMBER OF PIPES = 1
 PIPE-FLOW(CFS) = 12.07
 PIPE TRAVEL TIME(MIN.) = 0.15 Tc(MIN.) = 6.82
 LONGEST FLOWPATH FROM NODE 44.00 TO NODE 58.00 = 611.14 FEET.

FLOW PROCESS FROM NODE 58.00 TO NODE 58.00 IS CODE = 11

 >>>>CONFLUENCE MEMORY BANK # 1 WITH THE MAIN-STREAM MEMORY<<<<<
 =====

** MAIN STREAM CONFLUENCE DATA **

STREAM NUMBER	RUNOFF (CFS)	Tc (MIN.)	INTENSITY (INCH/HOUR)	AREA (ACRE)
1	10.70	5.15	4.619	3.29
2	10.79	5.27	4.564	3.29
3	11.26	5.74	4.352	3.29
4	11.46	5.90	4.287	3.29
5	11.98	6.38	4.108	3.29
6	12.01	6.43	4.092	3.29
7	12.07	6.82	3.961	3.29

LONGEST FLOWPATH FROM NODE 44.00 TO NODE 58.00 = 611.14 FEET.

** MEMORY BANK # 1 CONFLUENCE DATA **

STREAM NUMBER	RUNOFF (CFS)	Tc (MIN.)	INTENSITY (INCH/HOUR)	AREA (ACRE)
1	17.41	6.97	3.912	16.59
2	18.00	7.14	3.863	16.59
3	18.54	7.32	3.809	16.59
4	18.67	7.37	3.795	16.59
5	18.70	7.41	3.783	16.59
6	18.94	7.51	3.756	16.59
7	19.24	7.74	3.695	16.59
8	20.42	8.80	3.443	16.59
9	20.59	8.95	3.412	16.59
10	24.80	16.02	2.478	16.59
11	29.63	21.64	2.101	16.59

LONGEST FLOWPATH FROM NODE 27.20 TO NODE 58.00 = 2735.53 FEET.

** PEAK FLOW RATE TABLE **

STREAM NUMBER	RUNOFF (CFS)	Tc (MIN.)	INTENSITY (INCH/HOUR)
1	23.75	5.15	4.619
2	24.13	5.27	4.564
3	25.81	5.74	4.352
4	26.41	5.90	4.287
5	28.14	6.38	4.108
6	28.29	6.43	4.092
7	29.34	6.82	3.961
8	29.33	6.97	3.912

9	29.77	7.14	3.863
10	30.15	7.32	3.809
11	30.24	7.37	3.795
12	30.23	7.41	3.783
13	30.39	7.51	3.756
14	30.51	7.74	3.695
15	30.91	8.80	3.443
16	30.99	8.95	3.412
17	32.35	16.02	2.478
18	36.04	21.64	2.101

COMPUTED CONFLUENCE ESTIMATES ARE AS FOLLOWS:

PEAK FLOW RATE(CFS) = 36.04 Tc(MIN.) = 21.64
TOTAL AREA(ACRES) = 19.9

FLOW PROCESS FROM NODE 58.00 TO NODE 58.00 IS CODE = 12

>>>>CLEAR MEMORY BANK # 1 <<<<<

FLOW PROCESS FROM NODE 58.00 TO NODE 59.00 IS CODE = 41

>>>>COMPUTE PIPE-FLOW TRAVEL TIME THRU SUBAREA<<<<<

>>>>USING USER-SPECIFIED PIPESIZE (EXISTING ELEMENT)<<<<<

REPRESENTATIVE SLOPE = 0.0040
FLOW LENGTH(FEET) = 109.46 MANNING'S N = 0.013
DEPTH OF FLOW IN 36.0 INCH PIPE IS 26.1 INCHES
PIPE-FLOW VELOCITY(FEET/SEC.) = 6.56
GIVEN PIPE DIAMETER(INCH) = 36.00 NUMBER OF PIPES = 1
PIPE-FLOW(CFS) = 36.04
PIPE TRAVEL TIME(MIN.) = 0.28 Tc(MIN.) = 21.92
LONGEST FLOWPATH FROM NODE 27.20 TO NODE 59.00 = 2844.99 FEET.

END OF STUDY SUMMARY:

TOTAL AREA(ACRES) = 19.9 TC(MIN.) = 21.92

PEAK FLOW RATE(CFS) = 36.04

*** PEAK FLOW RATE TABLE ***

	Q(CFS)	Tc(MIN.)
1	23.75	5.46
2	24.13	5.57
3	25.81	6.04
4	26.41	6.20
5	28.14	6.67
6	28.29	6.72
7	29.34	7.11
8	29.33	7.26
9	29.77	7.43

10	30.15	7.61
11	30.24	7.66
12	30.23	7.70
13	30.39	7.80
14	30.51	8.03
15	30.91	9.09
16	30.99	9.24
17	32.35	16.31
18	36.04	21.92

=====
=====

END OF RATIONAL METHOD ANALYSIS



RATIONAL METHOD HYDROLOGY COMPUTER PROGRAM BASED ON
RIVERSIDE COUNTY FLOOD CONTROL & WATER CONSERVATION DISTRICT
(RCFC&WCD) 1978 HYDROLOGY MANUAL
(c) Copyright 1982-2016 Advanced Engineering Software (aes)
(Rational Tabling Version 23.0)
Release Date: 07/01/2016 License ID 1681

Analysis prepared by:

KHR Associates
17530 Von Karman Avenue
Irvine, CA 92626

***** DESCRIPTION OF STUDY *****

- * IRON LOFTS *
 - * POST-DEVELOPMENT HYDROLOGY - 6TH STREET RUNOFF NORTHERN HALF *
 - * 10-YEAR STORM EVENT *
- *****

FILE NAME: 6TH-STU.DAT
TIME/DATE OF STUDY: 15:24 07/26/2024

USER SPECIFIED HYDROLOGY AND HYDRAULIC MODEL INFORMATION:

USER SPECIFIED STORM EVENT(YEAR) = 10.00
 SPECIFIED MINIMUM PIPE SIZE(INCH) = 4.00
 SPECIFIED PERCENT OF GRADIENTS(DECIMAL) TO USE FOR FRICTION SLOPE = 0.95
 10-YEAR STORM 10-MINUTE INTENSITY(INCH/HOUR) = 2.140
 10-YEAR STORM 60-MINUTE INTENSITY(INCH/HOUR) = 0.800
 100-YEAR STORM 10-MINUTE INTENSITY(INCH/HOUR) = 3.210
 100-YEAR STORM 60-MINUTE INTENSITY(INCH/HOUR) = 1.200
 SLOPE OF 10-YEAR INTENSITY-DURATION CURVE = 0.5491525
 SLOPE OF 100-YEAR INTENSITY-DURATION CURVE = 0.5491524
 COMPUTED RAINFALL INTENSITY DATA:
 STORM EVENT = 10.00 1-HOUR INTENSITY(INCH/HOUR) = 0.808
 SLOPE OF INTENSITY DURATION CURVE = 0.5492
 RCFC&WCD HYDROLOGY MANUAL "C"-VALUES USED FOR RATIONAL METHOD
 NOTE: CONSIDER ALL CONFLUENCE STREAM COMBINATIONS
 FOR ALL DOWNSTREAM ANALYSES

USER-DEFINED STREET-SECTIONS FOR COUPLED PIPEFLOW AND STREETFLOW MODEL

NO.	HALF-WIDTH (FT)	CROWN TO CROSSFALL (FT)	STREET-CROSSFALL: IN- / OUT- / SIDE / SIDE / WAY	CURB HEIGHT (FT)	GUTTER WIDTH (FT)	GEOMETRIES: LIP (FT)	MANNING HIKE (FT)	FACTOR (n)
1	30.0	20.0	0.018/0.018/0.020	0.67	2.00	0.0313	0.167	0.0150

GLOBAL STREET FLOW-DEPTH CONSTRAINTS:

- 1. Relative Flow-Depth = 0.00 FEET
as (Maximum Allowable Street Flow Depth) - (Top-of-Curb)
- 2. (Depth)*(Velocity) Constraint = 6.0 (FT*FT/S)

SIZE PIPE WITH A FLOW CAPACITY GREATER THAN OR EQUAL TO THE UPSTREAM TRIBUTARY PIPE.

 FLOW PROCESS FROM NODE 26.10 TO NODE 26.20 IS CODE = 21

>>>>RATIONAL METHOD INITIAL SUBAREA ANALYSIS<<<<<

=====

ASSUMED INITIAL SUBAREA UNIFORM
 DEVELOPMENT IS SINGLE FAMILY (1/4 ACRE)
 TC = $K * [(LENGTH^{**3}) / (ELEVATION CHANGE)]^{**0.2}$
 INITIAL SUBAREA FLOW-LENGTH(FEET) = 635.00
 UPSTREAM ELEVATION(FEET) = 888.00
 DOWNSTREAM ELEVATION(FEET) = 881.40
 ELEVATION DIFFERENCE(FEET) = 6.60
 TC = $0.393 * [(635.00^{**3}) / (6.60)]^{**0.2} = 12.933$
 10 YEAR RAINFALL INTENSITY(INCH/HOUR) = 1.877
 SINGLE-FAMILY(1/4 ACRE LOT) RUNOFF COEFFICIENT = .7911
 SOIL CLASSIFICATION IS "C"
 SUBAREA RUNOFF(CFS) = 3.09
 TOTAL AREA(ACRES) = 2.08 TOTAL RUNOFF(CFS) = 3.09

+-----+
SUBAREA 0-2 TO PROPOSED CITY CATCH BASIN
 +-----+

 FLOW PROCESS FROM NODE 26.20 TO NODE 26.30 IS CODE = 41

>>>>COMPUTE PIPE-FLOW TRAVEL TIME THRU SUBAREA<<<<<
 >>>>USING USER-SPECIFIED PIPESIZE (EXISTING ELEMENT)<<<<<

=====

REPRESENTATIVE SLOPE = 0.0100
 FLOW LENGTH(FEET) = 31.08 MANNING'S N = 0.013
 DEPTH OF FLOW IN 18.0 INCH PIPE IS 6.8 INCHES
 PIPE-FLOW VELOCITY(FEET/SEC.) = 5.07
 GIVEN PIPE DIAMETER(INCH) = 18.00 NUMBER OF PIPES = 1
 PIPE-FLOW(CFS) = 3.09
 PIPE TRAVEL TIME(MIN.) = 0.10 Tc(MIN.) = 13.04
 LONGEST FLOWPATH FROM NODE 26.10 TO NODE 26.30 = 666.08 FEET.

=====

END OF STUDY SUMMARY:
 TOTAL AREA(ACRES) = 2.1 TC(MIN.) = 13.04
 PEAK FLOW RATE(CFS) = 3.09

=====
=====

END OF RATIONAL METHOD ANALYSIS



RATIONAL METHOD HYDROLOGY COMPUTER PROGRAM BASED ON
RIVERSIDE COUNTY FLOOD CONTROL & WATER CONSERVATION DISTRICT
(RCFC&WCD) 1978 HYDROLOGY MANUAL
(c) Copyright 1982-2016 Advanced Engineering Software (aes)
(Rational Tabling Version 23.0)
Release Date: 07/01/2016 License ID 1681

Analysis prepared by:

KHR Associates
17530 Von Karman Avenue
Irvine, CA 92626

***** DESCRIPTION OF STUDY *****

- * IRON LOFTS *
 - * POST-DEVELOPMENT HYDROLOGY - 6TH STREET RUNOFF NORTHERN HALF *
 - * 100-YEAR STORM EVENT *
- *****

FILE NAME: 6TH-STU.DAT
TIME/DATE OF STUDY: 15:23 07/26/2024

USER SPECIFIED HYDROLOGY AND HYDRAULIC MODEL INFORMATION:

USER SPECIFIED STORM EVENT(YEAR) = 100.00
SPECIFIED MINIMUM PIPE SIZE(INCH) = 4.00
SPECIFIED PERCENT OF GRADIENTS(DECIMAL) TO USE FOR FRICTION SLOPE = 0.95
10-YEAR STORM 10-MINUTE INTENSITY(INCH/HOUR) = 2.140
10-YEAR STORM 60-MINUTE INTENSITY(INCH/HOUR) = 0.800
100-YEAR STORM 10-MINUTE INTENSITY(INCH/HOUR) = 3.210
100-YEAR STORM 60-MINUTE INTENSITY(INCH/HOUR) = 1.200
SLOPE OF 10-YEAR INTENSITY-DURATION CURVE = 0.5491525
SLOPE OF 100-YEAR INTENSITY-DURATION CURVE = 0.5491524

COMPUTED RAINFALL INTENSITY DATA:

STORM EVENT = 100.00 1-HOUR INTENSITY(INCH/HOUR) = 1.200
SLOPE OF INTENSITY DURATION CURVE = 0.5492

RCFC&WCD HYDROLOGY MANUAL "C"-VALUES USED FOR RATIONAL METHOD

NOTE: CONSIDER ALL CONFLUENCE STREAM COMBINATIONS

FOR ALL DOWNSTREAM ANALYSES

USER-DEFINED STREET-SECTIONS FOR COUPLED PIPEFLOW AND STREETFLOW MODEL

NO.	HALF- CROWN TO		STREET-CROSSFALL:		CURB HEIGHT (FT)	GUTTER-GEOMETRIES:			MANNING FACTOR (n)
	WIDTH (FT)	CROSSFALL (FT)	IN- SIDE	OUT- / PARK- SIDE/ WAY		WIDTH (FT)	LIP (FT)	HIKE (FT)	
1	30.0	20.0	0.018	0.018/0.020	0.67	2.00	0.0313	0.167	0.0150

GLOBAL STREET FLOW-DEPTH CONSTRAINTS:

1. Relative Flow-Depth = 0.00 FEET
as (Maximum Allowable Street Flow Depth) - (Top-of-Curb)
 2. (Depth)*(Velocity) Constraint = 6.0 (FT*FT/S)
- *SIZE PIPE WITH A FLOW CAPACITY GREATER THAN
OR EQUAL TO THE UPSTREAM TRIBUTARY PIPE.*

FLOW PROCESS FROM NODE 26.10 TO NODE 26.20 IS CODE = 21

>>>>RATIONAL METHOD INITIAL SUBAREA ANALYSIS<<<<<

=====

ASSUMED INITIAL SUBAREA UNIFORM
DEVELOPMENT IS SINGLE FAMILY (1/4 ACRE)

TC = $K * [(LENGTH^{**3}) / (ELEVATION CHANGE)]^{**0.2}$
INITIAL SUBAREA FLOW-LENGTH(FEET) = 635.00
UPSTREAM ELEVATION(FEET) = 888.00
DOWNSTREAM ELEVATION(FEET) = 881.40
ELEVATION DIFFERENCE(FEET) = 6.60
TC = $0.393 * [(635.00^{**3}) / (6.60)]^{**0.2} = 12.933$
100 YEAR RAINFALL INTENSITY(INCH/HOUR) = 2.787
SINGLE-FAMILY(1/4 ACRE LOT) RUNOFF COEFFICIENT = .8204
SOIL CLASSIFICATION IS "C"
SUBAREA RUNOFF(CFS) = 4.76
TOTAL AREA(ACRES) = 2.08 TOTAL RUNOFF(CFS) = 4.76

+-----+
| SUBAREA 0-2 TO PROPOSED CITY CATCH BASIN |
+-----+

FLOW PROCESS FROM NODE 26.20 TO NODE 26.30 IS CODE = 41

>>>>COMPUTE PIPE-FLOW TRAVEL TIME THRU SUBAREA<<<<<
>>>>USING USER-SPECIFIED PIPESIZE (EXISTING ELEMENT)<<<<<

=====

REPRESENTATIVE SLOPE = 0.0100
FLOW LENGTH(FEET) = 31.08 MANNING'S N = 0.013
DEPTH OF FLOW IN 18.0 INCH PIPE IS 8.6 INCHES
PIPE-FLOW VELOCITY(FEET/SEC.) = 5.68
GIVEN PIPE DIAMETER(INCH) = 18.00 NUMBER OF PIPES = 1
PIPE-FLOW(CFS) = 4.76
PIPE TRAVEL TIME(MIN.) = 0.09 Tc(MIN.) = 13.02
LONGEST FLOWPATH FROM NODE 26.10 TO NODE 26.30 = 666.08 FEET.

=====

END OF STUDY SUMMARY:
TOTAL AREA(ACRES) = 2.1 TC(MIN.) = 13.02
PEAK FLOW RATE(CFS) = 4.76

=====

=====
END OF RATIONAL METHOD ANALYSIS



Iron Lofts
Hydraulic Grade Line
Line A - 100-Year Storm Event

Station	Invert Elev	Depth (FT)	Water Elev	Q (CFS)	Vel (FPS)	Vel Head	Energy Grd.El.	Super Elev	Critical Depth	Flow Top Width	Height/Dia.-FT	Base Wt or I.D.	ZL	No Wth Prs/Pip
L/Elem	Ch Slope					SF Ave	HF	SE Dpth	Froude N	Norm Dp	"N"	X-Fall	ZR	Type Ch
103.000	865.040	2.212	867.252	46.11	8.25	1.06	868.31	.00	2.21	2.64	3.000	.000	.00	1 .0
5.332	.0040					.0057	.03	2.21	1.00	3.00	.013	.00	.00	PIPE
108.332	865.061	2.317	867.378	46.11	7.87	.96	868.34	.00	2.21	2.52	3.000	.000	.00	1 .0
27.375	.0040					.0051	.14	2.32	.91	3.00	.013	.00	.00	PIPE
135.707	865.171	2.435	867.606	46.11	7.50	.87	868.48	.00	2.21	2.35	3.000	.000	.00	1 .0
76.753	.0040					.0047	.36	2.44	.82	3.00	.013	.00	.00	PIPE
212.460	865.478	2.562	868.040	46.11	7.17	.80	868.84	.00	2.21	2.12	3.000	.000	.00	1 .0
JUNCT STR	.0533					.0035	.01	2.56	.73		.013	.00	.00	PIPE
216.210	865.678	3.143	868.821	34.04	4.82	.36	869.18	.00	1.90	.00	3.000	.000	.00	1 .0
69.250	.0040					.0026	.18	3.14	.00	2.04	.013	.00	.00	PIPE
285.460	865.955	3.100	869.055	34.04	4.82	.36	869.42	.00	1.90	.00	3.000	.000	.00	1 .0
JUNCT STR	.0255					.0063	.03	3.10	.00		.013	.00	.00	PIPE
289.460	866.057	3.022	869.079	22.71	7.23	.81	869.89	.00	1.70	.00	2.000	.000	.00	1 .0
106.500	.0169					.0101	1.07	3.02	.00	1.32	.013	.00	.00	PIPE
395.960	867.855	2.378	870.233	22.71	7.23	.81	871.04	.00	1.70	.00	2.000	.000	.00	1 .0
JUNCT STR	.0536					.0101	.04	2.38	.00		.013	.00	.00	PIPE
399.710	868.056	2.215	870.271	22.71	7.23	.81	871.08	.00	1.70	.00	2.000	.000	.00	1 .0
59.444	.0150					.0101	.60	2.22	.00	1.38	.013	.00	.00	PIPE

Iron Lofts
Hydraulic Grade Line
Line A - 100-Year Storm Event

Station	Invert Elev	Depth (FT)	Water Elev	Q (CFS)	Vel (FPS)	Vel Head	Energy Grd.El.	Super Elev	Critical Depth	Flow Top Width	Height/Dia.-FT	Base Wt/or I.D.	ZL	No Wth Prs/Pip
L/Elem	Ch Slope					SF Ave	HF	SE Dpth	Froude N	Norm Dp	"N"	X-Fall	ZR	Type Ch
459.154	868.950	2.032	870.982	22.71	7.23	.81	871.79	.00	1.70	.00	2.000	.000	.00	1 .0
HYDRAULIC JUMP														
459.154	868.950	1.377	870.326	22.71	9.85	1.51	871.83	.00	1.70	1.85	2.000	.000	.00	1 .0
64.342	.0150					.0150	.97	1.38	1.56	1.38	.013	.00	.00	PIPE
523.497	869.917	1.377	871.293	22.71	9.85	1.51	872.80	.00	1.70	1.85	2.000	.000	.00	1 .0
97.563	.0150					.0152	1.48	1.38	1.56	1.38	.013	.00	.00	PIPE
621.060	871.383	1.364	872.747	22.71	9.95	1.54	874.28	.00	1.70	1.86	2.000	.000	.00	1 .0
JUNCT STR														
	.0736					.0135	.04	1.36	1.58		.013	.00	.00	PIPE
623.790	871.584	1.528	873.112	22.71	8.82	1.21	874.32	.00	1.70	1.70	2.000	.000	.00	1 .0
6.804	.0120					.0116	.08	1.53	1.26	1.51	.013	.00	.00	PIPE
630.594	871.666	1.532	873.198	22.71	8.79	1.20	874.40	.00	1.70	1.69	2.000	.000	.00	1 .0
33.037	.0120					.0110	.36	1.53	1.25	1.51	.013	.00	.00	PIPE
663.631	872.062	1.608	873.670	22.71	8.38	1.09	874.76	.00	1.70	1.59	2.000	.000	.00	1 .0
5.519	.0120					.0100	.06	1.61	1.13	1.51	.013	.00	.00	PIPE
669.150	872.128	1.697	873.825	22.71	7.99	.99	874.82	.00	1.70	1.43	2.000	.000	.00	1 .0
675.300	872.590	1.697	874.287	22.71	7.99	.99	875.28	.00	1.70	1.43	2.000	.000	.00	1 .0



Iron Lofts
 Hydraulic Grade Line
 Line A - 100-Year Storm Event

Station	Invert Elev	Depth (FT)	Water Elev	Q (CFS)	Vel (FPS)	Vel Head	Energy Grd.El.	Super Elev	Critical Depth	Flow Top Width	Height/Dia.-FT	Base Wt or I.D.	ZL	No Wth Prs/Pip
L/Elem	Ch Slope					SF Ave	HF	SE Dpth	Froude N	Norm Dp	"N"	X-Fall	ZR	Type Ch
675.300	872.590	.716	873.306	4.76	5.72	.51	873.81	.00	.84	1.50	1.500	.000	.00	1 .0
5.730	.0100					.0095	.05	.72	1.35	.71	.013	.00	.00	PIPE
681.031	872.647	.719	873.366	4.76	5.68	.50	873.87	.00	.84	1.50	1.500	.000	.00	1 .0
16.128	.0100					.0089	.14	.72	1.34	.71	.013	.00	.00	PIPE
697.158	872.808	.747	873.555	4.76	5.41	.46	874.01	.00	.84	1.50	1.500	.000	.00	1 .0
6.234	.0100					.0078	.05	.75	1.25	.71	.013	.00	.00	PIPE
703.392	872.870	.775	873.645	4.76	5.16	.41	874.06	.00	.84	1.50	1.500	.000	.00	1 .0
2.476	.0100					.0069	.02	.78	1.16	.71	.013	.00	.00	PIPE
705.868	872.895	.805	873.700	4.76	4.92	.38	874.08	.00	.84	1.50	1.500	.000	.00	1 .0
.512	.0100					.0061	.00	.81	1.08	.71	.013	.00	.00	PIPE
706.380	872.900	.838	873.738	4.76	4.69	.34	874.08	.00	.84	1.49	1.500	.000	.00	1 .0
711.700	873.350	.838	874.188	4.76	4.69	.34	874.53	.00	.84	1.49	1.500	.000	.00	1 .0

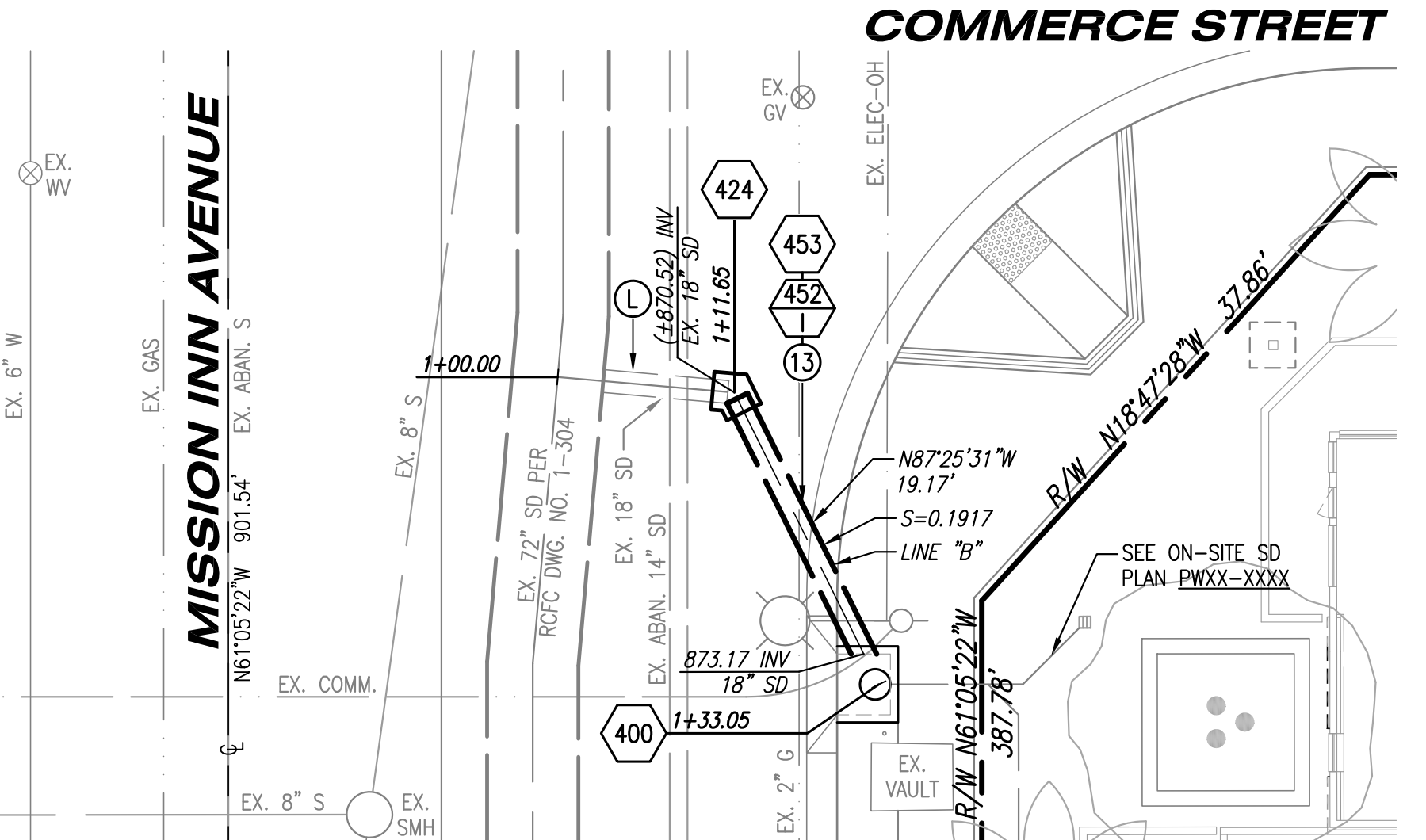
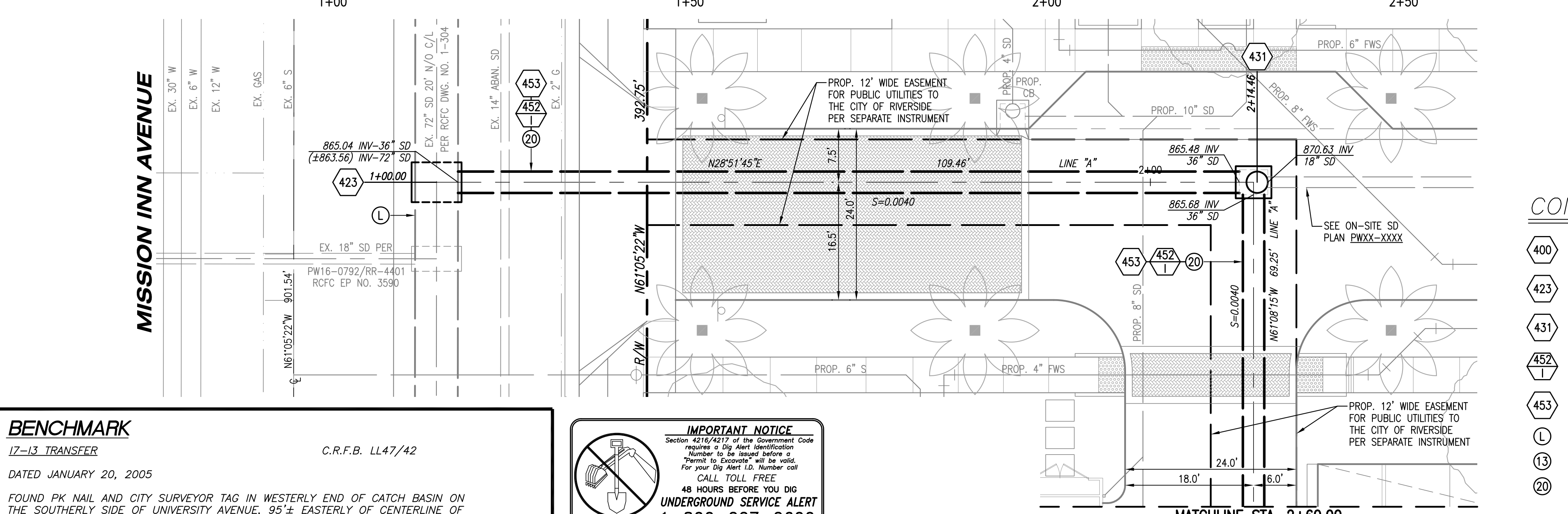
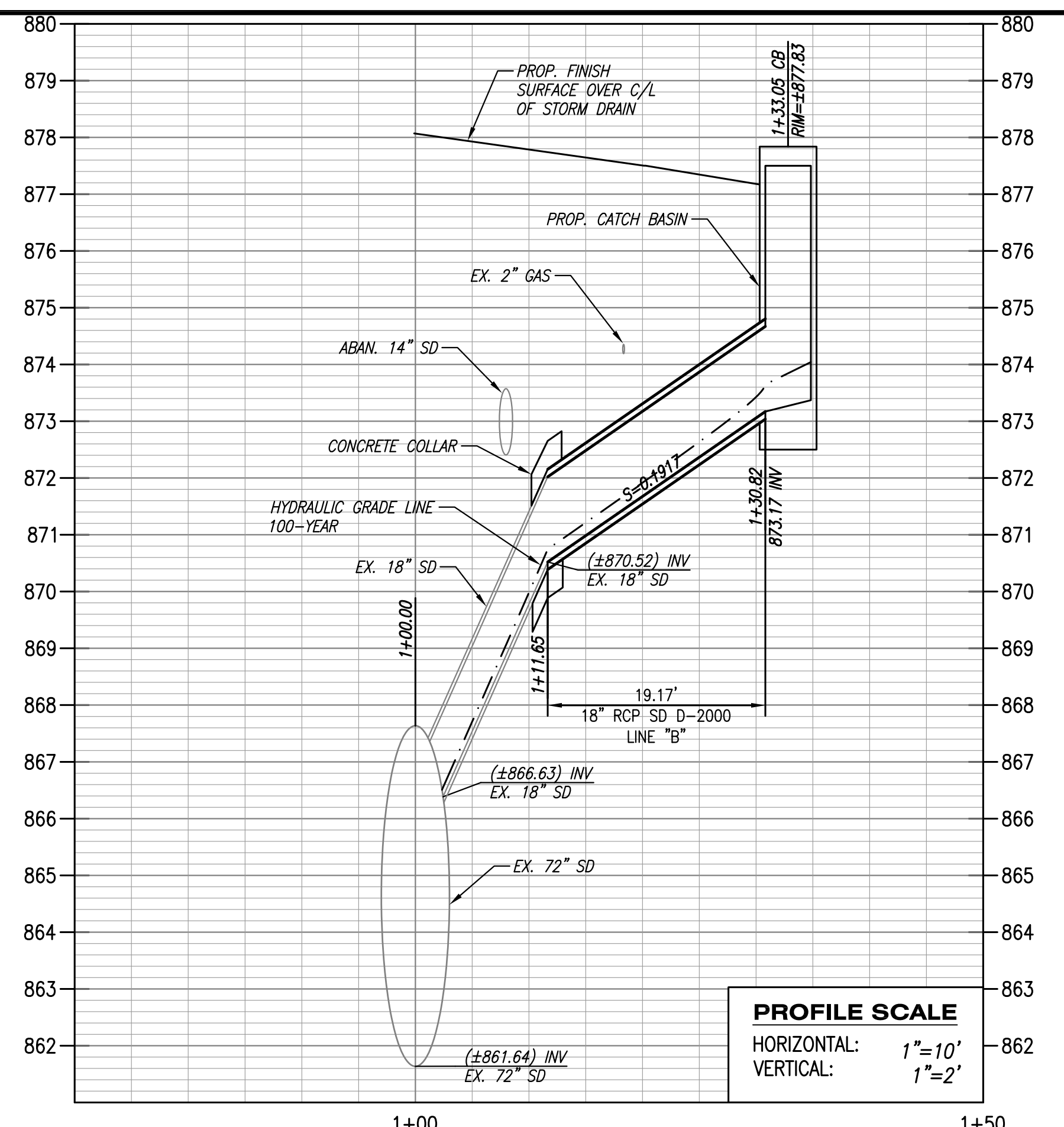
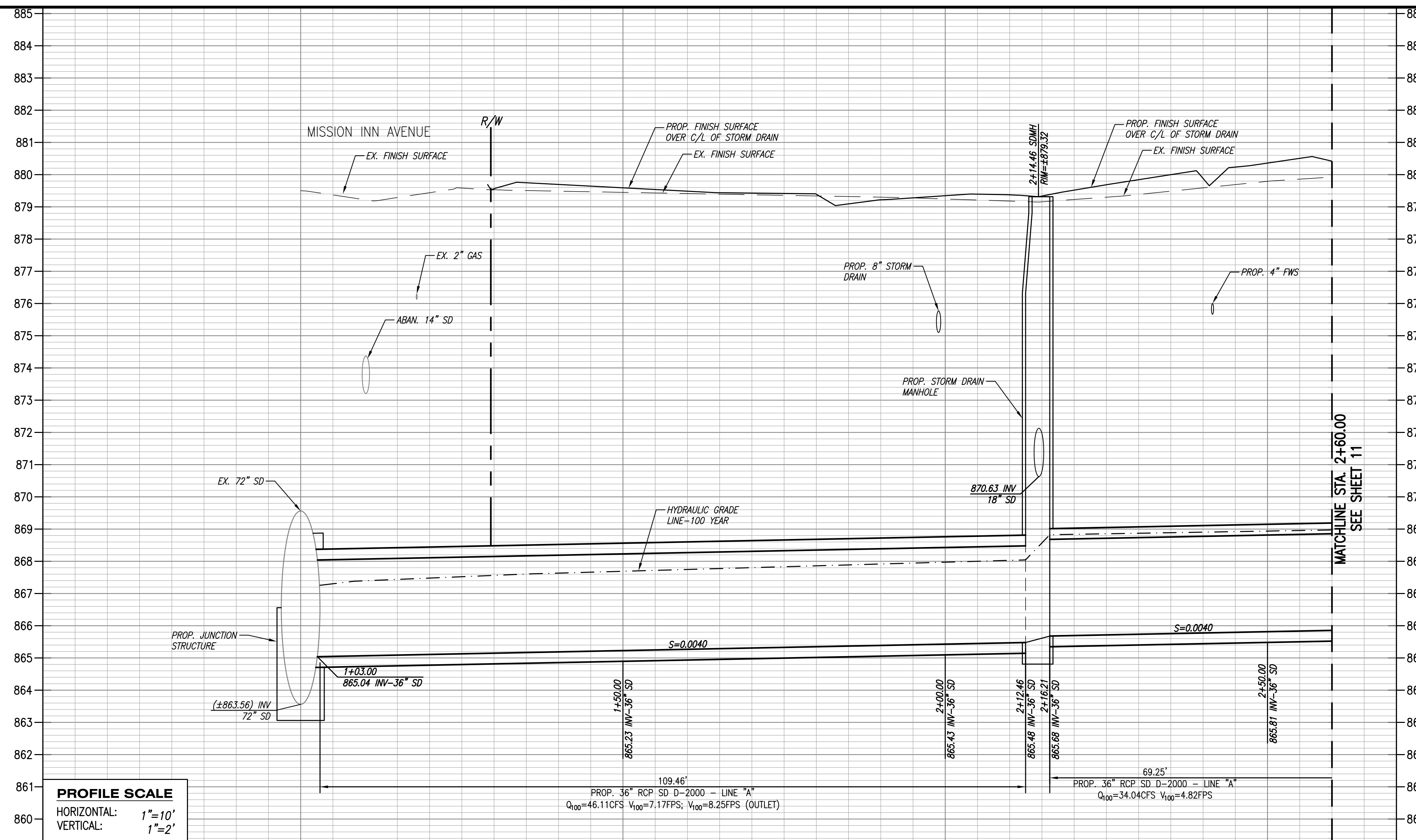

BENCHMARK
 17-13 TRANSFER
 C.R.F.B. LL47/42
 DATED JANUARY 20, 2005
 FOUND PK NAIL AND CITY SURVEYOR TAG IN WESTERLY END OF CATCH BASIN ON THE SOUTHERLY SIDE OF UNIVERSITY AVENUE, 95' ± EASTERLY OF CENTERLINE OF PARK AVENUE.
 ELEVATION: 891.353 FEET (NGVD 29)

IMPORTANT NOTICE
 Section 4216/4217 of the Government Code requires a Dig Alert Identification Number to be issued before a Permit to Excavate will be valid. For your Dig Alert I.D. Number call CALL TOLL FREE 48 HOURS BEFORE YOU DIG UNDERGROUND SERVICE ALERT 1-800-227-2600

CONSTRUCTION NOTES

- 400 CONSTRUCT CATCH BASIN TYPE 1 PER CITY STANDARD DRAWING 400.
- 423 CONSTRUCT JUNCTION STRUCTURE NO. 4 PER RCFC STANDARD DRAWING JS229, CASE 1.
- 431 CONSTRUCT MANHOLE EZ PER CITY STANDARD DRAWING 431.
- 452 CONSTRUCT PIPE BEDDING PER CITY STANDARD DRAWING 452, CASE I. EXCLUDE SAND AND NATIVE MATERIAL.
- 453 CONSTRUCT TRENCH BACKFILL PER CITY STANDARD DRAWING 453.
- Ⓛ PROTECT IN PLACE EXISTING STORM DRAIN AND STORM DRAIN MANHOLE.
- 13 PROVIDE AND INSTALL 18-INCH RCP D-LOAD 2000 DRAINAGE PIPE. SEE SHEET 12.
- 20 PROVIDE AND INSTALL 36-INCH RCP D-LOAD 2000 DRAINAGE PIPE. SEE SHEETS 10 & 11.

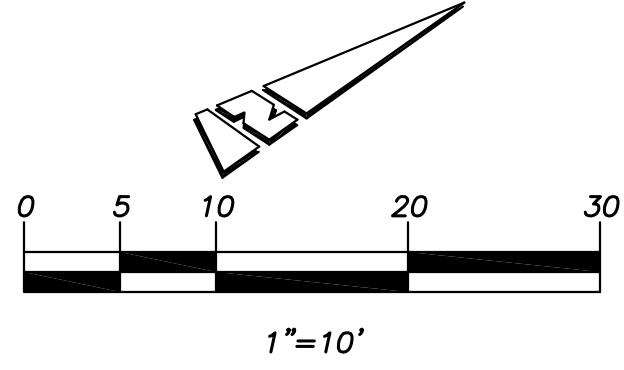

PREPARED BY:
KHR ASSOCIATES
 CONSULTING ENGINEERS/SURVEYORS/PLANNERS
 17530 Von Karman Ave., Suite 200
 Irvine, California 92614
 UNDER THE SUPERVISION OF: JAMES H. KAWAMURA (R.C.E. 30560)

ENGINEER IN RESPONSIBLE CHARGE
James H. Kawamura
 JAMES H. KAWAMURA
 R.C.E. No. 30560 expires 3/31/26
 DATE XXXXXXXX XX, 2024

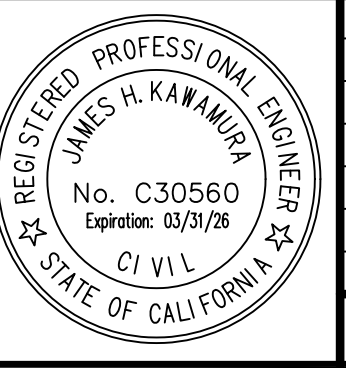

MARK	REVISIONS	APPR.	DATE

DESIGNED BY *MMK* DRAWN BY *MMK* CHECKED BY *JHK*

CITY OF RIVERSIDE
 PUBLIC UTILITIES DEPARTMENT
 WATER DIVISION
 REVIEWED FOR CONFLICTS DATE

CITY OF RIVERSIDE
 PUBLIC UTILITIES DEPARTMENT
 ELECTRIC DIVISION
 REVIEWED FOR CONFLICTS DATE

CITY OF RIVERSIDE, CALIFORNIA
 PUBLIC WORKS DEPARTMENT

APPROVED BY	BY	DATE	APPROVED BY

CITY ENGINEER
 DATE

PWXX-XXXX RCFC EP NO. XXXX
IRON LOFTS
 STREET IMPROVEMENT PLAN
 STORM DRAIN PLAN AND PROFILE
 RIVERSIDE, CALIFORNIA
 HORIZONTAL SCALE: 1"=10' VERTICAL SCALE: 1"=2'

ACCT. NO.
R-XXXX
 SHEET 10 OF 19

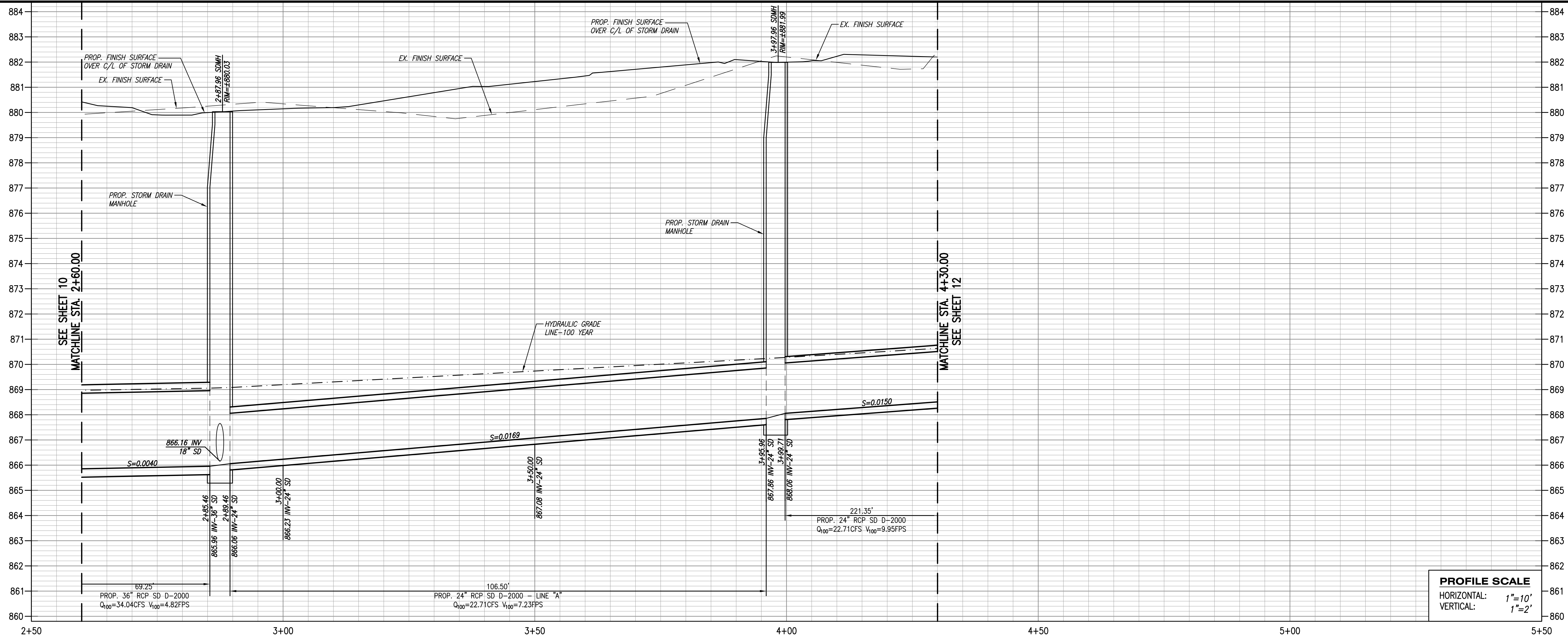

PROFILE SCALE
 HORIZONTAL: 1"=10'
 VERTICAL: 1"=2'

CONSTRUCTION NOTES

- 431 CONSTRUCT MANHOLE EZ PER CITY STANDARD DRAWING 431.
- 452 CONSTRUCT PIPE BEDDING PER CITY STANDARD DRAWING 452, CASE I. EXCLUDE SAND AND NATIVE MATERIAL.
- 453 CONSTRUCT TRENCH BACKFILL PER CITY STANDARD DRAWING 453.
- 14 PROVIDE AND INSTALL 24-INCH RCP D-LOAD 2000 DRAINAGE PIPE. SEE SHEETS 11 & 12.
- 20 PROVIDE AND INSTALL 36-INCH RCP D-LOAD 2000 DRAINAGE PIPE. SEE SHEETS 10 & 11.

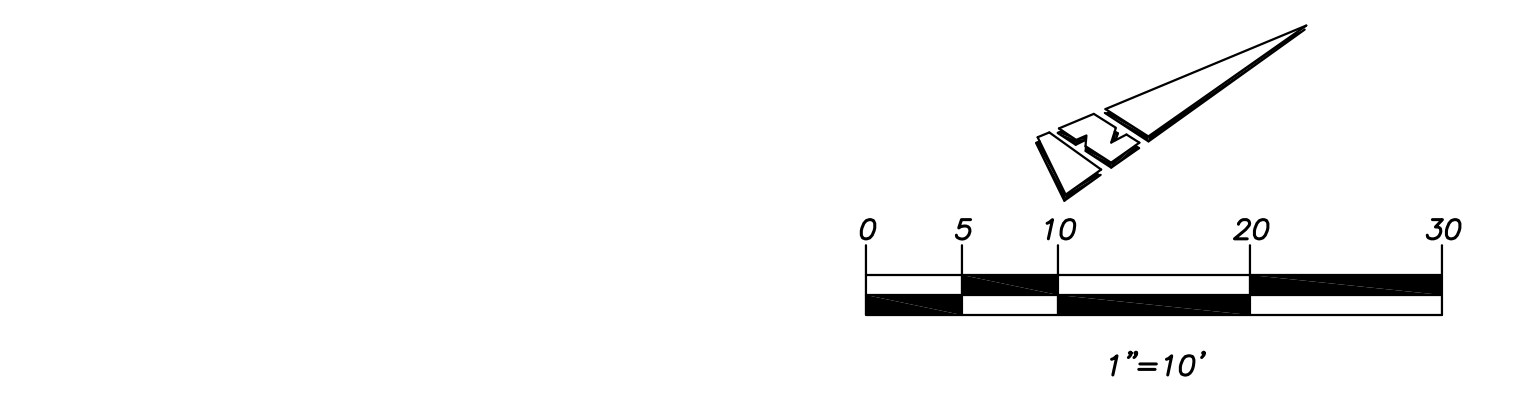
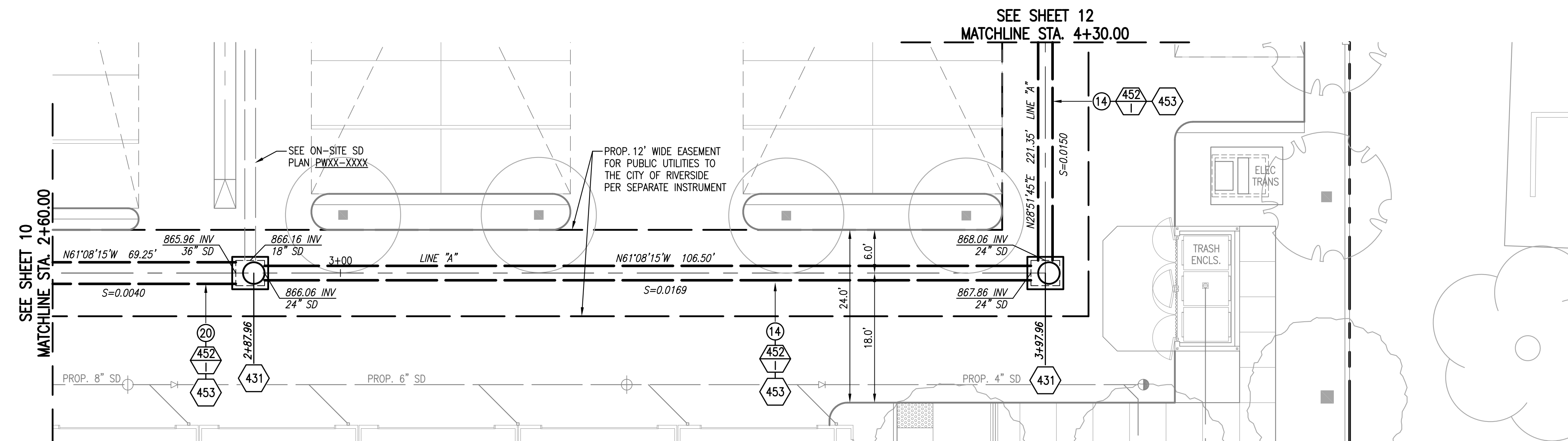

BENCHMARK
 17-13 TRANSFER C.R.F.B. LL47/42
 DATED JANUARY 20, 2005
 FOUND PK NAIL AND CITY SURVEYOR TAG IN WESTERLY END OF CATCH BASIN ON THE SOUTHERLY SIDE OF UNIVERSITY AVENUE, 95'± EASTERLY OF CENTERLINE OF PARK AVENUE.
 ELEVATION: 891.353 FEET (NGVD 29)

IMPORTANT NOTICE
 Section 4216/4217 of the Government Code requires a Dig Alert Identification Number to be issued before a Permit to Excavate will be valid. For your Dig Alert I.D. Number call CALL TOLL FREE 48 HOURS BEFORE YOU DIG UNDERGROUND SERVICE ALERT 1-800-227-2600

PREPARED BY:
KHR ASSOCIATES
 CONSULTING ENGINEERS/SURVEYORS/PLANNERS
 17530 Von Karman Ave., Suite 200 Tel (949) 756-6440
 Irvine, California 92614

ENGINEER IN RESPONSIBLE CHARGE

 JAMES H. KAWAMURA
 R.C.E. No. 30560 expires 3/31/26
 DATE XXXXXXXX XX, 2024

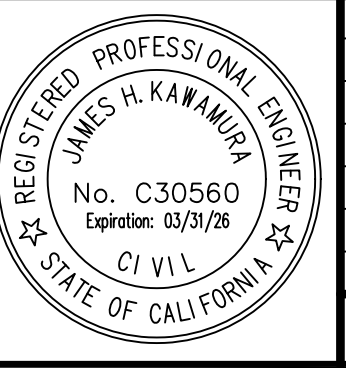

MARK	REVISIONS	APPR.	DATE

DESIGNED BY *MMK* DRAWN BY *MMK* CHECKED BY *JHK*

CITY OF RIVERSIDE
 PUBLIC UTILITIES DEPARTMENT
 WATER DIVISION

CITY OF RIVERSIDE
 PUBLIC UTILITIES DEPARTMENT
 ELECTRIC DIVISION

CITY OF RIVERSIDE, CALIFORNIA
 PUBLIC WORKS DEPARTMENT

APPROVED BY	BY	DATE	APPROVED BY

CITY ENGINEER

PWXX-XXXX

IRON LOFTS
 STREET IMPROVEMENT PLAN
 STORM DRAIN PLAN AND PROFILE
 RIVERSIDE, CALIFORNIA

ACCT. NO. **R-XXXX**
 SHEET 11 OF 19

HORIZONTAL SCALE: 1"=10' VERTICAL SCALE: 1"=2'

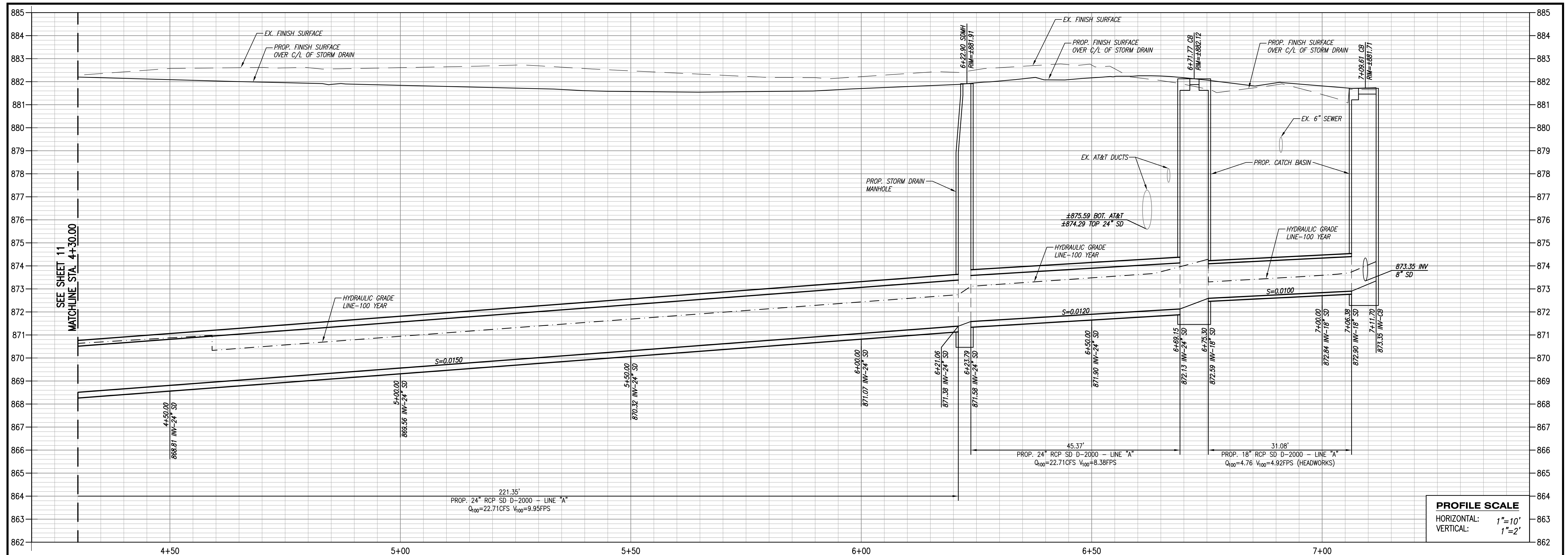

PROFILE SCALE
 HORIZONTAL: 1"=10'
 VERTICAL: 1"=2'

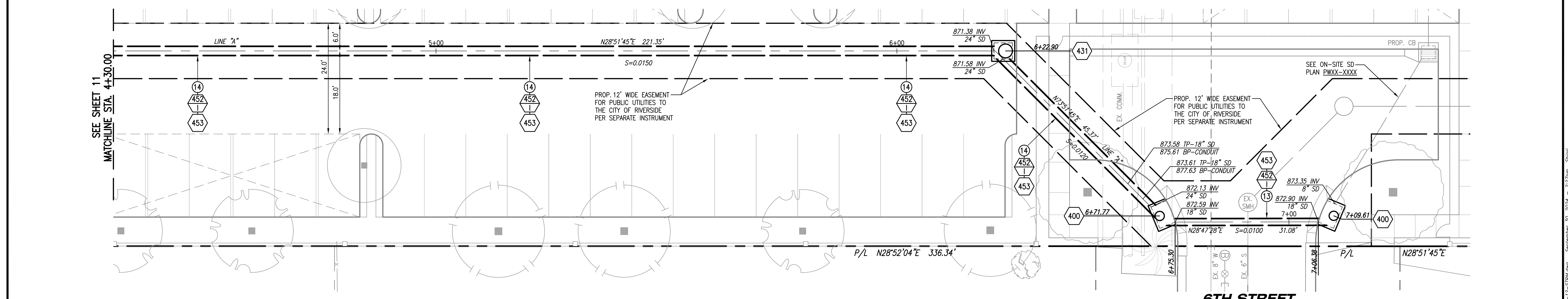

CONSTRUCTION NOTES

- 400 CONSTRUCT CATCH BASIN TYPE 1 PER CITY STANDARD DRAWING 400.
- 431 CONSTRUCT MANHOLE EZ PER CITY STANDARD DRAWING 431.
- 452 CONSTRUCT PIPE BEDDING PER CITY STANDARD DRAWING 452, CASE I. EXCLUDE SAND AND NATIVE MATERIAL.
- 453 CONSTRUCT TRENCH BACKFILL PER CITY STANDARD DRAWING 453.
- 13 PROVIDE AND INSTALL 18-INCH RCP D-LOAD 2000 DRAINAGE PIPE. SEE SHEET 12.
- 14 PROVIDE AND INSTALL 24-INCH RCP D-LOAD 2000 DRAINAGE PIPE. SEE SHEETS 11 & 12.

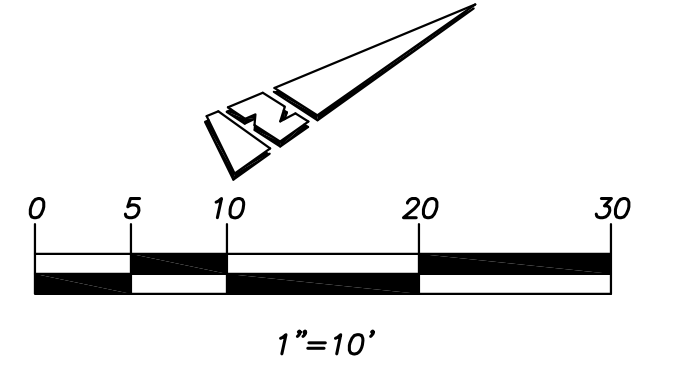

BENCHMARK
 17-13 TRANSFER C.R.F.B. LL47/42
 DATED JANUARY 20, 2005
 FOUND PK NAIL AND CITY SURVEYOR TAG IN WESTERLY END OF CATCH BASIN ON THE SOUTHERLY SIDE OF UNIVERSITY AVENUE, 95'± EASTERLY OF CENTERLINE OF PARK AVENUE.
 ELEVATION: 891.353 FEET (NGVD 29)

IMPORTANT NOTICE
 Section 4216/4217 of the Government Code requires a Dig Alert Identification Number to be issued before a "Permit to Excavate" will be voided. For your Dig Alert I.D. Number call CALL TOLL FREE 48 HOURS BEFORE YOU DIG UNDERGROUND SERVICE ALERT 1-800-227-2600

PREPARED BY:
KHR ASSOCIATES
 CONSULTING ENGINEERS/SURVEYORS/PLANNERS
 17530 Von Karman Ave. - Suite 200 Tel (949) 756-6440
 Irvine, California 92614

ENGINEER IN RESPONSIBLE CHARGE
 JAMES H. KAWAMURA
 R.C.E. No. 30560 expires 3/31/26
 DATE XXXXXXXX XX, 2024

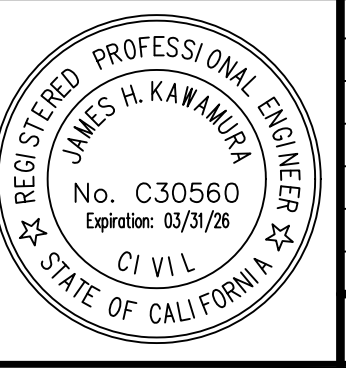

MARK	REVISIONS	APPR.	DATE

CITY OF RIVERSIDE
 PUBLIC UTILITIES DEPARTMENT
 WATER DIVISION

CITY OF RIVERSIDE
 PUBLIC UTILITIES DEPARTMENT
 ELECTRIC DIVISION

CITY OF RIVERSIDE, CALIFORNIA
 PUBLIC WORKS DEPARTMENT

APPROVED BY	BY	DATE	APPROVED BY

PWXX-XXXX

IRON LOFTS
STREET IMPROVEMENT PLAN
STORM DRAIN PLAN AND PROFILE
 RIVERSIDE, CALIFORNIA

ACC'T. NO. **R-XXXX**
 SHEET **12** OF **19**

HORIZONTAL SCALE: 1"=10'
 VERTICAL SCALE: 1"=2'

Pipe Capacity: 36" SD @0.004 - Discharging Outlet

Project Description	
Friction Method	Manning Formula
Solve For	Normal Depth
Input Data	
Roughness Coefficient	0.013
Channel Slope	0.004 ft/ft
Diameter	36.0 in
Discharge	36.04 cfs
Results	
Normal Depth	25.6 in
Flow Area	5.4 ft ²
Wetted Perimeter	6.0 ft
Hydraulic Radius	10.7 in
Top Width	2.72 ft
Critical Depth	23.4 in
Percent Full	71.1 %
Critical Slope	0.005 ft/ft
Velocity	6.70 ft/s
Velocity Head	0.70 ft
Specific Energy	2.83 ft
Froude Number	0.841
Maximum Discharge	45.37 cfs
Discharge Full	42.18 cfs
Slope Full	0.003 ft/ft
Flow Type	Subcritical
GVF Input Data	
Downstream Depth	0.0 in
Length	0.0 ft
Number Of Steps	0
GVF Output Data	
Upstream Depth	0.0 in
Profile Description	N/A
Profile Headloss	0.00 ft
Average End Depth Over Rise	0.0 %
Normal Depth Over Rise	57.6 %
Downstream Velocity	Infinity ft/s
Upstream Velocity	Infinity ft/s
Normal Depth	25.6 in
Critical Depth	23.4 in
Channel Slope	0.004 ft/ft
Critical Slope	0.005 ft/ft

Pipe Capacity: 36" SD @0.004 - Off-site plus On-site Overflow

Project Description	
Friction Method	Manning Formula
Solve For	Normal Depth
Input Data	
Roughness Coefficient	0.013
Channel Slope	0.004 ft/ft
Diameter	36.0 in
Discharge	29.63 cfs
Results	
Normal Depth	22.2 in
Flow Area	4.6 ft ²
Wetted Perimeter	5.4 ft
Hydraulic Radius	10.1 in
Top Width	2.92 ft
Critical Depth	21.2 in
Percent Full	61.8 %
Critical Slope	0.005 ft/ft
Velocity	6.46 ft/s
Velocity Head	0.65 ft
Specific Energy	2.50 ft
Froude Number	0.908
Maximum Discharge	45.37 cfs
Discharge Full	42.18 cfs
Slope Full	0.002 ft/ft
Flow Type	Subcritical
GVF Input Data	
Downstream Depth	0.0 in
Length	0.0 ft
Number Of Steps	0
GVF Output Data	
Upstream Depth	0.0 in
Profile Description	N/A
Profile Headloss	0.00 ft
Average End Depth Over Rise	0.0 %
Normal Depth Over Rise	64.2 %
Downstream Velocity	Infinity ft/s
Upstream Velocity	Infinity ft/s
Normal Depth	22.2 in
Critical Depth	21.2 in
Channel Slope	0.004 ft/ft
Critical Slope	0.005 ft/ft

Pipe Capacity: 24"SD @0.0169

Project Description	
Friction Method	Manning Formula
Solve For	Normal Depth
Input Data	
Roughness Coefficient	0.013
Channel Slope	0.017 ft/ft
Diameter	24.0 in
Discharge	22.71 cfs
Results	
Normal Depth	15.8 in
Flow Area	2.2 ft ²
Wetted Perimeter	3.8 ft
Hydraulic Radius	7.0 in
Top Width	1.90 ft
Critical Depth	20.4 in
Percent Full	66.0 %
Critical Slope	0.010 ft/ft
Velocity	10.33 ft/s
Velocity Head	1.66 ft
Specific Energy	2.98 ft
Froude Number	1.691
Maximum Discharge	31.63 cfs
Discharge Full	29.41 cfs
Slope Full	0.010 ft/ft
Flow Type	Supercritical
GVF Input Data	
Downstream Depth	0.0 in
Length	0.0 ft
Number Of Steps	0
GVF Output Data	
Upstream Depth	0.0 in
Profile Description	N/A
Profile Headloss	0.00 ft
Average End Depth Over Rise	0.0 %
Normal Depth Over Rise	66.0 %
Downstream Velocity	Infinity ft/s
Upstream Velocity	Infinity ft/s
Normal Depth	15.8 in
Critical Depth	20.4 in
Channel Slope	0.017 ft/ft
Critical Slope	0.010 ft/ft

Pipe Capacity: 24" SD @0.0150

Project Description	
Friction Method	Manning Formula
Solve For	Normal Depth
Input Data	
Roughness Coefficient	0.013
Channel Slope	0.015 ft/ft
Diameter	24.0 in
Discharge	22.71 cfs
Results	
Normal Depth	16.5 in
Flow Area	2.3 ft ²
Wetted Perimeter	3.9 ft
Hydraulic Radius	7.1 in
Top Width	1.85 ft
Critical Depth	20.4 in
Percent Full	68.9 %
Critical Slope	0.010 ft/ft
Velocity	9.84 ft/s
Velocity Head	1.50 ft
Specific Energy	2.88 ft
Froude Number	1.554
Maximum Discharge	29.80 cfs
Discharge Full	27.71 cfs
Slope Full	0.010 ft/ft
Flow Type	Supercritical
GVF Input Data	
Downstream Depth	0.0 in
Length	0.0 ft
Number Of Steps	0
GVF Output Data	
Upstream Depth	0.0 in
Profile Description	N/A
Profile Headloss	0.00 ft
Average End Depth Over Rise	0.0 %
Normal Depth Over Rise	68.9 %
Downstream Velocity	Infinity ft/s
Upstream Velocity	Infinity ft/s
Normal Depth	16.5 in
Critical Depth	20.4 in
Channel Slope	0.015 ft/ft
Critical Slope	0.010 ft/ft

Pipe Capacity: 24" SD @0.0120

Project Description	
Friction Method	Manning Formula
Solve For	Normal Depth
Input Data	
Roughness Coefficient	0.013
Channel Slope	0.012 ft/ft
Diameter	24.0 in
Discharge	22.71 cfs
Results	
Normal Depth	18.1 in
Flow Area	2.5 ft ²
Wetted Perimeter	4.2 ft
Hydraulic Radius	7.2 in
Top Width	1.72 ft
Critical Depth	20.4 in
Percent Full	75.3 %
Critical Slope	0.010 ft/ft
Velocity	8.95 ft/s
Velocity Head	1.24 ft
Specific Energy	2.75 ft
Froude Number	1.300
Maximum Discharge	26.66 cfs
Discharge Full	24.78 cfs
Slope Full	0.010 ft/ft
Flow Type	Supercritical
GVF Input Data	
Downstream Depth	0.0 in
Length	0.0 ft
Number Of Steps	0
GVF Output Data	
Upstream Depth	0.0 in
Profile Description	N/A
Profile Headloss	0.00 ft
Average End Depth Over Rise	0.0 %
Normal Depth Over Rise	75.3 %
Downstream Velocity	Infinity ft/s
Upstream Velocity	Infinity ft/s
Normal Depth	18.1 in
Critical Depth	20.4 in
Channel Slope	0.012 ft/ft
Critical Slope	0.010 ft/ft

Pipe Capacity: 18" SD @0.010

Project Description	
Friction Method	Manning Formula
Solve For	Normal Depth
Input Data	
Roughness Coefficient	0.013
Channel Slope	0.010 ft/ft
Diameter	18.0 in
Discharge	4.76 cfs
Results	
Normal Depth	8.5 in
Flow Area	0.8 ft ²
Wetted Perimeter	2.3 ft
Hydraulic Radius	4.3 in
Top Width	1.50 ft
Critical Depth	10.1 in
Percent Full	47.2 %
Critical Slope	0.006 ft/ft
Velocity	5.80 ft/s
Velocity Head	0.52 ft
Specific Energy	1.23 ft
Froude Number	1.381
Maximum Discharge	11.30 cfs
Discharge Full	10.50 cfs
Slope Full	0.002 ft/ft
Flow Type	Supercritical
GVF Input Data	
Downstream Depth	0.0 in
Length	0.0 ft
Number Of Steps	0
GVF Output Data	
Upstream Depth	0.0 in
Profile Description	N/A
Profile Headloss	0.00 ft
Average End Depth Over Rise	0.0 %
Normal Depth Over Rise	47.2 %
Downstream Velocity	Infinity ft/s
Upstream Velocity	Infinity ft/s
Normal Depth	8.5 in
Critical Depth	10.1 in
Channel Slope	0.010 ft/ft
Critical Slope	0.006 ft/ft

Appendix 2.1.1

Post-Development Hydrology Calculations: On-Site Only

RATIONAL METHOD HYDROLOGY COMPUTER PROGRAM BASED ON
RIVERSIDE COUNTY FLOOD CONTROL & WATER CONSERVATION DISTRICT
(RCFC&WCD) 1978 HYDROLOGY MANUAL
(c) Copyright 1982-2016 Advanced Engineering Software (aes)
(Rational Tabling Version 23.0)
Release Date: 07/01/2016 License ID 1681

Analysis prepared by:

KHR Associates
17530 Von Karman Avenue
Irvine, CA 92626

***** DESCRIPTION OF STUDY *****

- * IRON LOFTS *
 - * POST-DEVELOPMENT HYDROLOGY - ON-SITE ONLY *
 - * 10-YEAR STORM EVENT *
- *****

FILE NAME: RIL1-S10.DAT
TIME/DATE OF STUDY: 12:44 08/02/2024

USER SPECIFIED HYDROLOGY AND HYDRAULIC MODEL INFORMATION:

USER SPECIFIED STORM EVENT(YEAR) = 10.00
SPECIFIED MINIMUM PIPE SIZE(INCH) = 4.00
SPECIFIED PERCENT OF GRADIENTS(DECIMAL) TO USE FOR FRICTION SLOPE = 0.95
10-YEAR STORM 10-MINUTE INTENSITY(INCH/HOUR) = 2.140
10-YEAR STORM 60-MINUTE INTENSITY(INCH/HOUR) = 0.800
100-YEAR STORM 10-MINUTE INTENSITY(INCH/HOUR) = 3.210
100-YEAR STORM 60-MINUTE INTENSITY(INCH/HOUR) = 1.200
SLOPE OF 10-YEAR INTENSITY-DURATION CURVE = 0.5491525
SLOPE OF 100-YEAR INTENSITY-DURATION CURVE = 0.5491524

COMPUTED RAINFALL INTENSITY DATA:

STORM EVENT = 10.00 1-HOUR INTENSITY(INCH/HOUR) = 0.808

SLOPE OF INTENSITY DURATION CURVE = 0.5492

RCFC&WCD HYDROLOGY MANUAL "C"-VALUES USED FOR RATIONAL METHOD

NOTE: CONSIDER ALL CONFLUENCE STREAM COMBINATIONS

FOR ALL DOWNSTREAM ANALYSES

USER-DEFINED STREET-SECTIONS FOR COUPLED PIPEFLOW AND STREETFLOW MODEL

NO.	HALF-WIDTH (FT)	CROWN TO CROSSFALL (FT)	STREET-CROSSFALL IN-SIDE / OUT-SIDE/PARK-WAY	CURB HEIGHT (FT)	GUTTER WIDTH (FT)	GEOMETRIES LIP (FT)	MANNING HIKE (FT)	FACTOR (n)
1	30.0	20.0	0.018/0.018/0.020	0.67	2.00	0.0313	0.167	0.0150

GLOBAL STREET FLOW-DEPTH CONSTRAINTS:

1. Relative Flow-Depth = 0.00 FEET
as (Maximum Allowable Street Flow Depth) - (Top-of-Curb)
 2. (Depth)*(Velocity) Constraint = 6.0 (FT*FT/S)
- *SIZE PIPE WITH A FLOW CAPACITY GREATER THAN
OR EQUAL TO THE UPSTREAM TRIBUTARY PIPE.*

FLOW PROCESS FROM NODE 1.00 TO NODE 2.00 IS CODE = 21

>>>>RATIONAL METHOD INITIAL SUBAREA ANALYSIS<<<<<

=====

ASSUMED INITIAL SUBAREA UNIFORM
DEVELOPMENT IS APARTMENT

TC = $K * [(LENGTH^{**3}) / (ELEVATION CHANGE)]^{** .2}$
 INITIAL SUBAREA FLOW-LENGTH(FEET) = 124.00
 UPSTREAM ELEVATION(FEET) = 879.50
 DOWNSTREAM ELEVATION(FEET) = 877.89
 ELEVATION DIFFERENCE(FEET) = 1.61
 TC = $0.323 * [(124.00^{**3}) / (1.61)]^{** .2} = 5.290$
 10 YEAR RAINFALL INTENSITY(INCH/HOUR) = 3.066
 APARTMENT DEVELOPMENT RUNOFF COEFFICIENT = .8706
 SOIL CLASSIFICATION IS "C"
 SUBAREA RUNOFF(CFS) = 0.99
 TOTAL AREA(ACRES) = 0.37 TOTAL RUNOFF(CFS) = 0.99

FLOW PROCESS FROM NODE 2.00 TO NODE 2.00 IS CODE = 10

>>>>MAIN-STREAM MEMORY COPIED ONTO MEMORY BANK # 1 <<<<<

FLOW PROCESS FROM NODE 2.00 TO NODE 2.00 IS CODE = 13

>>>>CLEAR THE MAIN-STREAM MEMORY<<<<<

FLOW PROCESS FROM NODE 3.00 TO NODE 4.00 IS CODE = 21

>>>>RATIONAL METHOD INITIAL SUBAREA ANALYSIS<<<<<

=====

ASSUMED INITIAL SUBAREA UNIFORM
DEVELOPMENT IS APARTMENT

TC = $K * [(LENGTH^{**3}) / (ELEVATION CHANGE)]^{** .2}$
 INITIAL SUBAREA FLOW-LENGTH(FEET) = 93.44
 UPSTREAM ELEVATION(FEET) = 15.00
 DOWNSTREAM ELEVATION(FEET) = 13.00
 ELEVATION DIFFERENCE(FEET) = 2.00
 TC = $0.323 * [(93.44^{**3}) / (2.00)]^{** .2} = 4.275$

COMPUTED TIME OF CONCENTRATION INCREASED TO 5 MIN.

10 YEAR RAINFALL INTENSITY(INCH/HOUR) = 3.163

APARTMENT DEVELOPMENT RUNOFF COEFFICIENT = .8713

SOIL CLASSIFICATION IS "C"

SUBAREA RUNOFF(CFS) = 0.67

TOTAL AREA(ACRES) = 0.24 TOTAL RUNOFF(CFS) = 0.67

FLOW PROCESS FROM NODE 4.00 TO NODE 4.10 IS CODE = 41

>>>>COMPUTE PIPE-FLOW TRAVEL TIME THRU SUBAREA<<<<<
>>>>USING USER-SPECIFIED PIPESIZE (EXISTING ELEMENT)<<<<<

=====

REPRESENTATIVE SLOPE = 0.0100
FLOW LENGTH(FEET) = 59.80 MANNING'S N = 0.009
DEPTH OF FLOW IN 6.0 INCH PIPE IS 4.2 INCHES
PIPE-FLOW VELOCITY(FEET/SEC.) = 4.51
GIVEN PIPE DIAMETER(INCH) = 6.00 NUMBER OF PIPES = 1
PIPE-FLOW(CFS) = 0.67
PIPE TRAVEL TIME(MIN.) = 0.22 Tc(MIN.) = 5.22
LONGEST FLOWPATH FROM NODE 3.00 TO NODE 4.10 = 153.24 FEET.

FLOW PROCESS FROM NODE 4.10 TO NODE 5.00 IS CODE = 41

>>>>COMPUTE PIPE-FLOW TRAVEL TIME THRU SUBAREA<<<<<
>>>>USING USER-SPECIFIED PIPESIZE (EXISTING ELEMENT)<<<<<

=====

REPRESENTATIVE SLOPE = 0.0100
FLOW LENGTH(FEET) = 13.79 MANNING'S N = 0.009
DEPTH OF FLOW IN 8.0 INCH PIPE IS 3.5 INCHES
PIPE-FLOW VELOCITY(FEET/SEC.) = 4.59
GIVEN PIPE DIAMETER(INCH) = 8.00 NUMBER OF PIPES = 1
PIPE-FLOW(CFS) = 0.67
PIPE TRAVEL TIME(MIN.) = 0.05 Tc(MIN.) = 5.27
LONGEST FLOWPATH FROM NODE 3.00 TO NODE 5.00 = 167.03 FEET.

FLOW PROCESS FROM NODE 5.00 TO NODE 5.00 IS CODE = 10

>>>>MAIN-STREAM MEMORY COPIED ONTO MEMORY BANK # 2 <<<<<

FLOW PROCESS FROM NODE 5.00 TO NODE 5.00 IS CODE = 13

>>>>CLEAR THE MAIN-STREAM MEMORY<<<<<

FLOW PROCESS FROM NODE 6.00 TO NODE 7.00 IS CODE = 21

>>>>RATIONAL METHOD INITIAL SUBAREA ANALYSIS<<<<<

=====

ASSUMED INITIAL SUBAREA UNIFORM
DEVELOPMENT IS APARTMENT

TC = $K * [(LENGTH^{**3}) / (ELEVATION CHANGE)]^{**0.2}$
INITIAL SUBAREA FLOW-LENGTH(FEET) = 94.00
UPSTREAM ELEVATION(FEET) = 15.00
DOWNSTREAM ELEVATION(FEET) = 13.00
ELEVATION DIFFERENCE(FEET) = 2.00
TC = $0.323 * [(94.00^{**3}) / (2.00)]^{**0.2} = 4.290$
COMPUTED TIME OF CONCENTRATION INCREASED TO 5 MIN.
10 YEAR RAINFALL INTENSITY(INCH/HOUR) = 3.163
APARTMENT DEVELOPMENT RUNOFF COEFFICIENT = .8713
SOIL CLASSIFICATION IS "C"
SUBAREA RUNOFF(CFS) = 0.55
TOTAL AREA(ACRES) = 0.20 TOTAL RUNOFF(CFS) = 0.55

FLOW PROCESS FROM NODE 7.00 TO NODE 5.00 IS CODE = 41

>>>>COMPUTE PIPE-FLOW TRAVEL TIME THRU SUBAREA<<<<<
>>>>USING USER-SPECIFIED PIPESIZE (EXISTING ELEMENT)<<<<<

=====

REPRESENTATIVE SLOPE = 0.0100
FLOW LENGTH(FEET) = 12.57 MANNING'S N = 0.009
ASSUME FULL-FLOWING PIPELINE
PIPE-FLOW VELOCITY(FEET/SEC.) = 6.35
PIPE FLOW VELOCITY = (TOTAL FLOW)/(PIPE CROSS SECTION AREA)
GIVEN PIPE DIAMETER(INCH) = 4.00 NUMBER OF PIPES = 1
PIPE-FLOW(CFS) = 0.55
PIPE TRAVEL TIME(MIN.) = 0.03 Tc(MIN.) = 5.03
LONGEST FLOWPATH FROM NODE 6.00 TO NODE 5.00 = 106.57 FEET.

FLOW PROCESS FROM NODE 5.00 TO NODE 5.00 IS CODE = 11

>>>>CONFLUENCE MEMORY BANK # 2 WITH THE MAIN-STREAM MEMORY<<<<<

=====

** MAIN STREAM CONFLUENCE DATA **

STREAM NUMBER	RUNOFF (CFS)	Tc (MIN.)	INTENSITY (INCH/HOUR)	AREA (ACRE)
1	0.55	5.03	3.151	0.20

LONGEST FLOWPATH FROM NODE 6.00 TO NODE 5.00 = 106.57 FEET.

** MEMORY BANK # 2 CONFLUENCE DATA **

STREAM NUMBER	RUNOFF (CFS)	Tc (MIN.)	INTENSITY (INCH/HOUR)	AREA (ACRE)
---------------	--------------	-----------	-----------------------	-------------

1 0.67 5.27 3.072 0.24
LONGEST FLOWPATH FROM NODE 3.00 TO NODE 5.00 = 167.03 FEET.

** PEAK FLOW RATE TABLE **

STREAM NUMBER	RUNOFF (CFS)	Tc (MIN.)	INTENSITY (INCH/HOUR)
1	1.19	5.03	3.151
2	1.21	5.27	3.072

COMPUTED CONFLUENCE ESTIMATES ARE AS FOLLOWS:

PEAK FLOW RATE(CFS) = 1.21 Tc(MIN.) = 5.27
TOTAL AREA(ACRES) = 0.4

FLOW PROCESS FROM NODE 5.00 TO NODE 5.00 IS CODE = 12

>>>>>CLEAR MEMORY BANK # 2 <<<<<<

FLOW PROCESS FROM NODE 7.10 TO NODE 7.10 IS CODE = 81

>>>>>ADDITION OF SUBAREA TO MAINLINE PEAK FLOW<<<<<<

=====

10 YEAR RAINFALL INTENSITY(INCH/HOUR) = 3.072
UNDEVELOPED WATERSHED RUNOFF COEFFICIENT = .7531
SOIL CLASSIFICATION IS "C"
SUBAREA AREA(ACRES) = 0.10 SUBAREA RUNOFF(CFS) = 0.24
TOTAL AREA(ACRES) = 0.5 TOTAL RUNOFF(CFS) = 1.45
TC(MIN.) = 5.27

FLOW PROCESS FROM NODE 5.00 TO NODE 2.00 IS CODE = 41

>>>>>COMPUTE PIPE-FLOW TRAVEL TIME THRU SUBAREA<<<<<<
>>>>>USING USER-SPECIFIED PIPESIZE (EXISTING ELEMENT)<<<<<<

=====

REPRESENTATIVE SLOPE = 0.0100
FLOW LENGTH(FEET) = 78.38 MANNING'S N = 0.009
DEPTH OF FLOW IN 8.0 INCH PIPE IS 5.7 INCHES
PIPE-FLOW VELOCITY(FEET/SEC.) = 5.47
GIVEN PIPE DIAMETER(INCH) = 8.00 NUMBER OF PIPES = 1
PIPE-FLOW(CFS) = 1.45
PIPE TRAVEL TIME(MIN.) = 0.24 Tc(MIN.) = 5.51
LONGEST FLOWPATH FROM NODE 3.00 TO NODE 2.00 = 245.41 FEET.

FLOW PROCESS FROM NODE 2.00 TO NODE 2.00 IS CODE = 11

>>>>>CONFLUENCE MEMORY BANK # 1 WITH THE MAIN-STREAM MEMORY<<<<<<

=====
** MAIN STREAM CONFLUENCE DATA **

STREAM NUMBER	RUNOFF (CFS)	Tc (MIN.)	INTENSITY (INCH/HOUR)	AREA (ACRE)
1	1.44	5.27	3.072	0.55
2	1.45	5.51	2.998	0.55

LONGEST FLOWPATH FROM NODE 3.00 TO NODE 2.00 = 245.41 FEET.

** MEMORY BANK # 1 CONFLUENCE DATA **

STREAM NUMBER	RUNOFF (CFS)	Tc (MIN.)	INTENSITY (INCH/HOUR)	AREA (ACRE)
1	0.99	5.29	3.066	0.37

LONGEST FLOWPATH FROM NODE 1.00 TO NODE 2.00 = 124.00 FEET.

** PEAK FLOW RATE TABLE **

STREAM NUMBER	RUNOFF (CFS)	Tc (MIN.)	INTENSITY (INCH/HOUR)
1	2.42	5.27	3.072
2	2.42	5.29	3.066
3	2.41	5.51	2.998

COMPUTED CONFLUENCE ESTIMATES ARE AS FOLLOWS:

PEAK FLOW RATE(CFS) = 2.42 Tc(MIN.) = 5.29
TOTAL AREA(ACRES) = 0.9

FLOW PROCESS FROM NODE 2.00 TO NODE 2.00 IS CODE = 12

>>>>>CLEAR MEMORY BANK # 1 <<<<<<
=====

FLOW PROCESS FROM NODE 2.00 TO NODE 8.00 IS CODE = 41

>>>>>COMPUTE PIPE-FLOW TRAVEL TIME THRU SUBAREA<<<<<<
>>>>>USING USER-SPECIFIED PIPESIZE (EXISTING ELEMENT)<<<<<<
=====

REPRESENTATIVE SLOPE = 0.0100
FLOW LENGTH(FEET) = 145.73 MANNING'S N = 0.009
DEPTH OF FLOW IN 10.0 INCH PIPE IS 6.7 INCHES
PIPE-FLOW VELOCITY(FEET/SEC.) = 6.27
GIVEN PIPE DIAMETER(INCH) = 10.00 NUMBER OF PIPES = 1
PIPE-FLOW(CFS) = 2.42
PIPE TRAVEL TIME(MIN.) = 0.39 Tc(MIN.) = 5.68
LONGEST FLOWPATH FROM NODE 3.00 TO NODE 8.00 = 391.14 FEET.

FLOW PROCESS FROM NODE 8.00 TO NODE 8.00 IS CODE = 10

>>>>MAIN-STREAM MEMORY COPIED ONTO MEMORY BANK # 1 <<<<<

FLOW PROCESS FROM NODE 8.00 TO NODE 8.00 IS CODE = 13

>>>>CLEAR THE MAIN-STREAM MEMORY<<<<<

FLOW PROCESS FROM NODE 9.00 TO NODE 10.00 IS CODE = 21

>>>>RATIONAL METHOD INITIAL SUBAREA ANALYSIS<<<<<

ASSUMED INITIAL SUBAREA UNIFORM
DEVELOPMENT IS APARTMENT

$TC = K * [(LENGTH^{**3}) / (ELEVATION CHANGE)]^{**0.2}$
INITIAL SUBAREA FLOW-LENGTH(FEET) = 71.61
UPSTREAM ELEVATION(FEET) = 15.00
DOWNSTREAM ELEVATION(FEET) = 13.00
ELEVATION DIFFERENCE(FEET) = 2.00
 $TC = 0.323 * [(71.61^{**3}) / (2.00)]^{**0.2} = 3.644$
COMPUTED TIME OF CONCENTRATION INCREASED TO 5 MIN.
10 YEAR RAINFALL INTENSITY(INCH/HOUR) = 3.163
APARTMENT DEVELOPMENT RUNOFF COEFFICIENT = .8713
SOIL CLASSIFICATION IS "C"
SUBAREA RUNOFF(CFS) = 0.56
TOTAL AREA(ACRES) = 0.20 TOTAL RUNOFF(CFS) = 0.56

FLOW PROCESS FROM NODE 10.00 TO NODE 10.10 IS CODE = 41

>>>>COMPUTE PIPE-FLOW TRAVEL TIME THRU SUBAREA<<<<<
>>>>USING USER-SPECIFIED PIPESIZE (EXISTING ELEMENT)<<<<<

REPRESENTATIVE SLOPE = 0.0100
FLOW LENGTH(FEET) = 45.35 MANNING'S N = 0.009
ASSUME FULL-FLOWING PIPELINE
PIPE-FLOW VELOCITY(FEET/SEC.) = 6.41
PIPE FLOW VELOCITY = (TOTAL FLOW)/(PIPE CROSS SECTION AREA)
GIVEN PIPE DIAMETER(INCH) = 4.00 NUMBER OF PIPES = 1
PIPE-FLOW(CFS) = 0.56
PIPE TRAVEL TIME(MIN.) = 0.12 Tc(MIN.) = 5.12
LONGEST FLOWPATH FROM NODE 9.00 TO NODE 10.10 = 116.96 FEET.

FLOW PROCESS FROM NODE 10.10 TO NODE 10.20 IS CODE = 41

>>>>COMPUTE PIPE-FLOW TRAVEL TIME THRU SUBAREA<<<<<
>>>>USING USER-SPECIFIED PIPESIZE (EXISTING ELEMENT)<<<<<

=====

REPRESENTATIVE SLOPE = 0.0100
FLOW LENGTH(FEET) = 37.68 MANNING'S N = 0.009
DEPTH OF FLOW IN 6.0 INCH PIPE IS 3.7 INCHES
PIPE-FLOW VELOCITY(FEET/SEC.) = 4.34
GIVEN PIPE DIAMETER(INCH) = 6.00 NUMBER OF PIPES = 1
PIPE-FLOW(CFS) = 0.56
PIPE TRAVEL TIME(MIN.) = 0.14 Tc(MIN.) = 5.26
LONGEST FLOWPATH FROM NODE 9.00 TO NODE 10.20 = 154.64 FEET.

FLOW PROCESS FROM NODE 10.20 TO NODE 10.20 IS CODE = 10

>>>>MAIN-STREAM MEMORY COPIED ONTO MEMORY BANK # 3 <<<<<

FLOW PROCESS FROM NODE 10.20 TO NODE 10.20 IS CODE = 13

>>>>CLEAR THE MAIN-STREAM MEMORY<<<<<

FLOW PROCESS FROM NODE 10.30 TO NODE 10.40 IS CODE = 21

>>>>RATIONAL METHOD INITIAL SUBAREA ANALYSIS<<<<<

=====

ASSUMED INITIAL SUBAREA UNIFORM
DEVELOPMENT IS: UNDEVELOPED WITH GOOD COVER
 $TC = K * [(LENGTH^{**3}) / (ELEVATION CHANGE)]^{**0.2}$
INITIAL SUBAREA FLOW-LENGTH(FEET) = 17.00
UPSTREAM ELEVATION(FEET) = 878.70
DOWNSTREAM ELEVATION(FEET) = 878.32
ELEVATION DIFFERENCE(FEET) = 0.38
 $TC = 0.937 * [(17.00^{**3}) / (0.38)]^{**0.2} = 6.226$
10 YEAR RAINFALL INTENSITY(INCH/HOUR) = 2.804
UNDEVELOPED WATERSHED RUNOFF COEFFICIENT = .7416
SOIL CLASSIFICATION IS "C"
SUBAREA RUNOFF(CFS) = 0.17
TOTAL AREA(ACRES) = 0.08 TOTAL RUNOFF(CFS) = 0.17

FLOW PROCESS FROM NODE 10.40 TO NODE 10.20 IS CODE = 41

>>>>COMPUTE PIPE-FLOW TRAVEL TIME THRU SUBAREA<<<<<
>>>>USING USER-SPECIFIED PIPESIZE (EXISTING ELEMENT)<<<<<

=====

REPRESENTATIVE SLOPE = 0.0100
FLOW LENGTH(FEET) = 8.88 MANNING'S N = 0.009
DEPTH OF FLOW IN 4.0 INCH PIPE IS 2.4 INCHES

PIPE-FLOW VELOCITY(FEET/SEC.) = 3.20
GIVEN PIPE DIAMETER(INCH) = 4.00 NUMBER OF PIPES = 1
PIPE-FLOW(CFS) = 0.17
PIPE TRAVEL TIME(MIN.) = 0.05 Tc(MIN.) = 6.27
LONGEST FLOWPATH FROM NODE 10.30 TO NODE 10.20 = 25.88 FEET.

FLOW PROCESS FROM NODE 10.20 TO NODE 10.20 IS CODE = 11

>>>>CONFLUENCE MEMORY BANK # 3 WITH THE MAIN-STREAM MEMORY<<<<<

** MAIN STREAM CONFLUENCE DATA **

STREAM NUMBER	RUNOFF (CFS)	Tc (MIN.)	INTENSITY (INCH/HOUR)	AREA (ACRE)
1	0.17	6.27	2.792	0.08

LONGEST FLOWPATH FROM NODE 10.30 TO NODE 10.20 = 25.88 FEET.

** MEMORY BANK # 3 CONFLUENCE DATA **

STREAM NUMBER	RUNOFF (CFS)	Tc (MIN.)	INTENSITY (INCH/HOUR)	AREA (ACRE)
1	0.56	5.26	3.075	0.20

LONGEST FLOWPATH FROM NODE 9.00 TO NODE 10.20 = 154.64 FEET.

** PEAK FLOW RATE TABLE **

STREAM NUMBER	RUNOFF (CFS)	Tc (MIN.)	INTENSITY (INCH/HOUR)
1	0.71	5.26	3.075
2	0.68	6.27	2.792

COMPUTED CONFLUENCE ESTIMATES ARE AS FOLLOWS:

PEAK FLOW RATE(CFS) = 0.71 Tc(MIN.) = 5.26
TOTAL AREA(ACRES) = 0.3

FLOW PROCESS FROM NODE 10.20 TO NODE 10.20 IS CODE = 12

>>>>CLEAR MEMORY BANK # 3 <<<<<

FLOW PROCESS FROM NODE 10.20 TO NODE 10.50 IS CODE = 41

>>>>COMPUTE PIPE-FLOW TRAVEL TIME THRU SUBAREA<<<<<
>>>>USING USER-SPECIFIED PIPESIZE (EXISTING ELEMENT)<<<<<

REPRESENTATIVE SLOPE = 0.0100
FLOW LENGTH(FEET) = 131.52 MANNING'S N = 0.009
DEPTH OF FLOW IN 6.0 INCH PIPE IS 4.4 INCHES
PIPE-FLOW VELOCITY(FEET/SEC.) = 4.54

GIVEN PIPE DIAMETER(INCH) = 6.00 NUMBER OF PIPES = 1
 PIPE-FLOW(CFS) = 0.71
 PIPE TRAVEL TIME(MIN.) = 0.48 Tc(MIN.) = 5.75
 LONGEST FLOWPATH FROM NODE 9.00 TO NODE 10.50 = 286.16 FEET.

FLOW PROCESS FROM NODE 10.50 TO NODE 10.50 IS CODE = 81

>>>>ADDITION OF SUBAREA TO MAINLINE PEAK FLOW<<<<<

=====

10 YEAR RAINFALL INTENSITY(INCH/HOUR) = 2.930
 UNDEVELOPED WATERSHED RUNOFF COEFFICIENT = .7472
 SOIL CLASSIFICATION IS "C"
 SUBAREA AREA(ACRES) = 0.10 SUBAREA RUNOFF(CFS) = 0.22
 TOTAL AREA(ACRES) = 0.4 TOTAL RUNOFF(CFS) = 0.92
 TC(MIN.) = 5.75

FLOW PROCESS FROM NODE 10.50 TO NODE 8.00 IS CODE = 41

>>>>COMPUTE PIPE-FLOW TRAVEL TIME THRU SUBAREA<<<<<
 >>>>USING USER-SPECIFIED PIPESIZE (EXISTING ELEMENT)<<<<<

=====

REPRESENTATIVE SLOPE = 0.0100
 FLOW LENGTH(FEET) = 137.41 MANNING'S N = 0.009
 DEPTH OF FLOW IN 8.0 INCH PIPE IS 4.2 INCHES
 PIPE-FLOW VELOCITY(FEET/SEC.) = 4.99
 GIVEN PIPE DIAMETER(INCH) = 8.00 NUMBER OF PIPES = 1
 PIPE-FLOW(CFS) = 0.92
 PIPE TRAVEL TIME(MIN.) = 0.46 Tc(MIN.) = 6.20
 LONGEST FLOWPATH FROM NODE 9.00 TO NODE 8.00 = 423.57 FEET.

FLOW PROCESS FROM NODE 8.00 TO NODE 8.00 IS CODE = 11

>>>>CONFLUENCE MEMORY BANK # 1 WITH THE MAIN-STREAM MEMORY<<<<<

** MAIN STREAM CONFLUENCE DATA **

STREAM NUMBER	RUNOFF (CFS)	Tc (MIN.)	INTENSITY (INCH/HOUR)	AREA (ACRE)
1	0.92	6.20	2.809	0.39
2	0.88	7.22	2.584	0.39

LONGEST FLOWPATH FROM NODE 9.00 TO NODE 8.00 = 423.57 FEET.

** MEMORY BANK # 1 CONFLUENCE DATA **

STREAM NUMBER	RUNOFF (CFS)	Tc (MIN.)	INTENSITY (INCH/HOUR)	AREA (ACRE)
1	2.42	5.66	2.955	0.92
2	2.42	5.68	2.949	0.92

3 2.41 5.90 2.889 0.92
LONGEST FLOWPATH FROM NODE 3.00 TO NODE 8.00 = 391.14 FEET.

** PEAK FLOW RATE TABLE **

STREAM NUMBER	RUNOFF (CFS)	Tc (MIN.)	INTENSITY (INCH/HOUR)
1	3.26	5.66	2.955
2	3.27	5.68	2.949
3	3.29	5.90	2.889
4	3.27	6.20	2.809
5	3.04	7.22	2.584

COMPUTED CONFLUENCE ESTIMATES ARE AS FOLLOWS:

PEAK FLOW RATE(CFS) = 3.29 Tc(MIN.) = 5.90
TOTAL AREA(ACRES) = 1.3

FLOW PROCESS FROM NODE 8.00 TO NODE 8.00 IS CODE = 12

>>>>CLEAR MEMORY BANK # 1 <<<<<<

FLOW PROCESS FROM NODE 8.00 TO NODE 13.00 IS CODE = 41

>>>>COMPUTE PIPE-FLOW TRAVEL TIME THRU SUBAREA<<<<<<
>>>>USING USER-SPECIFIED PIPESIZE (EXISTING ELEMENT)<<<<<<

REPRESENTATIVE SLOPE = 0.0100
FLOW LENGTH(FEET) = 38.12 MANNING'S N = 0.009
ASSUME FULL-FLOWING PIPELINE
PIPE-FLOW VELOCITY(FEET/SEC.) = 6.03
PIPE FLOW VELOCITY = (TOTAL FLOW)/(PIPE CROSS SECTION AREA)
GIVEN PIPE DIAMETER(INCH) = 10.00 NUMBER OF PIPES = 1
PIPE-FLOW(CFS) = 3.29
PIPE TRAVEL TIME(MIN.) = 0.11 Tc(MIN.) = 6.00
LONGEST FLOWPATH FROM NODE 9.00 TO NODE 13.00 = 461.69 FEET.

FLOW PROCESS FROM NODE 13.00 TO NODE 13.00 IS CODE = 10

>>>>MAIN-STREAM MEMORY COPIED ONTO MEMORY BANK # 1 <<<<<<

FLOW PROCESS FROM NODE 13.00 TO NODE 13.00 IS CODE = 13

>>>>CLEAR THE MAIN-STREAM MEMORY<<<<<<

FLOW PROCESS FROM NODE 11.00 TO NODE 12.00 IS CODE = 21

>>>>RATIONAL METHOD INITIAL SUBAREA ANALYSIS<<<<<

ASSUMED INITIAL SUBAREA UNIFORM DEVELOPMENT IS APARTMENT

TC = K*[(LENGTH**3)/(ELEVATION CHANGE)]**.2
INITIAL SUBAREA FLOW-LENGTH(FEET) = 36.94
UPSTREAM ELEVATION(FEET) = 15.00
DOWNSTREAM ELEVATION(FEET) = 13.00
ELEVATION DIFFERENCE(FEET) = 2.00
TC = 0.323*[(36.94**3)/(2.00)]**.2 = 2.450
COMPUTED TIME OF CONCENTRATION INCREASED TO 5 MIN.
10 YEAR RAINFALL INTENSITY(INCH/HOUR) = 3.163
APARTMENT DEVELOPMENT RUNOFF COEFFICIENT = .8713
SOIL CLASSIFICATION IS "C"
SUBAREA RUNOFF(CFS) = 0.14
TOTAL AREA(ACRES) = 0.05 TOTAL RUNOFF(CFS) = 0.14

FLOW PROCESS FROM NODE 12.00 TO NODE 13.00 IS CODE = 41

>>>>COMPUTE PIPE-FLOW TRAVEL TIME THRU SUBAREA<<<<<
>>>>USING USER-SPECIFIED PIPESIZE (EXISTING ELEMENT)<<<<<

REPRESENTATIVE SLOPE = 0.0100
FLOW LENGTH(FEET) = 41.32 MANNING'S N = 0.009
DEPTH OF FLOW IN 4.0 INCH PIPE IS 2.0 INCHES
PIPE-FLOW VELOCITY(FEET/SEC.) = 3.07
GIVEN PIPE DIAMETER(INCH) = 4.00 NUMBER OF PIPES = 1
PIPE-FLOW(CFS) = 0.14
PIPE TRAVEL TIME(MIN.) = 0.22 Tc(MIN.) = 5.22
LONGEST FLOWPATH FROM NODE 11.00 TO NODE 13.00 = 78.26 FEET.

FLOW PROCESS FROM NODE 13.00 TO NODE 13.00 IS CODE = 11

>>>>CONFLUENCE MEMORY BANK # 1 WITH THE MAIN-STREAM MEMORY<<<<<

** MAIN STREAM CONFLUENCE DATA **

STREAM RUNOFF Tc INTENSITY AREA
NUMBER (CFS) (MIN.) (INCH/HOUR) (ACRE)
1 0.14 5.22 3.087 0.05
LONGEST FLOWPATH FROM NODE 11.00 TO NODE 13.00 = 78.26 FEET.

** MEMORY BANK # 1 CONFLUENCE DATA **

STREAM RUNOFF Tc INTENSITY AREA
NUMBER (CFS) (MIN.) (INCH/HOUR) (ACRE)

1	3.26	5.77	2.925	1.30
2	3.27	5.78	2.920	1.30
3	3.29	6.00	2.861	1.30
4	3.27	6.31	2.783	1.30
5	3.04	7.32	2.565	1.30

LONGEST FLOWPATH FROM NODE 9.00 TO NODE 13.00 = 461.69 FEET.

** PEAK FLOW RATE TABLE **

STREAM NUMBER	RUNOFF (CFS)	Tc (MIN.)	INTENSITY (INCH/HOUR)
1	3.10	5.22	3.087
2	3.39	5.77	2.925
3	3.40	5.78	2.920
4	3.42	6.00	2.861
5	3.39	6.31	2.783
6	3.15	7.32	2.565

COMPUTED CONFLUENCE ESTIMATES ARE AS FOLLOWS:

PEAK FLOW RATE(CFS) = 3.42 Tc(MIN.) = 6.00
TOTAL AREA(ACRES) = 1.4

FLOW PROCESS FROM NODE 13.00 TO NODE 13.00 IS CODE = 12

>>>>CLEAR MEMORY BANK # 1 <<<<<

FLOW PROCESS FROM NODE 13.00 TO NODE 13.00 IS CODE = 10

>>>>MAIN-STREAM MEMORY COPIED ONTO MEMORY BANK # 1 <<<<<

FLOW PROCESS FROM NODE 13.00 TO NODE 13.00 IS CODE = 13

>>>>CLEAR THE MAIN-STREAM MEMORY<<<<<

FLOW PROCESS FROM NODE 14.00 TO NODE 15.00 IS CODE = 21

>>>>RATIONAL METHOD INITIAL SUBAREA ANALYSIS<<<<<

=====

ASSUMED INITIAL SUBAREA UNIFORM
DEVELOPMENT IS APARTMENT

TC = K*[(LENGTH**3)/(ELEVATION CHANGE)]**.2
INITIAL SUBAREA FLOW-LENGTH(FEET) = 282.36
UPSTREAM ELEVATION(FEET) = 881.50
DOWNSTREAM ELEVATION(FEET) = 877.80

ELEVATION DIFFERENCE(FEET) = 3.70
 $TC = 0.323 * [(282.36^{**3}) / (3.70)]^{**0.2} = 7.339$
 10 YEAR RAINFALL INTENSITY(INCH/HOUR) = 2.562
 APARTMENT DEVELOPMENT RUNOFF COEFFICIENT = .8659
 SOIL CLASSIFICATION IS "C"
 SUBAREA RUNOFF(CFS) = 2.93
 TOTAL AREA(ACRES) = 1.32 TOTAL RUNOFF(CFS) = 2.93

 FLOW PROCESS FROM NODE 15.00 TO NODE 15.00 IS CODE = 11

 >>>>CONFLUENCE MEMORY BANK # 1 WITH THE MAIN-STREAM MEMORY<<<<<
 =====

** MAIN STREAM CONFLUENCE DATA **

STREAM NUMBER	RUNOFF (CFS)	Tc (MIN.)	INTENSITY (INCH/HOUR)	AREA (ACRE)
1	2.93	7.34	2.562	1.32

LONGEST FLOWPATH FROM NODE 14.00 TO NODE 15.00 = 282.36 FEET.

** MEMORY BANK # 1 CONFLUENCE DATA **

STREAM NUMBER	RUNOFF (CFS)	Tc (MIN.)	INTENSITY (INCH/HOUR)	AREA (ACRE)
1	3.10	5.22	3.087	1.35
2	3.39	5.77	2.925	1.35
3	3.40	5.78	2.920	1.35
4	3.42	6.00	2.861	1.35
5	3.39	6.31	2.783	1.35
6	3.15	7.32	2.565	1.35

LONGEST FLOWPATH FROM NODE 9.00 TO NODE 15.00 = 461.69 FEET.

** PEAK FLOW RATE TABLE **

STREAM NUMBER	RUNOFF (CFS)	Tc (MIN.)	INTENSITY (INCH/HOUR)
1	5.18	5.22	3.087
2	5.70	5.77	2.925
3	5.71	5.78	2.920
4	5.82	6.00	2.861
5	5.92	6.31	2.783
6	6.08	7.32	2.565
7	6.08	7.34	2.562

COMPUTED CONFLUENCE ESTIMATES ARE AS FOLLOWS:

PEAK FLOW RATE(CFS) = 6.08 Tc(MIN.) = 7.34
 TOTAL AREA(ACRES) = 2.7

 FLOW PROCESS FROM NODE 15.00 TO NODE 15.00 IS CODE = 12

 >>>>CLEAR MEMORY BANK # 1 <<<<<

=====

FLOW PROCESS FROM NODE 15.00 TO NODE 15.00 IS CODE = 10

>>>>MAIN-STREAM MEMORY COPIED ONTO MEMORY BANK # 1 <<<<<

=====

FLOW PROCESS FROM NODE 15.00 TO NODE 15.00 IS CODE = 13

>>>>CLEAR THE MAIN-STREAM MEMORY<<<<<

=====

FLOW PROCESS FROM NODE 16.00 TO NODE 17.00 IS CODE = 21

>>>>RATIONAL METHOD INITIAL SUBAREA ANALYSIS<<<<<

=====

ASSUMED INITIAL SUBAREA UNIFORM
DEVELOPMENT IS APARTMENT

TC = K*[(LENGTH**3)/(ELEVATION CHANGE)]**.2
INITIAL SUBAREA FLOW-LENGTH(FEET) = 74.23
UPSTREAM ELEVATION(FEET) = 15.00
DOWNSTREAM ELEVATION(FEET) = 13.00
ELEVATION DIFFERENCE(FEET) = 2.00
TC = 0.323*[(74.23**3)/(2.00)]**.2 = 3.723
COMPUTED TIME OF CONCENTRATION INCREASED TO 5 MIN.
10 YEAR RAINFALL INTENSITY(INCH/HOUR) = 3.163
APARTMENT DEVELOPMENT RUNOFF COEFFICIENT = .8713
SOIL CLASSIFICATION IS "C"
SUBAREA RUNOFF(CFS) = 0.80
TOTAL AREA(ACRES) = 0.29 TOTAL RUNOFF(CFS) = 0.80

FLOW PROCESS FROM NODE 17.00 TO NODE 17.10 IS CODE = 41

>>>>COMPUTE PIPE-FLOW TRAVEL TIME THRU SUBAREA<<<<<
>>>>USING USER-SPECIFIED PIPESIZE (EXISTING ELEMENT)<<<<<

=====

REPRESENTATIVE SLOPE = 0.0100
FLOW LENGTH(FEET) = 15.20 MANNING'S N = 0.009
ASSUME FULL-FLOWING PIPELINE
PIPE-FLOW VELOCITY(FEET/SEC.) = 9.13
PIPE FLOW VELOCITY = (TOTAL FLOW)/(PIPE CROSS SECTION AREA)
GIVEN PIPE DIAMETER(INCH) = 4.00 NUMBER OF PIPES = 1
PIPE-FLOW(CFS) = 0.80
PIPE TRAVEL TIME(MIN.) = 0.03 Tc(MIN.) = 5.03
LONGEST FLOWPATH FROM NODE 16.00 TO NODE 17.10 = 89.43 FEET.

FLOW PROCESS FROM NODE 17.10 TO NODE 18.00 IS CODE = 41

>>>>COMPUTE PIPE-FLOW TRAVEL TIME THRU SUBAREA<<<<<
>>>>USING USER-SPECIFIED PIPESIZE (EXISTING ELEMENT)<<<<<

=====

REPRESENTATIVE SLOPE =	0.0100		
FLOW LENGTH(FEET) =	164.51	MANNING'S N =	0.009
DEPTH OF FLOW IN	8.0 INCH PIPE IS	3.8 INCHES	
PIPE-FLOW VELOCITY(FEET/SEC.) =	4.81		
GIVEN PIPE DIAMETER(INCH) =	8.00	NUMBER OF PIPES =	1
PIPE-FLOW(CFS) =	0.80		
PIPE TRAVEL TIME(MIN.) =	0.57	Tc(MIN.) =	5.60
LONGEST FLOWPATH FROM NODE	16.00 TO NODE	18.00 =	253.94 FEET.

FLOW PROCESS FROM NODE 18.00 TO NODE 18.00 IS CODE = 10

>>>>MAIN-STREAM MEMORY COPIED ONTO MEMORY BANK # 2 <<<<<

FLOW PROCESS FROM NODE 18.00 TO NODE 18.00 IS CODE = 13

>>>>CLEAR THE MAIN-STREAM MEMORY<<<<<

FLOW PROCESS FROM NODE 19.00 TO NODE 20.00 IS CODE = 21

>>>>RATIONAL METHOD INITIAL SUBAREA ANALYSIS<<<<<

=====

ASSUMED INITIAL SUBAREA UNIFORM
DEVELOPMENT IS APARTMENT

TC = K*[(LENGTH**3)/(ELEVATION CHANGE)]**.2			
INITIAL SUBAREA FLOW-LENGTH(FEET) =	147.00		
UPSTREAM ELEVATION(FEET) =	881.00		
DOWNSTREAM ELEVATION(FEET) =	878.08		
ELEVATION DIFFERENCE(FEET) =	2.92		
TC = 0.323*[(147.00**3)/(2.92)]**.2 =	5.201		
10 YEAR RAINFALL INTENSITY(INCH/HOUR) =	3.095		
APARTMENT DEVELOPMENT RUNOFF COEFFICIENT =	.8708		
SOIL CLASSIFICATION IS "C"			
SUBAREA RUNOFF(CFS) =	0.85		
TOTAL AREA(ACRES) =	0.31	TOTAL RUNOFF(CFS) =	0.85

FLOW PROCESS FROM NODE 20.00 TO NODE 20.00 IS CODE = 11

>>>>CONFLUENCE MEMORY BANK # 2 WITH THE MAIN-STREAM MEMORY<<<<<

=====
** MAIN STREAM CONFLUENCE DATA **

STREAM NUMBER	RUNOFF (CFS)	Tc (MIN.)	INTENSITY (INCH/HOUR)	AREA (ACRE)	
1	0.85	5.20	3.095	0.31	
LONGEST FLOWPATH FROM NODE			19.00 TO NODE	20.00 =	147.00 FEET.

** MEMORY BANK # 2 CONFLUENCE DATA **

STREAM NUMBER	RUNOFF (CFS)	Tc (MIN.)	INTENSITY (INCH/HOUR)	AREA (ACRE)	
1	0.80	5.60	2.972	0.29	
LONGEST FLOWPATH FROM NODE			16.00 TO NODE	20.00 =	253.94 FEET.

** PEAK FLOW RATE TABLE **

STREAM NUMBER	RUNOFF (CFS)	Tc (MIN.)	INTENSITY (INCH/HOUR)
1	1.59	5.20	3.095
2	1.61	5.60	2.972

COMPUTED CONFLUENCE ESTIMATES ARE AS FOLLOWS:

PEAK FLOW RATE(CFS) = 1.61 Tc(MIN.) = 5.60
TOTAL AREA(ACRES) = 0.6

FLOW PROCESS FROM NODE 20.00 TO NODE 20.00 IS CODE = 12

>>>>CLEAR MEMORY BANK # 2 <<<<<

FLOW PROCESS FROM NODE 20.00 TO NODE 21.00 IS CODE = 41

>>>>COMPUTE PIPE-FLOW TRAVEL TIME THRU SUBAREA<<<<<
>>>>USING USER-SPECIFIED PIPESIZE (EXISTING ELEMENT)<<<<<

REPRESENTATIVE SLOPE = 0.0100
FLOW LENGTH(FEET) = 35.92 MANNING'S N = 0.009
ASSUME FULL-FLOWING PIPELINE
PIPE-FLOW VELOCITY(FEET/SEC.) = 8.21
PIPE FLOW VELOCITY = (TOTAL FLOW)/(PIPE CROSS SECTION AREA)
GIVEN PIPE DIAMETER(INCH) = 6.00 NUMBER OF PIPES = 1
PIPE-FLOW(CFS) = 1.61
PIPE TRAVEL TIME(MIN.) = 0.07 Tc(MIN.) = 5.67
LONGEST FLOWPATH FROM NODE 16.00 TO NODE 21.00 = 289.86 FEET.

FLOW PROCESS FROM NODE 21.00 TO NODE 21.00 IS CODE = 10

>>>>MAIN-STREAM MEMORY COPIED ONTO MEMORY BANK # 2 <<<<<

FLOW PROCESS FROM NODE 21.00 TO NODE 21.00 IS CODE = 13

>>>>CLEAR THE MAIN-STREAM MEMORY<<<<<

FLOW PROCESS FROM NODE 22.00 TO NODE 23.00 IS CODE = 21

>>>>RATIONAL METHOD INITIAL SUBAREA ANALYSIS<<<<<

ASSUMED INITIAL SUBAREA UNIFORM
DEVELOPMENT IS: UNDEVELOPED WITH GOOD COVER
TC = $K * [(LENGTH^{**3}) / (ELEVATION CHANGE)]^{**0.2}$
INITIAL SUBAREA FLOW-LENGTH(FEET) = 77.86
UPSTREAM ELEVATION(FEET) = 881.47
DOWNSTREAM ELEVATION(FEET) = 880.67
ELEVATION DIFFERENCE(FEET) = 0.80
TC = $0.937 * [(77.86^{**3}) / (0.80)]^{**0.2} = 13.369$
10 YEAR RAINFALL INTENSITY(INCH/HOUR) = 1.843
UNDEVELOPED WATERSHED RUNOFF COEFFICIENT = .6792
SOIL CLASSIFICATION IS "C"
SUBAREA RUNOFF(CFS) = 0.13
TOTAL AREA(ACRES) = 0.10 TOTAL RUNOFF(CFS) = 0.13

FLOW PROCESS FROM NODE 23.00 TO NODE 21.00 IS CODE = 41

>>>>COMPUTE PIPE-FLOW TRAVEL TIME THRU SUBAREA<<<<<
>>>>USING USER-SPECIFIED PIPESIZE (EXISTING ELEMENT)<<<<<

REPRESENTATIVE SLOPE = 0.0100
FLOW LENGTH(FEET) = 107.21 MANNING'S N = 0.009
DEPTH OF FLOW IN 6.0 INCH PIPE IS 1.6 INCHES
PIPE-FLOW VELOCITY(FEET/SEC.) = 2.93
GIVEN PIPE DIAMETER(INCH) = 6.00 NUMBER OF PIPES = 1
PIPE-FLOW(CFS) = 0.13
PIPE TRAVEL TIME(MIN.) = 0.61 Tc(MIN.) = 13.98
LONGEST FLOWPATH FROM NODE 22.00 TO NODE 21.00 = 185.07 FEET.

FLOW PROCESS FROM NODE 21.00 TO NODE 21.00 IS CODE = 11

>>>>CONFLUENCE MEMORY BANK # 2 WITH THE MAIN-STREAM MEMORY<<<<<

** MAIN STREAM CONFLUENCE DATA **
STREAM RUNOFF Tc INTENSITY AREA

NUMBER	(CFS)	(MIN.)	(INCH/HOUR)	(ACRE)
1	0.13	13.98	1.798	0.10

LONGEST FLOWPATH FROM NODE 22.00 TO NODE 21.00 = 185.07 FEET.

** MEMORY BANK # 2 CONFLUENCE DATA **

STREAM NUMBER	RUNOFF (CFS)	Tc (MIN.)	INTENSITY (INCH/HOUR)	AREA (ACRE)
1	1.59	5.28	3.071	0.60
2	1.61	5.67	2.951	0.60

LONGEST FLOWPATH FROM NODE 16.00 TO NODE 21.00 = 289.86 FEET.

** PEAK FLOW RATE TABLE **

STREAM NUMBER	RUNOFF (CFS)	Tc (MIN.)	INTENSITY (INCH/HOUR)
1	1.64	5.28	3.071
2	1.66	5.67	2.951
3	1.11	13.98	1.798

COMPUTED CONFLUENCE ESTIMATES ARE AS FOLLOWS:

PEAK FLOW RATE(CFS) = 1.66 Tc(MIN.) = 5.67
TOTAL AREA(ACRES) = 0.7

FLOW PROCESS FROM NODE 21.00 TO NODE 21.00 IS CODE = 12

>>>>CLEAR MEMORY BANK # 2 <<<<<

FLOW PROCESS FROM NODE 21.00 TO NODE 24.00 IS CODE = 41

>>>>COMPUTE PIPE-FLOW TRAVEL TIME THRU SUBAREA<<<<<
>>>>USING USER-SPECIFIED PIPESIZE (EXISTING ELEMENT)<<<<<

=====

REPRESENTATIVE SLOPE = 0.0100
FLOW LENGTH(FEET) = 136.64 MANNING'S N = 0.009
ASSUME FULL-FLOWING PIPELINE
PIPE-FLOW VELOCITY(FEET/SEC.) = 8.47
PIPE FLOW VELOCITY = (TOTAL FLOW)/(PIPE CROSS SECTION AREA)
GIVEN PIPE DIAMETER(INCH) = 6.00 NUMBER OF PIPES = 1
PIPE-FLOW(CFS) = 1.66
PIPE TRAVEL TIME(MIN.) = 0.27 Tc(MIN.) = 5.94
LONGEST FLOWPATH FROM NODE 16.00 TO NODE 24.00 = 426.50 FEET.

FLOW PROCESS FROM NODE 24.00 TO NODE 24.00 IS CODE = 11

>>>>CONFLUENCE MEMORY BANK # 1 WITH THE MAIN-STREAM MEMORY<<<<<

=====

** MAIN STREAM CONFLUENCE DATA **

STREAM NUMBER	RUNOFF (CFS)	Tc (MIN.)	INTENSITY (INCH/HOUR)	AREA (ACRE)
1	1.64	5.55	2.987	0.70
2	1.66	5.94	2.877	0.70
3	1.11	14.38	1.770	0.70

LONGEST FLOWPATH FROM NODE 16.00 TO NODE 24.00 = 426.50 FEET.

** MEMORY BANK # 1 CONFLUENCE DATA **

STREAM NUMBER	RUNOFF (CFS)	Tc (MIN.)	INTENSITY (INCH/HOUR)	AREA (ACRE)
1	5.18	5.22	3.087	2.68
2	5.70	5.77	2.925	2.68
3	5.71	5.78	2.920	2.68
4	5.82	6.00	2.861	2.68
5	5.92	6.31	2.783	2.68
6	6.08	7.32	2.565	2.68
7	6.08	7.34	2.562	2.68

LONGEST FLOWPATH FROM NODE 9.00 TO NODE 24.00 = 461.69 FEET.

** PEAK FLOW RATE TABLE **

STREAM NUMBER	RUNOFF (CFS)	Tc (MIN.)	INTENSITY (INCH/HOUR)
1	6.73	5.22	3.087
2	7.12	5.55	2.987
3	7.31	5.77	2.925
4	7.33	5.78	2.920
5	7.42	5.94	2.877
6	7.47	6.00	2.861
7	7.53	6.31	2.783
8	7.56	7.32	2.565
9	7.56	7.34	2.562
10	5.31	14.38	1.770

COMPUTED CONFLUENCE ESTIMATES ARE AS FOLLOWS:

PEAK FLOW RATE(CFS) = 7.56 Tc(MIN.) = 7.34
TOTAL AREA(ACRES) = 3.4

FLOW PROCESS FROM NODE 24.00 TO NODE 24.00 IS CODE = 12

>>>>CLEAR MEMORY BANK # 1 <<<<<

FLOW PROCESS FROM NODE 24.00 TO NODE 25.00 IS CODE = 41

>>>>COMPUTE PIPE-FLOW TRAVEL TIME THRU SUBAREA<<<<<
>>>>USING USER-SPECIFIED PIPESIZE (EXISTING ELEMENT)<<<<<

REPRESENTATIVE SLOPE = 0.0100
FLOW LENGTH(FEET) = 55.93 MANNING'S N = 0.009
ASSUME FULL-FLOWING PIPELINE
PIPE-FLOW VELOCITY(FEET/SEC.) = 38.52
PIPE FLOW VELOCITY = (TOTAL FLOW)/(PIPE CROSS SECTION AREA)
GIVEN PIPE DIAMETER(INCH) = 6.00 NUMBER OF PIPES = 1
PIPE-FLOW(CFS) = 7.56
PIPE TRAVEL TIME(MIN.) = 0.02 Tc(MIN.) = 7.36
LONGEST FLOWPATH FROM NODE 9.00 TO NODE 25.00 = 517.62 FEET.

FLOW PROCESS FROM NODE 26.00 TO NODE 27.00 IS CODE = 41

>>>>COMPUTE PIPE-FLOW TRAVEL TIME THRU SUBAREA<<<<<
>>>>USING USER-SPECIFIED PIPESIZE (EXISTING ELEMENT)<<<<<

=====

REPRESENTATIVE SLOPE = 0.0040
FLOW LENGTH(FEET) = 255.17 MANNING'S N = 0.010
DEPTH OF FLOW IN 18.0 INCH PIPE IS 13.3 INCHES
PIPE-FLOW VELOCITY(FEET/SEC.) = 5.39
GIVEN PIPE DIAMETER(INCH) = 18.00 NUMBER OF PIPES = 1
PIPE-FLOW(CFS) = 7.56
PIPE TRAVEL TIME(MIN.) = 0.79 Tc(MIN.) = 8.15
LONGEST FLOWPATH FROM NODE 9.00 TO NODE 27.00 = 772.79 FEET.

FLOW PROCESS FROM NODE 27.00 TO NODE 27.10 IS CODE = 41

>>>>COMPUTE PIPE-FLOW TRAVEL TIME THRU SUBAREA<<<<<
>>>>USING USER-SPECIFIED PIPESIZE (EXISTING ELEMENT)<<<<<

=====

REPRESENTATIVE SLOPE = 0.0040
FLOW LENGTH(FEET) = 279.97 MANNING'S N = 0.010
DEPTH OF FLOW IN 18.0 INCH PIPE IS 13.3 INCHES
PIPE-FLOW VELOCITY(FEET/SEC.) = 5.39
GIVEN PIPE DIAMETER(INCH) = 18.00 NUMBER OF PIPES = 1
PIPE-FLOW(CFS) = 7.56
PIPE TRAVEL TIME(MIN.) = 0.87 Tc(MIN.) = 9.02
LONGEST FLOWPATH FROM NODE 9.00 TO NODE 27.10 = 1052.76 FEET.

FLOW PROCESS FROM NODE 27.10 TO NODE 27.10 IS CODE = 10

>>>>MAIN-STREAM MEMORY COPIED ONTO MEMORY BANK # 1 <<<<<

=====

FLOW PROCESS FROM NODE 27.10 TO NODE 27.10 IS CODE = 13

>>>>CLEAR THE MAIN-STREAM MEMORY<<<<<

=====

FLOW PROCESS FROM NODE 27.10 TO NODE 28.00 IS CODE = 41

>>>>COMPUTE PIPE-FLOW TRAVEL TIME THRU SUBAREA<<<<<

>>>>USING USER-SPECIFIED PIPESIZE (EXISTING ELEMENT)<<<<<

=====

REPRESENTATIVE SLOPE = 0.0040

FLOW LENGTH(FEET) = 71.25 MANNING'S N = 0.013

DEPTH OF FLOW IN 36.0 INCH PIPE IS 3.9 INCHES

PIPE-FLOW VELOCITY(FEET/SEC.) = 2.45

GIVEN PIPE DIAMETER(INCH) = 36.00 NUMBER OF PIPES = 1

PIPE-FLOW(CFS) = 1.00

PIPE TRAVEL TIME(MIN.) = 0.49 Tc(MIN.) = 5.49

LONGEST FLOWPATH FROM NODE 9.00 TO NODE 28.00 = 1124.01 FEET.

FLOW PROCESS FROM NODE 28.00 TO NODE 28.00 IS CODE = 10

>>>>MAIN-STREAM MEMORY COPIED ONTO MEMORY BANK # 1 <<<<<

=====

***MEMORY BANK # 1 IS FULL. THEREFORE, MAIN-STREAM MEMORY

DATA CAN NOT BE COPIED ONTO IT - PROCESS IGNORED.***

FLOW PROCESS FROM NODE 28.00 TO NODE 28.00 IS CODE = 13

>>>>CLEAR THE MAIN-STREAM MEMORY<<<<<

FLOW PROCESS FROM NODE 29.00 TO NODE 30.00 IS CODE = 21

>>>>RATIONAL METHOD INITIAL SUBAREA ANALYSIS<<<<<

=====

ASSUMED INITIAL SUBAREA UNIFORM

DEVELOPMENT IS APARTMENT

$TC = K * [(LENGTH^{**3}) / (ELEVATION CHANGE)]^{**0.2}$

INITIAL SUBAREA FLOW-LENGTH(FEET) = 61.88

UPSTREAM ELEVATION(FEET) = 882.80

DOWNSTREAM ELEVATION(FEET) = 882.10

ELEVATION DIFFERENCE(FEET) = 0.70

$TC = 0.323 * [(61.88^{**3}) / (0.70)]^{**0.2} = 4.118$

COMPUTED TIME OF CONCENTRATION INCREASED TO 5 MIN.

10 YEAR RAINFALL INTENSITY(INCH/HOUR) = 3.163

APARTMENT DEVELOPMENT RUNOFF COEFFICIENT = .8713

SOIL CLASSIFICATION IS "C"

SUBAREA RUNOFF(CFS) = 0.45

TOTAL AREA(ACRES) = 0.16 TOTAL RUNOFF(CFS) = 0.45

FLOW PROCESS FROM NODE 30.00 TO NODE 31.00 IS CODE = 41

>>>>COMPUTE PIPE-FLOW TRAVEL TIME THRU SUBAREA<<<<<
>>>>USING USER-SPECIFIED PIPESIZE (EXISTING ELEMENT)<<<<<

=====

REPRESENTATIVE SLOPE =	0.0100		
FLOW LENGTH(FEET) =	55.57	MANNING'S N =	0.009
ASSUME FULL-FLOWING PIPELINE			
PIPE-FLOW VELOCITY(FEET/SEC.) =	5.18		
PIPE FLOW VELOCITY = (TOTAL FLOW)/(PIPE CROSS SECTION AREA)			
GIVEN PIPE DIAMETER(INCH) =	4.00	NUMBER OF PIPES =	1
PIPE-FLOW(CFS) =	0.45		
PIPE TRAVEL TIME(MIN.) =	0.18	Tc(MIN.) =	5.18
LONGEST FLOWPATH FROM NODE	29.00 TO NODE	31.00 =	117.45 FEET.

FLOW PROCESS FROM NODE 31.00 TO NODE 32.00 IS CODE = 41

>>>>COMPUTE PIPE-FLOW TRAVEL TIME THRU SUBAREA<<<<<
>>>>USING USER-SPECIFIED PIPESIZE (EXISTING ELEMENT)<<<<<

=====

REPRESENTATIVE SLOPE =	0.0100		
FLOW LENGTH(FEET) =	89.09	MANNING'S N =	0.009
DEPTH OF FLOW IN 6.0 INCH PIPE IS	3.2 INCHES		
PIPE-FLOW VELOCITY(FEET/SEC.) =	4.16		
GIVEN PIPE DIAMETER(INCH) =	6.00	NUMBER OF PIPES =	1
PIPE-FLOW(CFS) =	0.45		
PIPE TRAVEL TIME(MIN.) =	0.36	Tc(MIN.) =	5.54
LONGEST FLOWPATH FROM NODE	29.00 TO NODE	32.00 =	206.54 FEET.

FLOW PROCESS FROM NODE 32.00 TO NODE 33.00 IS CODE = 41

>>>>COMPUTE PIPE-FLOW TRAVEL TIME THRU SUBAREA<<<<<
>>>>USING USER-SPECIFIED PIPESIZE (EXISTING ELEMENT)<<<<<

=====

REPRESENTATIVE SLOPE =	0.0100		
FLOW LENGTH(FEET) =	23.50	MANNING'S N =	0.009
DEPTH OF FLOW IN 8.0 INCH PIPE IS	2.8 INCHES		
PIPE-FLOW VELOCITY(FEET/SEC.) =	4.09		
GIVEN PIPE DIAMETER(INCH) =	8.00	NUMBER OF PIPES =	1
PIPE-FLOW(CFS) =	0.45		
PIPE TRAVEL TIME(MIN.) =	0.10	Tc(MIN.) =	5.63
LONGEST FLOWPATH FROM NODE	29.00 TO NODE	33.00 =	230.04 FEET.

FLOW PROCESS FROM NODE 33.00 TO NODE 33.00 IS CODE = 10

>>>>MAIN-STREAM MEMORY COPIED ONTO MEMORY BANK # 3 <<<<<

=====

FLOW PROCESS FROM NODE 33.00 TO NODE 33.00 IS CODE = 13

>>>>CLEAR THE MAIN-STREAM MEMORY<<<<<

=====

FLOW PROCESS FROM NODE 34.00 TO NODE 35.00 IS CODE = 21

>>>>RATIONAL METHOD INITIAL SUBAREA ANALYSIS<<<<<

=====

ASSUMED INITIAL SUBAREA UNIFORM
DEVELOPMENT IS APARTMENT

$TC = K * [(LENGTH^{**3}) / (ELEVATION CHANGE)]^{**.2}$

INITIAL SUBAREA FLOW-LENGTH(FEET) = 65.92

UPSTREAM ELEVATION(FEET) = 15.00

DOWNSTREAM ELEVATION(FEET) = 13.00

ELEVATION DIFFERENCE(FEET) = 2.00

$TC = 0.323 * [(65.92^{**3}) / (2.00)]^{**.2} = 3.467$

COMPUTED TIME OF CONCENTRATION INCREASED TO 5 MIN.

10 YEAR RAINFALL INTENSITY(INCH/HOUR) = 3.163

APARTMENT DEVELOPMENT RUNOFF COEFFICIENT = .8713

SOIL CLASSIFICATION IS "C"

SUBAREA RUNOFF(CFS) = 0.26

TOTAL AREA(ACRES) = 0.09 TOTAL RUNOFF(CFS) = 0.26

FLOW PROCESS FROM NODE 35.00 TO NODE 33.00 IS CODE = 41

>>>>COMPUTE PIPE-FLOW TRAVEL TIME THRU SUBAREA<<<<<

>>>>USING USER-SPECIFIED PIPESIZE (EXISTING ELEMENT)<<<<<

=====

REPRESENTATIVE SLOPE = 0.0100

FLOW LENGTH(FEET) = 2.00 MANNING'S N = 0.009

DEPTH OF FLOW IN 4.0 INCH PIPE IS 3.2 INCHES

PIPE-FLOW VELOCITY(FEET/SEC.) = 3.46

GIVEN PIPE DIAMETER(INCH) = 4.00 NUMBER OF PIPES = 1

PIPE-FLOW(CFS) = 0.26

PIPE TRAVEL TIME(MIN.) = 0.01 Tc(MIN.) = 5.01

LONGEST FLOWPATH FROM NODE 34.00 TO NODE 33.00 = 67.92 FEET.

FLOW PROCESS FROM NODE 33.00 TO NODE 33.00 IS CODE = 11

>>>>CONFLUENCE MEMORY BANK # 3 WITH THE MAIN-STREAM MEMORY<<<<<

=====

** MAIN STREAM CONFLUENCE DATA **

STREAM NUMBER	RUNOFF (CFS)	Tc (MIN.)	INTENSITY (INCH/HOUR)	AREA (ACRE)
1	0.26	5.01	3.159	0.09

LONGEST FLOWPATH FROM NODE 34.00 TO NODE 33.00 = 67.92 FEET.

** MEMORY BANK # 3 CONFLUENCE DATA **

STREAM NUMBER	RUNOFF (CFS)	Tc (MIN.)	INTENSITY (INCH/HOUR)	AREA (ACRE)
1	0.45	5.63	2.963	0.16

LONGEST FLOWPATH FROM NODE 29.00 TO NODE 33.00 = 230.04 FEET.

** PEAK FLOW RATE TABLE **

STREAM NUMBER	RUNOFF (CFS)	Tc (MIN.)	INTENSITY (INCH/HOUR)
1	0.66	5.01	3.159
2	0.69	5.63	2.963

COMPUTED CONFLUENCE ESTIMATES ARE AS FOLLOWS:

PEAK FLOW RATE(CFS) = 0.69 Tc(MIN.) = 5.63
TOTAL AREA(ACRES) = 0.3

FLOW PROCESS FROM NODE 33.00 TO NODE 33.00 IS CODE = 12

>>>>CLEAR MEMORY BANK # 3 <<<<<

FLOW PROCESS FROM NODE 33.00 TO NODE 36.00 IS CODE = 41

>>>>COMPUTE PIPE-FLOW TRAVEL TIME THRU SUBAREA<<<<<
>>>>USING USER-SPECIFIED PIPESIZE (EXISTING ELEMENT)<<<<<

=====

REPRESENTATIVE SLOPE = 0.0100
FLOW LENGTH(FEET) = 48.57 MANNING'S N = 0.009
DEPTH OF FLOW IN 8.0 INCH PIPE IS 3.6 INCHES
PIPE-FLOW VELOCITY(FEET/SEC.) = 4.62
GIVEN PIPE DIAMETER(INCH) = 8.00 NUMBER OF PIPES = 1
PIPE-FLOW(CFS) = 0.69
PIPE TRAVEL TIME(MIN.) = 0.18 Tc(MIN.) = 5.81
LONGEST FLOWPATH FROM NODE 29.00 TO NODE 36.00 = 278.61 FEET.

FLOW PROCESS FROM NODE 36.00 TO NODE 36.00 IS CODE = 10

>>>>MAIN-STREAM MEMORY COPIED ONTO MEMORY BANK # 3 <<<<<

FLOW PROCESS FROM NODE 34.00 TO NODE 34.00 IS CODE = 13

>>>>CLEAR THE MAIN-STREAM MEMORY<<<<<

FLOW PROCESS FROM NODE 37.00 TO NODE 38.00 IS CODE = 21

>>>>RATIONAL METHOD INITIAL SUBAREA ANALYSIS<<<<<

ASSUMED INITIAL SUBAREA UNIFORM
DEVELOPMENT IS: UNDEVELOPED WITH GOOD COVER
TC = $K * [(LENGTH^{**3}) / (ELEVATION CHANGE)]^{**0.2}$
INITIAL SUBAREA FLOW-LENGTH(FEET) = 47.00
UPSTREAM ELEVATION(FEET) = 879.59
DOWNSTREAM ELEVATION(FEET) = 878.75
ELEVATION DIFFERENCE(FEET) = 0.84
TC = $0.937 * [(47.00^{**3}) / (0.84)]^{**0.2} = 9.780$
10 YEAR RAINFALL INTENSITY(INCH/HOUR) = 2.188
UNDEVELOPED WATERSHED RUNOFF COEFFICIENT = .7066
SOIL CLASSIFICATION IS "C"
SUBAREA RUNOFF(CFS) = 0.14
TOTAL AREA(ACRES) = 0.09 TOTAL RUNOFF(CFS) = 0.14

FLOW PROCESS FROM NODE 38.00 TO NODE 36.00 IS CODE = 41

>>>>COMPUTE PIPE-FLOW TRAVEL TIME THRU SUBAREA<<<<<
>>>>USING USER-SPECIFIED PIPESIZE (EXISTING ELEMENT)<<<<<

REPRESENTATIVE SLOPE = 0.0100
FLOW LENGTH(FEET) = 14.50 MANNING'S N = 0.009
DEPTH OF FLOW IN 10.0 INCH PIPE IS 1.4 INCHES
PIPE-FLOW VELOCITY(FEET/SEC.) = 2.88
GIVEN PIPE DIAMETER(INCH) = 10.00 NUMBER OF PIPES = 1
PIPE-FLOW(CFS) = 0.14
PIPE TRAVEL TIME(MIN.) = 0.08 Tc(MIN.) = 9.86
LONGEST FLOWPATH FROM NODE 37.00 TO NODE 36.00 = 61.50 FEET.

FLOW PROCESS FROM NODE 36.00 TO NODE 36.00 IS CODE = 11

>>>>CONFLUENCE MEMORY BANK # 3 WITH THE MAIN-STREAM MEMORY<<<<<

** MAIN STREAM CONFLUENCE DATA **

STREAM NUMBER	RUNOFF (CFS)	Tc (MIN.)	INTENSITY (INCH/HOUR)	AREA (ACRE)
1	0.14	9.86	2.178	0.09

LONGEST FLOWPATH FROM NODE 37.00 TO NODE 36.00 = 61.50 FEET.

** MEMORY BANK # 3 CONFLUENCE DATA **

STREAM NUMBER	RUNOFF (CFS)	Tc (MIN.)	INTENSITY (INCH/HOUR)	AREA (ACRE)	
1	0.66	5.19	3.100	0.26	
2	0.69	5.81	2.913	0.26	
LONGEST FLOWPATH FROM NODE			29.00 TO NODE	36.00 =	278.61 FEET.

** PEAK FLOW RATE TABLE **

STREAM NUMBER	RUNOFF (CFS)	Tc (MIN.)	INTENSITY (INCH/HOUR)
1	0.73	5.19	3.100
2	0.77	5.81	2.913
3	0.66	9.86	2.178

COMPUTED CONFLUENCE ESTIMATES ARE AS FOLLOWS:

PEAK FLOW RATE(CFS) = 0.77 Tc(MIN.) = 5.81
TOTAL AREA(ACRES) = 0.3

FLOW PROCESS FROM NODE 36.00 TO NODE 39.00 IS CODE = 41

>>>>COMPUTE PIPE-FLOW TRAVEL TIME THRU SUBAREA<<<<<
>>>>USING USER-SPECIFIED PIPESIZE (EXISTING ELEMENT)<<<<<

=====

REPRESENTATIVE SLOPE = 0.0100
FLOW LENGTH(FEET) = 52.84 MANNING'S N = 0.009
DEPTH OF FLOW IN 10.0 INCH PIPE IS 3.4 INCHES
PIPE-FLOW VELOCITY(FEET/SEC.) = 4.72
GIVEN PIPE DIAMETER(INCH) = 10.00 NUMBER OF PIPES = 1
PIPE-FLOW(CFS) = 0.77
PIPE TRAVEL TIME(MIN.) = 0.19 Tc(MIN.) = 5.99
LONGEST FLOWPATH FROM NODE 29.00 TO NODE 39.00 = 331.45 FEET.

FLOW PROCESS FROM NODE 39.00 TO NODE 39.00 IS CODE = 10

>>>>MAIN-STREAM MEMORY COPIED ONTO MEMORY BANK # 3 <<<<<

=====

***MEMORY BANK # 3 IS FULL. THEREFORE, MAIN-STREAM MEMORY
DATA CAN NOT BE COPIED ONTO IT - PROCESS IGNORED.***

FLOW PROCESS FROM NODE 39.00 TO NODE 39.00 IS CODE = 13

>>>>CLEAR THE MAIN-STREAM MEMORY<<<<<

FLOW PROCESS FROM NODE 40.00 TO NODE 41.00 IS CODE = 21

>>>>RATIONAL METHOD INITIAL SUBAREA ANALYSIS<<<<<

=====

ASSUMED INITIAL SUBAREA UNIFORM
DEVELOPMENT IS APARTMENT

TC = $K * [(LENGTH^{**3}) / (ELEVATION CHANGE)]^{**0.2}$
INITIAL SUBAREA FLOW-LENGTH(FEET) = 74.92
UPSTREAM ELEVATION(FEET) = 15.00
DOWNSTREAM ELEVATION(FEET) = 13.00
ELEVATION DIFFERENCE(FEET) = 2.00
TC = $0.323 * [(74.92^{**3}) / (2.00)]^{**0.2} = 3.744$
COMPUTED TIME OF CONCENTRATION INCREASED TO 5 MIN.
10 YEAR RAINFALL INTENSITY(INCH/HOUR) = 3.163
APARTMENT DEVELOPMENT RUNOFF COEFFICIENT = .8713
SOIL CLASSIFICATION IS "C"
SUBAREA RUNOFF(CFS) = 1.11
TOTAL AREA(ACRES) = 0.40 TOTAL RUNOFF(CFS) = 1.11

FLOW PROCESS FROM NODE 41.00 TO NODE 39.00 IS CODE = 41

>>>>COMPUTE PIPE-FLOW TRAVEL TIME THRU SUBAREA<<<<<
>>>>USING USER-SPECIFIED PIPESIZE (EXISTING ELEMENT)<<<<<

=====

REPRESENTATIVE SLOPE = 0.0100
FLOW LENGTH(FEET) = 7.00 MANNING'S N = 0.009
ASSUME FULL-FLOWING PIPELINE
PIPE-FLOW VELOCITY(FEET/SEC.) = 12.76
PIPE FLOW VELOCITY = (TOTAL FLOW)/(PIPE CROSS SECTION AREA)
GIVEN PIPE DIAMETER(INCH) = 4.00 NUMBER OF PIPES = 1
PIPE-FLOW(CFS) = 1.11
PIPE TRAVEL TIME(MIN.) = 0.01 Tc(MIN.) = 5.01
LONGEST FLOWPATH FROM NODE 40.00 TO NODE 39.00 = 81.92 FEET.

FLOW PROCESS FROM NODE 39.00 TO NODE 39.00 IS CODE = 11

>>>>CONFLUENCE MEMORY BANK # 3 WITH THE MAIN-STREAM MEMORY<<<<<

=====

** MAIN STREAM CONFLUENCE DATA **

STREAM NUMBER	RUNOFF (CFS)	Tc (MIN.)	INTENSITY (INCH/HOUR)	AREA (ACRE)
1	1.11	5.01	3.159	0.40

LONGEST FLOWPATH FROM NODE 40.00 TO NODE 39.00 = 81.92 FEET.

** MEMORY BANK # 3 CONFLUENCE DATA **

STREAM NUMBER	RUNOFF (CFS)	Tc (MIN.)	INTENSITY (INCH/HOUR)	AREA (ACRE)
1	0.66	5.19	3.100	0.26

2 0.69 5.81 2.913 0.26
LONGEST FLOWPATH FROM NODE 29.00 TO NODE 39.00 = 278.61 FEET.

** PEAK FLOW RATE TABLE **

STREAM NUMBER	RUNOFF (CFS)	Tc (MIN.)	INTENSITY (INCH/HOUR)
1	1.75	5.01	3.159
2	1.75	5.19	3.100
3	1.72	5.81	2.913

COMPUTED CONFLUENCE ESTIMATES ARE AS FOLLOWS:

PEAK FLOW RATE(CFS) = 1.75 Tc(MIN.) = 5.19
TOTAL AREA(ACRES) = 0.7

FLOW PROCESS FROM NODE 39.00 TO NODE 39.00 IS CODE = 12

>>>>CLEAR MEMORY BANK # 3 <<<<<

FLOW PROCESS FROM NODE 39.00 TO NODE 42.00 IS CODE = 41

>>>>COMPUTE PIPE-FLOW TRAVEL TIME THRU SUBAREA<<<<<
>>>>USING USER-SPECIFIED PIPESIZE (EXISTING ELEMENT)<<<<<

=====

REPRESENTATIVE SLOPE = 0.0100
FLOW LENGTH(FEET) = 52.87 MANNING'S N = 0.009
DEPTH OF FLOW IN 10.0 INCH PIPE IS 5.4 INCHES
PIPE-FLOW VELOCITY(FEET/SEC.) = 5.83
GIVEN PIPE DIAMETER(INCH) = 10.00 NUMBER OF PIPES = 1
PIPE-FLOW(CFS) = 1.75
PIPE TRAVEL TIME(MIN.) = 0.15 Tc(MIN.) = 5.34
LONGEST FLOWPATH FROM NODE 29.00 TO NODE 42.00 = 331.48 FEET.

FLOW PROCESS FROM NODE 42.00 TO NODE 43.00 IS CODE = 41

>>>>COMPUTE PIPE-FLOW TRAVEL TIME THRU SUBAREA<<<<<
>>>>USING USER-SPECIFIED PIPESIZE (EXISTING ELEMENT)<<<<<

=====

REPRESENTATIVE SLOPE = 0.0100
FLOW LENGTH(FEET) = 91.61 MANNING'S N = 0.010
DEPTH OF FLOW IN 12.0 INCH PIPE IS 5.2 INCHES
PIPE-FLOW VELOCITY(FEET/SEC.) = 5.38
GIVEN PIPE DIAMETER(INCH) = 12.00 NUMBER OF PIPES = 1
PIPE-FLOW(CFS) = 1.75
PIPE TRAVEL TIME(MIN.) = 0.28 Tc(MIN.) = 5.62
LONGEST FLOWPATH FROM NODE 29.00 TO NODE 43.00 = 423.09 FEET.

FLOW PROCESS FROM NODE 43.00 TO NODE 43.00 IS CODE = 10

>>>>MAIN-STREAM MEMORY COPIED ONTO MEMORY BANK # 3 <<<<<
=====

FLOW PROCESS FROM NODE 43.00 TO NODE 43.00 IS CODE = 13

>>>>CLEAR THE MAIN-STREAM MEMORY<<<<<
=====

FLOW PROCESS FROM NODE 44.00 TO NODE 45.00 IS CODE = 21

>>>>RATIONAL METHOD INITIAL SUBAREA ANALYSIS<<<<<
=====

ASSUMED INITIAL SUBAREA UNIFORM
DEVELOPMENT IS APARTMENT
TC = $K * [(LENGTH^{**3}) / (ELEVATION CHANGE)]^{**0.2}$
INITIAL SUBAREA FLOW-LENGTH(FEET) = 47.00
UPSTREAM ELEVATION(FEET) = 15.00
DOWNSTREAM ELEVATION(FEET) = 13.00
ELEVATION DIFFERENCE(FEET) = 2.00
TC = $0.323 * [(47.00^{**3}) / (2.00)]^{**0.2} = 2.830$
COMPUTED TIME OF CONCENTRATION INCREASED TO 5 MIN.
10 YEAR RAINFALL INTENSITY(INCH/HOUR) = 3.163
APARTMENT DEVELOPMENT RUNOFF COEFFICIENT = .8713
SOIL CLASSIFICATION IS "C"
SUBAREA RUNOFF(CFS) = 0.97
TOTAL AREA(ACRES) = 0.35 TOTAL RUNOFF(CFS) = 0.97

FLOW PROCESS FROM NODE 45.00 TO NODE 46.00 IS CODE = 41

>>>>COMPUTE PIPE-FLOW TRAVEL TIME THRU SUBAREA<<<<<
>>>>USING USER-SPECIFIED PIPESIZE (EXISTING ELEMENT)<<<<<
=====

REPRESENTATIVE SLOPE = 0.0100
FLOW LENGTH(FEET) = 32.65 MANNING'S N = 0.009
ASSUME FULL-FLOWING PIPELINE
PIPE-FLOW VELOCITY(FEET/SEC.) = 4.95
PIPE FLOW VELOCITY = (TOTAL FLOW)/(PIPE CROSS SECTION AREA)
GIVEN PIPE DIAMETER(INCH) = 6.00 NUMBER OF PIPES = 1
PIPE-FLOW(CFS) = 0.97
PIPE TRAVEL TIME(MIN.) = 0.11 Tc(MIN.) = 5.11
LONGEST FLOWPATH FROM NODE 44.00 TO NODE 46.00 = 79.65 FEET.

FLOW PROCESS FROM NODE 46.00 TO NODE 47.00 IS CODE = 41

>>>>COMPUTE PIPE-FLOW TRAVEL TIME THRU SUBAREA<<<<<
>>>>USING USER-SPECIFIED PIPESIZE (EXISTING ELEMENT)<<<<<

=====

REPRESENTATIVE SLOPE =	0.0100		
FLOW LENGTH(FEET) =	231.00	MANNING'S N =	0.009
DEPTH OF FLOW IN	8.0 INCH PIPE IS	4.3 INCHES	
PIPE-FLOW VELOCITY(FEET/SEC.) =	5.04		
GIVEN PIPE DIAMETER(INCH) =	8.00	NUMBER OF PIPES =	1
PIPE-FLOW(CFS) =	0.97		
PIPE TRAVEL TIME(MIN.) =	0.76	Tc(MIN.) =	5.87
LONGEST FLOWPATH FROM NODE	44.00 TO NODE	47.00 =	310.65 FEET.

FLOW PROCESS FROM NODE 47.00 TO NODE 47.00 IS CODE = 81

>>>>ADDITION OF SUBAREA TO MAINLINE PEAK FLOW<<<<<

=====

10 YEAR RAINFALL INTENSITY(INCH/HOUR) =	2.895		
APARTMENT DEVELOPMENT RUNOFF COEFFICIENT =	.8691		
SOIL CLASSIFICATION IS	"C"		
SUBAREA AREA(ACRES) =	0.22	SUBAREA RUNOFF(CFS) =	0.56
TOTAL AREA(ACRES) =	0.6	TOTAL RUNOFF(CFS) =	1.53
TC(MIN.) =	5.87		

FLOW PROCESS FROM NODE 47.00 TO NODE 48.00 IS CODE = 41

>>>>COMPUTE PIPE-FLOW TRAVEL TIME THRU SUBAREA<<<<<
>>>>USING USER-SPECIFIED PIPESIZE (EXISTING ELEMENT)<<<<<

=====

REPRESENTATIVE SLOPE =	0.0100		
FLOW LENGTH(FEET) =	40.21	MANNING'S N =	0.009
DEPTH OF FLOW IN	8.0 INCH PIPE IS	5.9 INCHES	
PIPE-FLOW VELOCITY(FEET/SEC.) =	5.51		
GIVEN PIPE DIAMETER(INCH) =	8.00	NUMBER OF PIPES =	1
PIPE-FLOW(CFS) =	1.53		
PIPE TRAVEL TIME(MIN.) =	0.12	Tc(MIN.) =	6.00
LONGEST FLOWPATH FROM NODE	44.00 TO NODE	48.00 =	350.86 FEET.

FLOW PROCESS FROM NODE 48.00 TO NODE 48.00 IS CODE = 81

>>>>ADDITION OF SUBAREA TO MAINLINE PEAK FLOW<<<<<

=====

10 YEAR RAINFALL INTENSITY(INCH/HOUR) =	2.863		
APARTMENT DEVELOPMENT RUNOFF COEFFICIENT =	.8689		
SOIL CLASSIFICATION IS	"C"		
SUBAREA AREA(ACRES) =	0.29	SUBAREA RUNOFF(CFS) =	0.72
TOTAL AREA(ACRES) =	0.9	TOTAL RUNOFF(CFS) =	2.25

TC(MIN.) = 6.00

FLOW PROCESS FROM NODE 48.00 TO NODE 43.00 IS CODE = 41

>>>>COMPUTE PIPE-FLOW TRAVEL TIME THRU SUBAREA<<<<<
>>>>USING USER-SPECIFIED PIPESIZE (EXISTING ELEMENT)<<<<<

=====

REPRESENTATIVE SLOPE = 0.0100
FLOW LENGTH(FEET) = 98.04 MANNING'S N = 0.009
ASSUME FULL-FLOWING PIPELINE
PIPE-FLOW VELOCITY(FEET/SEC.) = 6.45
PIPE FLOW VELOCITY = (TOTAL FLOW)/(PIPE CROSS SECTION AREA)
GIVEN PIPE DIAMETER(INCH) = 8.00 NUMBER OF PIPES = 1
PIPE-FLOW(CFS) = 2.25
PIPE TRAVEL TIME(MIN.) = 0.25 Tc(MIN.) = 6.25
LONGEST FLOWPATH FROM NODE 44.00 TO NODE 43.00 = 448.90 FEET.

FLOW PROCESS FROM NODE 43.00 TO NODE 43.00 IS CODE = 11

>>>>CONFLUENCE MEMORY BANK # 3 WITH THE MAIN-STREAM MEMORY<<<<<

=====

** MAIN STREAM CONFLUENCE DATA **

STREAM NUMBER	RUNOFF (CFS)	Tc (MIN.)	INTENSITY (INCH/HOUR)	AREA (ACRE)
1	2.25	6.25	2.798	0.86

LONGEST FLOWPATH FROM NODE 44.00 TO NODE 43.00 = 448.90 FEET.

** MEMORY BANK # 3 CONFLUENCE DATA **

STREAM NUMBER	RUNOFF (CFS)	Tc (MIN.)	INTENSITY (INCH/HOUR)	AREA (ACRE)
1	1.75	5.44	3.018	0.66
2	1.75	5.62	2.966	0.66
3	1.72	6.24	2.800	0.66

LONGEST FLOWPATH FROM NODE 29.00 TO NODE 43.00 = 423.09 FEET.

** PEAK FLOW RATE TABLE **

STREAM NUMBER	RUNOFF (CFS)	Tc (MIN.)	INTENSITY (INCH/HOUR)
1	3.71	5.44	3.018
2	3.77	5.62	2.966
3	3.97	6.24	2.800
4	3.97	6.25	2.798

COMPUTED CONFLUENCE ESTIMATES ARE AS FOLLOWS:

PEAK FLOW RATE(CFS) = 3.97 Tc(MIN.) = 6.25
TOTAL AREA(ACRES) = 1.5

FLOW PROCESS FROM NODE 43.00 TO NODE 43.00 IS CODE = 12

>>>>CLEAR MEMORY BANK # 3 <<<<<

FLOW PROCESS FROM NODE 43.00 TO NODE 49.00 IS CODE = 41

>>>>COMPUTE PIPE-FLOW TRAVEL TIME THRU SUBAREA<<<<<
>>>>USING USER-SPECIFIED PIPESIZE (EXISTING ELEMENT)<<<<<

REPRESENTATIVE SLOPE = 0.0100
FLOW LENGTH(FEET) = 33.92 MANNING'S N = 0.010
DEPTH OF FLOW IN 12.0 INCH PIPE IS 8.7 INCHES
PIPE-FLOW VELOCITY(FEET/SEC.) = 6.48
GIVEN PIPE DIAMETER(INCH) = 12.00 NUMBER OF PIPES = 1
PIPE-FLOW(CFS) = 3.97
PIPE TRAVEL TIME(MIN.) = 0.09 Tc(MIN.) = 6.34
LONGEST FLOWPATH FROM NODE 44.00 TO NODE 49.00 = 482.82 FEET.

FLOW PROCESS FROM NODE 49.00 TO NODE 49.00 IS CODE = 10

>>>>MAIN-STREAM MEMORY COPIED ONTO MEMORY BANK # 2 <<<<<

FLOW PROCESS FROM NODE 49.00 TO NODE 49.00 IS CODE = 13

>>>>CLEAR THE MAIN-STREAM MEMORY<<<<<

FLOW PROCESS FROM NODE 50.00 TO NODE 51.00 IS CODE = 21

>>>>RATIONAL METHOD INITIAL SUBAREA ANALYSIS<<<<<

ASSUMED INITIAL SUBAREA UNIFORM
DEVELOPMENT IS APARTMENT
TC = K*[(LENGTH**3)/(ELEVATION CHANGE)]**.2
INITIAL SUBAREA FLOW-LENGTH(FEET) = 97.11
UPSTREAM ELEVATION(FEET) = 878.85
DOWNSTREAM ELEVATION(FEET) = 877.75
ELEVATION DIFFERENCE(FEET) = 1.10
TC = 0.323*[(97.11**3)/(1.10)]**.2 = 4.930
COMPUTED TIME OF CONCENTRATION INCREASED TO 5 MIN.
10 YEAR RAINFALL INTENSITY(INCH/HOUR) = 3.163
APARTMENT DEVELOPMENT RUNOFF COEFFICIENT = .8713
SOIL CLASSIFICATION IS "C"

SUBAREA RUNOFF(CFS) = 0.93
TOTAL AREA(ACRES) = 0.34 TOTAL RUNOFF(CFS) = 0.93

FLOW PROCESS FROM NODE 51.00 TO NODE 51.00 IS CODE = 11

>>>>>CONFLUENCE MEMORY BANK # 2 WITH THE MAIN-STREAM MEMORY<<<<<<

** MAIN STREAM CONFLUENCE DATA **

STREAM NUMBER	RUNOFF (CFS)	Tc (MIN.)	INTENSITY (INCH/HOUR)	AREA (ACRE)
1	0.93	5.00	3.163	0.34

LONGEST FLOWPATH FROM NODE 50.00 TO NODE 51.00 = 97.11 FEET.

** MEMORY BANK # 2 CONFLUENCE DATA **

STREAM NUMBER	RUNOFF (CFS)	Tc (MIN.)	INTENSITY (INCH/HOUR)	AREA (ACRE)
1	3.71	5.53	2.992	1.52
2	3.77	5.71	2.940	1.52
3	3.97	6.33	2.778	1.52
4	3.97	6.34	2.777	1.52

LONGEST FLOWPATH FROM NODE 44.00 TO NODE 51.00 = 482.82 FEET.

** PEAK FLOW RATE TABLE **

STREAM NUMBER	RUNOFF (CFS)	Tc (MIN.)	INTENSITY (INCH/HOUR)
1	4.28	5.00	3.163
2	4.59	5.53	2.992
3	4.64	5.71	2.940
4	4.78	6.33	2.778
5	4.78	6.34	2.777

COMPUTED CONFLUENCE ESTIMATES ARE AS FOLLOWS:

PEAK FLOW RATE(CFS) = 4.78 Tc(MIN.) = 6.34
TOTAL AREA(ACRES) = 1.9

FLOW PROCESS FROM NODE 51.00 TO NODE 51.00 IS CODE = 12

>>>>>CLEAR MEMORY BANK # 2 <<<<<<

FLOW PROCESS FROM NODE 51.00 TO NODE 52.00 IS CODE = 41

>>>>>COMPUTE PIPE-FLOW TRAVEL TIME THRU SUBAREA<<<<<<
>>>>>USING USER-SPECIFIED PIPESIZE (EXISTING ELEMENT)<<<<<<

REPRESENTATIVE SLOPE = 0.0100

FLOW LENGTH(FEET) = 51.05 MANNING'S N = 0.010
DEPTH OF FLOW IN 15.0 INCH PIPE IS 8.2 INCHES
PIPE-FLOW VELOCITY(FEET/SEC.) = 6.93
GIVEN PIPE DIAMETER(INCH) = 15.00 NUMBER OF PIPES = 1
PIPE-FLOW(CFS) = 4.78
PIPE TRAVEL TIME(MIN.) = 0.12 Tc(MIN.) = 6.46
LONGEST FLOWPATH FROM NODE 44.00 TO NODE 52.00 = 533.87 FEET.

FLOW PROCESS FROM NODE 52.00 TO NODE 52.00 IS CODE = 10

>>>>MAIN-STREAM MEMORY COPIED ONTO MEMORY BANK # 2 <<<<<
=====

FLOW PROCESS FROM NODE 52.00 TO NODE 52.00 IS CODE = 13

>>>>CLEAR THE MAIN-STREAM MEMORY<<<<<
=====

FLOW PROCESS FROM NODE 53.00 TO NODE 54.00 IS CODE = 21

>>>>RATIONAL METHOD INITIAL SUBAREA ANALYSIS<<<<<
=====

ASSUMED INITIAL SUBAREA UNIFORM
DEVELOPMENT IS APARTMENT
 $TC = K * [(LENGTH^{**3}) / (ELEVATION CHANGE)]^{** .2}$
INITIAL SUBAREA FLOW-LENGTH(FEET) = 96.84
UPSTREAM ELEVATION(FEET) = 878.85
DOWNSTREAM ELEVATION(FEET) = 877.60
ELEVATION DIFFERENCE(FEET) = 1.25
 $TC = 0.323 * [(96.84^{**3}) / (1.25)]^{** .2} = 4.798$
COMPUTED TIME OF CONCENTRATION INCREASED TO 5 MIN.
10 YEAR RAINFALL INTENSITY(INCH/HOUR) = 3.163
APARTMENT DEVELOPMENT RUNOFF COEFFICIENT = .8713
SOIL CLASSIFICATION IS "C"
SUBAREA RUNOFF(CFS) = 0.85
TOTAL AREA(ACRES) = 0.31 TOTAL RUNOFF(CFS) = 0.85

FLOW PROCESS FROM NODE 54.00 TO NODE 54.00 IS CODE = 10

>>>>MAIN-STREAM MEMORY COPIED ONTO MEMORY BANK # 3 <<<<<
=====

FLOW PROCESS FROM NODE 54.00 TO NODE 54.00 IS CODE = 13

>>>>CLEAR THE MAIN-STREAM MEMORY<<<<<

FLOW PROCESS FROM NODE 55.00 TO NODE 56.00 IS CODE = 21

>>>>RATIONAL METHOD INITIAL SUBAREA ANALYSIS<<<<<

=====

ASSUMED INITIAL SUBAREA UNIFORM
DEVELOPMENT IS APARTMENT

TC = $K * [(LENGTH^{**3}) / (ELEVATION CHANGE)]^{**0.2}$
INITIAL SUBAREA FLOW-LENGTH(FEET) = 217.19
UPSTREAM ELEVATION(FEET) = 881.21
DOWNSTREAM ELEVATION(FEET) = 878.03
ELEVATION DIFFERENCE(FEET) = 3.18
TC = $0.323 * [(217.19^{**3}) / (3.18)]^{**0.2} = 6.463$
10 YEAR RAINFALL INTENSITY(INCH/HOUR) = 2.747
APARTMENT DEVELOPMENT RUNOFF COEFFICIENT = .8678
SOIL CLASSIFICATION IS "C"
SUBAREA RUNOFF(CFS) = 2.66
TOTAL AREA(ACRES) = 1.12 TOTAL RUNOFF(CFS) = 2.66

FLOW PROCESS FROM NODE 56.00 TO NODE 57.00 IS CODE = 41

>>>>COMPUTE PIPE-FLOW TRAVEL TIME THRU SUBAREA<<<<<
>>>>USING USER-SPECIFIED PIPESIZE (EXISTING ELEMENT)<<<<<

=====

REPRESENTATIVE SLOPE = 0.0100
FLOW LENGTH(FEET) = 140.51 MANNING'S N = 0.009
ASSUME FULL-FLOWING PIPELINE
PIPE-FLOW VELOCITY(FEET/SEC.) = 7.63
PIPE FLOW VELOCITY = (TOTAL FLOW)/(PIPE CROSS SECTION AREA)
GIVEN PIPE DIAMETER(INCH) = 8.00 NUMBER OF PIPES = 1
PIPE-FLOW(CFS) = 2.66
PIPE TRAVEL TIME(MIN.) = 0.31 Tc(MIN.) = 6.77
LONGEST FLOWPATH FROM NODE 55.00 TO NODE 57.00 = 357.70 FEET.

FLOW PROCESS FROM NODE 57.00 TO NODE 57.00 IS CODE = 11

>>>>CONFLUENCE MEMORY BANK # 3 WITH THE MAIN-STREAM MEMORY<<<<<

=====

** MAIN STREAM CONFLUENCE DATA **

STREAM NUMBER	RUNOFF (CFS)	Tc (MIN.)	INTENSITY (INCH/HOUR)	AREA (ACRE)
1	2.66	6.77	2.678	1.12

LONGEST FLOWPATH FROM NODE 55.00 TO NODE 57.00 = 357.70 FEET.

** MEMORY BANK # 3 CONFLUENCE DATA **

STREAM NUMBER	RUNOFF (CFS)	Tc (MIN.)	INTENSITY (INCH/HOUR)	AREA (ACRE)
1	0.85	5.00	3.163	0.31

LONGEST FLOWPATH FROM NODE 53.00 TO NODE 57.00 = 96.84 FEET.

** PEAK FLOW RATE TABLE **

STREAM NUMBER	RUNOFF (CFS)	Tc (MIN.)	INTENSITY (INCH/HOUR)
1	2.82	5.00	3.163
2	3.39	6.77	2.678

COMPUTED CONFLUENCE ESTIMATES ARE AS FOLLOWS:

PEAK FLOW RATE(CFS) = 3.39 Tc(MIN.) = 6.77
TOTAL AREA(ACRES) = 1.4

FLOW PROCESS FROM NODE 57.00 TO NODE 57.00 IS CODE = 11

>>>>CONFLUENCE MEMORY BANK # 2 WITH THE MAIN-STREAM MEMORY<<<<<

** MAIN STREAM CONFLUENCE DATA **

STREAM NUMBER	RUNOFF (CFS)	Tc (MIN.)	INTENSITY (INCH/HOUR)	AREA (ACRE)
1	2.82	5.00	3.163	1.43
2	3.39	6.77	2.678	1.43

LONGEST FLOWPATH FROM NODE 55.00 TO NODE 57.00 = 357.70 FEET.

** MEMORY BANK # 2 CONFLUENCE DATA **

STREAM NUMBER	RUNOFF (CFS)	Tc (MIN.)	INTENSITY (INCH/HOUR)	AREA (ACRE)
1	4.28	5.13	3.120	1.86
2	4.59	5.66	2.956	1.86
3	4.64	5.83	2.906	1.86
4	4.78	6.45	2.749	1.86
5	4.78	6.46	2.748	1.86

LONGEST FLOWPATH FROM NODE 44.00 TO NODE 57.00 = 533.87 FEET.

** PEAK FLOW RATE TABLE **

STREAM NUMBER	RUNOFF (CFS)	Tc (MIN.)	INTENSITY (INCH/HOUR)
1	7.00	5.00	3.163
2	7.06	5.13	3.120
3	7.42	5.66	2.956
4	7.56	5.83	2.906
5	8.01	6.45	2.749
6	8.01	6.46	2.748
7	8.05	6.77	2.678

COMPUTED CONFLUENCE ESTIMATES ARE AS FOLLOWS:

PEAK FLOW RATE(CFS) = 8.05 Tc(MIN.) = 6.77
TOTAL AREA(ACRES) = 3.3

FLOW PROCESS FROM NODE 57.00 TO NODE 57.00 IS CODE = 12

>>>>CLEAR MEMORY BANK # 2 <<<<<

FLOW PROCESS FROM NODE 57.00 TO NODE 57.00 IS CODE = 12

>>>>CLEAR MEMORY BANK # 3 <<<<<

FLOW PROCESS FROM NODE 57.00 TO NODE 58.00 IS CODE = 41

>>>>COMPUTE PIPE-FLOW TRAVEL TIME THRU SUBAREA<<<<<
>>>>USING USER-SPECIFIED PIPESIZE (EXISTING ELEMENT)<<<<<

REPRESENTATIVE SLOPE = 0.0100
FLOW LENGTH(FEET) = 77.27 MANNING'S N = 0.010
DEPTH OF FLOW IN 18.0 INCH PIPE IS 10.1 INCHES
PIPE-FLOW VELOCITY(FEET/SEC.) = 7.89
GIVEN PIPE DIAMETER(INCH) = 18.00 NUMBER OF PIPES = 1
PIPE-FLOW(CFS) = 8.05
PIPE TRAVEL TIME(MIN.) = 0.16 Tc(MIN.) = 6.93
LONGEST FLOWPATH FROM NODE 44.00 TO NODE 58.00 = 611.14 FEET.

FLOW PROCESS FROM NODE 58.00 TO NODE 58.00 IS CODE = 11

>>>>CONFLUENCE MEMORY BANK # 1 WITH THE MAIN-STREAM MEMORY<<<<<

** MAIN STREAM CONFLUENCE DATA **

STREAM NUMBER	RUNOFF (CFS)	Tc (MIN.)	INTENSITY (INCH/HOUR)	AREA (ACRE)
1	7.00	5.17	3.105	3.29
2	7.06	5.29	3.065	3.29
3	7.42	5.82	2.909	3.29
4	7.56	6.00	2.862	3.29
5	8.01	6.62	2.712	3.29
6	8.01	6.62	2.710	3.29
7	8.05	6.93	2.643	3.29

LONGEST FLOWPATH FROM NODE 44.00 TO NODE 58.00 = 611.14 FEET.

** MEMORY BANK # 1 CONFLUENCE DATA **

STREAM	RUNOFF	Tc	INTENSITY	AREA
--------	--------	----	-----------	------

NUMBER	(CFS)	(MIN.)	(INCH/HOUR)	(ACRE)
1	6.73	6.94	2.642	3.38
2	7.12	7.24	2.580	3.38
3	7.31	7.45	2.540	3.38
4	7.33	7.47	2.537	3.38
5	7.42	7.62	2.509	3.38
6	7.47	7.68	2.498	3.38
7	7.53	7.99	2.445	3.38
8	7.56	9.00	2.290	3.38
9	7.56	9.02	2.288	3.38
10	5.31	16.19	1.659	3.38

LONGEST FLOWPATH FROM NODE 9.00 TO NODE 58.00 = 1052.76 FEET.

** PEAK FLOW RATE TABLE **

STREAM NUMBER	RUNOFF (CFS)	Tc (MIN.)	INTENSITY (INCH/HOUR)
1	12.08	5.17	3.105
2	12.27	5.29	3.065
3	13.14	5.82	2.909
4	13.45	6.00	2.862
5	14.52	6.62	2.712
6	14.53	6.62	2.710
7	14.86	6.93	2.643
8	14.77	6.94	2.642
9	14.98	7.24	2.580
10	15.05	7.45	2.540
11	15.05	7.47	2.537
12	15.06	7.62	2.509
13	15.08	7.68	2.498
14	14.97	7.99	2.445
15	14.54	9.00	2.290
16	14.53	9.02	2.288
17	10.36	16.19	1.659

COMPUTED CONFLUENCE ESTIMATES ARE AS FOLLOWS:

PEAK FLOW RATE(CFS) = 15.08 Tc(MIN.) = 7.68
TOTAL AREA(ACRES) = 6.7

FLOW PROCESS FROM NODE 58.00 TO NODE 58.00 IS CODE = 12

>>>>CLEAR MEMORY BANK # 1 <<<<<

FLOW PROCESS FROM NODE 58.00 TO NODE 59.00 IS CODE = 41

>>>>COMPUTE PIPE-FLOW TRAVEL TIME THRU SUBAREA<<<<<
>>>>USING USER-SPECIFIED PIPESIZE (EXISTING ELEMENT)<<<<<

REPRESENTATIVE SLOPE = 0.0040
 FLOW LENGTH(FEET) = 109.46 MANNING'S N = 0.013
 DEPTH OF FLOW IN 36.0 INCH PIPE IS 15.1 INCHES
 PIPE-FLOW VELOCITY(FEET/SEC.) = 5.37
 GIVEN PIPE DIAMETER(INCH) = 36.00 NUMBER OF PIPES = 1
 PIPE-FLOW(CFS) = 15.08
 PIPE TRAVEL TIME(MIN.) = 0.34 Tc(MIN.) = 8.02
 LONGEST FLOWPATH FROM NODE 9.00 TO NODE 59.00 = 1162.22 FEET.

=====
 END OF STUDY SUMMARY:

TOTAL AREA(ACRES) = 6.7 TC(MIN.) = 8.02
 PEAK FLOW RATE(CFS) = 15.08

*** PEAK FLOW RATE TABLE ***

	Q(CFS)	Tc(MIN.)
1	12.08	5.53
2	12.27	5.65
3	13.14	6.17
4	13.45	6.35
5	14.52	6.96
6	14.53	6.97
7	14.86	7.27
8	14.77	7.28
9	14.98	7.58
10	15.05	7.79
11	15.05	7.81
12	15.06	7.96
13	15.08	8.02
14	14.97	8.33
15	14.54	9.34
16	14.53	9.36
17	10.36	16.56

=====
 END OF RATIONAL METHOD ANALYSIS



RATIONAL METHOD HYDROLOGY COMPUTER PROGRAM BASED ON
RIVERSIDE COUNTY FLOOD CONTROL & WATER CONSERVATION DISTRICT
(RCFC&WCD) 1978 HYDROLOGY MANUAL
(c) Copyright 1982-2016 Advanced Engineering Software (aes)
(Rational Tabling Version 23.0)
Release Date: 07/01/2016 License ID 1681

Analysis prepared by:

KHR Associates
17530 Von Karman Avenue
Irvine, CA 92626

***** DESCRIPTION OF STUDY *****

- * IRON LOFTS *
 - * POST-DEVELOPMENT HYDROLOGY - ON-SITE ONLY *
 - * 100-YEAR STORM EVENT *
- *****

FILE NAME: RIL1-S10.DAT
TIME/DATE OF STUDY: 12:44 08/02/2024

USER SPECIFIED HYDROLOGY AND HYDRAULIC MODEL INFORMATION:

USER SPECIFIED STORM EVENT(YEAR) = 100.00
SPECIFIED MINIMUM PIPE SIZE(INCH) = 4.00
SPECIFIED PERCENT OF GRADIENTS(DECIMAL) TO USE FOR FRICTION SLOPE = 0.95
10-YEAR STORM 10-MINUTE INTENSITY(INCH/HOUR) = 2.140
10-YEAR STORM 60-MINUTE INTENSITY(INCH/HOUR) = 0.800
100-YEAR STORM 10-MINUTE INTENSITY(INCH/HOUR) = 3.210
100-YEAR STORM 60-MINUTE INTENSITY(INCH/HOUR) = 1.200
SLOPE OF 10-YEAR INTENSITY-DURATION CURVE = 0.5491525
SLOPE OF 100-YEAR INTENSITY-DURATION CURVE = 0.5491524

COMPUTED RAINFALL INTENSITY DATA:

STORM EVENT = 100.00 1-HOUR INTENSITY(INCH/HOUR) = 1.200
SLOPE OF INTENSITY DURATION CURVE = 0.5492

RCFC&WCD HYDROLOGY MANUAL "C"-VALUES USED FOR RATIONAL METHOD

NOTE: CONSIDER ALL CONFLUENCE STREAM COMBINATIONS

FOR ALL DOWNSTREAM ANALYSES

USER-DEFINED STREET-SECTIONS FOR COUPLED PIPEFLOW AND STREETFLOW MODEL

NO.	HALF-WIDTH (FT)	CROWN TO CROSSFALL (FT)	STREET-CROSSFALL IN-SIDE / OUT-SIDE/PARK-WAY	CURB HEIGHT (FT)	GUTTER WIDTH (FT)	GEOMETRIES LIP (FT)	MANNING HIKE (FT)	FACTOR (n)
1	30.0	20.0	0.018/0.018/0.020	0.67	2.00	0.0313	0.167	0.0150

GLOBAL STREET FLOW-DEPTH CONSTRAINTS:

1. Relative Flow-Depth = 0.00 FEET
as (Maximum Allowable Street Flow Depth) - (Top-of-Curb)
 2. (Depth)*(Velocity) Constraint = 6.0 (FT*FT/S)
- *SIZE PIPE WITH A FLOW CAPACITY GREATER THAN
OR EQUAL TO THE UPSTREAM TRIBUTARY PIPE.*

FLOW PROCESS FROM NODE 1.00 TO NODE 2.00 IS CODE = 21

>>>>RATIONAL METHOD INITIAL SUBAREA ANALYSIS<<<<<

=====

ASSUMED INITIAL SUBAREA UNIFORM
DEVELOPMENT IS APARTMENT

TC = $K * [(LENGTH^{**3}) / (ELEVATION CHANGE)]^{** .2}$
 INITIAL SUBAREA FLOW-LENGTH(FEET) = 124.00
 UPSTREAM ELEVATION(FEET) = 879.50
 DOWNSTREAM ELEVATION(FEET) = 877.89
 ELEVATION DIFFERENCE(FEET) = 1.61
 TC = $0.323 * [(124.00^{**3}) / (1.61)]^{** .2} = 5.290$
 100 YEAR RAINFALL INTENSITY(INCH/HOUR) = 4.554
 APARTMENT DEVELOPMENT RUNOFF COEFFICIENT = .8791
 SOIL CLASSIFICATION IS "C"
 SUBAREA RUNOFF(CFS) = 1.48
 TOTAL AREA(ACRES) = 0.37 TOTAL RUNOFF(CFS) = 1.48

FLOW PROCESS FROM NODE 2.00 TO NODE 2.00 IS CODE = 10

>>>>MAIN-STREAM MEMORY COPIED ONTO MEMORY BANK # 1 <<<<<

FLOW PROCESS FROM NODE 2.00 TO NODE 2.00 IS CODE = 13

>>>>CLEAR THE MAIN-STREAM MEMORY<<<<<

FLOW PROCESS FROM NODE 3.00 TO NODE 4.00 IS CODE = 21

>>>>RATIONAL METHOD INITIAL SUBAREA ANALYSIS<<<<<

=====

ASSUMED INITIAL SUBAREA UNIFORM
DEVELOPMENT IS APARTMENT

TC = $K * [(LENGTH^{**3}) / (ELEVATION CHANGE)]^{** .2}$
 INITIAL SUBAREA FLOW-LENGTH(FEET) = 93.44
 UPSTREAM ELEVATION(FEET) = 15.00
 DOWNSTREAM ELEVATION(FEET) = 13.00
 ELEVATION DIFFERENCE(FEET) = 2.00
 TC = $0.323 * [(93.44^{**3}) / (2.00)]^{** .2} = 4.275$

COMPUTED TIME OF CONCENTRATION INCREASED TO 5 MIN.

100 YEAR RAINFALL INTENSITY(INCH/HOUR) = 4.697

APARTMENT DEVELOPMENT RUNOFF COEFFICIENT = .8796

SOIL CLASSIFICATION IS "C"

SUBAREA RUNOFF(CFS) = 1.00

TOTAL AREA(ACRES) = 0.24 TOTAL RUNOFF(CFS) = 1.00

FLOW PROCESS FROM NODE 4.00 TO NODE 4.10 IS CODE = 41

>>>>COMPUTE PIPE-FLOW TRAVEL TIME THRU SUBAREA<<<<<

>>>>USING USER-SPECIFIED PIPESIZE (EXISTING ELEMENT)<<<<<

REPRESENTATIVE SLOPE = 0.0100

FLOW LENGTH(FEET) = 59.80 MANNING'S N = 0.009

ASSUME FULL-FLOWING PIPELINE

PIPE-FLOW VELOCITY(FEET/SEC.) = 5.11

PIPE FLOW VELOCITY = (TOTAL FLOW)/(PIPE CROSS SECTION AREA)

GIVEN PIPE DIAMETER(INCH) = 6.00 NUMBER OF PIPES = 1

PIPE-FLOW(CFS) = 1.00

PIPE TRAVEL TIME(MIN.) = 0.19 Tc(MIN.) = 5.19

LONGEST FLOWPATH FROM NODE 3.00 TO NODE 4.10 = 153.24 FEET.

FLOW PROCESS FROM NODE 4.10 TO NODE 5.00 IS CODE = 41

>>>>COMPUTE PIPE-FLOW TRAVEL TIME THRU SUBAREA<<<<<

>>>>USING USER-SPECIFIED PIPESIZE (EXISTING ELEMENT)<<<<<

REPRESENTATIVE SLOPE = 0.0100

FLOW LENGTH(FEET) = 13.79 MANNING'S N = 0.009

DEPTH OF FLOW IN 8.0 INCH PIPE IS 4.4 INCHES

PIPE-FLOW VELOCITY(FEET/SEC.) = 5.07

GIVEN PIPE DIAMETER(INCH) = 8.00 NUMBER OF PIPES = 1

PIPE-FLOW(CFS) = 1.00

PIPE TRAVEL TIME(MIN.) = 0.05 Tc(MIN.) = 5.24

LONGEST FLOWPATH FROM NODE 3.00 TO NODE 5.00 = 167.03 FEET.

FLOW PROCESS FROM NODE 5.00 TO NODE 5.00 IS CODE = 10

>>>>MAIN-STREAM MEMORY COPIED ONTO MEMORY BANK # 2 <<<<<

FLOW PROCESS FROM NODE 5.00 TO NODE 5.00 IS CODE = 13

>>>>CLEAR THE MAIN-STREAM MEMORY<<<<<

FLOW PROCESS FROM NODE 6.00 TO NODE 7.00 IS CODE = 21

>>>>RATIONAL METHOD INITIAL SUBAREA ANALYSIS<<<<<

ASSUMED INITIAL SUBAREA UNIFORM DEVELOPMENT IS APARTMENT

TC = K*[(LENGTH**3)/(ELEVATION CHANGE)]**.2
INITIAL SUBAREA FLOW-LENGTH(FEET) = 94.00
UPSTREAM ELEVATION(FEET) = 15.00
DOWNSTREAM ELEVATION(FEET) = 13.00
ELEVATION DIFFERENCE(FEET) = 2.00
TC = 0.323*[(94.00**3)/(2.00)]**.2 = 4.290
COMPUTED TIME OF CONCENTRATION INCREASED TO 5 MIN.
100 YEAR RAINFALL INTENSITY(INCH/HOUR) = 4.697
APARTMENT DEVELOPMENT RUNOFF COEFFICIENT = .8796
SOIL CLASSIFICATION IS "C"
SUBAREA RUNOFF(CFS) = 0.83
TOTAL AREA(ACRES) = 0.20 TOTAL RUNOFF(CFS) = 0.83

FLOW PROCESS FROM NODE 7.00 TO NODE 5.00 IS CODE = 41

>>>>COMPUTE PIPE-FLOW TRAVEL TIME THRU SUBAREA<<<<<
>>>>USING USER-SPECIFIED PIPESIZE (EXISTING ELEMENT)<<<<<

REPRESENTATIVE SLOPE = 0.0100
FLOW LENGTH(FEET) = 12.57 MANNING'S N = 0.009
ASSUME FULL-FLOWING PIPELINE
PIPE-FLOW VELOCITY(FEET/SEC.) = 9.52
PIPE FLOW VELOCITY = (TOTAL FLOW)/(PIPE CROSS SECTION AREA)
GIVEN PIPE DIAMETER(INCH) = 4.00 NUMBER OF PIPES = 1
PIPE-FLOW(CFS) = 0.83
PIPE TRAVEL TIME(MIN.) = 0.02 Tc(MIN.) = 5.02
LONGEST FLOWPATH FROM NODE 6.00 TO NODE 5.00 = 106.57 FEET.

FLOW PROCESS FROM NODE 5.00 TO NODE 5.00 IS CODE = 11

>>>>CONFLUENCE MEMORY BANK # 2 WITH THE MAIN-STREAM MEMORY<<<<<

** MAIN STREAM CONFLUENCE DATA **

STREAM RUNOFF Tc INTENSITY AREA
NUMBER (CFS) (MIN.) (INCH/HOUR) (ACRE)
1 0.83 5.02 4.686 0.20
LONGEST FLOWPATH FROM NODE 6.00 TO NODE 5.00 = 106.57 FEET.

** MEMORY BANK # 2 CONFLUENCE DATA **

STREAM RUNOFF Tc INTENSITY AREA

NUMBER	(CFS)	(MIN.)	(INCH/HOUR)	(ACRE)	
1	1.00	5.24	4.577	0.24	

LONGEST FLOWPATH FROM NODE 3.00 TO NODE 5.00 = 167.03 FEET.

** PEAK FLOW RATE TABLE **

STREAM NUMBER	RUNOFF (CFS)	Tc (MIN.)	INTENSITY (INCH/HOUR)
1	1.79	5.02	4.686
2	1.82	5.24	4.577

COMPUTED CONFLUENCE ESTIMATES ARE AS FOLLOWS:

PEAK FLOW RATE(CFS) = 1.82 Tc(MIN.) = 5.24
TOTAL AREA(ACRES) = 0.4

FLOW PROCESS FROM NODE 5.00 TO NODE 5.00 IS CODE = 12

>>>>CLEAR MEMORY BANK # 2 <<<<<

FLOW PROCESS FROM NODE 7.10 TO NODE 7.10 IS CODE = 81

>>>>ADDITION OF SUBAREA TO MAINLINE PEAK FLOW<<<<<

100 YEAR RAINFALL INTENSITY(INCH/HOUR) = 4.577
UNDEVELOPED WATERSHED RUNOFF COEFFICIENT = .7959
SOIL CLASSIFICATION IS "C"
SUBAREA AREA(ACRES) = 0.10 SUBAREA RUNOFF(CFS) = 0.37
TOTAL AREA(ACRES) = 0.5 TOTAL RUNOFF(CFS) = 2.19
TC(MIN.) = 5.24

FLOW PROCESS FROM NODE 5.00 TO NODE 2.00 IS CODE = 41

>>>>COMPUTE PIPE-FLOW TRAVEL TIME THRU SUBAREA<<<<<
>>>>USING USER-SPECIFIED PIPESIZE (EXISTING ELEMENT)<<<<<

REPRESENTATIVE SLOPE = 0.0100
FLOW LENGTH(FEET) = 78.38 MANNING'S N = 0.009
ASSUME FULL-FLOWING PIPELINE
PIPE-FLOW VELOCITY(FEET/SEC.) = 6.26
PIPE FLOW VELOCITY = (TOTAL FLOW)/(PIPE CROSS SECTION AREA)
GIVEN PIPE DIAMETER(INCH) = 8.00 NUMBER OF PIPES = 1
PIPE-FLOW(CFS) = 2.19
PIPE TRAVEL TIME(MIN.) = 0.21 Tc(MIN.) = 5.45
LONGEST FLOWPATH FROM NODE 3.00 TO NODE 2.00 = 245.41 FEET.

FLOW PROCESS FROM NODE 2.00 TO NODE 2.00 IS CODE = 11

>>>>CONFLUENCE MEMORY BANK # 1 WITH THE MAIN-STREAM MEMORY<<<<<
=====

** MAIN STREAM CONFLUENCE DATA **

STREAM NUMBER	RUNOFF (CFS)	Tc (MIN.)	INTENSITY (INCH/HOUR)	AREA (ACRE)
1	2.17	5.23	4.582	0.55
2	2.19	5.45	4.480	0.55

LONGEST FLOWPATH FROM NODE 3.00 TO NODE 2.00 = 245.41 FEET.

** MEMORY BANK # 1 CONFLUENCE DATA **

STREAM NUMBER	RUNOFF (CFS)	Tc (MIN.)	INTENSITY (INCH/HOUR)	AREA (ACRE)
1	1.48	5.29	4.554	0.37

LONGEST FLOWPATH FROM NODE 1.00 TO NODE 2.00 = 124.00 FEET.

** PEAK FLOW RATE TABLE **

STREAM NUMBER	RUNOFF (CFS)	Tc (MIN.)	INTENSITY (INCH/HOUR)
1	3.64	5.23	4.582
2	3.64	5.29	4.554
3	3.64	5.45	4.480

COMPUTED CONFLUENCE ESTIMATES ARE AS FOLLOWS:

PEAK FLOW RATE(CFS) = 3.64 Tc(MIN.) = 5.45
TOTAL AREA(ACRES) = 0.9

FLOW PROCESS FROM NODE 2.00 TO NODE 2.00 IS CODE = 12

>>>>CLEAR MEMORY BANK # 1 <<<<<
=====

FLOW PROCESS FROM NODE 2.00 TO NODE 8.00 IS CODE = 41

>>>>COMPUTE PIPE-FLOW TRAVEL TIME THRU SUBAREA<<<<<
>>>>USING USER-SPECIFIED PIPESIZE (EXISTING ELEMENT)<<<<<
=====

REPRESENTATIVE SLOPE = 0.0100
FLOW LENGTH(FEET) = 145.73 MANNING'S N = 0.009
ASSUME FULL-FLOWING PIPELINE
PIPE-FLOW VELOCITY(FEET/SEC.) = 6.68
PIPE FLOW VELOCITY = (TOTAL FLOW)/(PIPE CROSS SECTION AREA)
GIVEN PIPE DIAMETER(INCH) = 10.00 NUMBER OF PIPES = 1
PIPE-FLOW(CFS) = 3.64
PIPE TRAVEL TIME(MIN.) = 0.36 Tc(MIN.) = 5.81
LONGEST FLOWPATH FROM NODE 3.00 TO NODE 8.00 = 391.14 FEET.

FLOW PROCESS FROM NODE 8.00 TO NODE 8.00 IS CODE = 10

>>>>MAIN-STREAM MEMORY COPIED ONTO MEMORY BANK # 1 <<<<<
=====

FLOW PROCESS FROM NODE 8.00 TO NODE 8.00 IS CODE = 13

>>>>CLEAR THE MAIN-STREAM MEMORY<<<<<
=====

FLOW PROCESS FROM NODE 9.00 TO NODE 10.00 IS CODE = 21

>>>>RATIONAL METHOD INITIAL SUBAREA ANALYSIS<<<<<
=====

ASSUMED INITIAL SUBAREA UNIFORM
DEVELOPMENT IS APARTMENT
TC = K*[(LENGTH**3)/(ELEVATION CHANGE)]**.2
INITIAL SUBAREA FLOW-LENGTH(FEET) = 71.61
UPSTREAM ELEVATION(FEET) = 15.00
DOWNSTREAM ELEVATION(FEET) = 13.00
ELEVATION DIFFERENCE(FEET) = 2.00
TC = 0.323*[(71.61**3)/(2.00)]**.2 = 3.644
COMPUTED TIME OF CONCENTRATION INCREASED TO 5 MIN.
100 YEAR RAINFALL INTENSITY(INCH/HOUR) = 4.697
APARTMENT DEVELOPMENT RUNOFF COEFFICIENT = .8796
SOIL CLASSIFICATION IS "C"
SUBAREA RUNOFF(CFS) = 0.84
TOTAL AREA(ACRES) = 0.20 TOTAL RUNOFF(CFS) = 0.84

FLOW PROCESS FROM NODE 10.00 TO NODE 10.10 IS CODE = 41

>>>>COMPUTE PIPE-FLOW TRAVEL TIME THRU SUBAREA<<<<<
>>>>USING USER-SPECIFIED PIPESIZE (EXISTING ELEMENT)<<<<<
=====

REPRESENTATIVE SLOPE = 0.0100
FLOW LENGTH(FEET) = 45.35 MANNING'S N = 0.009
ASSUME FULL-FLOWING PIPELINE
PIPE-FLOW VELOCITY(FEET/SEC.) = 9.61
PIPE FLOW VELOCITY = (TOTAL FLOW)/(PIPE CROSS SECTION AREA)
GIVEN PIPE DIAMETER(INCH) = 4.00 NUMBER OF PIPES = 1
PIPE-FLOW(CFS) = 0.84
PIPE TRAVEL TIME(MIN.) = 0.08 Tc(MIN.) = 5.08
LONGEST FLOWPATH FROM NODE 9.00 TO NODE 10.10 = 116.96 FEET.

FLOW PROCESS FROM NODE 10.10 TO NODE 10.20 IS CODE = 41

>>>>COMPUTE PIPE-FLOW TRAVEL TIME THRU SUBAREA<<<<<
>>>>USING USER-SPECIFIED PIPESIZE (EXISTING ELEMENT)<<<<<

=====

REPRESENTATIVE SLOPE = 0.0100
FLOW LENGTH(FEET) = 37.68 MANNING'S N = 0.009
ASSUME FULL-FLOWING PIPELINE
PIPE-FLOW VELOCITY(FEET/SEC.) = 4.27
PIPE FLOW VELOCITY = (TOTAL FLOW)/(PIPE CROSS SECTION AREA)
GIVEN PIPE DIAMETER(INCH) = 6.00 NUMBER OF PIPES = 1
PIPE-FLOW(CFS) = 0.84
PIPE TRAVEL TIME(MIN.) = 0.15 Tc(MIN.) = 5.23
LONGEST FLOWPATH FROM NODE 9.00 TO NODE 10.20 = 154.64 FEET.

FLOW PROCESS FROM NODE 10.20 TO NODE 10.20 IS CODE = 10

>>>>MAIN-STREAM MEMORY COPIED ONTO MEMORY BANK # 3 <<<<<

=====

FLOW PROCESS FROM NODE 10.20 TO NODE 10.20 IS CODE = 13

>>>>CLEAR THE MAIN-STREAM MEMORY<<<<<

=====

FLOW PROCESS FROM NODE 10.30 TO NODE 10.40 IS CODE = 21

>>>>RATIONAL METHOD INITIAL SUBAREA ANALYSIS<<<<<

=====

ASSUMED INITIAL SUBAREA UNIFORM
DEVELOPMENT IS: UNDEVELOPED WITH GOOD COVER
TC = K*[(LENGTH**3)/(ELEVATION CHANGE)]**.2
INITIAL SUBAREA FLOW-LENGTH(FEET) = 17.00
UPSTREAM ELEVATION(FEET) = 878.70
DOWNSTREAM ELEVATION(FEET) = 878.32
ELEVATION DIFFERENCE(FEET) = 0.38
TC = 0.937*[(17.00**3)/(0.38)]**.2 = 6.226
100 YEAR RAINFALL INTENSITY(INCH/HOUR) = 4.164
UNDEVELOPED WATERSHED RUNOFF COEFFICIENT = .7868
SOIL CLASSIFICATION IS "C"
SUBAREA RUNOFF(CFS) = 0.28
TOTAL AREA(ACRES) = 0.08 TOTAL RUNOFF(CFS) = 0.28

FLOW PROCESS FROM NODE 10.40 TO NODE 10.20 IS CODE = 41

>>>>COMPUTE PIPE-FLOW TRAVEL TIME THRU SUBAREA<<<<<
>>>>USING USER-SPECIFIED PIPESIZE (EXISTING ELEMENT)<<<<<

```

=====
REPRESENTATIVE SLOPE = 0.0100
FLOW LENGTH(FEET) = 8.88 MANNING'S N = 0.009
ASSUME FULL-FLOWING PIPELINE
PIPE-FLOW VELOCITY(FEET/SEC.) = 3.15
PIPE FLOW VELOCITY = (TOTAL FLOW)/(PIPE CROSS SECTION AREA)
GIVEN PIPE DIAMETER(INCH) = 4.00 NUMBER OF PIPES = 1
PIPE-FLOW(CFS) = 0.28
PIPE TRAVEL TIME(MIN.) = 0.05 Tc(MIN.) = 6.27
LONGEST FLOWPATH FROM NODE 10.30 TO NODE 10.20 = 25.88 FEET.

```

```

FLOW PROCESS FROM NODE 10.20 TO NODE 10.20 IS CODE = 11

```

```

-----
>>>>>CONFLUENCE MEMORY BANK # 3 WITH THE MAIN-STREAM MEMORY<<<<<
=====

```

** MAIN STREAM CONFLUENCE DATA **

STREAM NUMBER	RUNOFF (CFS)	Tc (MIN.)	INTENSITY (INCH/HOUR)	AREA (ACRE)
1	0.28	6.27	4.147	0.08

LONGEST FLOWPATH FROM NODE 10.30 TO NODE 10.20 = 25.88 FEET.

** MEMORY BANK # 3 CONFLUENCE DATA **

STREAM NUMBER	RUNOFF (CFS)	Tc (MIN.)	INTENSITY (INCH/HOUR)	AREA (ACRE)
1	0.84	5.23	4.584	0.20

LONGEST FLOWPATH FROM NODE 9.00 TO NODE 10.20 = 154.64 FEET.

** PEAK FLOW RATE TABLE **

STREAM NUMBER	RUNOFF (CFS)	Tc (MIN.)	INTENSITY (INCH/HOUR)
1	1.07	5.23	4.584
2	1.03	6.27	4.147

COMPUTED CONFLUENCE ESTIMATES ARE AS FOLLOWS:

```

PEAK FLOW RATE(CFS) = 1.07 Tc(MIN.) = 5.23
TOTAL AREA(ACRES) = 0.3

```

```

FLOW PROCESS FROM NODE 10.20 TO NODE 10.20 IS CODE = 12

```

```

-----
>>>>>CLEAR MEMORY BANK # 3 <<<<<
=====

```

```

FLOW PROCESS FROM NODE 10.20 TO NODE 10.50 IS CODE = 41

```

```

-----
>>>>>COMPUTE PIPE-FLOW TRAVEL TIME THRU SUBAREA<<<<<
>>>>>USING USER-SPECIFIED PIPESIZE (EXISTING ELEMENT)<<<<<

```

```

=====
REPRESENTATIVE SLOPE = 0.0100
FLOW LENGTH(FEET) = 131.52 MANNING'S N = 0.009
ASSUME FULL-FLOWING PIPELINE
PIPE-FLOW VELOCITY(FEET/SEC.) = 5.44
PIPE FLOW VELOCITY = (TOTAL FLOW)/(PIPE CROSS SECTION AREA)
GIVEN PIPE DIAMETER(INCH) = 6.00 NUMBER OF PIPES = 1
PIPE-FLOW(CFS) = 1.07
PIPE TRAVEL TIME(MIN.) = 0.40 Tc(MIN.) = 5.63
LONGEST FLOWPATH FROM NODE 9.00 TO NODE 10.50 = 286.16 FEET.

```

```

FLOW PROCESS FROM NODE 10.50 TO NODE 10.50 IS CODE = 81

```

```

-----
>>>>ADDITION OF SUBAREA TO MAINLINE PEAK FLOW<<<<<

```

```

=====
100 YEAR RAINFALL INTENSITY(INCH/HOUR) = 4.401
UNDEVELOPED WATERSHED RUNOFF COEFFICIENT = .7922
SOIL CLASSIFICATION IS "C"
SUBAREA AREA(ACRES) = 0.10 SUBAREA RUNOFF(CFS) = 0.35
TOTAL AREA(ACRES) = 0.4 TOTAL RUNOFF(CFS) = 1.42
TC(MIN.) = 5.63

```

```

FLOW PROCESS FROM NODE 10.50 TO NODE 8.00 IS CODE = 41

```

```

-----
>>>>COMPUTE PIPE-FLOW TRAVEL TIME THRU SUBAREA<<<<<
>>>>USING USER-SPECIFIED PIPESIZE (EXISTING ELEMENT)<<<<<

```

```

=====
REPRESENTATIVE SLOPE = 0.0100
FLOW LENGTH(FEET) = 137.41 MANNING'S N = 0.009
DEPTH OF FLOW IN 8.0 INCH PIPE IS 5.6 INCHES
PIPE-FLOW VELOCITY(FEET/SEC.) = 5.47
GIVEN PIPE DIAMETER(INCH) = 8.00 NUMBER OF PIPES = 1
PIPE-FLOW(CFS) = 1.42
PIPE TRAVEL TIME(MIN.) = 0.42 Tc(MIN.) = 6.05
LONGEST FLOWPATH FROM NODE 9.00 TO NODE 8.00 = 423.57 FEET.

```

```

FLOW PROCESS FROM NODE 8.00 TO NODE 8.00 IS CODE = 11

```

```

-----
>>>>CONFLUENCE MEMORY BANK # 1 WITH THE MAIN-STREAM MEMORY<<<<<

```

```

=====
** MAIN STREAM CONFLUENCE DATA **

```

STREAM NUMBER	RUNOFF (CFS)	Tc (MIN.)	INTENSITY (INCH/HOUR)	AREA (ACRE)
1	1.42	6.05	4.231	0.39
2	1.35	7.11	3.870	0.39

```

LONGEST FLOWPATH FROM NODE 9.00 TO NODE 8.00 = 423.57 FEET.

```

** MEMORY BANK # 1 CONFLUENCE DATA **

STREAM NUMBER	RUNOFF (CFS)	Tc (MIN.)	INTENSITY (INCH/HOUR)	AREA (ACRE)
1	3.64	5.60	4.415	0.92
2	3.64	5.65	4.390	0.92
3	3.64	5.81	4.324	0.92

LONGEST FLOWPATH FROM NODE 3.00 TO NODE 8.00 = 391.14 FEET.

** PEAK FLOW RATE TABLE **

STREAM NUMBER	RUNOFF (CFS)	Tc (MIN.)	INTENSITY (INCH/HOUR)
1	4.95	5.60	4.415
2	4.97	5.65	4.390
3	5.01	5.81	4.324
4	4.98	6.05	4.231
5	4.61	7.11	3.870

COMPUTED CONFLUENCE ESTIMATES ARE AS FOLLOWS:

PEAK FLOW RATE(CFS) = 5.01 Tc(MIN.) = 5.81
TOTAL AREA(ACRES) = 1.3

FLOW PROCESS FROM NODE 8.00 TO NODE 8.00 IS CODE = 12

>>>>CLEAR MEMORY BANK # 1 <<<<<

FLOW PROCESS FROM NODE 8.00 TO NODE 13.00 IS CODE = 41

>>>>COMPUTE PIPE-FLOW TRAVEL TIME THRU SUBAREA<<<<<
>>>>USING USER-SPECIFIED PIPESIZE (EXISTING ELEMENT)<<<<<

REPRESENTATIVE SLOPE = 0.0100
FLOW LENGTH(FEET) = 38.12 MANNING'S N = 0.009
ASSUME FULL-FLOWING PIPELINE
PIPE-FLOW VELOCITY(FEET/SEC.) = 9.18
PIPE FLOW VELOCITY = (TOTAL FLOW)/(PIPE CROSS SECTION AREA)
GIVEN PIPE DIAMETER(INCH) = 10.00 NUMBER OF PIPES = 1
PIPE-FLOW(CFS) = 5.01
PIPE TRAVEL TIME(MIN.) = 0.07 Tc(MIN.) = 5.88
LONGEST FLOWPATH FROM NODE 9.00 TO NODE 13.00 = 461.69 FEET.

FLOW PROCESS FROM NODE 13.00 TO NODE 13.00 IS CODE = 10

>>>>MAIN-STREAM MEMORY COPIED ONTO MEMORY BANK # 1 <<<<<

FLOW PROCESS FROM NODE 13.00 TO NODE 13.00 IS CODE = 13

>>>>CLEAR THE MAIN-STREAM MEMORY<<<<<

FLOW PROCESS FROM NODE 11.00 TO NODE 12.00 IS CODE = 21

>>>>RATIONAL METHOD INITIAL SUBAREA ANALYSIS<<<<<

ASSUMED INITIAL SUBAREA UNIFORM DEVELOPMENT IS APARTMENT

TC = K*[(LENGTH**3)/(ELEVATION CHANGE)]**.2

INITIAL SUBAREA FLOW-LENGTH(FEET) = 36.94

UPSTREAM ELEVATION(FEET) = 15.00

DOWNSTREAM ELEVATION(FEET) = 13.00

ELEVATION DIFFERENCE(FEET) = 2.00

TC = 0.323*[(36.94**3)/(2.00)]**.2 = 2.450

COMPUTED TIME OF CONCENTRATION INCREASED TO 5 MIN.

100 YEAR RAINFALL INTENSITY(INCH/HOUR) = 4.697

APARTMENT DEVELOPMENT RUNOFF COEFFICIENT = .8796

SOIL CLASSIFICATION IS "C"

SUBAREA RUNOFF(CFS) = 0.21

TOTAL AREA(ACRES) = 0.05 TOTAL RUNOFF(CFS) = 0.21

FLOW PROCESS FROM NODE 12.00 TO NODE 13.00 IS CODE = 41

>>>>COMPUTE PIPE-FLOW TRAVEL TIME THRU SUBAREA<<<<<

>>>>USING USER-SPECIFIED PIPESIZE (EXISTING ELEMENT)<<<<<

REPRESENTATIVE SLOPE = 0.0100

FLOW LENGTH(FEET) = 41.32 MANNING'S N = 0.009

DEPTH OF FLOW IN 4.0 INCH PIPE IS 2.7 INCHES

PIPE-FLOW VELOCITY(FEET/SEC.) = 3.34

GIVEN PIPE DIAMETER(INCH) = 4.00 NUMBER OF PIPES = 1

PIPE-FLOW(CFS) = 0.21

PIPE TRAVEL TIME(MIN.) = 0.21 Tc(MIN.) = 5.21

LONGEST FLOWPATH FROM NODE 11.00 TO NODE 13.00 = 78.26 FEET.

FLOW PROCESS FROM NODE 13.00 TO NODE 13.00 IS CODE = 11

>>>>CONFLUENCE MEMORY BANK # 1 WITH THE MAIN-STREAM MEMORY<<<<<

** MAIN STREAM CONFLUENCE DATA **

STREAM NUMBER	RUNOFF (CFS)	Tc (MIN.)	INTENSITY (INCH/HOUR)	AREA (ACRE)
---------------	--------------	-----------	-----------------------	-------------

1 0.21 5.21 4.594 0.05
LONGEST FLOWPATH FROM NODE 11.00 TO NODE 13.00 = 78.26 FEET.

** MEMORY BANK # 1 CONFLUENCE DATA **

STREAM NUMBER	RUNOFF (CFS)	Tc (MIN.)	INTENSITY (INCH/HOUR)	AREA (ACRE)
1	4.95	5.67	4.385	1.30
2	4.97	5.72	4.361	1.30
3	5.01	5.88	4.296	1.30
4	4.98	6.12	4.205	1.30
5	4.61	7.19	3.848	1.30

LONGEST FLOWPATH FROM NODE 9.00 TO NODE 13.00 = 461.69 FEET.

** PEAK FLOW RATE TABLE **

STREAM NUMBER	RUNOFF (CFS)	Tc (MIN.)	INTENSITY (INCH/HOUR)
1	4.75	5.21	4.594
2	5.15	5.67	4.385
3	5.16	5.72	4.361
4	5.20	5.88	4.296
5	5.17	6.12	4.205
6	4.78	7.19	3.848

COMPUTED CONFLUENCE ESTIMATES ARE AS FOLLOWS:

PEAK FLOW RATE(CFS) = 5.20 Tc(MIN.) = 5.88
TOTAL AREA(ACRES) = 1.4

FLOW PROCESS FROM NODE 13.00 TO NODE 13.00 IS CODE = 12

>>>>CLEAR MEMORY BANK # 1 <<<<<

FLOW PROCESS FROM NODE 13.00 TO NODE 13.00 IS CODE = 10

>>>>MAIN-STREAM MEMORY COPIED ONTO MEMORY BANK # 1 <<<<<

FLOW PROCESS FROM NODE 13.00 TO NODE 13.00 IS CODE = 13

>>>>CLEAR THE MAIN-STREAM MEMORY<<<<<

FLOW PROCESS FROM NODE 14.00 TO NODE 15.00 IS CODE = 21

>>>>RATIONAL METHOD INITIAL SUBAREA ANALYSIS<<<<<

ASSUMED INITIAL SUBAREA UNIFORM
DEVELOPMENT IS APARTMENT

TC = $K * [(LENGTH^{**3}) / (ELEVATION CHANGE)]^{**0.2}$
 INITIAL SUBAREA FLOW-LENGTH(FEET) = 282.36
 UPSTREAM ELEVATION(FEET) = 881.50
 DOWNSTREAM ELEVATION(FEET) = 877.80
 ELEVATION DIFFERENCE(FEET) = 3.70
 TC = $0.323 * [(282.36^{**3}) / (3.70)]^{**0.2} = 7.339$
 100 YEAR RAINFALL INTENSITY(INCH/HOUR) = 3.804
 APARTMENT DEVELOPMENT RUNOFF COEFFICIENT = .8755
 SOIL CLASSIFICATION IS "C"
 SUBAREA RUNOFF(CFS) = 4.41
 TOTAL AREA(ACRES) = 1.32 TOTAL RUNOFF(CFS) = 4.41

 FLOW PROCESS FROM NODE 15.00 TO NODE 15.00 IS CODE = 11

 >>>>CONFLUENCE MEMORY BANK # 1 WITH THE MAIN-STREAM MEMORY<<<<<
 =====

** MAIN STREAM CONFLUENCE DATA **

STREAM NUMBER	RUNOFF (CFS)	Tc (MIN.)	INTENSITY (INCH/HOUR)	AREA (ACRE)
1	4.41	7.34	3.804	1.32

LONGEST FLOWPATH FROM NODE 14.00 TO NODE 15.00 = 282.36 FEET.

** MEMORY BANK # 1 CONFLUENCE DATA **

STREAM NUMBER	RUNOFF (CFS)	Tc (MIN.)	INTENSITY (INCH/HOUR)	AREA (ACRE)
1	4.75	5.21	4.594	1.35
2	5.15	5.67	4.385	1.35
3	5.16	5.72	4.361	1.35
4	5.20	5.88	4.296	1.35
5	5.17	6.12	4.205	1.35
6	4.78	7.19	3.848	1.35

LONGEST FLOWPATH FROM NODE 9.00 TO NODE 15.00 = 461.69 FEET.

** PEAK FLOW RATE TABLE **

STREAM NUMBER	RUNOFF (CFS)	Tc (MIN.)	INTENSITY (INCH/HOUR)
1	7.88	5.21	4.594
2	8.55	5.67	4.385
3	8.60	5.72	4.361
4	8.73	5.88	4.296
5	8.84	6.12	4.205
6	9.10	7.19	3.848
7	9.13	7.34	3.804

COMPUTED CONFLUENCE ESTIMATES ARE AS FOLLOWS:
 PEAK FLOW RATE(CFS) = 9.13 Tc(MIN.) = 7.34

TOTAL AREA(ACRES) = 2.7

FLOW PROCESS FROM NODE 15.00 TO NODE 15.00 IS CODE = 12

>>>>CLEAR MEMORY BANK # 1 <<<<<

FLOW PROCESS FROM NODE 15.00 TO NODE 15.00 IS CODE = 10

>>>>MAIN-STREAM MEMORY COPIED ONTO MEMORY BANK # 1 <<<<<

FLOW PROCESS FROM NODE 15.00 TO NODE 15.00 IS CODE = 13

>>>>CLEAR THE MAIN-STREAM MEMORY<<<<<

FLOW PROCESS FROM NODE 16.00 TO NODE 17.00 IS CODE = 21

>>>>RATIONAL METHOD INITIAL SUBAREA ANALYSIS<<<<<

ASSUMED INITIAL SUBAREA UNIFORM
DEVELOPMENT IS APARTMENT
TC = $K * [(LENGTH^{**3}) / (ELEVATION CHANGE)]^{** .2}$
INITIAL SUBAREA FLOW-LENGTH(FEET) = 74.23
UPSTREAM ELEVATION(FEET) = 15.00
DOWNSTREAM ELEVATION(FEET) = 13.00
ELEVATION DIFFERENCE(FEET) = 2.00
TC = $0.323 * [(74.23^{**3}) / (2.00)]^{** .2} = 3.723$
COMPUTED TIME OF CONCENTRATION INCREASED TO 5 MIN.
100 YEAR RAINFALL INTENSITY(INCH/HOUR) = 4.697
APARTMENT DEVELOPMENT RUNOFF COEFFICIENT = .8796
SOIL CLASSIFICATION IS "C"
SUBAREA RUNOFF(CFS) = 1.19
TOTAL AREA(ACRES) = 0.29 TOTAL RUNOFF(CFS) = 1.19

FLOW PROCESS FROM NODE 17.00 TO NODE 17.10 IS CODE = 41

>>>>COMPUTE PIPE-FLOW TRAVEL TIME THRU SUBAREA<<<<<
>>>>USING USER-SPECIFIED PIPESIZE (EXISTING ELEMENT)<<<<<

REPRESENTATIVE SLOPE = 0.0100
FLOW LENGTH(FEET) = 15.20 MANNING'S N = 0.009
ASSUME FULL-FLOWING PIPELINE
PIPE-FLOW VELOCITY(FEET/SEC.) = 13.68

PIPE FLOW VELOCITY = (TOTAL FLOW)/(PIPE CROSS SECTION AREA)
GIVEN PIPE DIAMETER(INCH) = 4.00 NUMBER OF PIPES = 1
PIPE-FLOW(CFS) = 1.19
PIPE TRAVEL TIME(MIN.) = 0.02 Tc(MIN.) = 5.02
LONGEST FLOWPATH FROM NODE 16.00 TO NODE 17.10 = 89.43 FEET.

FLOW PROCESS FROM NODE 17.10 TO NODE 18.00 IS CODE = 41

>>>>COMPUTE PIPE-FLOW TRAVEL TIME THRU SUBAREA<<<<<
>>>>USING USER-SPECIFIED PIPESIZE (EXISTING ELEMENT)<<<<<

=====

REPRESENTATIVE SLOPE = 0.0100
FLOW LENGTH(FEET) = 164.51 MANNING'S N = 0.009
DEPTH OF FLOW IN 8.0 INCH PIPE IS 4.9 INCHES
PIPE-FLOW VELOCITY(FEET/SEC.) = 5.27
GIVEN PIPE DIAMETER(INCH) = 8.00 NUMBER OF PIPES = 1
PIPE-FLOW(CFS) = 1.19
PIPE TRAVEL TIME(MIN.) = 0.52 Tc(MIN.) = 5.54
LONGEST FLOWPATH FROM NODE 16.00 TO NODE 18.00 = 253.94 FEET.

FLOW PROCESS FROM NODE 18.00 TO NODE 18.00 IS CODE = 10

>>>>MAIN-STREAM MEMORY COPIED ONTO MEMORY BANK # 2 <<<<<

FLOW PROCESS FROM NODE 18.00 TO NODE 18.00 IS CODE = 13

>>>>CLEAR THE MAIN-STREAM MEMORY<<<<<

FLOW PROCESS FROM NODE 19.00 TO NODE 20.00 IS CODE = 21

>>>>RATIONAL METHOD INITIAL SUBAREA ANALYSIS<<<<<

=====

ASSUMED INITIAL SUBAREA UNIFORM
DEVELOPMENT IS APARTMENT
TC = K*[(LENGTH**3)/(ELEVATION CHANGE)]**.2
INITIAL SUBAREA FLOW-LENGTH(FEET) = 147.00
UPSTREAM ELEVATION(FEET) = 881.00
DOWNSTREAM ELEVATION(FEET) = 878.08
ELEVATION DIFFERENCE(FEET) = 2.92
TC = 0.323*[(147.00**3)/(2.92)]**.2 = 5.201
100 YEAR RAINFALL INTENSITY(INCH/HOUR) = 4.596
APARTMENT DEVELOPMENT RUNOFF COEFFICIENT = .8792
SOIL CLASSIFICATION IS "C"
SUBAREA RUNOFF(CFS) = 1.27

TOTAL AREA(ACRES) = 0.31 TOTAL RUNOFF(CFS) = 1.27

FLOW PROCESS FROM NODE 20.00 TO NODE 20.00 IS CODE = 11

>>>>CONFLUENCE MEMORY BANK # 2 WITH THE MAIN-STREAM MEMORY<<<<<

** MAIN STREAM CONFLUENCE DATA **

STREAM NUMBER	RUNOFF (CFS)	Tc (MIN.)	INTENSITY (INCH/HOUR)	AREA (ACRE)
1	1.27	5.20	4.596	0.31

LONGEST FLOWPATH FROM NODE 19.00 TO NODE 20.00 = 147.00 FEET.

** MEMORY BANK # 2 CONFLUENCE DATA **

STREAM NUMBER	RUNOFF (CFS)	Tc (MIN.)	INTENSITY (INCH/HOUR)	AREA (ACRE)
1	1.19	5.54	4.440	0.29

LONGEST FLOWPATH FROM NODE 16.00 TO NODE 20.00 = 253.94 FEET.

** PEAK FLOW RATE TABLE **

STREAM NUMBER	RUNOFF (CFS)	Tc (MIN.)	INTENSITY (INCH/HOUR)
1	2.39	5.20	4.596
2	2.42	5.54	4.440

COMPUTED CONFLUENCE ESTIMATES ARE AS FOLLOWS:

PEAK FLOW RATE(CFS) = 2.42 Tc(MIN.) = 5.54
TOTAL AREA(ACRES) = 0.6

FLOW PROCESS FROM NODE 20.00 TO NODE 20.00 IS CODE = 12

>>>>CLEAR MEMORY BANK # 2 <<<<<

FLOW PROCESS FROM NODE 20.00 TO NODE 21.00 IS CODE = 41

>>>>COMPUTE PIPE-FLOW TRAVEL TIME THRU SUBAREA<<<<<
>>>>USING USER-SPECIFIED PIPESIZE (EXISTING ELEMENT)<<<<<

REPRESENTATIVE SLOPE = 0.0100
FLOW LENGTH(FEET) = 35.92 MANNING'S N = 0.009
ASSUME FULL-FLOWING PIPELINE
PIPE-FLOW VELOCITY(FEET/SEC.) = 12.34
PIPE FLOW VELOCITY = (TOTAL FLOW)/(PIPE CROSS SECTION AREA)
GIVEN PIPE DIAMETER(INCH) = 6.00 NUMBER OF PIPES = 1
PIPE-FLOW(CFS) = 2.42
PIPE TRAVEL TIME(MIN.) = 0.05 Tc(MIN.) = 5.59

LONGEST FLOWPATH FROM NODE 16.00 TO NODE 21.00 = 289.86 FEET.

FLOW PROCESS FROM NODE 21.00 TO NODE 21.00 IS CODE = 10

>>>>MAIN-STREAM MEMORY COPIED ONTO MEMORY BANK # 2 <<<<<

FLOW PROCESS FROM NODE 21.00 TO NODE 21.00 IS CODE = 13

>>>>CLEAR THE MAIN-STREAM MEMORY<<<<<

FLOW PROCESS FROM NODE 22.00 TO NODE 23.00 IS CODE = 21

>>>>RATIONAL METHOD INITIAL SUBAREA ANALYSIS<<<<<

ASSUMED INITIAL SUBAREA UNIFORM

DEVELOPMENT IS: UNDEVELOPED WITH GOOD COVER

$TC = K * [(LENGTH^{**3}) / (ELEVATION CHANGE)]^{**0.2}$

INITIAL SUBAREA FLOW-LENGTH(FEET) = 77.86

UPSTREAM ELEVATION(FEET) = 881.47

DOWNSTREAM ELEVATION(FEET) = 880.67

ELEVATION DIFFERENCE(FEET) = 0.80

$TC = 0.937 * [(77.86^{**3}) / (0.80)]^{**0.2} = 13.369$

100 YEAR RAINFALL INTENSITY(INCH/HOUR) = 2.737

UNDEVELOPED WATERSHED RUNOFF COEFFICIENT = .7384

SOIL CLASSIFICATION IS "C"

SUBAREA RUNOFF(CFS) = 0.20

TOTAL AREA(ACRES) = 0.10 TOTAL RUNOFF(CFS) = 0.20

FLOW PROCESS FROM NODE 23.00 TO NODE 21.00 IS CODE = 41

>>>>COMPUTE PIPE-FLOW TRAVEL TIME THRU SUBAREA<<<<<

>>>>USING USER-SPECIFIED PIPESIZE (EXISTING ELEMENT)<<<<<

REPRESENTATIVE SLOPE = 0.0100

FLOW LENGTH(FEET) = 107.21 MANNING'S N = 0.009

DEPTH OF FLOW IN 6.0 INCH PIPE IS 2.1 INCHES

PIPE-FLOW VELOCITY(FEET/SEC.) = 3.40

GIVEN PIPE DIAMETER(INCH) = 6.00 NUMBER OF PIPES = 1

PIPE-FLOW(CFS) = 0.20

PIPE TRAVEL TIME(MIN.) = 0.53 T_c (MIN.) = 13.90

LONGEST FLOWPATH FROM NODE 22.00 TO NODE 21.00 = 185.07 FEET.

FLOW PROCESS FROM NODE 21.00 TO NODE 21.00 IS CODE = 11

>>>>>CONFLUENCE MEMORY BANK # 2 WITH THE MAIN-STREAM MEMORY<<<<<<
=====

** MAIN STREAM CONFLUENCE DATA **

STREAM NUMBER	RUNOFF (CFS)	Tc (MIN.)	INTENSITY (INCH/HOUR)	AREA (ACRE)	
1	0.20	13.90	2.679	0.10	
LONGEST FLOWPATH FROM NODE					22.00 TO NODE 21.00 = 185.07 FEET.

** MEMORY BANK # 2 CONFLUENCE DATA **

STREAM NUMBER	RUNOFF (CFS)	Tc (MIN.)	INTENSITY (INCH/HOUR)	AREA (ACRE)	
1	2.39	5.25	4.573	0.60	
2	2.42	5.59	4.419	0.60	
LONGEST FLOWPATH FROM NODE					16.00 TO NODE 21.00 = 289.86 FEET.

** PEAK FLOW RATE TABLE **

STREAM NUMBER	RUNOFF (CFS)	Tc (MIN.)	INTENSITY (INCH/HOUR)
1	2.47	5.25	4.573
2	2.51	5.59	4.419
3	1.67	13.90	2.679

COMPUTED CONFLUENCE ESTIMATES ARE AS FOLLOWS:

PEAK FLOW RATE(CFS) = 2.51 Tc(MIN.) = 5.59
TOTAL AREA(ACRES) = 0.7

FLOW PROCESS FROM NODE 21.00 TO NODE 21.00 IS CODE = 12

>>>>>CLEAR MEMORY BANK # 2 <<<<<<
=====

FLOW PROCESS FROM NODE 21.00 TO NODE 24.00 IS CODE = 41

>>>>>COMPUTE PIPE-FLOW TRAVEL TIME THRU SUBAREA<<<<<<
>>>>>USING USER-SPECIFIED PIPESIZE (EXISTING ELEMENT)<<<<<<
=====

REPRESENTATIVE SLOPE = 0.0100
FLOW LENGTH(FEET) = 136.64 MANNING'S N = 0.009
ASSUME FULL-FLOWING PIPELINE
PIPE-FLOW VELOCITY(FEET/SEC.) = 12.76
PIPE FLOW VELOCITY = (TOTAL FLOW)/(PIPE CROSS SECTION AREA)
GIVEN PIPE DIAMETER(INCH) = 6.00 NUMBER OF PIPES = 1
PIPE-FLOW(CFS) = 2.51
PIPE TRAVEL TIME(MIN.) = 0.18 Tc(MIN.) = 5.77
LONGEST FLOWPATH FROM NODE 16.00 TO NODE 24.00 = 426.50 FEET.

FLOW PROCESS FROM NODE 24.00 TO NODE 24.00 IS CODE = 11

>>>>CONFLUENCE MEMORY BANK # 1 WITH THE MAIN-STREAM MEMORY<<<<<

** MAIN STREAM CONFLUENCE DATA **

STREAM NUMBER	RUNOFF (CFS)	Tc (MIN.)	INTENSITY (INCH/HOUR)	AREA (ACRE)
1	2.47	5.43	4.488	0.70
2	2.51	5.77	4.344	0.70
3	1.67	14.16	2.652	0.70
LONGEST FLOWPATH FROM NODE 16.00 TO NODE 24.00 = 426.50 FEET.				

** MEMORY BANK # 1 CONFLUENCE DATA **

STREAM NUMBER	RUNOFF (CFS)	Tc (MIN.)	INTENSITY (INCH/HOUR)	AREA (ACRE)
1	7.88	5.21	4.594	2.68
2	8.55	5.67	4.385	2.68
3	8.60	5.72	4.361	2.68
4	8.73	5.88	4.296	2.68
5	8.84	6.12	4.205	2.68
6	9.10	7.19	3.848	2.68
7	9.13	7.34	3.804	2.68
LONGEST FLOWPATH FROM NODE 9.00 TO NODE 24.00 = 461.69 FEET.				

** PEAK FLOW RATE TABLE **

STREAM NUMBER	RUNOFF (CFS)	Tc (MIN.)	INTENSITY (INCH/HOUR)
1	10.25	5.21	4.594
2	10.67	5.43	4.488
3	11.01	5.67	4.385
4	11.09	5.72	4.361
5	11.07	5.77	4.344
6	11.21	5.88	4.296
7	11.27	6.12	4.205
8	11.32	7.19	3.848
9	11.33	7.34	3.804
10	8.04	14.16	2.652

COMPUTED CONFLUENCE ESTIMATES ARE AS FOLLOWS:

PEAK FLOW RATE(CFS) = 11.33 Tc(MIN.) = 7.34
TOTAL AREA(ACRES) = 3.4

FLOW PROCESS FROM NODE 24.00 TO NODE 24.00 IS CODE = 12

>>>>CLEAR MEMORY BANK # 1 <<<<<

FLOW PROCESS FROM NODE 24.00 TO NODE 25.00 IS CODE = 41

>>>>COMPUTE PIPE-FLOW TRAVEL TIME THRU SUBAREA<<<<<
>>>>USING USER-SPECIFIED PIPESIZE (EXISTING ELEMENT)<<<<<

=====
REPRESENTATIVE SLOPE = 0.0100
FLOW LENGTH(FEET) = 55.93 MANNING'S N = 0.009
ASSUME FULL-FLOWING PIPELINE
PIPE-FLOW VELOCITY(FEET/SEC.) = 57.70
PIPE FLOW VELOCITY = (TOTAL FLOW)/(PIPE CROSS SECTION AREA)
GIVEN PIPE DIAMETER(INCH) = 6.00 NUMBER OF PIPES = 1
PIPE-FLOW(CFS) = 11.33
PIPE TRAVEL TIME(MIN.) = 0.02 Tc(MIN.) = 7.36
LONGEST FLOWPATH FROM NODE 9.00 TO NODE 25.00 = 517.62 FEET.

FLOW PROCESS FROM NODE 26.00 TO NODE 27.00 IS CODE = 41

>>>>COMPUTE PIPE-FLOW TRAVEL TIME THRU SUBAREA<<<<<
>>>>USING USER-SPECIFIED PIPESIZE (EXISTING ELEMENT)<<<<<

=====
REPRESENTATIVE SLOPE = 0.0040
FLOW LENGTH(FEET) = 255.17 MANNING'S N = 0.010
ASSUME FULL-FLOWING PIPELINE
PIPE-FLOW VELOCITY(FEET/SEC.) = 6.41
PIPE FLOW VELOCITY = (TOTAL FLOW)/(PIPE CROSS SECTION AREA)
GIVEN PIPE DIAMETER(INCH) = 18.00 NUMBER OF PIPES = 1
PIPE-FLOW(CFS) = 11.33
PIPE TRAVEL TIME(MIN.) = 0.66 Tc(MIN.) = 8.02
LONGEST FLOWPATH FROM NODE 9.00 TO NODE 27.00 = 772.79 FEET.

FLOW PROCESS FROM NODE 27.00 TO NODE 27.10 IS CODE = 41

>>>>COMPUTE PIPE-FLOW TRAVEL TIME THRU SUBAREA<<<<<
>>>>USING USER-SPECIFIED PIPESIZE (EXISTING ELEMENT)<<<<<

=====
REPRESENTATIVE SLOPE = 0.0040
FLOW LENGTH(FEET) = 279.97 MANNING'S N = 0.010
ASSUME FULL-FLOWING PIPELINE
PIPE-FLOW VELOCITY(FEET/SEC.) = 6.41
PIPE FLOW VELOCITY = (TOTAL FLOW)/(PIPE CROSS SECTION AREA)
GIVEN PIPE DIAMETER(INCH) = 18.00 NUMBER OF PIPES = 1
PIPE-FLOW(CFS) = 11.33
PIPE TRAVEL TIME(MIN.) = 0.73 Tc(MIN.) = 8.75
LONGEST FLOWPATH FROM NODE 9.00 TO NODE 27.10 = 1052.76 FEET.

FLOW PROCESS FROM NODE 27.10 TO NODE 27.10 IS CODE = 10

```

-----
>>>>MAIN-STREAM MEMORY COPIED ONTO MEMORY BANK # 1 <<<<<
=====
*****
FLOW PROCESS FROM NODE      27.10 TO NODE      27.10 IS CODE = 13
-----
>>>>CLEAR THE MAIN-STREAM MEMORY<<<<<
=====
*****
FLOW PROCESS FROM NODE      27.10 TO NODE      28.00 IS CODE = 41
-----
>>>>COMPUTE PIPE-FLOW TRAVEL TIME THRU SUBAREA<<<<<
>>>>USING USER-SPECIFIED PIPESIZE (EXISTING ELEMENT)<<<<<
=====
REPRESENTATIVE SLOPE = 0.0040
FLOW LENGTH(FEET) = 71.25 MANNING'S N = 0.013
DEPTH OF FLOW IN 36.0 INCH PIPE IS 3.9 INCHES
PIPE-FLOW VELOCITY(FEET/SEC.) = 2.45
GIVEN PIPE DIAMETER(INCH) = 36.00 NUMBER OF PIPES = 1
PIPE-FLOW(CFS) = 1.00
PIPE TRAVEL TIME(MIN.) = 0.49 Tc(MIN.) = 5.49
LONGEST FLOWPATH FROM NODE 9.00 TO NODE 28.00 = 1124.01 FEET.
*****
FLOW PROCESS FROM NODE      28.00 TO NODE      28.00 IS CODE = 10
-----
>>>>MAIN-STREAM MEMORY COPIED ONTO MEMORY BANK # 1 <<<<<
=====
***MEMORY BANK # 1 IS FULL. THEREFORE, MAIN-STREAM MEMORY
DATA CAN NOT BE COPIED ONTO IT - PROCESS IGNORED.***
*****
FLOW PROCESS FROM NODE      28.00 TO NODE      28.00 IS CODE = 13
-----
>>>>CLEAR THE MAIN-STREAM MEMORY<<<<<
=====
*****
FLOW PROCESS FROM NODE      29.00 TO NODE      30.00 IS CODE = 21
-----
>>>>RATIONAL METHOD INITIAL SUBAREA ANALYSIS<<<<<
=====
ASSUMED INITIAL SUBAREA UNIFORM
DEVELOPMENT IS APARTMENT
TC = K*[(LENGTH**3)/(ELEVATION CHANGE)]**.2
INITIAL SUBAREA FLOW-LENGTH(FEET) = 61.88
UPSTREAM ELEVATION(FEET) = 882.80
DOWNSTREAM ELEVATION(FEET) = 882.10

```

ELEVATION DIFFERENCE(FEET) = 0.70
TC = 0.323*[(61.88**3)/(0.70)]**.2 = 4.118
COMPUTED TIME OF CONCENTRATION INCREASED TO 5 MIN.
100 YEAR RAINFALL INTENSITY(INCH/HOUR) = 4.697
APARTMENT DEVELOPMENT RUNOFF COEFFICIENT = .8796
SOIL CLASSIFICATION IS "C"
SUBAREA RUNOFF(CFS) = 0.68
TOTAL AREA(ACRES) = 0.16 TOTAL RUNOFF(CFS) = 0.68

FLOW PROCESS FROM NODE 30.00 TO NODE 31.00 IS CODE = 41

>>>>COMPUTE PIPE-FLOW TRAVEL TIME THRU SUBAREA<<<<<
>>>>USING USER-SPECIFIED PIPESIZE (EXISTING ELEMENT)<<<<<

=====

REPRESENTATIVE SLOPE = 0.0100
FLOW LENGTH(FEET) = 55.57 MANNING'S N = 0.009
ASSUME FULL-FLOWING PIPELINE
PIPE-FLOW VELOCITY(FEET/SEC.) = 7.76
PIPE FLOW VELOCITY = (TOTAL FLOW)/(PIPE CROSS SECTION AREA)
GIVEN PIPE DIAMETER(INCH) = 4.00 NUMBER OF PIPES = 1
PIPE-FLOW(CFS) = 0.68
PIPE TRAVEL TIME(MIN.) = 0.12 Tc(MIN.) = 5.12
LONGEST FLOWPATH FROM NODE 29.00 TO NODE 31.00 = 117.45 FEET.

FLOW PROCESS FROM NODE 31.00 TO NODE 32.00 IS CODE = 41

>>>>COMPUTE PIPE-FLOW TRAVEL TIME THRU SUBAREA<<<<<
>>>>USING USER-SPECIFIED PIPESIZE (EXISTING ELEMENT)<<<<<

=====

REPRESENTATIVE SLOPE = 0.0100
FLOW LENGTH(FEET) = 89.09 MANNING'S N = 0.009
DEPTH OF FLOW IN 6.0 INCH PIPE IS 4.3 INCHES
PIPE-FLOW VELOCITY(FEET/SEC.) = 4.51
GIVEN PIPE DIAMETER(INCH) = 6.00 NUMBER OF PIPES = 1
PIPE-FLOW(CFS) = 0.68
PIPE TRAVEL TIME(MIN.) = 0.33 Tc(MIN.) = 5.45
LONGEST FLOWPATH FROM NODE 29.00 TO NODE 32.00 = 206.54 FEET.

FLOW PROCESS FROM NODE 32.00 TO NODE 33.00 IS CODE = 41

>>>>COMPUTE PIPE-FLOW TRAVEL TIME THRU SUBAREA<<<<<
>>>>USING USER-SPECIFIED PIPESIZE (EXISTING ELEMENT)<<<<<

=====

REPRESENTATIVE SLOPE = 0.0100
FLOW LENGTH(FEET) = 23.50 MANNING'S N = 0.009
DEPTH OF FLOW IN 8.0 INCH PIPE IS 3.5 INCHES
PIPE-FLOW VELOCITY(FEET/SEC.) = 4.58

GIVEN PIPE DIAMETER(INCH) = 8.00 NUMBER OF PIPES = 1
PIPE-FLOW(CFS) = 0.68
PIPE TRAVEL TIME(MIN.) = 0.09 Tc(MIN.) = 5.53
LONGEST FLOWPATH FROM NODE 29.00 TO NODE 33.00 = 230.04 FEET.

FLOW PROCESS FROM NODE 33.00 TO NODE 33.00 IS CODE = 10

>>>>MAIN-STREAM MEMORY COPIED ONTO MEMORY BANK # 3 <<<<<

FLOW PROCESS FROM NODE 33.00 TO NODE 33.00 IS CODE = 13

>>>>CLEAR THE MAIN-STREAM MEMORY<<<<<

FLOW PROCESS FROM NODE 34.00 TO NODE 35.00 IS CODE = 21

>>>>RATIONAL METHOD INITIAL SUBAREA ANALYSIS<<<<<

ASSUMED INITIAL SUBAREA UNIFORM
DEVELOPMENT IS APARTMENT

$TC = K * [(LENGTH^{**3}) / (ELEVATION CHANGE)]^{**0.2}$

INITIAL SUBAREA FLOW-LENGTH(FEET) = 65.92

UPSTREAM ELEVATION(FEET) = 15.00

DOWNSTREAM ELEVATION(FEET) = 13.00

ELEVATION DIFFERENCE(FEET) = 2.00

$TC = 0.323 * [(65.92^{**3}) / (2.00)]^{**0.2} = 3.467$

COMPUTED TIME OF CONCENTRATION INCREASED TO 5 MIN.

100 YEAR RAINFALL INTENSITY(INCH/HOUR) = 4.697

APARTMENT DEVELOPMENT RUNOFF COEFFICIENT = .8796

SOIL CLASSIFICATION IS "C"

SUBAREA RUNOFF(CFS) = 0.38

TOTAL AREA(ACRES) = 0.09 TOTAL RUNOFF(CFS) = 0.38

FLOW PROCESS FROM NODE 35.00 TO NODE 33.00 IS CODE = 41

>>>>COMPUTE PIPE-FLOW TRAVEL TIME THRU SUBAREA<<<<<

>>>>USING USER-SPECIFIED PIPESIZE (EXISTING ELEMENT)<<<<<

REPRESENTATIVE SLOPE = 0.0100

FLOW LENGTH(FEET) = 2.00 MANNING'S N = 0.009

ASSUME FULL-FLOWING PIPELINE

PIPE-FLOW VELOCITY(FEET/SEC.) = 4.40

PIPE FLOW VELOCITY = (TOTAL FLOW)/(PIPE CROSS SECTION AREA)

GIVEN PIPE DIAMETER(INCH) = 4.00 NUMBER OF PIPES = 1

PIPE-FLOW(CFS) = 0.38

PIPE TRAVEL TIME(MIN.) = 0.01 Tc(MIN.) = 5.01
LONGEST FLOWPATH FROM NODE 34.00 TO NODE 33.00 = 67.92 FEET.

FLOW PROCESS FROM NODE 33.00 TO NODE 33.00 IS CODE = 11

>>>>CONFLUENCE MEMORY BANK # 3 WITH THE MAIN-STREAM MEMORY<<<<<

=====
** MAIN STREAM CONFLUENCE DATA **

STREAM NUMBER	RUNOFF (CFS)	Tc (MIN.)	INTENSITY (INCH/HOUR)	AREA (ACRE)
1	0.38	5.01	4.693	0.09

LONGEST FLOWPATH FROM NODE 34.00 TO NODE 33.00 = 67.92 FEET.

** MEMORY BANK # 3 CONFLUENCE DATA **

STREAM NUMBER	RUNOFF (CFS)	Tc (MIN.)	INTENSITY (INCH/HOUR)	AREA (ACRE)
1	0.68	5.53	4.442	0.16

LONGEST FLOWPATH FROM NODE 29.00 TO NODE 33.00 = 230.04 FEET.

** PEAK FLOW RATE TABLE **

STREAM NUMBER	RUNOFF (CFS)	Tc (MIN.)	INTENSITY (INCH/HOUR)
1	1.00	5.01	4.693
2	1.04	5.53	4.442

COMPUTED CONFLUENCE ESTIMATES ARE AS FOLLOWS:

PEAK FLOW RATE(CFS) = 1.04 Tc(MIN.) = 5.53
TOTAL AREA(ACRES) = 0.3

FLOW PROCESS FROM NODE 33.00 TO NODE 33.00 IS CODE = 12

>>>>CLEAR MEMORY BANK # 3 <<<<<

FLOW PROCESS FROM NODE 33.00 TO NODE 36.00 IS CODE = 41

>>>>COMPUTE PIPE-FLOW TRAVEL TIME THRU SUBAREA<<<<<
>>>>USING USER-SPECIFIED PIPESIZE (EXISTING ELEMENT)<<<<<

=====
REPRESENTATIVE SLOPE = 0.0100
FLOW LENGTH(FEET) = 48.57 MANNING'S N = 0.009
DEPTH OF FLOW IN 8.0 INCH PIPE IS 4.5 INCHES
PIPE-FLOW VELOCITY(FEET/SEC.) = 5.11
GIVEN PIPE DIAMETER(INCH) = 8.00 NUMBER OF PIPES = 1
PIPE-FLOW(CFS) = 1.04
PIPE TRAVEL TIME(MIN.) = 0.16 Tc(MIN.) = 5.69

LONGEST FLOWPATH FROM NODE 29.00 TO NODE 36.00 = 278.61 FEET.

FLOW PROCESS FROM NODE 36.00 TO NODE 36.00 IS CODE = 10

>>>>MAIN-STREAM MEMORY COPIED ONTO MEMORY BANK # 3 <<<<<

FLOW PROCESS FROM NODE 34.00 TO NODE 34.00 IS CODE = 13

>>>>CLEAR THE MAIN-STREAM MEMORY<<<<<

FLOW PROCESS FROM NODE 37.00 TO NODE 38.00 IS CODE = 21

>>>>RATIONAL METHOD INITIAL SUBAREA ANALYSIS<<<<<

=====

ASSUMED INITIAL SUBAREA UNIFORM

DEVELOPMENT IS: UNDEVELOPED WITH GOOD COVER

TC = K*[(LENGTH**3)/(ELEVATION CHANGE)]**.2

INITIAL SUBAREA FLOW-LENGTH(FEET) = 47.00

UPSTREAM ELEVATION(FEET) = 879.59

DOWNSTREAM ELEVATION(FEET) = 878.75

ELEVATION DIFFERENCE(FEET) = 0.84

TC = 0.937*[(47.00**3)/(0.84)]**.2 = 9.780

100 YEAR RAINFALL INTENSITY(INCH/HOUR) = 3.250

UNDEVELOPED WATERSHED RUNOFF COEFFICIENT = .7599

SOIL CLASSIFICATION IS "C"

SUBAREA RUNOFF(CFS) = 0.22

TOTAL AREA(ACRES) = 0.09 TOTAL RUNOFF(CFS) = 0.22

FLOW PROCESS FROM NODE 38.00 TO NODE 36.00 IS CODE = 41

>>>>COMPUTE PIPE-FLOW TRAVEL TIME THRU SUBAREA<<<<<

>>>>USING USER-SPECIFIED PIPESIZE (EXISTING ELEMENT)<<<<<

=====

REPRESENTATIVE SLOPE = 0.0100

FLOW LENGTH(FEET) = 14.50 MANNING'S N = 0.009

DEPTH OF FLOW IN 10.0 INCH PIPE IS 1.8 INCHES

PIPE-FLOW VELOCITY(FEET/SEC.) = 3.25

GIVEN PIPE DIAMETER(INCH) = 10.00 NUMBER OF PIPES = 1

PIPE-FLOW(CFS) = 0.22

PIPE TRAVEL TIME(MIN.) = 0.07 Tc(MIN.) = 9.85

LONGEST FLOWPATH FROM NODE 37.00 TO NODE 36.00 = 61.50 FEET.

FLOW PROCESS FROM NODE 36.00 TO NODE 36.00 IS CODE = 11

>>>>CONFLUENCE MEMORY BANK # 3 WITH THE MAIN-STREAM MEMORY<<<<<
=====

** MAIN STREAM CONFLUENCE DATA **

STREAM NUMBER	RUNOFF (CFS)	Tc (MIN.)	INTENSITY (INCH/HOUR)	AREA (ACRE)	
1	0.22	9.85	3.236	0.09	
LONGEST FLOWPATH FROM NODE					37.00 TO NODE 36.00 = 61.50 FEET.

** MEMORY BANK # 3 CONFLUENCE DATA **

STREAM NUMBER	RUNOFF (CFS)	Tc (MIN.)	INTENSITY (INCH/HOUR)	AREA (ACRE)	
1	1.00	5.17	4.613	0.26	
2	1.04	5.69	4.374	0.26	
LONGEST FLOWPATH FROM NODE					29.00 TO NODE 36.00 = 278.61 FEET.

** PEAK FLOW RATE TABLE **

STREAM NUMBER	RUNOFF (CFS)	Tc (MIN.)	INTENSITY (INCH/HOUR)
1	1.11	5.17	4.613
2	1.17	5.69	4.374
3	0.99	9.85	3.236

COMPUTED CONFLUENCE ESTIMATES ARE AS FOLLOWS:

PEAK FLOW RATE(CFS) = 1.17 Tc(MIN.) = 5.69
TOTAL AREA(ACRES) = 0.3

FLOW PROCESS FROM NODE 36.00 TO NODE 39.00 IS CODE = 41

>>>>COMPUTE PIPE-FLOW TRAVEL TIME THRU SUBAREA<<<<<
>>>>USING USER-SPECIFIED PIPESIZE (EXISTING ELEMENT)<<<<<
=====

REPRESENTATIVE SLOPE = 0.0100
FLOW LENGTH(FEET) = 52.84 MANNING'S N = 0.009
DEPTH OF FLOW IN 10.0 INCH PIPE IS 4.3 INCHES
PIPE-FLOW VELOCITY(FEET/SEC.) = 5.27
GIVEN PIPE DIAMETER(INCH) = 10.00 NUMBER OF PIPES = 1
PIPE-FLOW(CFS) = 1.17
PIPE TRAVEL TIME(MIN.) = 0.17 Tc(MIN.) = 5.86
LONGEST FLOWPATH FROM NODE 29.00 TO NODE 39.00 = 331.45 FEET.

FLOW PROCESS FROM NODE 39.00 TO NODE 39.00 IS CODE = 10

>>>>MAIN-STREAM MEMORY COPIED ONTO MEMORY BANK # 3 <<<<<
=====

***MEMORY BANK # 3 IS FULL. THEREFORE, MAIN-STREAM MEMORY
DATA CAN NOT BE COPIED ONTO IT - PROCESS IGNORED.***

FLOW PROCESS FROM NODE 39.00 TO NODE 39.00 IS CODE = 13

>>>>CLEAR THE MAIN-STREAM MEMORY<<<<<
=====

FLOW PROCESS FROM NODE 40.00 TO NODE 41.00 IS CODE = 21

>>>>RATIONAL METHOD INITIAL SUBAREA ANALYSIS<<<<<
=====

ASSUMED INITIAL SUBAREA UNIFORM
DEVELOPMENT IS APARTMENT
TC = $K * [(LENGTH^{**3}) / (ELEVATION CHANGE)]^{** .2}$
INITIAL SUBAREA FLOW-LENGTH(FEET) = 74.92
UPSTREAM ELEVATION(FEET) = 15.00
DOWNSTREAM ELEVATION(FEET) = 13.00
ELEVATION DIFFERENCE(FEET) = 2.00
TC = $0.323 * [(74.92^{**3}) / (2.00)]^{** .2} = 3.744$
COMPUTED TIME OF CONCENTRATION INCREASED TO 5 MIN.
100 YEAR RAINFALL INTENSITY(INCH/HOUR) = 4.697
APARTMENT DEVELOPMENT RUNOFF COEFFICIENT = .8796
SOIL CLASSIFICATION IS "C"
SUBAREA RUNOFF(CFS) = 1.67
TOTAL AREA(ACRES) = 0.40 TOTAL RUNOFF(CFS) = 1.67

FLOW PROCESS FROM NODE 41.00 TO NODE 39.00 IS CODE = 41

>>>>COMPUTE PIPE-FLOW TRAVEL TIME THRU SUBAREA<<<<<
>>>>USING USER-SPECIFIED PIPESIZE (EXISTING ELEMENT)<<<<<
=====

REPRESENTATIVE SLOPE = 0.0100
FLOW LENGTH(FEET) = 7.00 MANNING'S N = 0.009
ASSUME FULL-FLOWING PIPELINE
PIPE-FLOW VELOCITY(FEET/SEC.) = 19.13
PIPE FLOW VELOCITY = (TOTAL FLOW)/(PIPE CROSS SECTION AREA)
GIVEN PIPE DIAMETER(INCH) = 4.00 NUMBER OF PIPES = 1
PIPE-FLOW(CFS) = 1.67
PIPE TRAVEL TIME(MIN.) = 0.01 Tc(MIN.) = 5.01
LONGEST FLOWPATH FROM NODE 40.00 TO NODE 39.00 = 81.92 FEET.

FLOW PROCESS FROM NODE 39.00 TO NODE 39.00 IS CODE = 11

>>>>CONFLUENCE MEMORY BANK # 3 WITH THE MAIN-STREAM MEMORY<<<<<
=====

** MAIN STREAM CONFLUENCE DATA **

STREAM NUMBER	RUNOFF (CFS)	Tc (MIN.)	INTENSITY (INCH/HOUR)	AREA (ACRE)
1	1.67	5.01	4.694	0.40

LONGEST FLOWPATH FROM NODE 40.00 TO NODE 39.00 = 81.92 FEET.

** MEMORY BANK # 3 CONFLUENCE DATA **

STREAM NUMBER	RUNOFF (CFS)	Tc (MIN.)	INTENSITY (INCH/HOUR)	AREA (ACRE)
1	1.00	5.17	4.613	0.26
2	1.04	5.69	4.374	0.26

LONGEST FLOWPATH FROM NODE 29.00 TO NODE 39.00 = 278.61 FEET.

** PEAK FLOW RATE TABLE **

STREAM NUMBER	RUNOFF (CFS)	Tc (MIN.)	INTENSITY (INCH/HOUR)
1	2.64	5.01	4.694
2	2.64	5.17	4.613
3	2.60	5.69	4.374

COMPUTED CONFLUENCE ESTIMATES ARE AS FOLLOWS:
 PEAK FLOW RATE(CFS) = 2.64 Tc(MIN.) = 5.17
 TOTAL AREA(ACRES) = 0.7

 FLOW PROCESS FROM NODE 39.00 TO NODE 39.00 IS CODE = 12

>>>>CLEAR MEMORY BANK # 3 <<<<<

 FLOW PROCESS FROM NODE 39.00 TO NODE 42.00 IS CODE = 41

>>>>COMPUTE PIPE-FLOW TRAVEL TIME THRU SUBAREA<<<<<
 >>>>USING USER-SPECIFIED PIPESIZE (EXISTING ELEMENT)<<<<<

=====

REPRESENTATIVE SLOPE = 0.0100
 FLOW LENGTH(FEET) = 52.87 MANNING'S N = 0.009
 DEPTH OF FLOW IN 10.0 INCH PIPE IS 7.1 INCHES
 PIPE-FLOW VELOCITY(FEET/SEC.) = 6.35
 GIVEN PIPE DIAMETER(INCH) = 10.00 NUMBER OF PIPES = 1
 PIPE-FLOW(CFS) = 2.64
 PIPE TRAVEL TIME(MIN.) = 0.14 Tc(MIN.) = 5.31
 LONGEST FLOWPATH FROM NODE 29.00 TO NODE 42.00 = 331.48 FEET.

 FLOW PROCESS FROM NODE 42.00 TO NODE 43.00 IS CODE = 41

>>>>COMPUTE PIPE-FLOW TRAVEL TIME THRU SUBAREA<<<<<
 >>>>USING USER-SPECIFIED PIPESIZE (EXISTING ELEMENT)<<<<<

=====

REPRESENTATIVE SLOPE = 0.0100
FLOW LENGTH(FEET) = 91.61 MANNING'S N = 0.010
DEPTH OF FLOW IN 12.0 INCH PIPE IS 6.6 INCHES
PIPE-FLOW VELOCITY(FEET/SEC.) = 5.97
GIVEN PIPE DIAMETER(INCH) = 12.00 NUMBER OF PIPES = 1
PIPE-FLOW(CFS) = 2.64
PIPE TRAVEL TIME(MIN.) = 0.26 Tc(MIN.) = 5.56
LONGEST FLOWPATH FROM NODE 29.00 TO NODE 43.00 = 423.09 FEET.

FLOW PROCESS FROM NODE 43.00 TO NODE 43.00 IS CODE = 10

>>>>MAIN-STREAM MEMORY COPIED ONTO MEMORY BANK # 3 <<<<<
=====

FLOW PROCESS FROM NODE 43.00 TO NODE 43.00 IS CODE = 13

>>>>CLEAR THE MAIN-STREAM MEMORY<<<<<
=====

FLOW PROCESS FROM NODE 44.00 TO NODE 45.00 IS CODE = 21

>>>>RATIONAL METHOD INITIAL SUBAREA ANALYSIS<<<<<
=====

ASSUMED INITIAL SUBAREA UNIFORM
DEVELOPMENT IS APARTMENT

$TC = K * [(LENGTH^{**3}) / (ELEVATION CHANGE)]^{**0.2}$
INITIAL SUBAREA FLOW-LENGTH(FEET) = 47.00
UPSTREAM ELEVATION(FEET) = 15.00
DOWNSTREAM ELEVATION(FEET) = 13.00
ELEVATION DIFFERENCE(FEET) = 2.00
 $TC = 0.323 * [(47.00^{**3}) / (2.00)]^{**0.2} = 2.830$
COMPUTED TIME OF CONCENTRATION INCREASED TO 5 MIN.
100 YEAR RAINFALL INTENSITY(INCH/HOUR) = 4.697
APARTMENT DEVELOPMENT RUNOFF COEFFICIENT = .8796
SOIL CLASSIFICATION IS "C"
SUBAREA RUNOFF(CFS) = 1.46
TOTAL AREA(ACRES) = 0.35 TOTAL RUNOFF(CFS) = 1.46

FLOW PROCESS FROM NODE 45.00 TO NODE 46.00 IS CODE = 41

>>>>COMPUTE PIPE-FLOW TRAVEL TIME THRU SUBAREA<<<<<
>>>>USING USER-SPECIFIED PIPESIZE (EXISTING ELEMENT)<<<<<
=====

REPRESENTATIVE SLOPE = 0.0100
FLOW LENGTH(FEET) = 32.65 MANNING'S N = 0.009
ASSUME FULL-FLOWING PIPELINE

PIPE-FLOW VELOCITY(FEET/SEC.) = 7.43
PIPE FLOW VELOCITY = (TOTAL FLOW)/(PIPE CROSS SECTION AREA)
GIVEN PIPE DIAMETER(INCH) = 6.00 NUMBER OF PIPES = 1
PIPE-FLOW(CFS) = 1.46
PIPE TRAVEL TIME(MIN.) = 0.07 Tc(MIN.) = 5.07
LONGEST FLOWPATH FROM NODE 44.00 TO NODE 46.00 = 79.65 FEET.

FLOW PROCESS FROM NODE 46.00 TO NODE 47.00 IS CODE = 41

>>>>COMPUTE PIPE-FLOW TRAVEL TIME THRU SUBAREA<<<<<
>>>>USING USER-SPECIFIED PIPESIZE (EXISTING ELEMENT)<<<<<

=====

REPRESENTATIVE SLOPE = 0.0100
FLOW LENGTH(FEET) = 231.00 MANNING'S N = 0.009
DEPTH OF FLOW IN 8.0 INCH PIPE IS 5.7 INCHES
PIPE-FLOW VELOCITY(FEET/SEC.) = 5.49
GIVEN PIPE DIAMETER(INCH) = 8.00 NUMBER OF PIPES = 1
PIPE-FLOW(CFS) = 1.46
PIPE TRAVEL TIME(MIN.) = 0.70 Tc(MIN.) = 5.77
LONGEST FLOWPATH FROM NODE 44.00 TO NODE 47.00 = 310.65 FEET.

FLOW PROCESS FROM NODE 47.00 TO NODE 47.00 IS CODE = 81

>>>>ADDITION OF SUBAREA TO MAINLINE PEAK FLOW<<<<<

=====

100 YEAR RAINFALL INTENSITY(INCH/HOUR) = 4.340
APARTMENT DEVELOPMENT RUNOFF COEFFICIENT = .8782
SOIL CLASSIFICATION IS "C"
SUBAREA AREA(ACRES) = 0.22 SUBAREA RUNOFF(CFS) = 0.85
TOTAL AREA(ACRES) = 0.6 TOTAL RUNOFF(CFS) = 2.31
TC(MIN.) = 5.77

FLOW PROCESS FROM NODE 47.00 TO NODE 48.00 IS CODE = 41

>>>>COMPUTE PIPE-FLOW TRAVEL TIME THRU SUBAREA<<<<<
>>>>USING USER-SPECIFIED PIPESIZE (EXISTING ELEMENT)<<<<<

=====

REPRESENTATIVE SLOPE = 0.0100
FLOW LENGTH(FEET) = 40.21 MANNING'S N = 0.009
ASSUME FULL-FLOWING PIPELINE
PIPE-FLOW VELOCITY(FEET/SEC.) = 6.61
PIPE FLOW VELOCITY = (TOTAL FLOW)/(PIPE CROSS SECTION AREA)
GIVEN PIPE DIAMETER(INCH) = 8.00 NUMBER OF PIPES = 1
PIPE-FLOW(CFS) = 2.31
PIPE TRAVEL TIME(MIN.) = 0.10 Tc(MIN.) = 5.88
LONGEST FLOWPATH FROM NODE 44.00 TO NODE 48.00 = 350.86 FEET.

FLOW PROCESS FROM NODE 48.00 TO NODE 48.00 IS CODE = 81

>>>>ADDITION OF SUBAREA TO MAINLINE PEAK FLOW<<<<<

100 YEAR RAINFALL INTENSITY(INCH/HOUR) = 4.298
APARTMENT DEVELOPMENT RUNOFF COEFFICIENT = .8780
SOIL CLASSIFICATION IS "C"
SUBAREA AREA(ACRES) = 0.29 SUBAREA RUNOFF(CFS) = 1.09
TOTAL AREA(ACRES) = 0.9 TOTAL RUNOFF(CFS) = 3.40
TC(MIN.) = 5.88

FLOW PROCESS FROM NODE 48.00 TO NODE 43.00 IS CODE = 41

>>>>COMPUTE PIPE-FLOW TRAVEL TIME THRU SUBAREA<<<<<
>>>>USING USER-SPECIFIED PIPESIZE (EXISTING ELEMENT)<<<<<

REPRESENTATIVE SLOPE = 0.0100
FLOW LENGTH(FEET) = 98.04 MANNING'S N = 0.009
ASSUME FULL-FLOWING PIPELINE
PIPE-FLOW VELOCITY(FEET/SEC.) = 9.73
PIPE FLOW VELOCITY = (TOTAL FLOW)/(PIPE CROSS SECTION AREA)
GIVEN PIPE DIAMETER(INCH) = 8.00 NUMBER OF PIPES = 1
PIPE-FLOW(CFS) = 3.40
PIPE TRAVEL TIME(MIN.) = 0.17 Tc(MIN.) = 6.04
LONGEST FLOWPATH FROM NODE 44.00 TO NODE 43.00 = 448.90 FEET.

FLOW PROCESS FROM NODE 43.00 TO NODE 43.00 IS CODE = 11

>>>>CONFLUENCE MEMORY BANK # 3 WITH THE MAIN-STREAM MEMORY<<<<<

** MAIN STREAM CONFLUENCE DATA **

STREAM RUNOFF Tc INTENSITY AREA
NUMBER (CFS) (MIN.) (INCH/HOUR) (ACRE)
1 3.40 6.04 4.232 0.86
LONGEST FLOWPATH FROM NODE 44.00 TO NODE 43.00 = 448.90 FEET.

** MEMORY BANK # 3 CONFLUENCE DATA **

STREAM RUNOFF Tc INTENSITY AREA
NUMBER (CFS) (MIN.) (INCH/HOUR) (ACRE)
1 2.64 5.40 4.502 0.66
2 2.64 5.56 4.430 0.66
3 2.60 6.09 4.215 0.66
LONGEST FLOWPATH FROM NODE 29.00 TO NODE 43.00 = 423.09 FEET.

** PEAK FLOW RATE TABLE **

STREAM RUNOFF Tc INTENSITY

NUMBER	(CFS)	(MIN.)	(INCH/HOUR)
1	5.67	5.40	4.502
2	5.76	5.56	4.430
3	5.97	6.04	4.232
4	5.98	6.09	4.215

COMPUTED CONFLUENCE ESTIMATES ARE AS FOLLOWS:

PEAK FLOW RATE(CFS) = 5.98 Tc(MIN.) = 6.09
TOTAL AREA(ACRES) = 1.5

FLOW PROCESS FROM NODE 43.00 TO NODE 43.00 IS CODE = 12

>>>>CLEAR MEMORY BANK # 3 <<<<<

FLOW PROCESS FROM NODE 43.00 TO NODE 49.00 IS CODE = 41

>>>>COMPUTE PIPE-FLOW TRAVEL TIME THRU SUBAREA<<<<<

>>>>USING USER-SPECIFIED PIPESIZE (EXISTING ELEMENT)<<<<<

REPRESENTATIVE SLOPE = 0.0100
FLOW LENGTH(FEET) = 33.92 MANNING'S N = 0.010
ASSUME FULL-FLOWING PIPELINE
PIPE-FLOW VELOCITY(FEET/SEC.) = 7.61
PIPE FLOW VELOCITY = (TOTAL FLOW)/(PIPE CROSS SECTION AREA)
GIVEN PIPE DIAMETER(INCH) = 12.00 NUMBER OF PIPES = 1
PIPE-FLOW(CFS) = 5.98
PIPE TRAVEL TIME(MIN.) = 0.07 Tc(MIN.) = 6.16
LONGEST FLOWPATH FROM NODE 44.00 TO NODE 49.00 = 482.82 FEET.

FLOW PROCESS FROM NODE 49.00 TO NODE 49.00 IS CODE = 10

>>>>MAIN-STREAM MEMORY COPIED ONTO MEMORY BANK # 2 <<<<<

FLOW PROCESS FROM NODE 49.00 TO NODE 49.00 IS CODE = 13

>>>>CLEAR THE MAIN-STREAM MEMORY<<<<<

FLOW PROCESS FROM NODE 50.00 TO NODE 51.00 IS CODE = 21

>>>>RATIONAL METHOD INITIAL SUBAREA ANALYSIS<<<<<

ASSUMED INITIAL SUBAREA UNIFORM

DEVELOPMENT IS APARTMENT

$TC = K * [(LENGTH^{**3}) / (ELEVATION CHANGE)]^{**0.2}$
 INITIAL SUBAREA FLOW-LENGTH(FEET) = 97.11
 UPSTREAM ELEVATION(FEET) = 878.85
 DOWNSTREAM ELEVATION(FEET) = 877.75
 ELEVATION DIFFERENCE(FEET) = 1.10
 $TC = 0.323 * [(97.11^{**3}) / (1.10)]^{**0.2} = 4.930$
 COMPUTED TIME OF CONCENTRATION INCREASED TO 5 MIN.
 100 YEAR RAINFALL INTENSITY(INCH/HOUR) = 4.697
 APARTMENT DEVELOPMENT RUNOFF COEFFICIENT = .8796
 SOIL CLASSIFICATION IS "C"
 SUBAREA RUNOFF(CFS) = 1.39
 TOTAL AREA(ACRES) = 0.34 TOTAL RUNOFF(CFS) = 1.39

 FLOW PROCESS FROM NODE 51.00 TO NODE 51.00 IS CODE = 11

 >>>>CONFLUENCE MEMORY BANK # 2 WITH THE MAIN-STREAM MEMORY<<<<<
 =====

** MAIN STREAM CONFLUENCE DATA **

STREAM NUMBER	RUNOFF (CFS)	Tc (MIN.)	INTENSITY (INCH/HOUR)	AREA (ACRE)
1	1.39	5.00	4.697	0.34

LONGEST FLOWPATH FROM NODE 50.00 TO NODE 51.00 = 97.11 FEET.

** MEMORY BANK # 2 CONFLUENCE DATA **

STREAM NUMBER	RUNOFF (CFS)	Tc (MIN.)	INTENSITY (INCH/HOUR)	AREA (ACRE)
1	5.67	5.48	4.467	1.52
2	5.76	5.64	4.397	1.52
3	5.97	6.12	4.204	1.52
4	5.98	6.16	4.187	1.52

LONGEST FLOWPATH FROM NODE 44.00 TO NODE 51.00 = 482.82 FEET.

** PEAK FLOW RATE TABLE **

STREAM NUMBER	RUNOFF (CFS)	Tc (MIN.)	INTENSITY (INCH/HOUR)
1	6.57	5.00	4.697
2	6.99	5.48	4.467
3	7.07	5.64	4.397
4	7.22	6.12	4.204
5	7.22	6.16	4.187

COMPUTED CONFLUENCE ESTIMATES ARE AS FOLLOWS:
 PEAK FLOW RATE(CFS) = 7.22 Tc(MIN.) = 6.16
 TOTAL AREA(ACRES) = 1.9

 FLOW PROCESS FROM NODE 51.00 TO NODE 51.00 IS CODE = 12

>>>>CLEAR MEMORY BANK # 2 <<<<<
=====

FLOW PROCESS FROM NODE 51.00 TO NODE 52.00 IS CODE = 41

>>>>COMPUTE PIPE-FLOW TRAVEL TIME THRU SUBAREA<<<<<
>>>>USING USER-SPECIFIED PIPESIZE (EXISTING ELEMENT)<<<<<
=====

REPRESENTATIVE SLOPE = 0.0100
FLOW LENGTH(FEET) = 51.05 MANNING'S N = 0.010
DEPTH OF FLOW IN 15.0 INCH PIPE IS 10.9 INCHES
PIPE-FLOW VELOCITY(FEET/SEC.) = 7.53
GIVEN PIPE DIAMETER(INCH) = 15.00 NUMBER OF PIPES = 1
PIPE-FLOW(CFS) = 7.22
PIPE TRAVEL TIME(MIN.) = 0.11 Tc(MIN.) = 6.28
LONGEST FLOWPATH FROM NODE 44.00 TO NODE 52.00 = 533.87 FEET.

FLOW PROCESS FROM NODE 52.00 TO NODE 52.00 IS CODE = 10

>>>>MAIN-STREAM MEMORY COPIED ONTO MEMORY BANK # 2 <<<<<
=====

FLOW PROCESS FROM NODE 52.00 TO NODE 52.00 IS CODE = 13

>>>>CLEAR THE MAIN-STREAM MEMORY<<<<<
=====

FLOW PROCESS FROM NODE 53.00 TO NODE 54.00 IS CODE = 21

>>>>RATIONAL METHOD INITIAL SUBAREA ANALYSIS<<<<<
=====

ASSUMED INITIAL SUBAREA UNIFORM
DEVELOPMENT IS APARTMENT
TC = $K * [(LENGTH^{**3}) / (ELEVATION CHANGE)]^{**0.2}$
INITIAL SUBAREA FLOW-LENGTH(FEET) = 96.84
UPSTREAM ELEVATION(FEET) = 878.85
DOWNSTREAM ELEVATION(FEET) = 877.60
ELEVATION DIFFERENCE(FEET) = 1.25
TC = $0.323 * [(96.84^{**3}) / (1.25)]^{**0.2} = 4.798$
COMPUTED TIME OF CONCENTRATION INCREASED TO 5 MIN.
100 YEAR RAINFALL INTENSITY(INCH/HOUR) = 4.697
APARTMENT DEVELOPMENT RUNOFF COEFFICIENT = .8796
SOIL CLASSIFICATION IS "C"
SUBAREA RUNOFF(CFS) = 1.28
TOTAL AREA(ACRES) = 0.31 TOTAL RUNOFF(CFS) = 1.28

FLOW PROCESS FROM NODE 54.00 TO NODE 54.00 IS CODE = 10

>>>>MAIN-STREAM MEMORY COPIED ONTO MEMORY BANK # 3 <<<<<

FLOW PROCESS FROM NODE 54.00 TO NODE 54.00 IS CODE = 13

>>>>CLEAR THE MAIN-STREAM MEMORY<<<<<

FLOW PROCESS FROM NODE 55.00 TO NODE 56.00 IS CODE = 21

>>>>RATIONAL METHOD INITIAL SUBAREA ANALYSIS<<<<<

ASSUMED INITIAL SUBAREA UNIFORM
DEVELOPMENT IS APARTMENT

TC = $K * [(LENGTH^{**3}) / (ELEVATION CHANGE)]^{** .2}$
INITIAL SUBAREA FLOW-LENGTH(FEET) = 217.19
UPSTREAM ELEVATION(FEET) = 881.21
DOWNSTREAM ELEVATION(FEET) = 878.03
ELEVATION DIFFERENCE(FEET) = 3.18
TC = $0.323 * [(217.19^{**3}) / (3.18)]^{** .2} = 6.463$
100 YEAR RAINFALL INTENSITY(INCH/HOUR) = 4.080
APARTMENT DEVELOPMENT RUNOFF COEFFICIENT = .8770
SOIL CLASSIFICATION IS "C"
SUBAREA RUNOFF(CFS) = 4.00
TOTAL AREA(ACRES) = 1.12 TOTAL RUNOFF(CFS) = 4.00

FLOW PROCESS FROM NODE 56.00 TO NODE 57.00 IS CODE = 41

>>>>COMPUTE PIPE-FLOW TRAVEL TIME THRU SUBAREA<<<<<
>>>>USING USER-SPECIFIED PIPESIZE (EXISTING ELEMENT)<<<<<

REPRESENTATIVE SLOPE = 0.0100
FLOW LENGTH(FEET) = 140.51 MANNING'S N = 0.009
ASSUME FULL-FLOWING PIPELINE
PIPE-FLOW VELOCITY(FEET/SEC.) = 11.45
PIPE FLOW VELOCITY = (TOTAL FLOW)/(PIPE CROSS SECTION AREA)
GIVEN PIPE DIAMETER(INCH) = 8.00 NUMBER OF PIPES = 1
PIPE-FLOW(CFS) = 4.00
PIPE TRAVEL TIME(MIN.) = 0.20 Tc(MIN.) = 6.67
LONGEST FLOWPATH FROM NODE 55.00 TO NODE 57.00 = 357.70 FEET.

FLOW PROCESS FROM NODE 57.00 TO NODE 57.00 IS CODE = 11

>>>>>CONFLUENCE MEMORY BANK # 3 WITH THE MAIN-STREAM MEMORY<<<<<<
=====

** MAIN STREAM CONFLUENCE DATA **

STREAM NUMBER	RUNOFF (CFS)	Tc (MIN.)	INTENSITY (INCH/HOUR)	AREA (ACRE)	
1	4.00	6.67	4.010	1.12	
LONGEST FLOWPATH FROM NODE					55.00 TO NODE 57.00 = 357.70 FEET.

** MEMORY BANK # 3 CONFLUENCE DATA **

STREAM NUMBER	RUNOFF (CFS)	Tc (MIN.)	INTENSITY (INCH/HOUR)	AREA (ACRE)	
1	1.28	5.00	4.697	0.31	
LONGEST FLOWPATH FROM NODE					53.00 TO NODE 57.00 = 96.84 FEET.

** PEAK FLOW RATE TABLE **

STREAM NUMBER	RUNOFF (CFS)	Tc (MIN.)	INTENSITY (INCH/HOUR)
1	4.28	5.00	4.697
2	5.09	6.67	4.010

COMPUTED CONFLUENCE ESTIMATES ARE AS FOLLOWS:

PEAK FLOW RATE(CFS) = 5.09 Tc(MIN.) = 6.67
TOTAL AREA(ACRES) = 1.4

FLOW PROCESS FROM NODE 57.00 TO NODE 57.00 IS CODE = 11

>>>>>CONFLUENCE MEMORY BANK # 2 WITH THE MAIN-STREAM MEMORY<<<<<<
=====

** MAIN STREAM CONFLUENCE DATA **

STREAM NUMBER	RUNOFF (CFS)	Tc (MIN.)	INTENSITY (INCH/HOUR)	AREA (ACRE)	
1	4.28	5.00	4.697	1.43	
2	5.09	6.67	4.010	1.43	
LONGEST FLOWPATH FROM NODE					55.00 TO NODE 57.00 = 357.70 FEET.

** MEMORY BANK # 2 CONFLUENCE DATA **

STREAM NUMBER	RUNOFF (CFS)	Tc (MIN.)	INTENSITY (INCH/HOUR)	AREA (ACRE)	
1	6.57	5.11	4.639	1.86	
2	6.99	5.59	4.417	1.86	
3	7.07	5.75	4.349	1.86	
4	7.22	6.23	4.162	1.86	
5	7.22	6.28	4.146	1.86	
LONGEST FLOWPATH FROM NODE					44.00 TO NODE 57.00 = 533.87 FEET.

** PEAK FLOW RATE TABLE **

STREAM NUMBER	RUNOFF (CFS)	Tc (MIN.)	INTENSITY (INCH/HOUR)
1	10.70	5.00	4.697
2	10.79	5.11	4.639
3	11.26	5.59	4.417
4	11.46	5.75	4.349
5	11.98	6.23	4.162
6	12.01	6.28	4.146
7	12.07	6.67	4.010

COMPUTED CONFLUENCE ESTIMATES ARE AS FOLLOWS:

PEAK FLOW RATE(CFS) = 12.07 Tc(MIN.) = 6.67
TOTAL AREA(ACRES) = 3.3

FLOW PROCESS FROM NODE 57.00 TO NODE 57.00 IS CODE = 12

>>>>CLEAR MEMORY BANK # 2 <<<<<

FLOW PROCESS FROM NODE 57.00 TO NODE 57.00 IS CODE = 12

>>>>CLEAR MEMORY BANK # 3 <<<<<

FLOW PROCESS FROM NODE 57.00 TO NODE 58.00 IS CODE = 41

>>>>COMPUTE PIPE-FLOW TRAVEL TIME THRU SUBAREA<<<<<
>>>>USING USER-SPECIFIED PIPESIZE (EXISTING ELEMENT)<<<<<

REPRESENTATIVE SLOPE = 0.0100
FLOW LENGTH(FEET) = 77.27 MANNING'S N = 0.010
DEPTH OF FLOW IN 18.0 INCH PIPE IS 13.4 INCHES
PIPE-FLOW VELOCITY(FEET/SEC.) = 8.53
GIVEN PIPE DIAMETER(INCH) = 18.00 NUMBER OF PIPES = 1
PIPE-FLOW(CFS) = 12.07
PIPE TRAVEL TIME(MIN.) = 0.15 Tc(MIN.) = 6.82
LONGEST FLOWPATH FROM NODE 44.00 TO NODE 58.00 = 611.14 FEET.

FLOW PROCESS FROM NODE 58.00 TO NODE 58.00 IS CODE = 11

>>>>CONFLUENCE MEMORY BANK # 1 WITH THE MAIN-STREAM MEMORY<<<<<

** MAIN STREAM CONFLUENCE DATA **

STREAM NUMBER	RUNOFF (CFS)	Tc (MIN.)	INTENSITY (INCH/HOUR)	AREA (ACRE)
---------------	--------------	-----------	-----------------------	-------------

1	10.70	5.15	4.619	3.29
2	10.79	5.27	4.564	3.29
3	11.26	5.74	4.352	3.29
4	11.46	5.90	4.287	3.29
5	11.98	6.38	4.108	3.29
6	12.01	6.43	4.092	3.29
7	12.07	6.82	3.961	3.29

LONGEST FLOWPATH FROM NODE 44.00 TO NODE 58.00 = 611.14 FEET.

** MEMORY BANK # 1 CONFLUENCE DATA **

STREAM NUMBER	RUNOFF (CFS)	Tc (MIN.)	INTENSITY (INCH/HOUR)	AREA (ACRE)
1	10.25	6.76	3.980	3.38
2	10.67	6.93	3.927	3.38
3	11.01	7.11	3.870	3.38
4	11.09	7.16	3.856	3.38
5	11.07	7.21	3.843	3.38
6	11.21	7.30	3.814	3.38
7	11.27	7.53	3.751	3.38
8	11.32	8.60	3.488	3.38
9	11.33	8.75	3.455	3.38
10	8.04	15.83	2.494	3.38

LONGEST FLOWPATH FROM NODE 9.00 TO NODE 58.00 = 1052.76 FEET.

** PEAK FLOW RATE TABLE **

STREAM NUMBER	RUNOFF (CFS)	Tc (MIN.)	INTENSITY (INCH/HOUR)
1	18.67	5.15	4.619
2	18.95	5.27	4.564
3	20.16	5.74	4.352
4	20.60	5.90	4.287
5	21.86	6.38	4.108
6	21.96	6.43	4.092
7	22.22	6.76	3.980
8	22.63	6.82	3.961
9	22.64	6.93	3.927
10	22.81	7.11	3.870
11	22.84	7.16	3.856
12	22.78	7.21	3.843
13	22.83	7.30	3.814
14	22.70	7.53	3.751
15	21.95	8.60	3.488
16	21.86	8.75	3.455
17	15.64	15.83	2.494

COMPUTED CONFLUENCE ESTIMATES ARE AS FOLLOWS:
 PEAK FLOW RATE(CFS) = 22.84 Tc(MIN.) = 7.16
 TOTAL AREA(ACRES) = 6.7

FLOW PROCESS FROM NODE 58.00 TO NODE 58.00 IS CODE = 12

>>>>CLEAR MEMORY BANK # 1 <<<<<

FLOW PROCESS FROM NODE 58.00 TO NODE 59.00 IS CODE = 41

>>>>COMPUTE PIPE-FLOW TRAVEL TIME THRU SUBAREA<<<<<
>>>>USING USER-SPECIFIED PIPESIZE (EXISTING ELEMENT)<<<<<

REPRESENTATIVE SLOPE = 0.0040
FLOW LENGTH(FEET) = 109.46 MANNING'S N = 0.013
DEPTH OF FLOW IN 36.0 INCH PIPE IS 19.2 INCHES
PIPE-FLOW VELOCITY(FEET/SEC.) = 5.97
GIVEN PIPE DIAMETER(INCH) = 36.00 NUMBER OF PIPES = 1
PIPE-FLOW(CFS) = 22.84
PIPE TRAVEL TIME(MIN.) = 0.31 Tc(MIN.) = 7.47
LONGEST FLOWPATH FROM NODE 9.00 TO NODE 59.00 = 1162.22 FEET.

END OF STUDY SUMMARY:

TOTAL AREA(ACRES) = 6.7 TC(MIN.) = 7.47
PEAK FLOW RATE(CFS) = 22.84

*** PEAK FLOW RATE TABLE ***

	Q(CFS)	Tc(MIN.)
1	18.67	5.48
2	18.95	5.59
3	20.16	6.06
4	20.60	6.22
5	21.86	6.69
6	21.96	6.74
7	22.22	7.07
8	22.63	7.12
9	22.64	7.23
10	22.81	7.42
11	22.84	7.47
12	22.78	7.51
13	22.83	7.61
14	22.70	7.84
15	21.95	8.91
16	21.86	9.06
17	15.64	16.17

END OF RATIONAL METHOD ANALYSIS



Catch Basin A1 - Grate Inlet

Project Description	
Solve For	Spread
Input Data	
Discharge	1.48 cfs
Gutter Width	5.13 ft
Gutter Cross Slope	0.051 ft/ft
Road Cross Slope	0.030 ft/ft
Grate Width	3.13 ft
Grate Length	4.0 ft
Local Depression	1.3 in
Local Depression Width	1.3 in
Grate Type	P-50 mm x 100 mm (P-1- 7/8"-4")
Clogging	50.0 %
Results	
Spread	5.2 ft
Depth	3.2 in
Gutter Depression	1.3 in
Total Depression	2.6 in
Open Grate Area	5.0 ft ²
Active Grate Weir Length	7.1 ft

Catch Basin A10 - Combination Inlet

Project Description	
Solve For	Spread
Input Data	
Discharge	0.20 cfs
Gutter Width	3.00 ft
Gutter Cross Slope	0.110 ft/ft
Road Cross Slope	0.018 ft/ft
Local Depression	2.0 in
Local Depression Width	2.0 in
Grate Width	2.80 ft
Grate Length	4.3 ft
Grate Type	P-50 mm (P-1 -7/8")
Clogging	50.0 %
Curb Opening Length	3.0 ft
Opening Height	0.5 ft
Curb Throat Type	Horizontal
Throat Incline Angle	90.00 degrees
Options	
Calculation Option	Use Both
Results	
Spread	0.6 ft
Depth	0.9 in
Gutter Depression	3.3 in
Total Depression	5.3 in
Open Grate Area	5.4 ft ²
Active Grate Weir Length	7.1 ft

Catch Basin A7 - Grate Inlet

Project Description	
Solve For	Spread
Input Data	
Discharge	4.41 cfs
Gutter Width	5.13 ft
Gutter Cross Slope	0.051 ft/ft
Road Cross Slope	0.031 ft/ft
Grate Width	3.13 ft
Grate Length	10.9 ft
Local Depression	1.3 in
Local Depression Width	1.3 in
Grate Type	P-50 mm x 100 mm (P-1- 7/8"-4")
Clogging	50.0 %
Results	
Spread	7.9 ft
Depth	4.2 in
Gutter Depression	1.2 in
Total Depression	2.5 in
Open Grate Area	13.6 ft ²
Active Grate Weir Length	14.0 ft

Catch Basin A9 - Grate Inlet

Project Description	
Solve For	Spread
Input Data	
Discharge	1.27 cfs
Gutter Width	5.13 ft
Gutter Cross Slope	0.051 ft/ft
Road Cross Slope	0.030 ft/ft
Grate Width	3.13 ft
Grate Length	7.4 ft
Local Depression	1.3 in
Local Depression Width	1.3 in
Grate Type	P-50 mm x 100 mm (P-1- 7/8"-4")
Clogging	50.0 %
Results	
Spread	4.5 ft
Depth	2.7 in
Gutter Depression	1.3 in
Total Depression	2.6 in
Open Grate Area	9.3 ft ²
Active Grate Weir Length	10.5 ft

Catch Basin B10 - Curb Opening Inlet

Project Description	
Solve For	Efficiency

Input Data	
Discharge	1.28 cfs
Slope	0.010 ft/ft
Gutter Width	1.50 ft
Gutter Cross Slope	0.220 ft/ft
Road Cross Slope	0.043 ft/ft
Roughness Coefficient	0.013
Curb Opening Length	7.0 ft
Local Depression	2.0 in
Local Depression Width	2.0 in

Results	
Efficiency	100.00 %
Intercepted Flow	1.28 cfs
Bypass Flow	0.00 cfs
Spread	2.2 ft
Depth	4.3 in
Flow Area	0.3 ft ²
Gutter Depression	3.2 in
Total Depression	5.2 in
Velocity	4.25 ft/s
Equivalent Cross Slope	0.329 ft/ft
Length Factor	1.588
Total Interception Length	4.4 ft

Catch Basin B3 - Curb Opening Inlet

Project Description	
Solve For	Efficiency

Input Data	
Discharge	0.22 cfs
Slope	0.010 ft/ft
Gutter Width	1.00 ft
Gutter Cross Slope	0.100 ft/ft
Road Cross Slope	0.021 ft/ft
Roughness Coefficient	0.013
Curb Opening Length	3.2 ft
Local Depression	1.0 in
Local Depression Width	1.0 in

Results	
Efficiency	100.00 %
Intercepted Flow	0.22 cfs
Bypass Flow	0.00 cfs
Spread	2.6 ft
Depth	1.6 in
Flow Area	0.1 ft ²
Gutter Depression	0.9 in
Total Depression	1.9 in
Velocity	1.98 ft/s
Equivalent Cross Slope	0.165 ft/ft
Length Factor	1.000
Total Interception Length	3.2 ft

Catch Basin B8 - Grate Inlet

Project Description	
Solve For	Spread
Input Data	
Discharge	1.39 cfs
Gutter Width	5.13 ft
Gutter Cross Slope	0.051 ft/ft
Road Cross Slope	0.043 ft/ft
Grate Width	3.13 ft
Grate Length	7.4 ft
Local Depression	1.3 in
Local Depression Width	1.3 in
Grate Type	P-50 mm x 100 mm (P-1- 7/8"-4")
Clogging	50.0 %
Results	
Spread	4.6 ft
Depth	2.8 in
Gutter Depression	0.5 in
Total Depression	1.8 in
Open Grate Area	9.3 ft ²
Active Grate Weir Length	10.5 ft

Catch Basin B9 - Grate Inlet

Project Description	
Solve For	Spread
Input Data	
Discharge	4.00 cfs
Gutter Width	5.13 ft
Gutter Cross Slope	0.051 ft/ft
Road Cross Slope	0.022 ft/ft
Grate Width	3.13 ft
Grate Length	10.9 ft
Local Depression	1.3 in
Local Depression Width	1.3 in
Grate Type	P-50 mm x 100 mm (P-1- 7/8"-4")
Clogging	50.0 %
Results	
Spread	8.5 ft
Depth	4.0 in
Gutter Depression	1.8 in
Total Depression	3.1 in
Open Grate Area	13.6 ft ²
Active Grate Weir Length	14.0 ft

<p>Catch Basin No. 1</p> <p>Drainage area no. B3</p> <p>Curb-opening CB in a sump</p> <p>Discharge, Q= 0.2 cfs (0.09 ac)</p> <p>Weir equation: $Q=CLh^{3/2}$</p> <p>Depth of flow in gutter, y= 0.03 ft</p> <p>Local depression, a= 0.08 ft</p> <p>$h=y+a=$ 0.11 ft</p> <p>Weir coefficient, C 3.0</p> <p>Length of opening: $L=Q/Ch^{3/2}$ 2.0 ft</p> <p>Use L= 2 ft</p> <p>Depth of ponding: $h=[Q/CL]^{2/3}$ 0.11 ft</p>	<p>Catch Basin No. 5</p> <p>Drainage area no. A9</p> <p>Grated inlet in a sump</p> <p>Discharge, Q= 1.3 cfs (0.32 ac)</p> <p>Weir equation: $Q=CLh^{3/2}$</p> <p>Depth of pond, h= 0.25 ft</p> <p>Weir coefficient, C 3.0</p> <p>Assume 50% clogging</p> <p>Perimeter required: $L=2Q/Ch^{3/2}$ 6.8 ft</p> <p>Use L= 7 ft</p> <p>Depth of ponding: $h=[2Q/CL]^{2/3}$ 0.24 ft</p>
<p>Catch Basin No. 2</p> <p>Drainage area no. B10</p> <p>Curb-opening CB in a sump</p> <p>Discharge, Q= 1.3 cfs (0.31 ac)</p> <p>Weir equation: $Q=CLh^{3/2}$</p> <p>Depth of flow in gutter, y= 0.03 ft</p> <p>Local depression, a= 0.17 ft</p> <p>$h=y+a=$ 0.20 ft</p> <p>Weir coefficient, C 3.0</p> <p>Length of opening: $L=Q/Ch^{3/2}$ 4.8 ft</p> <p>Use L= 7 ft</p> <p>Depth of ponding: $h=[Q/CL]^{2/3}$ 0.15 ft</p>	<p>Catch Basin No. 7</p> <p>Drainage area no. A7</p> <p>Grated inlet in a sump</p> <p>Discharge, Q= 4.4 cfs (1.32 ac)</p> <p>Weir equation: $Q=CLh^{3/2}$</p> <p>Depth of pond, h= 0.42 ft</p> <p>Weir coefficient, C 3.0</p> <p>Assume 50% clogging</p> <p>Perimeter required: $L=2Q/Ch^{3/2}$ 10.8 ft</p> <p>Use L= 11 ft</p> <p>Depth of ponding: $h=[2Q/CL]^{2/3}$ 0.42 ft</p>
<p>Catch Basin No. 3</p> <p>Drainage area no. B8</p> <p>Grated inlet in a sump</p> <p>Discharge, Q= 1.4 cfs (0.34 ac)</p> <p>Weir equation: $Q=CLh^{3/2}$</p> <p>Depth of pond, h= 0.25 ft</p> <p>Weir coefficient, C 3.0</p> <p>Assume 50% clogging</p> <p>Perimeter required: $L=2Q/Ch^{3/2}$ 7.4 ft</p> <p>Use L= 7 ft</p> <p>Depth of ponding: $h=[2Q/CL]^{2/3}$ 0.25 ft</p>	<p>Catch Basin No. 8</p> <p>Drainage area no. A1</p> <p>Grated inlet in a sump</p> <p>Discharge, Q= 1.5 cfs (0.37 ac)</p> <p>Weir equation: $Q=CLh^{3/2}$</p> <p>Depth of pond, h= 0.42 ft</p> <p>Weir coefficient, C 3.0</p> <p>Assume 50% clogging</p> <p>Perimeter required: $L=2Q/Ch^{3/2}$ 3.6 ft</p> <p>Use L= 4 ft</p> <p>Depth of ponding: $h=[2Q/CL]^{2/3}$ 0.39 ft</p>
<p>Catch Basin No. 4</p> <p>Drainage area no. B9</p> <p>Grated inlet in a sump</p> <p>Discharge, Q= 4.0 cfs (1.12 ac)</p> <p>Weir equation: $Q=CLh^{3/2}$</p> <p>Depth of pond, h= 0.42 ft</p> <p>Weir coefficient, C 3.0</p> <p>Assume 50% clogging</p> <p>Perimeter required: $L=2Q/Ch^{3/2}$ 9.8 ft</p> <p>Use L= 11 ft</p> <p>Depth of ponding: $h=[2Q/CL]^{2/3}$ 0.39 ft</p>	

Appendix 2.2

Post-Development Hydrology Map: Off-Site

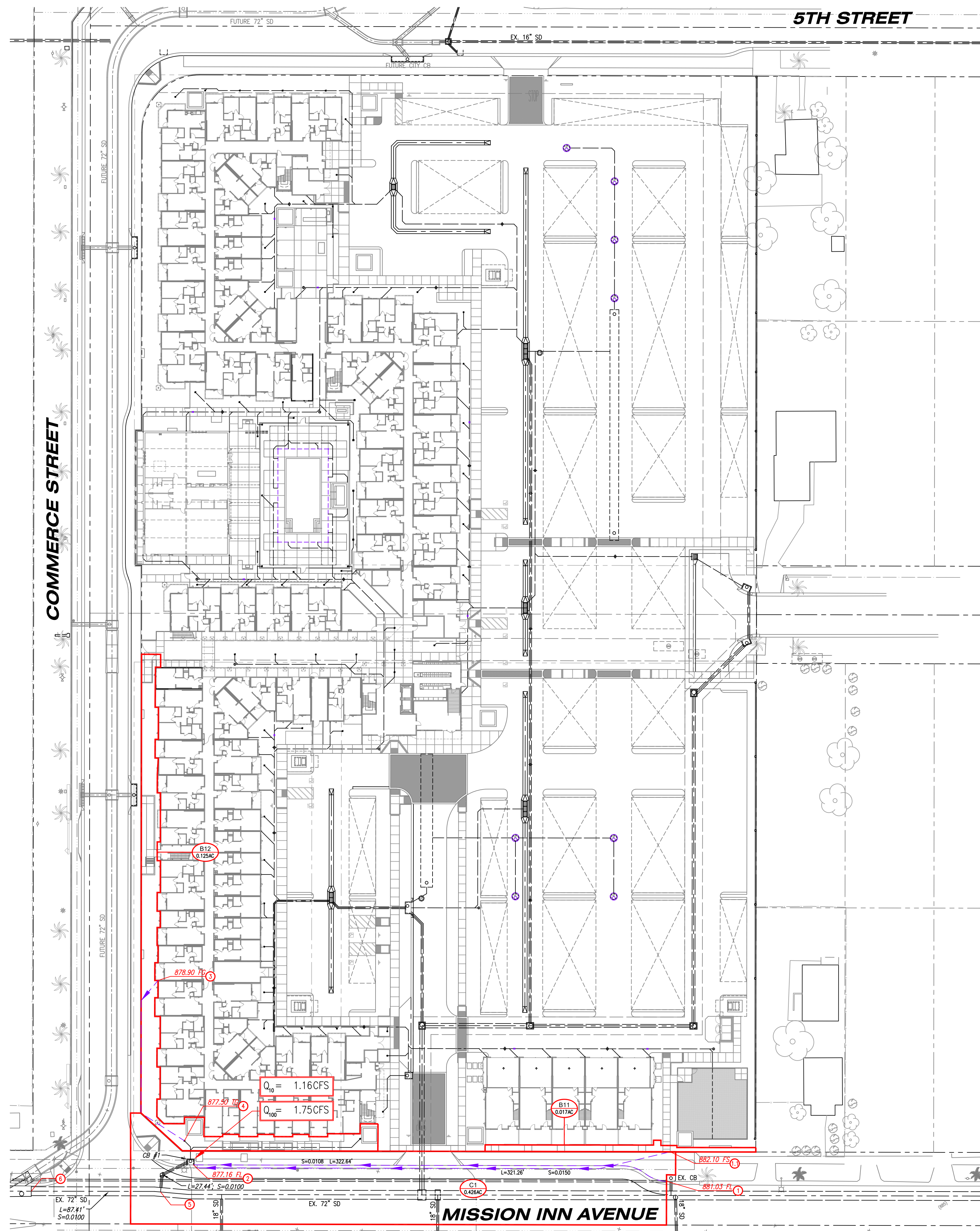

LEGEND

- ON-SITE SUBAREA BOUNDARY
- SURFACE FLOW PATH
S SURFACE FLOW PATH SLOPE
L SURFACE FLOW PATH LENGTH
- "X" SD
S PIPE FLOW PATH SLOPE
L PIPE FLOW PATH LENGTH
- XX
XX.XXAC OFF-SITE SUBAREA LABEL
- XXX.XX FL (XX) OFF-SITE ELEVATION NODES
- Q_{10} = XXXCFS 10-YEAR PEAK FLOW RATE
 T_c = X.XXMIN 10-YEAR TIME OF CONCENTRATION
- Q_{100} = XXXCFS 100-YEAR PEAK FLOW RATE
 T_c = X.XXMIN 100-YEAR TIME OF CONCENTRATION

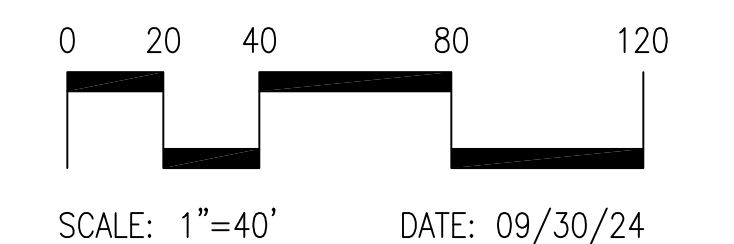
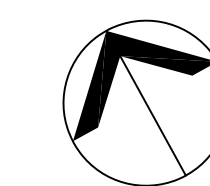

IRON LOFTS
IRON LOFTS, LLC

POST-DEVELOPMENT HYDROLOGY MAP - OFF-SITE AREA
RIVERSIDE, CALIFORNIA

KHR ASSOCIATES
CONSULTING ENGINEERS/SURVEYORS/PLANNERS
17530 Von Karman Ave. - Suite 200
Irvine, California 92614
Tel (949) 756-6440

Appendix 2.3

Post-Development Hydrology Calculations:

On-site plus Off-Site Street Runoff

RATIONAL METHOD HYDROLOGY COMPUTER PROGRAM BASED ON
RIVERSIDE COUNTY FLOOD CONTROL & WATER CONSERVATION DISTRICT
(RCFC&WCD) 1978 HYDROLOGY MANUAL
(c) Copyright 1982-2016 Advanced Engineering Software (aes)
(Rational Tabling Version 23.0)
Release Date: 07/01/2016 License ID 1681

Analysis prepared by:

KHR Associates
17530 Von Karman Avenue
Irvine, CA 92626

***** DESCRIPTION OF STUDY *****

* IRON LOFTS *
* POST-DEVELOPMENT HYDROLOGY - MISSION INN AVENUE STREET RUNOFF *
* 10-YEAR STORM EVENT *

FILE NAME: MISSION.DAT
TIME/DATE OF STUDY: 17:23 07/31/2024

USER SPECIFIED HYDROLOGY AND HYDRAULIC MODEL INFORMATION:

USER SPECIFIED STORM EVENT(YEAR) = 10.00
SPECIFIED MINIMUM PIPE SIZE(INCH) = 4.00
SPECIFIED PERCENT OF GRADIENTS(DECIMAL) TO USE FOR FRICTION SLOPE = 0.95
10-YEAR STORM 10-MINUTE INTENSITY(INCH/HOUR) = 2.140
10-YEAR STORM 60-MINUTE INTENSITY(INCH/HOUR) = 0.800
100-YEAR STORM 10-MINUTE INTENSITY(INCH/HOUR) = 3.210
100-YEAR STORM 60-MINUTE INTENSITY(INCH/HOUR) = 1.200
SLOPE OF 10-YEAR INTENSITY-DURATION CURVE = 0.5491525
SLOPE OF 100-YEAR INTENSITY-DURATION CURVE = 0.5491524

COMPUTED RAINFALL INTENSITY DATA:

STORM EVENT = 10.00 1-HOUR INTENSITY(INCH/HOUR) = 0.808
SLOPE OF INTENSITY DURATION CURVE = 0.5492

RCFC&WCD HYDROLOGY MANUAL "C"-VALUES USED FOR RATIONAL METHOD
NOTE: CONSIDER ALL CONFLUENCE STREAM COMBINATIONS

FOR ALL DOWNSTREAM ANALYSES

USER-DEFINED STREET-SECTIONS FOR COUPLED PIPEFLOW AND STREETFLOW MODEL

NO.	HALF-WIDTH (FT)	CROWN TO CROSSFALL (FT)	STREET-CROSSFALL IN-SIDE / OUT-SIDE / PARK-WAY	CURB HEIGHT (FT)	GUTTER WIDTH (FT)	GEOMETRIES LIP (FT)	MANNING HIKE (FT)	FACTOR (n)
1	30.0	20.0	0.018/0.018/0.020	0.67	2.00	0.0313	0.167	0.0150

GLOBAL STREET FLOW-DEPTH CONSTRAINTS:

1. Relative Flow-Depth = 0.00 FEET
as (Maximum Allowable Street Flow Depth) - (Top-of-Curb)
 2. (Depth)*(Velocity) Constraint = 6.0 (FT*FT/S)
- *SIZE PIPE WITH A FLOW CAPACITY GREATER THAN
OR EQUAL TO THE UPSTREAM TRIBUTARY PIPE.*

FLOW PROCESS FROM NODE 1.00 TO NODE 2.00 IS CODE = 21

>>>>RATIONAL METHOD INITIAL SUBAREA ANALYSIS<<<<<

=====

ASSUMED INITIAL SUBAREA UNIFORM
DEVELOPMENT IS COMMERCIAL

TC = K*[(LENGTH**3)/(ELEVATION CHANGE)]**.2
INITIAL SUBAREA FLOW-LENGTH(FEET) = 322.64
UPSTREAM ELEVATION(FEET) = 881.03
DOWNSTREAM ELEVATION(FEET) = 877.16
ELEVATION DIFFERENCE(FEET) = 3.87
TC = 0.303*[(322.64**3)/(3.87)]**.2 = 7.401
10 YEAR RAINFALL INTENSITY(INCH/HOUR) = 2.550
USER-SPECIFIED RUNOFF COEFFICIENT = .8829
SOIL CLASSIFICATION IS "C"
SUBAREA RUNOFF(CFS) = 0.96
TOTAL AREA(ACRES) = 0.43 TOTAL RUNOFF(CFS) = 0.96

+-----+
| SUBAREA C1 SHEETFLOWS TO CB #1 |
+-----+

FLOW PROCESS FROM NODE 1.10 TO NODE 2.00 IS CODE = 81

>>>>ADDITION OF SUBAREA TO MAINLINE PEAK FLOW<<<<<

=====

10 YEAR RAINFALL INTENSITY(INCH/HOUR) = 2.550
USER-SPECIFIED RUNOFF COEFFICIENT = .7288
SOIL CLASSIFICATION IS "C"
SUBAREA AREA(ACRES) = 0.02 SUBAREA RUNOFF(CFS) = 0.03
TOTAL AREA(ACRES) = 0.4 TOTAL RUNOFF(CFS) = 0.99
TC(MIN.) = 7.40

FLOW PROCESS FROM NODE 2.00 TO NODE 2.00 IS CODE = 10

>>>>MAIN-STREAM MEMORY COPIED ONTO MEMORY BANK # 1 <<<<<

FLOW PROCESS FROM NODE 2.00 TO NODE 2.00 IS CODE = 13

>>>>CLEAR THE MAIN-STREAM MEMORY<<<<<

FLOW PROCESS FROM NODE 3.00 TO NODE 4.00 IS CODE = 21

>>>>RATIONAL METHOD INITIAL SUBAREA ANALYSIS<<<<<

ASSUMED INITIAL SUBAREA UNIFORM
DEVELOPMENT IS: UNDEVELOPED WITH POOR COVER
TC = $K * [(LENGTH^{**3}) / (ELEVATION CHANGE)]^{**0.2}$
INITIAL SUBAREA FLOW-LENGTH(FEET) = 122.07
UPSTREAM ELEVATION(FEET) = 878.90
DOWNSTREAM ELEVATION(FEET) = 877.50
ELEVATION DIFFERENCE(FEET) = 1.40
TC = $0.533 * [(122.07^{**3}) / (1.40)]^{**0.2} = 8.895$
10 YEAR RAINFALL INTENSITY(INCH/HOUR) = 2.305
USER-SPECIFIED RUNOFF COEFFICIENT = .7143
SOIL CLASSIFICATION IS "C"
SUBAREA RUNOFF(CFS) = 0.21
TOTAL AREA(ACRES) = 0.12 TOTAL RUNOFF(CFS) = 0.21

FLOW PROCESS FROM NODE 4.00 TO NODE 2.00 IS CODE = 41

>>>>COMPUTE PIPE-FLOW TRAVEL TIME THRU SUBAREA<<<<<
>>>>USING USER-SPECIFIED PIPESIZE (EXISTING ELEMENT)<<<<<

REPRESENTATIVE SLOPE = 0.0100
FLOW LENGTH(FEET) = 14.77 MANNING'S N = 0.009
DEPTH OF FLOW IN 4.0 INCH PIPE IS 2.7 INCHES
PIPE-FLOW VELOCITY(FEET/SEC.) = 3.33
GIVEN PIPE DIAMETER(INCH) = 4.00 NUMBER OF PIPES = 1
PIPE-FLOW(CFS) = 0.21
PIPE TRAVEL TIME(MIN.) = 0.07 Tc(MIN.) = 8.97
LONGEST FLOWPATH FROM NODE 3.00 TO NODE 2.00 = 136.84 FEET.

FLOW PROCESS FROM NODE 2.00 TO NODE 2.00 IS CODE = 11

>>>>CONFLUENCE MEMORY BANK # 1 WITH THE MAIN-STREAM MEMORY<<<<<

** MAIN STREAM CONFLUENCE DATA **

STREAM NUMBER	RUNOFF (CFS)	Tc (MIN.)	INTENSITY (INCH/HOUR)	AREA (ACRE)
1	0.21	8.97	2.295	0.12

LONGEST FLOWPATH FROM NODE 3.00 TO NODE 2.00 = 136.84 FEET.

** MEMORY BANK # 1 CONFLUENCE DATA **

STREAM NUMBER	RUNOFF (CFS)	Tc (MIN.)	INTENSITY (INCH/HOUR)	AREA (ACRE)
1	0.99	7.40	2.550	0.44

LONGEST FLOWPATH FROM NODE 1.00 TO NODE 2.00 = 322.64 FEET.

** PEAK FLOW RATE TABLE **

STREAM NUMBER	RUNOFF (CFS)	Tc (MIN.)	INTENSITY (INCH/HOUR)
1	1.16	7.40	2.550
2	1.10	8.97	2.295

COMPUTED CONFLUENCE ESTIMATES ARE AS FOLLOWS:

PEAK FLOW RATE(CFS) = 1.16 Tc(MIN.) = 7.40
TOTAL AREA(ACRES) = 0.6

FLOW PROCESS FROM NODE 2.00 TO NODE 2.00 IS CODE = 12

>>>>CLEAR MEMORY BANK # 1 <<<<<

FLOW PROCESS FROM NODE 2.00 TO NODE 5.00 IS CODE = 41

>>>>COMPUTE PIPE-FLOW TRAVEL TIME THRU SUBAREA<<<<<
>>>>USING USER-SPECIFIED PIPESIZE (EXISTING ELEMENT)<<<<<

REPRESENTATIVE SLOPE = 0.0100
FLOW LENGTH(FEET) = 20.12 MANNING'S N = 0.013
DEPTH OF FLOW IN 18.0 INCH PIPE IS 4.1 INCHES
PIPE-FLOW VELOCITY(FEET/SEC.) = 3.83
GIVEN PIPE DIAMETER(INCH) = 18.00 NUMBER OF PIPES = 1
PIPE-FLOW(CFS) = 1.16
PIPE TRAVEL TIME(MIN.) = 0.09 Tc(MIN.) = 7.49
LONGEST FLOWPATH FROM NODE 1.00 TO NODE 5.00 = 342.76 FEET.

FLOW PROCESS FROM NODE 5.00 TO NODE 6.00 IS CODE = 41

>>>>COMPUTE PIPE-FLOW TRAVEL TIME THRU SUBAREA<<<<<
>>>>USING USER-SPECIFIED PIPESIZE (EXISTING ELEMENT)<<<<<

REPRESENTATIVE SLOPE = 0.0100
FLOW LENGTH(FEET) = 87.41 MANNING'S N = 0.013
DEPTH OF FLOW IN 72.0 INCH PIPE IS 2.8 INCHES
PIPE-FLOW VELOCITY(FEET/SEC.) = 3.19
GIVEN PIPE DIAMETER(INCH) = 72.00 NUMBER OF PIPES = 1
PIPE-FLOW(CFS) = 1.16

PIPE TRAVEL TIME(MIN.) = 0.46 Tc(MIN.) = 7.94
LONGEST FLOWPATH FROM NODE 1.00 TO NODE 6.00 = 430.17 FEET.

END OF STUDY SUMMARY:

TOTAL AREA(ACRES) = 0.6 TC(MIN.) = 7.94

PEAK FLOW RATE(CFS) = 1.16

*** PEAK FLOW RATE TABLE ***

	Q(CFS)	Tc(MIN.)
1	1.16	7.94
2	1.10	9.52

END OF RATIONAL METHOD ANALYSIS



RATIONAL METHOD HYDROLOGY COMPUTER PROGRAM BASED ON
RIVERSIDE COUNTY FLOOD CONTROL & WATER CONSERVATION DISTRICT
(RCFC&WCD) 1978 HYDROLOGY MANUAL
(c) Copyright 1982-2016 Advanced Engineering Software (aes)
(Rational Tabling Version 23.0)
Release Date: 07/01/2016 License ID 1681

Analysis prepared by:

KHR Associates
17530 Von Karman Avenue
Irvine, CA 92626

***** DESCRIPTION OF STUDY *****

- * IRON LOFTS *
 - * POST-DEVELOPMENT HYDROLOGY - MISSION INN AVENUE STREET RUNOFF *
 - * 100-YEAR STORM EVENT *
- *****

FILE NAME: MISSION.DAT
TIME/DATE OF STUDY: 17:24 07/31/2024

USER SPECIFIED HYDROLOGY AND HYDRAULIC MODEL INFORMATION:

USER SPECIFIED STORM EVENT(YEAR) = 100.00
SPECIFIED MINIMUM PIPE SIZE(INCH) = 4.00
SPECIFIED PERCENT OF GRADIENTS(DECIMAL) TO USE FOR FRICTION SLOPE = 0.95
10-YEAR STORM 10-MINUTE INTENSITY(INCH/HOUR) = 2.140
10-YEAR STORM 60-MINUTE INTENSITY(INCH/HOUR) = 0.800
100-YEAR STORM 10-MINUTE INTENSITY(INCH/HOUR) = 3.210
100-YEAR STORM 60-MINUTE INTENSITY(INCH/HOUR) = 1.200
SLOPE OF 10-YEAR INTENSITY-DURATION CURVE = 0.5491525
SLOPE OF 100-YEAR INTENSITY-DURATION CURVE = 0.5491524

COMPUTED RAINFALL INTENSITY DATA:

STORM EVENT = 100.00 1-HOUR INTENSITY(INCH/HOUR) = 1.200
SLOPE OF INTENSITY DURATION CURVE = 0.5492

RCFC&WCD HYDROLOGY MANUAL "C"-VALUES USED FOR RATIONAL METHOD
NOTE: CONSIDER ALL CONFLUENCE STREAM COMBINATIONS

FOR ALL DOWNSTREAM ANALYSES

USER-DEFINED STREET-SECTIONS FOR COUPLED PIPEFLOW AND STREETFLOW MODEL

NO.	HALF- CROWN TO		STREET-CROSSFALL:		CURB HEIGHT (FT)	GUTTER-GEOMETRIES:			MANNING FACTOR (n)
	WIDTH (FT)	CROSSFALL (FT)	IN- SIDE /	OUT- /PARK- SIDE/ WAY		WIDTH (FT)	LIP (FT)	HIKE (FT)	
1	30.0	20.0	0.018/0.018/0.020		0.67	2.00	0.0313	0.167	0.0150

GLOBAL STREET FLOW-DEPTH CONSTRAINTS:

1. Relative Flow-Depth = 0.00 FEET
as (Maximum Allowable Street Flow Depth) - (Top-of-Curb)
 2. (Depth)*(Velocity) Constraint = 6.0 (FT*FT/S)
- *SIZE PIPE WITH A FLOW CAPACITY GREATER THAN
OR EQUAL TO THE UPSTREAM TRIBUTARY PIPE.*

FLOW PROCESS FROM NODE 1.00 TO NODE 2.00 IS CODE = 21

>>>>RATIONAL METHOD INITIAL SUBAREA ANALYSIS<<<<<

=====

ASSUMED INITIAL SUBAREA UNIFORM
DEVELOPMENT IS COMMERCIAL

TC = K*[(LENGTH**3)/(ELEVATION CHANGE)]**.2
INITIAL SUBAREA FLOW-LENGTH(FEET) = 322.64
UPSTREAM ELEVATION(FEET) = 881.03
DOWNSTREAM ELEVATION(FEET) = 877.16
ELEVATION DIFFERENCE(FEET) = 3.87
TC = 0.303*[(322.64**3)/(3.87)]**.2 = 7.401
100 YEAR RAINFALL INTENSITY(INCH/HOUR) = 3.787
USER-SPECIFIED RUNOFF COEFFICIENT = .8877
SOIL CLASSIFICATION IS "C"
SUBAREA RUNOFF(CFS) = 1.43
TOTAL AREA(ACRES) = 0.43 TOTAL RUNOFF(CFS) = 1.43

+-----+
| SUBAREA C1 SHEETFLOWS TO CB #1 |
+-----+

FLOW PROCESS FROM NODE 1.10 TO NODE 2.00 IS CODE = 81

>>>>ADDITION OF SUBAREA TO MAINLINE PEAK FLOW<<<<<

=====

100 YEAR RAINFALL INTENSITY(INCH/HOUR) = 3.787
USER-SPECIFIED RUNOFF COEFFICIENT = .7771
SOIL CLASSIFICATION IS "C"
SUBAREA AREA(ACRES) = 0.02 SUBAREA RUNOFF(CFS) = 0.05
TOTAL AREA(ACRES) = 0.4 TOTAL RUNOFF(CFS) = 1.48
TC(MIN.) = 7.40

FLOW PROCESS FROM NODE 2.00 TO NODE 2.00 IS CODE = 10

>>>>MAIN-STREAM MEMORY COPIED ONTO MEMORY BANK # 1 <<<<<

FLOW PROCESS FROM NODE 2.00 TO NODE 2.00 IS CODE = 13

>>>>CLEAR THE MAIN-STREAM MEMORY<<<<<

FLOW PROCESS FROM NODE 3.00 TO NODE 4.00 IS CODE = 21

>>>>RATIONAL METHOD INITIAL SUBAREA ANALYSIS<<<<<

ASSUMED INITIAL SUBAREA UNIFORM
 DEVELOPMENT IS: UNDEVELOPED WITH POOR COVER
 $TC = K * [(LENGTH^{**3}) / (ELEVATION CHANGE)]^{**0.2}$
 INITIAL SUBAREA FLOW-LENGTH(FEET) = 122.07
 UPSTREAM ELEVATION(FEET) = 878.90
 DOWNSTREAM ELEVATION(FEET) = 877.50
 ELEVATION DIFFERENCE(FEET) = 1.40
 $TC = 0.533 * [(122.07^{**3}) / (1.40)]^{**0.2} = 8.895$
 100 YEAR RAINFALL INTENSITY(INCH/HOUR) = 3.423
 USER-SPECIFIED RUNOFF COEFFICIENT = .7660
 SOIL CLASSIFICATION IS "C"
 SUBAREA RUNOFF(CFS) = 0.33
 TOTAL AREA(ACRES) = 0.12 TOTAL RUNOFF(CFS) = 0.33

FLOW PROCESS FROM NODE 4.00 TO NODE 2.00 IS CODE = 41

>>>>COMPUTE PIPE-FLOW TRAVEL TIME THRU SUBAREA<<<<<
>>>>USING USER-SPECIFIED PIPESIZE (EXISTING ELEMENT)<<<<<

REPRESENTATIVE SLOPE = 0.0100
 FLOW LENGTH(FEET) = 14.77 MANNING'S N = 0.009
 ASSUME FULL-FLOWING PIPELINE
 PIPE-FLOW VELOCITY(FEET/SEC.) = 3.76
 PIPE FLOW VELOCITY = (TOTAL FLOW) / (PIPE CROSS SECTION AREA)
 GIVEN PIPE DIAMETER(INCH) = 4.00 NUMBER OF PIPES = 1
 PIPE-FLOW(CFS) = 0.33
 PIPE TRAVEL TIME(MIN.) = 0.07 Tc(MIN.) = 8.96
 LONGEST FLOWPATH FROM NODE 3.00 TO NODE 2.00 = 136.84 FEET.

FLOW PROCESS FROM NODE 2.00 TO NODE 2.00 IS CODE = 11

>>>>CONFLUENCE MEMORY BANK # 1 WITH THE MAIN-STREAM MEMORY<<<<<

** MAIN STREAM CONFLUENCE DATA **

STREAM NUMBER	RUNOFF (CFS)	Tc (MIN.)	INTENSITY (INCH/HOUR)	AREA (ACRE)
1	0.33	8.96	3.409	0.12

LONGEST FLOWPATH FROM NODE 3.00 TO NODE 2.00 = 136.84 FEET.

** MEMORY BANK # 1 CONFLUENCE DATA **

STREAM NUMBER	RUNOFF (CFS)	Tc (MIN.)	INTENSITY (INCH/HOUR)	AREA (ACRE)
1	1.48	7.40	3.787	0.44

LONGEST FLOWPATH FROM NODE 1.00 TO NODE 2.00 = 322.64 FEET.

** PEAK FLOW RATE TABLE **

STREAM NUMBER	RUNOFF (CFS)	Tc (MIN.)	INTENSITY (INCH/HOUR)
1	1.75	7.40	3.787
2	1.66	8.96	3.409

COMPUTED CONFLUENCE ESTIMATES ARE AS FOLLOWS:

PEAK FLOW RATE(CFS) = 1.75 Tc(MIN.) = 7.40
TOTAL AREA(ACRES) = 0.6

FLOW PROCESS FROM NODE 2.00 TO NODE 2.00 IS CODE = 12

>>>>CLEAR MEMORY BANK # 1 <<<<<

FLOW PROCESS FROM NODE 2.00 TO NODE 5.00 IS CODE = 41

>>>>COMPUTE PIPE-FLOW TRAVEL TIME THRU SUBAREA<<<<<
>>>>USING USER-SPECIFIED PIPESIZE (EXISTING ELEMENT)<<<<<

REPRESENTATIVE SLOPE = 0.0100
FLOW LENGTH(FEET) = 20.12 MANNING'S N = 0.013
DEPTH OF FLOW IN 18.0 INCH PIPE IS 5.0 INCHES
PIPE-FLOW VELOCITY(FEET/SEC.) = 4.33
GIVEN PIPE DIAMETER(INCH) = 18.00 NUMBER OF PIPES = 1
PIPE-FLOW(CFS) = 1.75
PIPE TRAVEL TIME(MIN.) = 0.08 Tc(MIN.) = 7.48
LONGEST FLOWPATH FROM NODE 1.00 TO NODE 5.00 = 342.76 FEET.

FLOW PROCESS FROM NODE 5.00 TO NODE 6.00 IS CODE = 41

>>>>COMPUTE PIPE-FLOW TRAVEL TIME THRU SUBAREA<<<<<
>>>>USING USER-SPECIFIED PIPESIZE (EXISTING ELEMENT)<<<<<

REPRESENTATIVE SLOPE = 0.0100
FLOW LENGTH(FEET) = 87.41 MANNING'S N = 0.013
DEPTH OF FLOW IN 72.0 INCH PIPE IS 3.4 INCHES
PIPE-FLOW VELOCITY(FEET/SEC.) = 3.62
GIVEN PIPE DIAMETER(INCH) = 72.00 NUMBER OF PIPES = 1

PIPE-FLOW(CFS) = 1.75
PIPE TRAVEL TIME(MIN.) = 0.40 Tc(MIN.) = 7.88
LONGEST FLOWPATH FROM NODE 1.00 TO NODE 6.00 = 430.17 FEET.

END OF STUDY SUMMARY:

TOTAL AREA(ACRES) = 0.6 TC(MIN.) = 7.88
PEAK FLOW RATE(CFS) = 1.75

*** PEAK FLOW RATE TABLE ***

	Q(CFS)	Tc(MIN.)
1	1.75	7.88
2	1.66	9.45

END OF RATIONAL METHOD ANALYSIS



Iron Lofts
Hydraulic Grade Line
Line B - 100-Year Storm Event

Table with columns: Station, Invert Elev, Depth (FT), Water Elev, Q (CFS), Vel (FPS), Vel Head, Energy Grd.El., Super Elev, Critical Depth, Flow Top Width, Height/Dia.-FT, Base Wt or I.D., ZL, No Wth Prs/Pip. Rows include station data from 103.000 to 111.650.

Iron Lofts
Hydraulic Grade Line
Line B - 100-Year Storm Event

Table with columns: Station, Invert Elev, Depth (FT), Water Elev, Q (CFS), Vel (FPS), Vel Head, Energy Grd.El., Super Elev, Critical Depth, Flow Top Width, Height/Dia.-FT, Base Wt or I.D., ZL, No Wth Prs/Pip. Rows include data for stations 114.115, 118.004, 120.575, 122.466, 123.921, 125.091, 126.053, 126.856, and 127.526.

Iron Lofts
Hydraulic Grade Line
Line B - 100-Year Storm Event

Table with columns: Station, Invert Elev, Depth (FT), Water Elev, Q (CFS), Vel (FPS), Vel Head, Energy Grd.El., Super Elev, Critical Depth, Flow Top Width, Height/Dia.-FT, Base Wt or I.D., ZL, No Wth Prs/Pip. Rows include station numbers like 128.097, 128.578, 128.991, 129.347, 129.654, 129.903, 130.123, 130.304, 130.448 and various hydraulic parameters.

Iron Lofts
 Hydraulic Grade Line
 Line B - 100-Year Storm Event

```

*****
Station | Invert | Depth | Water | Q | Vel | Vel | Energy | Super | Critical | Flow Top | Height/ | Base Wt | | No Wth
      | Elev   | (FT)  | Elev   | (CFS) | (FPS) | Head | Grd.El. | Elev  | Depth   | Width   | Dia.-FT | or I.D. | ZL | Prs/Pip
      | -|-   | -|-   | -|-   | -|-   | -|-   | -|-   | -|-   | -|-   | -|-   | -|-   | -|-   | -|- | -|
L/Elem | Ch Slope | | | | | | | | | | | | | | | |
***** | ***** | ***** | ***** | ***** | ***** | ***** | ***** | ***** | ***** | ***** | ***** | ***** | ***** | *****
130.568 | 873.135 | .418 | 873.553 | 1.75 | 4.35 | .29 | 873.85 | .00 | .50 | 1.35 | 1.500 | .000 | .00 | 1 .0
      | -|-   | -|-   | -|-   | -|-   | -|-   | -|-   | -|-   | -|-   | -|-   | -|-   | -|-   | -|- | -|
      | .098 | .1382 | | | | | | | | | | | | | | | |
130.666 | 873.149 | .432 | 873.581 | 1.75 | 4.15 | .27 | 873.85 | .00 | .50 | 1.36 | 1.500 | .000 | .00 | 1 .0
      | -|-   | -|-   | -|-   | -|-   | -|-   | -|-   | -|-   | -|-   | -|-   | -|-   | -|-   | -|- | -|
      | .071 | .1382 | | | | | | | | | | | | | | | |
130.737 | 873.159 | .447 | 873.606 | 1.75 | 3.95 | .24 | 873.85 | .00 | .50 | 1.37 | 1.500 | .000 | .00 | 1 .0
      | -|-   | -|-   | -|-   | -|-   | -|-   | -|-   | -|-   | -|-   | -|-   | -|-   | -|-   | -|- | -|
      | .046 | .1382 | | | | | | | | | | | | | | | |
130.784 | 873.165 | .463 | 873.628 | 1.75 | 3.77 | .22 | 873.85 | .00 | .50 | 1.39 | 1.500 | .000 | .00 | 1 .0
      | -|-   | -|-   | -|-   | -|-   | -|-   | -|-   | -|-   | -|-   | -|-   | -|-   | -|-   | -|- | -|
      | .031 | .1382 | | | | | | | | | | | | | | | |
130.814 | 873.169 | .479 | 873.648 | 1.75 | 3.59 | .20 | 873.85 | .00 | .50 | 1.40 | 1.500 | .000 | .00 | 1 .0
      | -|-   | -|-   | -|-   | -|-   | -|-   | -|-   | -|-   | -|-   | -|-   | -|-   | -|-   | -|- | -|
      | .006 | .1382 | | | | | | | | | | | | | | | |
130.820 | 873.170 | .498 | 873.668 | 1.75 | 3.42 | .18 | 873.85 | .00 | .50 | 1.41 | 1.500 | .000 | .00 | 1 .0
      | -|-   | -|-   | -|-   | -|-   | -|-   | -|-   | -|-   | -|-   | -|-   | -|-   | -|-   | -|- | -|
      | | | | | | | | | | | | | | | |
    
```

CB1 - Curb Opening Inlet Q10

Project Description	
Solve For	Spread
Input Data	
Discharge	1.16 cfs
Gutter Width	2.00 ft
Gutter Cross Slope	0.022 ft/ft
Road Cross Slope	0.020 ft/ft
Curb Opening Length	4.0 ft
Opening Height	0.7 ft
Curb Throat Type	Horizontal
Local Depression	2.0 in
Local Depression Width	2.0 in
Throat Incline Angle	90.00 degrees
Results	
Spread	8.2 ft
Depth	2.0 in
Gutter Depression	0.0 in
Total Depression	2.0 in

CB1 - Curb Opening Inlet Q100

Project Description	
Solve For	Spread

Input Data	
Discharge	1.75 cfs
Gutter Width	2.00 ft
Gutter Cross Slope	0.022 ft/ft
Road Cross Slope	0.020 ft/ft
Curb Opening Length	4.0 ft
Opening Height	0.7 ft
Curb Throat Type	Horizontal
Local Depression	2.0 in
Local Depression Width	2.0 in
Throat Incline Angle	90.00 degrees

Results	
Spread	10.8 ft
Depth	2.6 in
Gutter Depression	0.0 in
Total Depression	2.0 in

Pipe Capacity: 18SD @0.192 - Q10

Project Description	
Friction Method	Manning
	Formula
Solve For	Normal Depth
Input Data	
Roughness Coefficient	0.013
Channel Slope	0.192 ft/ft
Diameter	18.0 in
Discharge	1.16 cfs
Results	
Normal Depth	2.0 in
Flow Area	0.1 ft ²
Wetted Perimeter	1.0 ft
Hydraulic Radius	1.2 in
Top Width	0.94 ft
Critical Depth	4.8 in
Percent Full	10.9 %
Critical Slope	0.005 ft/ft
Velocity	11.04 ft/s
Velocity Head	1.90 ft
Specific Energy	2.06 ft
Froude Number	5.815
Maximum Discharge	49.47 cfs
Discharge Full	45.99 cfs
Slope Full	0.000 ft/ft
Flow Type	Supercritical
GVF Input Data	
Downstream Depth	0.0 in
Length	0.0 ft
Number Of Steps	0
GVF Output Data	
Upstream Depth	0.0 in
Profile Description	N/A
Profile Headloss	0.00 ft
Average End Depth Over Rise	0.0 %
Normal Depth Over Rise	10.9 %
Downstream Velocity	Infinity ft/s
Upstream Velocity	Infinity ft/s
Normal Depth	2.0 in
Critical Depth	4.8 in
Channel Slope	0.192 ft/ft
Critical Slope	0.005 ft/ft

Pipe Capacity: 18SD @0.192 - Q100

Project Description	
Friction Method	Manning Formula
Solve For	Normal Depth
Input Data	
Roughness Coefficient	0.013
Channel Slope	0.192 ft/ft
Diameter	18.0 in
Discharge	1.75 cfs
Results	
Normal Depth	2.4 in
Flow Area	0.1 ft ²
Wetted Perimeter	1.1 ft
Hydraulic Radius	1.5 in
Top Width	1.02 ft
Critical Depth	6.0 in
Percent Full	13.3 %
Critical Slope	0.005 ft/ft
Velocity	12.51 ft/s
Velocity Head	2.43 ft
Specific Energy	2.63 ft
Froude Number	5.952
Maximum Discharge	49.47 cfs
Discharge Full	45.99 cfs
Slope Full	0.000 ft/ft
Flow Type	Supercritical
GVF Input Data	
Downstream Depth	0.0 in
Length	0.0 ft
Number Of Steps	0
GVF Output Data	
Upstream Depth	0.0 in
Profile Description	N/A
Profile Headloss	0.00 ft
Average End Depth Over Rise	0.0 %
Normal Depth Over Rise	13.3 %
Downstream Velocity	Infinity ft/s
Upstream Velocity	Infinity ft/s
Normal Depth	2.4 in
Critical Depth	6.0 in
Channel Slope	0.192 ft/ft
Critical Slope	0.005 ft/ft

Pipe Capacity: 18SD @0.010 - Q100

Project Description	
Friction Method	Manning Formula
Solve For	Normal Depth
Input Data	
Roughness Coefficient	0.013
Channel Slope	0.010 ft/ft
Diameter	18.0 in
Discharge	1.75 cfs
Results	
Normal Depth	5.0 in
Flow Area	0.4 ft ²
Wetted Perimeter	1.7 ft
Hydraulic Radius	2.9 in
Top Width	1.34 ft
Critical Depth	6.0 in
Percent Full	27.6 %
Critical Slope	0.005 ft/ft
Velocity	4.41 ft/s
Velocity Head	0.30 ft
Specific Energy	0.72 ft
Froude Number	1.427
Maximum Discharge	11.30 cfs
Discharge Full	10.50 cfs
Slope Full	0.000 ft/ft
Flow Type	Supercritical
GVF Input Data	
Downstream Depth	0.0 in
Length	0.0 ft
Number Of Steps	0
GVF Output Data	
Upstream Depth	0.0 in
Profile Description	N/A
Profile Headloss	0.00 ft
Average End Depth Over Rise	0.0 %
Normal Depth Over Rise	27.6 %
Downstream Velocity	Infinity ft/s
Upstream Velocity	Infinity ft/s
Normal Depth	5.0 in
Critical Depth	6.0 in
Channel Slope	0.010 ft/ft
Critical Slope	0.005 ft/ft

Pipe Capacity: 18SD @0.008 - Q100

Project Description	
Friction Method	Manning Formula
Solve For	Normal Depth
Input Data	
Roughness Coefficient	0.013
Channel Slope	0.008 ft/ft
Diameter	18.0 in
Discharge	1.75 cfs
Results	
Normal Depth	5.4 in
Flow Area	0.4 ft ²
Wetted Perimeter	1.7 ft
Hydraulic Radius	3.1 in
Top Width	1.37 ft
Critical Depth	6.0 in
Percent Full	29.7 %
Critical Slope	0.005 ft/ft
Velocity	3.98 ft/s
Velocity Head	0.25 ft
Specific Energy	0.69 ft
Froude Number	1.237
Maximum Discharge	9.79 cfs
Discharge Full	9.10 cfs
Slope Full	0.000 ft/ft
Flow Type	Supercritical
GVF Input Data	
Downstream Depth	0.0 in
Length	0.0 ft
Number Of Steps	0
GVF Output Data	
Upstream Depth	0.0 in
Profile Description	N/A
Profile Headloss	0.00 ft
Average End Depth Over Rise	0.0 %
Normal Depth Over Rise	29.7 %
Downstream Velocity	Infinity ft/s
Upstream Velocity	Infinity ft/s
Normal Depth	5.4 in
Critical Depth	6.0 in
Channel Slope	0.008 ft/ft
Critical Slope	0.005 ft/ft

Pipe Capacity: 18SD @0.005 - Q100

Project Description	
Friction Method	Manning Formula
Solve For	Normal Depth
Input Data	
Roughness Coefficient	0.013
Channel Slope	0.005 ft/ft
Diameter	18.0 in
Discharge	1.75 cfs
Results	
Normal Depth	5.9 in
Flow Area	0.5 ft ²
Wetted Perimeter	1.8 ft
Hydraulic Radius	3.3 in
Top Width	1.41 ft
Critical Depth	6.0 in
Percent Full	33.0 %
Critical Slope	0.005 ft/ft
Velocity	3.44 ft/s
Velocity Head	0.18 ft
Specific Energy	0.68 ft
Froude Number	1.009
Maximum Discharge	7.99 cfs
Discharge Full	7.43 cfs
Slope Full	0.000 ft/ft
Flow Type	Supercritical
GVF Input Data	
Downstream Depth	0.0 in
Length	0.0 ft
Number Of Steps	0
GVF Output Data	
Upstream Depth	0.0 in
Profile Description	N/A
Profile Headloss	0.00 ft
Average End Depth Over Rise	0.0 %
Normal Depth Over Rise	33.0 %
Downstream Velocity	Infinity ft/s
Upstream Velocity	Infinity ft/s
Normal Depth	5.9 in
Critical Depth	6.0 in
Channel Slope	0.005 ft/ft
Critical Slope	0.005 ft/ft