

**SYMBOLS**

- ▲ FIRE HYDRANT
- STREET LIGHT
- ⊕ TRAFFIC SIGNAL
- ⊕ TRAFFIC SIGNAL ARM & POLE
- ⊕ ELECTRIC METER
- ⊕ LIGHT STANDARD
- ⊕ PARKING LIGHT
- ⊕ UTILITY POLE
- ⊕ GUY WIRE & ANCHOR
- ⊕ WATER METER
- ⊕ GAS METER
- ⊕ WATER VALVE
- ⊕ GAS VALVE
- ⊕ PULL BOX
- ⊕ GRATE INLET
- ⊕ SIGN
- ⊕ SEWER MANHOLE
- ⊕ STORM DRAIN MANHOLE
- ⊕ TELEPHONE MANHOLE
- ⊕ MANHOLE
- ⊕ SEWER CLEANOUT
- ⊕ HANDICAP PARKING STALL
- ⊕ LANDSCAPED AREA
- ⊕ PLOTABLE EASEMENT ITEM  
No. PER TITLE REPORT
- EXIST. CONTOUR
- ⊕ TREES

**LINE TYPE LEGEND**

- CATV = CABLE TV LINE
- E = ELECTRICAL LINE
- G = GAS LINE
- GB-GB = GRADE BREAK LINE
- R = RIDGE LINE
- S = SEWER LINE
- SD = STORM DRAIN LINE
- T = TELEPHONE LINE
- W = WATER LINE
- SS = SANITARY LINE
- OH = OVERHEAD UTILITY LINE

**ABBREVIATIONS**

- AB = AGGREGATE BASE
- AC = ASPHALT CONCRETE
- CF = CURB FACE
- CL = CENTERLINE
- CO = CLEANOUT
- DG = DECOMPOSED GRANITE
- FD = FOUND
- FF = FINISHED FLOOR
- FG = FINISHED GRADE
- FH = FIRE HYDRANT
- FL = FLOW LINE
- FS = FINISHED SURFACE
- GB = GRADE BREAK
- GM = GAS METER
- GR = TOP OF GRATE
- GV = GAS VALVE
- HT = HEIGHT
- IP = IRON PIPE
- LS = LIGHT STANDARD
- LT = LEAD & TAG
- MH = MANHOLE
- NG = NATURAL GROUND
- N&T = NAIL & TAG
- PA = PLANTING AREA
- PB = PULL BOX
- PCC = CONCRETE
- PL = PROPERTY LINE
- SMH = SEWER MANHOLE
- SPK = SPIKE
- SW = SIDEWALK
- TC = TOP OF CURB
- W = WASHER
- WM = WATER METER
- WV = WATER VALVE
- N. = NORTH
- S. = SOUTH
- E. = EAST
- W. = WEST
- NLY = NORTHERLY
- SLY = SOUTHERLY
- Ely = EASTERLY
- Wly = WESTERLY
- N/O = NORTH OF
- S/O = SOUTH OF
- E/O = EAST OF
- W/O = WEST OF
- ⊕ = PROPERTY LINE
- ⊕ = CENTERLINE
- ⊕ = RIGHT OF WAY
- Δ = DELTA
- R = RADIUS
- L = LENGTH
- T = TANGENT
- (RAD) = RADIAL BEARING
- (427.00) TC = EXISTING ELEVATION

**HATCH LEGEND**

- ▲ CONCRETE OR MISC. HARDSCAPE
- ▨ ASPHALT CONCRETE
- ▨ NEW STRUCTURE
- ▨ BIO-RETENTION

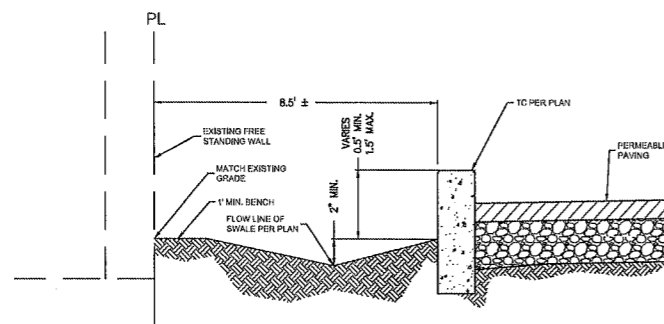

TYPICAL SECTION AT NW' LY PL

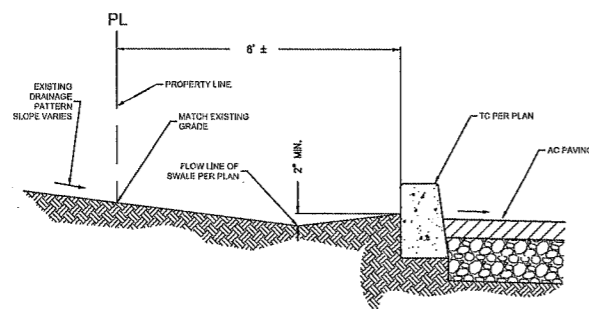

TYPICAL SECTION AT SW' LY PL

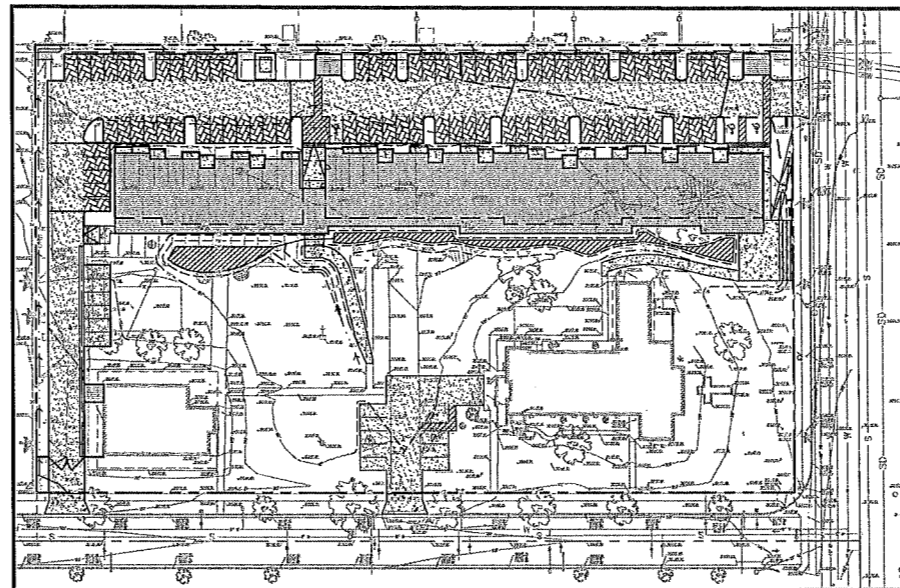

**OVERALL SITE**

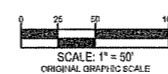

**PHASE 1  
CONCEPTUAL GRADING AND  
PRELIMINARY UTILITY PLAN  
ST. MICHAEL'S - RIVERSIDE  
4070 JACKSON ST.  
RIVERSIDE, CA 92503**

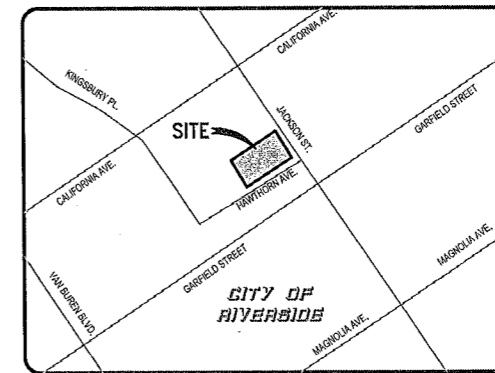

VICINITY MAP  
NOT TO SCALE

**DEVELOPER:**

COMMUNITY DEVELOPMENT PARTNERS  
3410 VIA OPORTO, SUITE 301  
NEWPORT BEACH, CA 92663  
949-467-1344

**CIVIL:**

WARE MALCOMB  
10 EDELMAN  
IRVINE, CA 92618  
ATTN: LUCAS CORSBIE  
949-660-9128 EXT: 1159

**ARCHITECT**

ESCHER GUNWARDENA ARCHITECTURE  
815 SILVER LAKE BLVD  
LOS ANGELES, CA  
ATTN: DANIEL CARLSON  
323-659-6100

**GEOTECHNICAL ENGINEER:**

ERECO INC.  
6 MORGAN, SUITE 182  
IRVINE, CA 92618  
PRELIM REPORT / PROJECT # 18031.000.000  
929-628-3470

**LAND SURVEYOR:**

EPS GROUP, INC.  
2929 DOW AVENUE, SUITE 314  
TUSTIN, CA 92780  
ATTN: NICK OWEN  
714-389-0009

**GENERAL CONTRACTOR:**

TBD

**EARTHWORK ESTIMATE**

	CUT (CY)	FILL (CY)
GENERAL	200	2,700
NET		2,470

NOTE: THE ESTIMATED QUANTITIES HEREON ARE ONLY FOR THE PURPOSE OF OBTAINING THE NECESSARY PERMITS. WARE MALCOMB DOES NOT GUARANTEE THE ACCURACY OF THE ESTIMATED QUANTITIES. THE CONTRACTOR SHALL PERFORM HIS OWN QUANTITY TAKEOFF BEFORE SUBMITTING A BID FOR ANY PORTION OF THE IMPROVEMENTS COVERED BY THESE PLANS.

**SHEET INDEX**

SHEET	TITLE
SHEET C-1.1	TITLE SHEET AND SECTIONS
SHEET C-2.0	CONCEPTUAL GRADING AND PRELIMINARY UTILITY PLAN
SHEET C-3.0	SITE SECTIONS
SHEET C-3.1	SITE SECTIONS
SHEET C-3.2	SITE SECTIONS
SHEET C-4.0	BMP SECTIONS AND DETAILS

**WARE MALCOMB**  
LEADING DESIGN FOR COMMERCIAL REAL ESTATE

10 Edelman  
Irvine, CA 92618  
P 949.660.9128  
waremalcomb.com

REGISTERED PROFESSIONAL ENGINEER  
**LUCAS A. CORSBIE**  
No. 72989  
CIVIL  
STATE OF CALIFORNIA  
Dec 18, 2019

FOR AND ON BEHALF  
OF WARE MALCOMB

**ST. MICHAEL'S - RIVERSIDE**  
4070 JACKSON ST.  
RIVERSIDE, CA 92503  
PHASE 1

CONCEPTUAL GRADING AND UTILITY PLAN

NO.	DATE	REMARKS

JOB NO.:	IRV18-4039
PA / PM:	LC
DRAWN BY:	BS
DATE:	07-01-19

SHEET  
**C-1.0**  
Sheet 1 of 6

CAUTION: IF THIS SHEET IS NOT 24"x36" IT IS A REDUCED PRINT

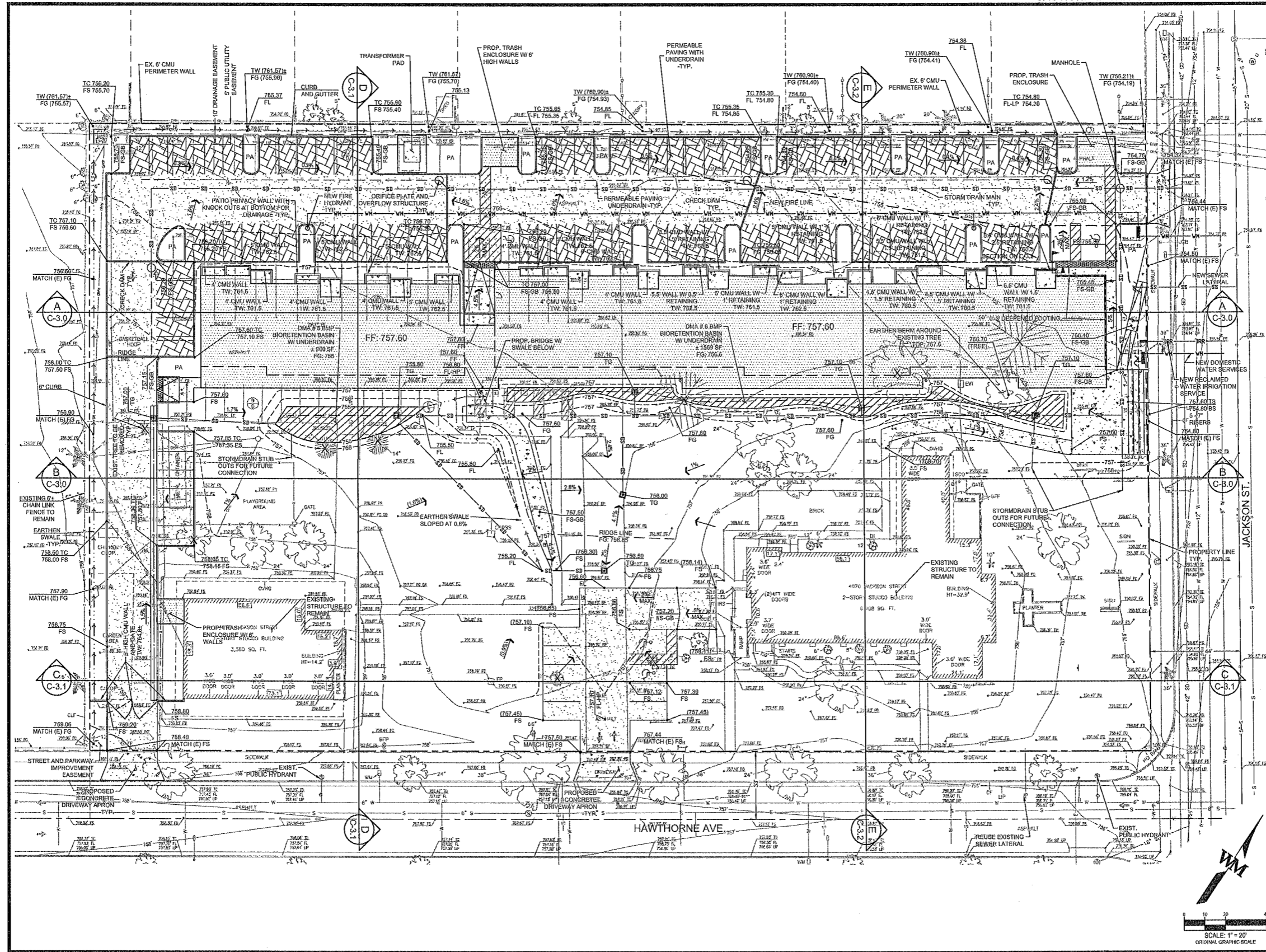

**WARE MALCOMB**  
LEADING DESIGN FOR COMMERCIAL REAL ESTATE

10 edelman  
in/ve, ca 92518  
p 949.650.9128  
waremalcomb.com



FOR AND ON BEHALF OF WARE MALCOMB

**ST. MICHAEL'S - RIVERSIDE**  
4070 JACKSON ST.  
RIVERSIDE, CA 92503  
PHASE 1

NO.	DATE	REMARKS

JOB NO.: IRV18-4039  
PA / PM: LC  
DRAWN BY: BS  
DATE: 07-01-19

SHEET  
**C-2.0**  
Sheet 2 of 6

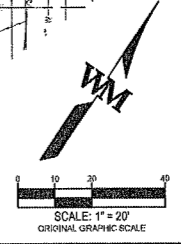

P19-0507 (CUP) & P19-0508 (DR), Exhibit 7 - Project Plans

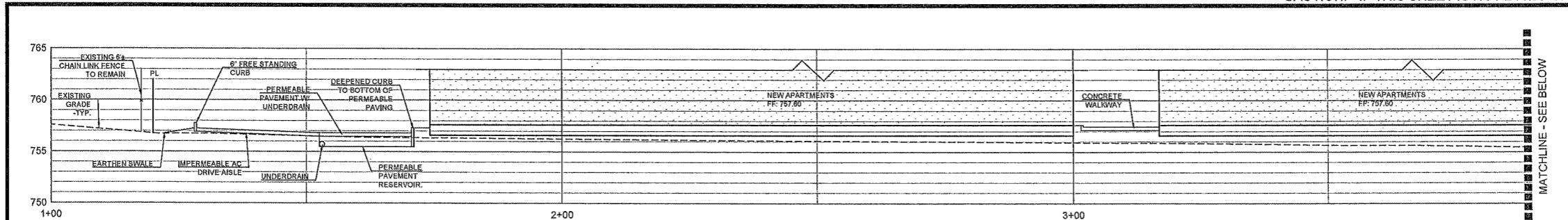

SECTION A-A  
(SCALE: 1"=10 HORIZ. 1"=5' VERT.)

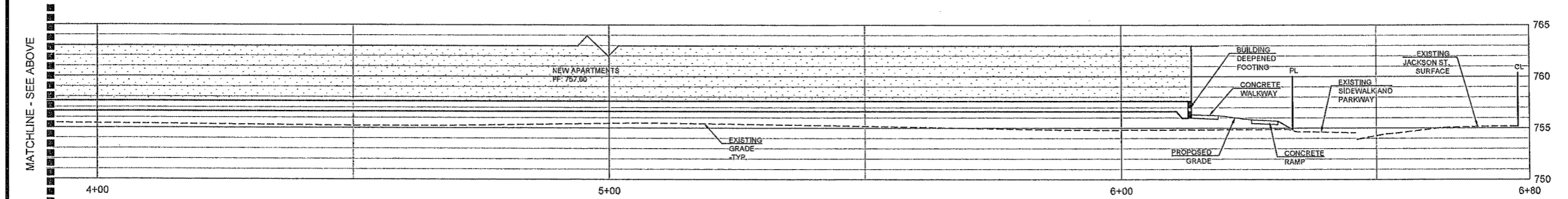

SECTION A-A (CONTINUED)  
(SCALE: 1"=10 HORIZ. 1"=5' VERT.)

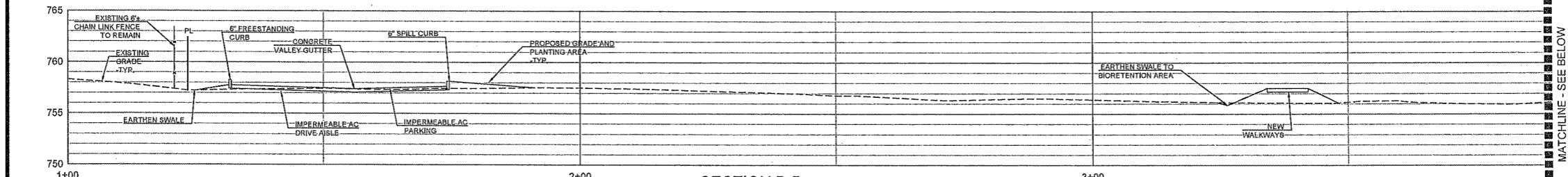

SECTION B-B  
(SCALE: 1"=10 HORIZ. 1"=5' VERT.)

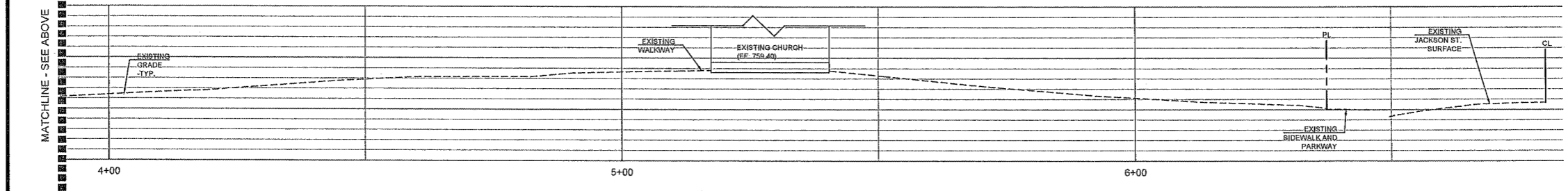

SECTION B-B (CONTINUED)  
(SCALE: 1"=10 HORIZ. 1"=5' VERT.)

**WARE MALCOLM**  
LEADING DESIGN FOR COMMERCIAL REAL ESTATE

10 Redman  
Irvine, CA 92618  
P 949.860.9128  
waremalcolm.com

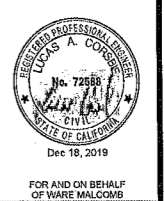

FOR AND ON BEHALF  
OF WARE MALCOLM

**ST. MICHAEL'S - RIVERSIDE**  
4070 JACKSON ST.  
RIVERSIDE, CA 92503  
PHASE 1

SITE SECTIONS	
NO.	DATE

JOB NO.:	IRV18-4039
PA / PM:	LC
DRAWN BY:	BS
DATE:	07-01-19

SHEET  
**C-3.0**  
Sheet 3 of 6

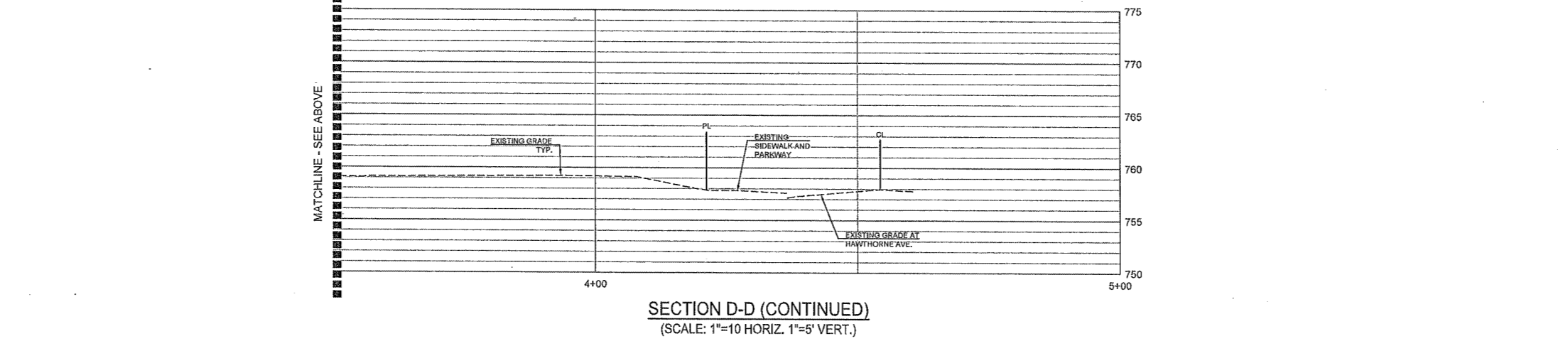
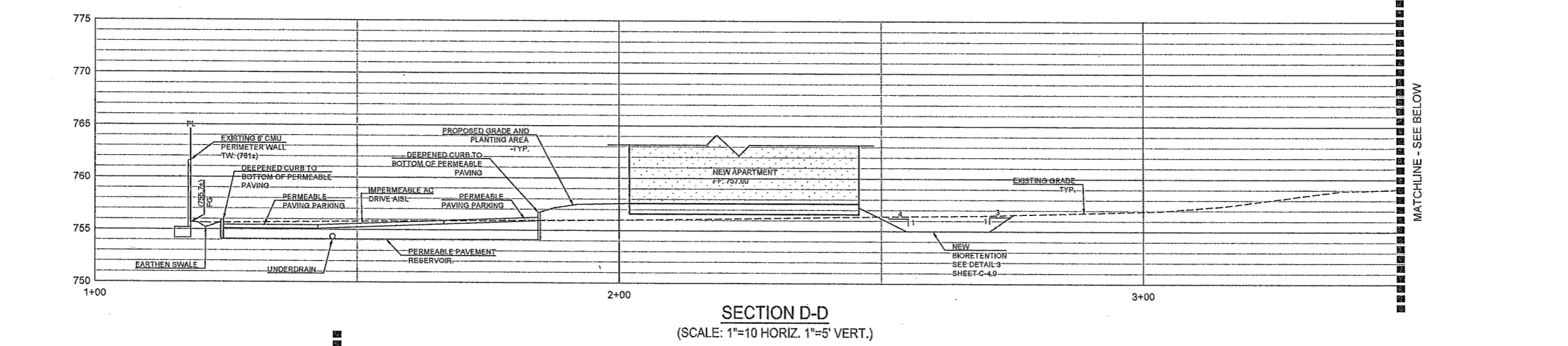
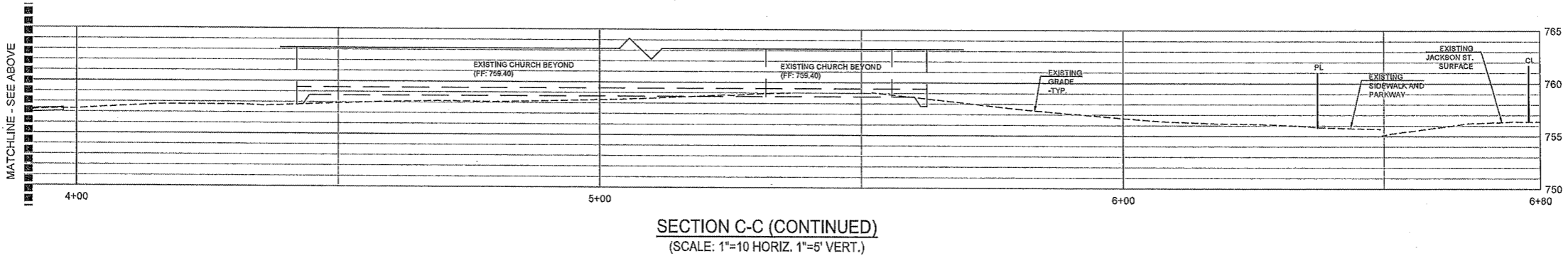
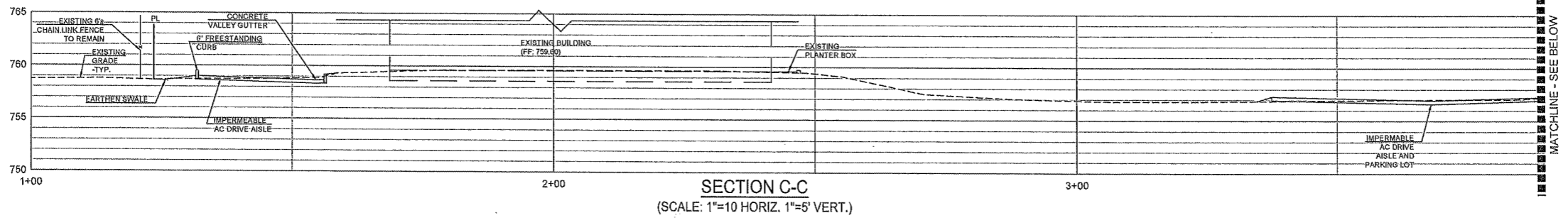

WARE MALCOMB  
LEADING DESIGN FOR COMMERCIAL REAL ESTATE

10 edelman  
irvine, ca 92618  
p 949.650.9128  
waremalcomb.com

FOR AND ON BEHALF OF WARE MALCOMB

ST. MICHAEL'S - RIVERSIDE  
4070 JACKSON ST.  
RIVERSIDE, CA 92503  
PHASE 1

SITE SECTIONS	
NO.	REMARKS

JOB NO.:	IRV18-4039
PA / PM:	LC
DRAWN BY:	BS
DATE:	07-01-19

SHEET  
**C-3.1**  
Sheet 4 of 6

THESE DRAWINGS AND SPECIFICATIONS ARE THE PROPERTY AND COPYRIGHT OF WARE MALCOMB, AND SHALL NOT BE USED ON ANY OTHER WORK EXCEPT BY AGREEMENT WITH WARE MALCOMB. WRITTEN DIMENSIONS SHALL TAKE PRECEDENCE OVER SCALED DIMENSIONS AND SHALL BE VERIFIED ON THE JOB SITE. ANY DISCREPANCY SHALL BE BROUGHT TO THE NOTICE OF WARE MALCOMB PRIOR TO THE COMMENCEMENT OF ANY WORK. PRELIMINARY - NOT FOR CONSTRUCTION

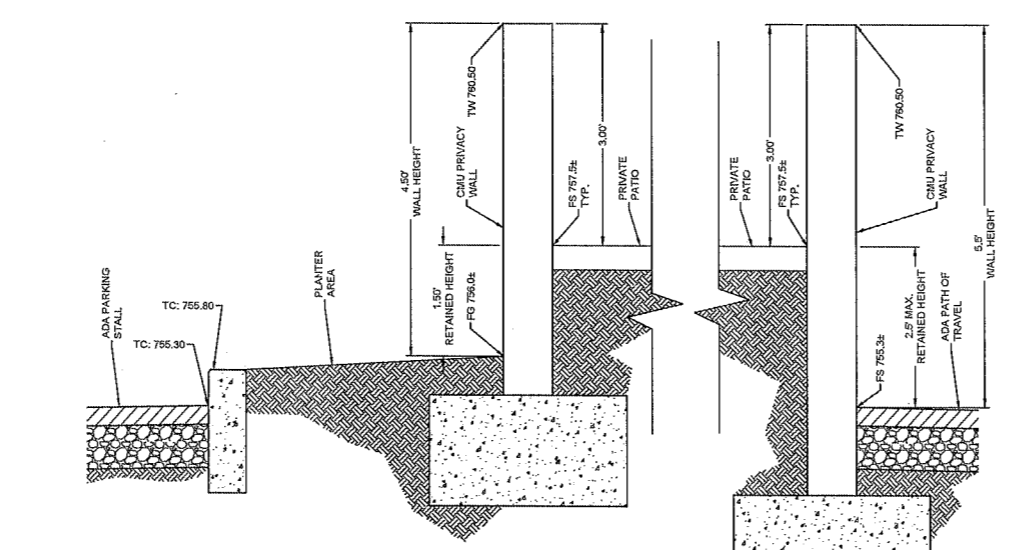
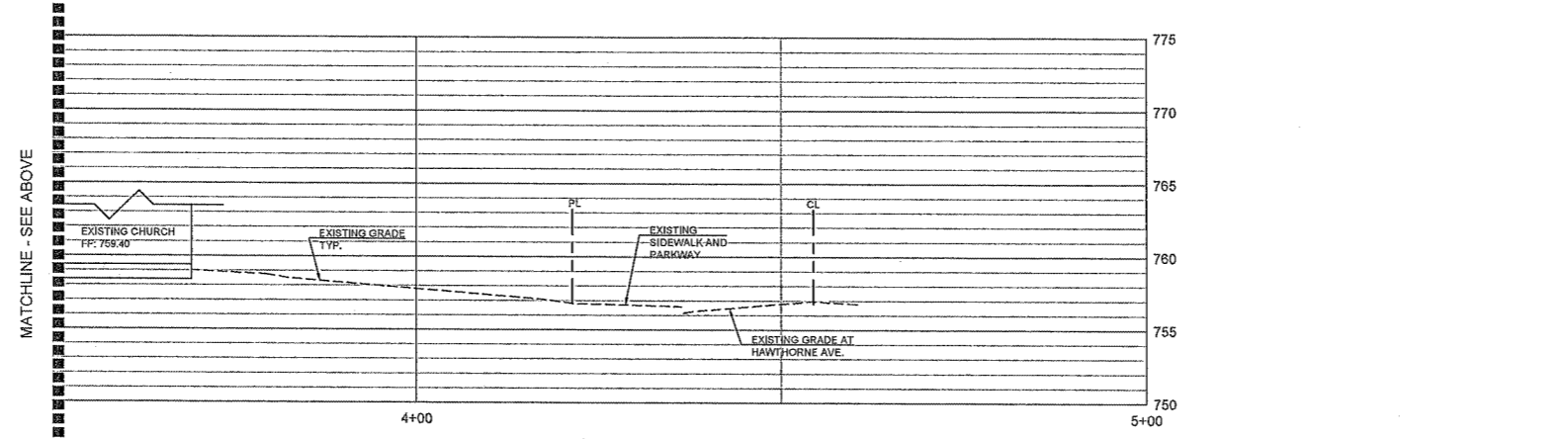
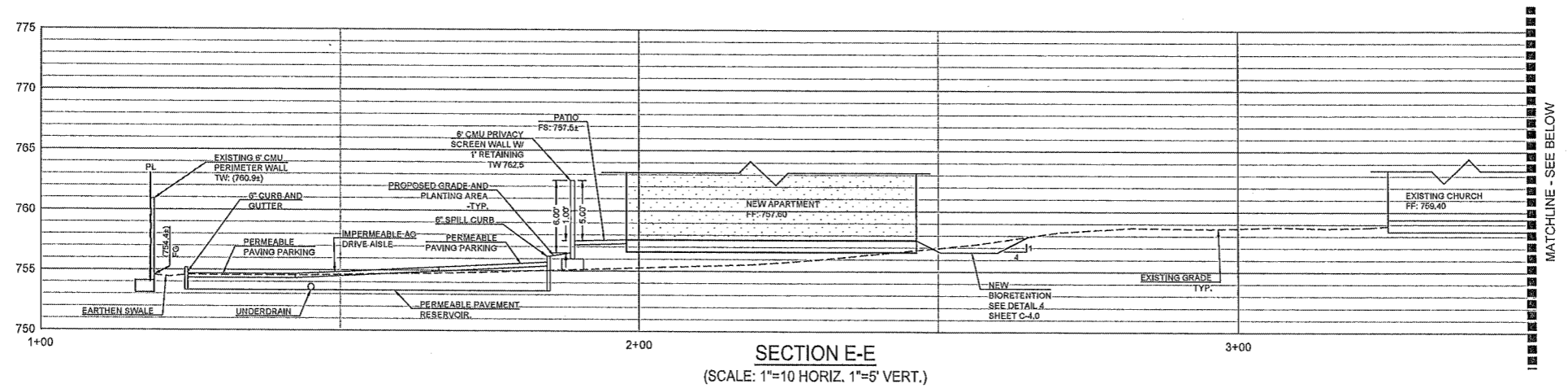

**WARE MALCOMB**  
LEADING DESIGN FOR COMMERCIAL REAL ESTATE

10 edelman  
irvine, ca 92618  
p 949.690.5128  
waremalcomb.com

**REGISTERED PROFESSIONAL ENGINEER**  
LUCAS A. COOPER  
No. 72585  
STATE OF CALIFORNIA  
CIVIL  
Dec 18, 2019

FOR AND ON BEHALF  
OF WARE MALCOMB

**ST. MICHAEL'S - RIVERSIDE**  
4070 JACKSON ST.  
RIVERSIDE, CA 92503  
PHASE 1

SITE SECTIONS	
NO.	REMARKS

JOB NO.: IRV16-4039  
PA / PM: LC  
DRAWN BY: BS  
DATE: 07-01-09

SHEET  
**C-3.2**  
Sheet 5 of 6



**WARE MALCOMB**  
LEADING DESIGN FOR COMMERCIAL REAL ESTATE

10 edelman  
irvine, ca 92618  
p 949.650.5728  
waremalcomb.com



FOR AND ON BEHALF  
OF WARE MALCOMB

**ST. MICHAEL'S - RIVERSIDE**  
4070 JACKSON ST.  
RIVERSIDE, CA 92503  
PHASE 1

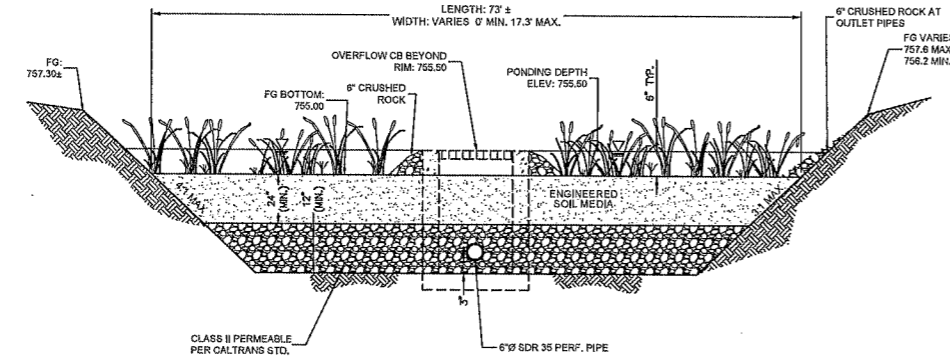

**DETAIL 3 - DMA 5 BIORETENTION SECTION**  
N.T.S.

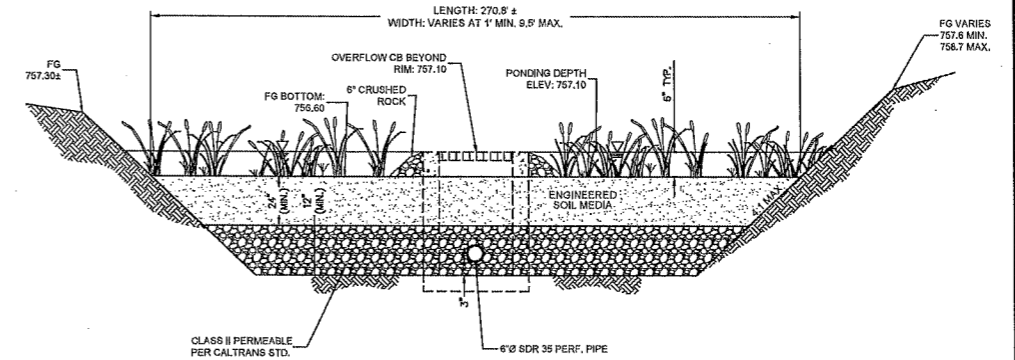

**DETAIL 4 - DMA 6 BIORETENTION SECTION**  
N.T.S.

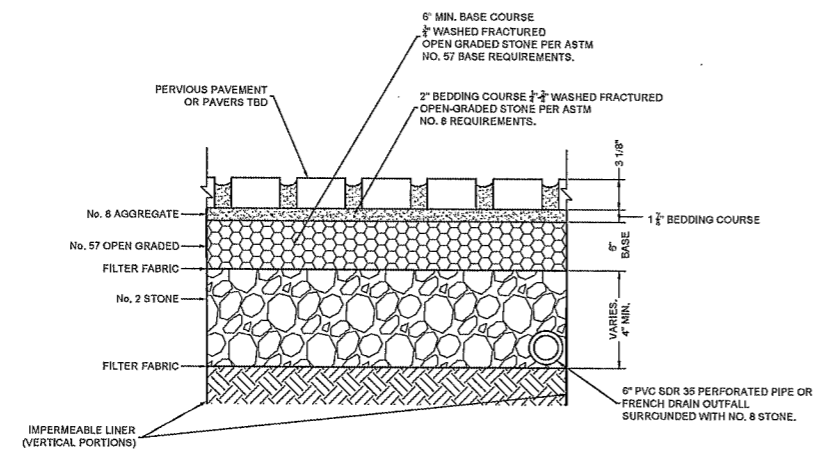

**DETAIL 5 - PERMEABLE PAVING SECTION**  
N.T.S.  
FINAL DETAILING TO BE COORDINATED WITH GEOTECHNICAL ENGINEER

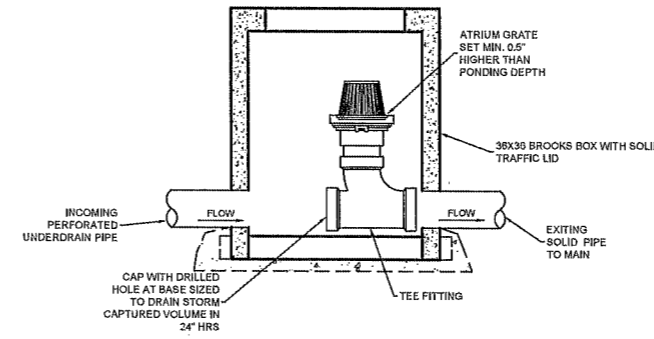

**DETAIL 6 - ORIFICE AND OVERFLOW STRUCTURE**  
N.T.S.

























BMP SECTIONS

NO.	DATE	REMARKS

JOB NO.:	IRV18-039
PA / PM:	LC
DRAWN BY:	BS
DATE:	07-01-019











SHEET  
**C-4.0**  
Sheet 6 of 6

**SYMBOLS**

-  FIRE HYDRANT
-  STREET LIGHT
-  TRAFFIC SIGNAL
-  TRAFFIC SIGNAL ARM & POLE
-  ELECTRIC METER
-  LIGHT STANDARD
-  PARKING LIGHT
-  UTILITY POLE
-  GUY WIRE & ANCHOR
-  WATER METER
-  GAS METER
-  WATER VALVE
-  GAS VALVE
-  PULL BOX
-  GRATE INLET
-  SIGN
-  SEWER MANHOLE
-  STORM DRAIN MANHOLE
-  TELEPHONE MANHOLE
-  SEWER CLEANOUT
-  HANDICAP PARKING STALL
-  LANDSCAPED AREA
-  PLOTABLE EASEMENT ITEM NO. PER TITLE REPORT
-  EXIST. CONTOUR





**LINE TYPE LEGEND**

-  CATV = CABLE TV LINE
-  E = ELECTRICAL LINE
-  G = GAS LINE
-  GB = GRADE BREAK LINE
-  R = RIDGE LINE
-  S = SEWER LINE
-  SD = STORM DRAIN LINE
-  T = TELEPHONE LINE
-  W = WATER LINE
-  SS = SANITARY LINE
-  OY = OVERHEAD UTILITY LINE

**ABBREVIATIONS**

- AB = AGGREGATE BASE
- AC = ASPHALT CONCRETE
- CF = CURB FACE
- CL = CENTERLINE
- CO = CLEANOUT
- DG = DECOMPOSED GRANITE
- FD = FOUND
- FF = FINISHED FLOOR
- FG = FINISHED GRADE
- FH = FIRE HYDRANT
- FL = FLOW LINE
- FS = FINISHED SURFACE
- GB = GRADE BREAK
- GM = GAS METER
- GR = TOP OF GRATE
- GV = GAS VALVE
- HT = HEIGHT
- IP = IRON PIPE
- LS = LIGHT STANDARD
- LAT = LEAD & TAG
- MH = MANHOLE
- NG = NATURAL GROUND
- N&T = NAIL & TAG
- PA = PLANTING AREA
- PB = PULL BOX
- PCG = CONCRETE
- PL = PROPERTY LINE
- SMH = SEWER MANHOLE
- SPK = SPIKE
- SW = SIDEWALK
- TC = TOP OF CURB
- W = WASHER
- WM = WATER METER
- WV = WATER VALVE
- N = NORTH
- S = SOUTH
- E = EAST
- W = WEST
- NLY = NORTHERLY
- SLY = SOUTHERLY
- Ely = EASTERLY
- Wly = WESTERLY
- N/O = NORTH OF
- S/O = SOUTH OF
- E/O = EAST OF
- W/O = WEST OF
- C = PROPERTY LINE
- CL = CENTERLINE
- RAV = RIGHT OF WAY
- Δ = DELTA
- R = RADIUS
- L = LENGTH
- T = TANGENT
- (RAD) = RADIAL BEARING
- (427.00) TC = EXISTING ELEVATION

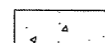
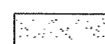
**HATCH LEGEND**

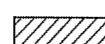
-  CONCRETE OR MISC. HARDSCAPE
-  ASPHALT CONCRETE
-  NEW STRUCTURE
-  BIO-RETENTION

# CONCEPTUAL GRADING AND PRELIMINARY UTILITY PLAN

ST. MICHAEL'S - RIVERSIDE  
4070 JACKSON ST.  
RIVERSIDE, CA 92503

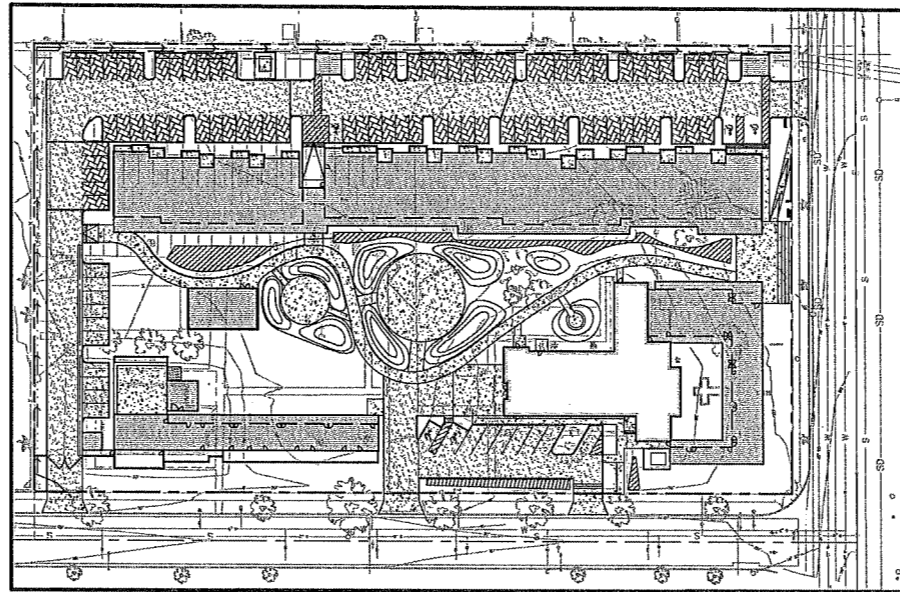

**OVERALL SITE**

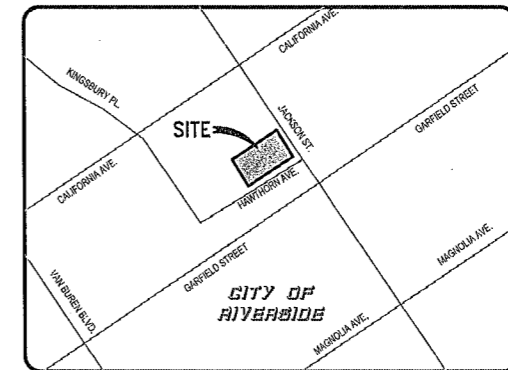
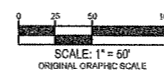

VICINITY MAP  
NOT TO SCALE

**DEVELOPER:**

COMMUNITY DEVELOPMENT PARTNERS  
3418 VIA OPIRITO, SUITE 301  
NEWPORT BEACH, CA 92663  
949-467-1344

**CIVIL:**

WARE MALCOMB  
10 EDELMAN  
IRVINE, CA 92618  
ATTN: LUCAS CORRSIE  
949-669-9128 EXT: 1159

**ARCHITECT**

ESCHER GUNWARDENA ARCHITECTURE  
815 SILVER LAKE BLVD  
LOS ANGELES, CA  
ATTN: DANIEL CARLSON  
323-665-9100

**GEOTECHNICAL ENGINEER:**

ENGEO INC.  
8 MORGAN, SUITE 102  
IRVINE, CA 92618  
PRELIM REPORT / PROJECT # 18031.000.000  
909-629-3479

**LAND SURVEYOR:**

EPS GROUP, INC.  
3002 DOW AVENUE, SUITE 314  
TUSTIN, CA 92780  
ATTN: NICK OWEN  
714-388-6068

**GENERAL CONTRACTOR:**

TBD

**EARTHWORK ESTIMATE**

GENERAL	CUT (CY)	FILL (CY)
NET (IMPORT)	250	4,285
		3,705

NOTE: THE ESTIMATED QUANTITIES HEREON ARE ONLY FOR THE PURPOSE OF OBTAINING THE NECESSARY PERMITS. WARE MALCOMB DOES NOT GUARANTEE THE ACCURACY OF THE ESTIMATED QUANTITIES. THE CONTRACTOR SHALL PERFORM HIS OWN QUANTITY TAKEOFF BEFORE SUBMITTING A BID FOR ANY PORTION OF THE IMPROVEMENTS COVERED BY THESE PLANS.

**SHEET INDEX**

SHEET NO.	TITLE SHEET AND SECTIONS
SHEET C-1.1	CONCEPTUAL GRADING AND PRELIMINARY UTILITY PLAN
SHEET C-2.0	SITE SECTIONS
SHEET C-3.0	SITE SECTIONS
SHEET C-3.1	SITE SECTIONS
SHEET C-3.2	SITE SECTIONS
SHEET C-4.0	BMP SECTIONS AND DETAILS

TYPICAL SECTION AT NW'LY PL

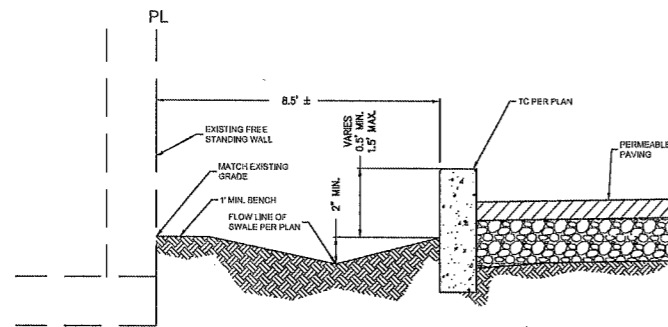

TYPICAL SECTION AT SW'LY PL

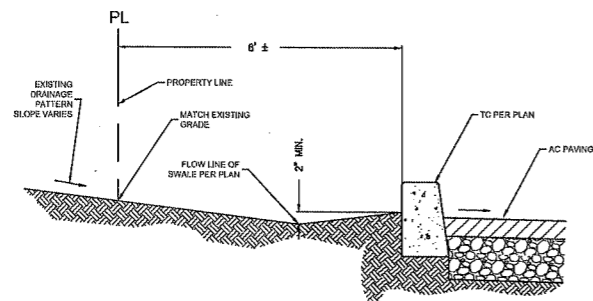

THESE DRAWINGS AND SPECIFICATIONS ARE THE PROPERTY AND COPYRIGHT OF WARE MALCOMB. ANY DISCREPANCY SHALL BE BROUGHT TO THE ATTENTION OF WARE MALCOMB PRIOR TO THE COMMENCEMENT OF ANY WORK. WRITTEN DIMENSIONS SHALL TAKE PRECEDENCE OVER SCALED DIMENSIONS AND SHALL BE VERIFIED ON THE JOB SITE. ANY DISCREPANCY SHALL BE BROUGHT TO THE ATTENTION OF WARE MALCOMB PRIOR TO THE COMMENCEMENT OF ANY WORK.

**WARE MALCOMB**  
LEADING DESIGN FOR COMMERCIAL REAL ESTATE

10 Edelman  
Irvine, CA 92618  
P 949.669.9128  
waremalcomb.com



FOR AND ON BEHALF  
OF WARE MALCOMB

**ST. MICHAEL'S - RIVERSIDE**  
4070 JACKSON ST.  
RIVERSIDE, CA 92503

NO.	DATE	REMARKS

JOB NO.:	IRV18-1039
PA / PM:	LC
DRAWN BY:	BS
DATE:	07-01-19

SHEET  
**C-1.0**  
Sheet 1 of 6

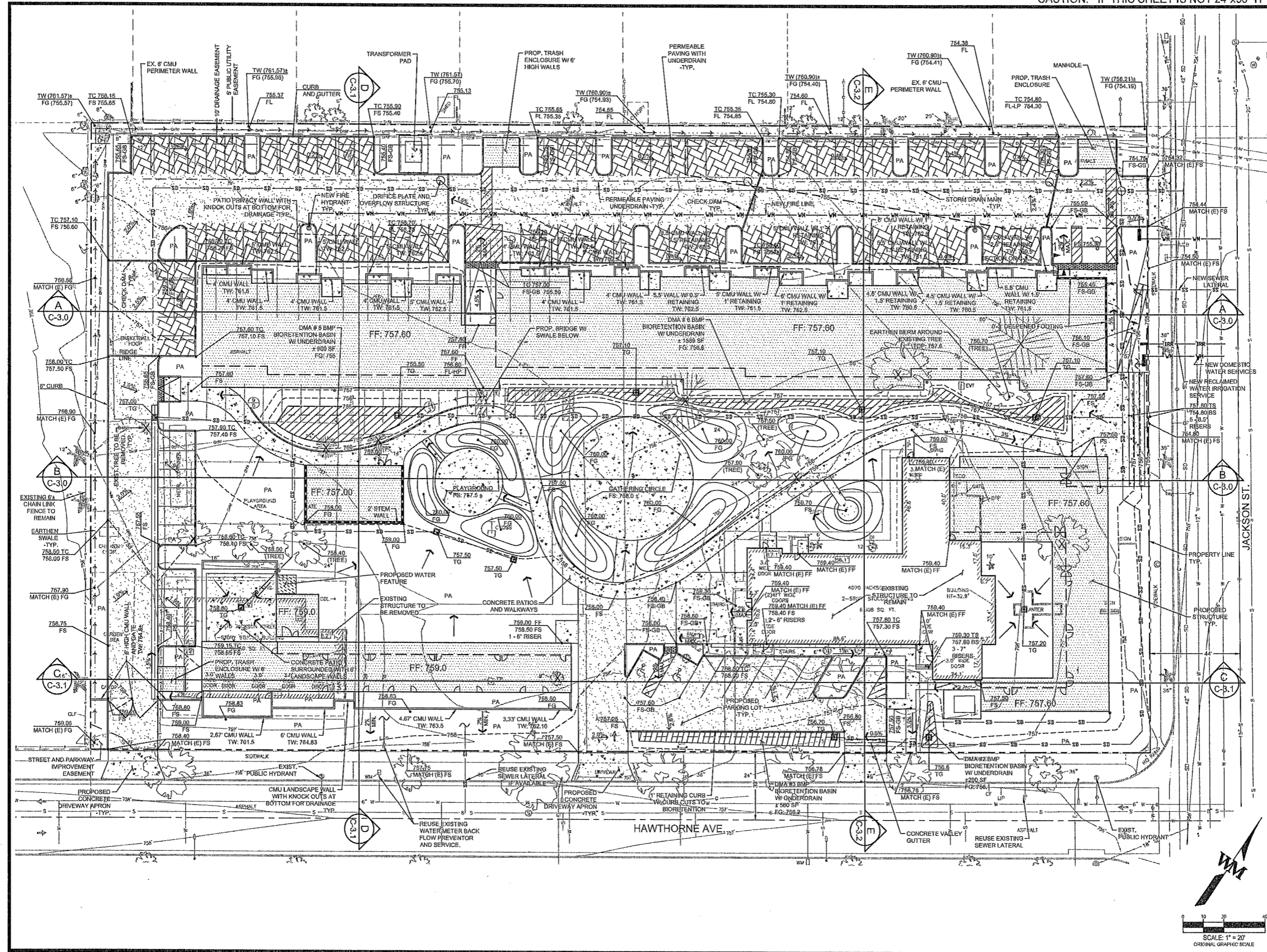

**WARE MALCOMB**  
LEADING DESIGN FOR COMMERCIAL REAL ESTATE

10 edelman  
Irvine, CA 92618  
p 949.650.9128  
waremalcomb.com



FOR AND ON BEHALF  
OF WARE MALCOMB

**ST. MICHAEL'S - RIVERSIDE**  
4070 JACKSON ST.  
RIVERSIDE, CA 92503

CONCEPTUAL GRADING AND UTILITY PLAN

JOB NO.:	IRV16-4039
PA / PM:	LC
DRAWN BY:	BS
DATE:	07-01-19

SHEET  
**C-2.0**  
Sheet 2 of 6

P19-0507 (CUP) & P19-0508 (DR), Exhibit 7 - Project Plans



CAUTION: IF THIS SHEET IS NOT 24"x36" IT IS A REDUCED PRINT

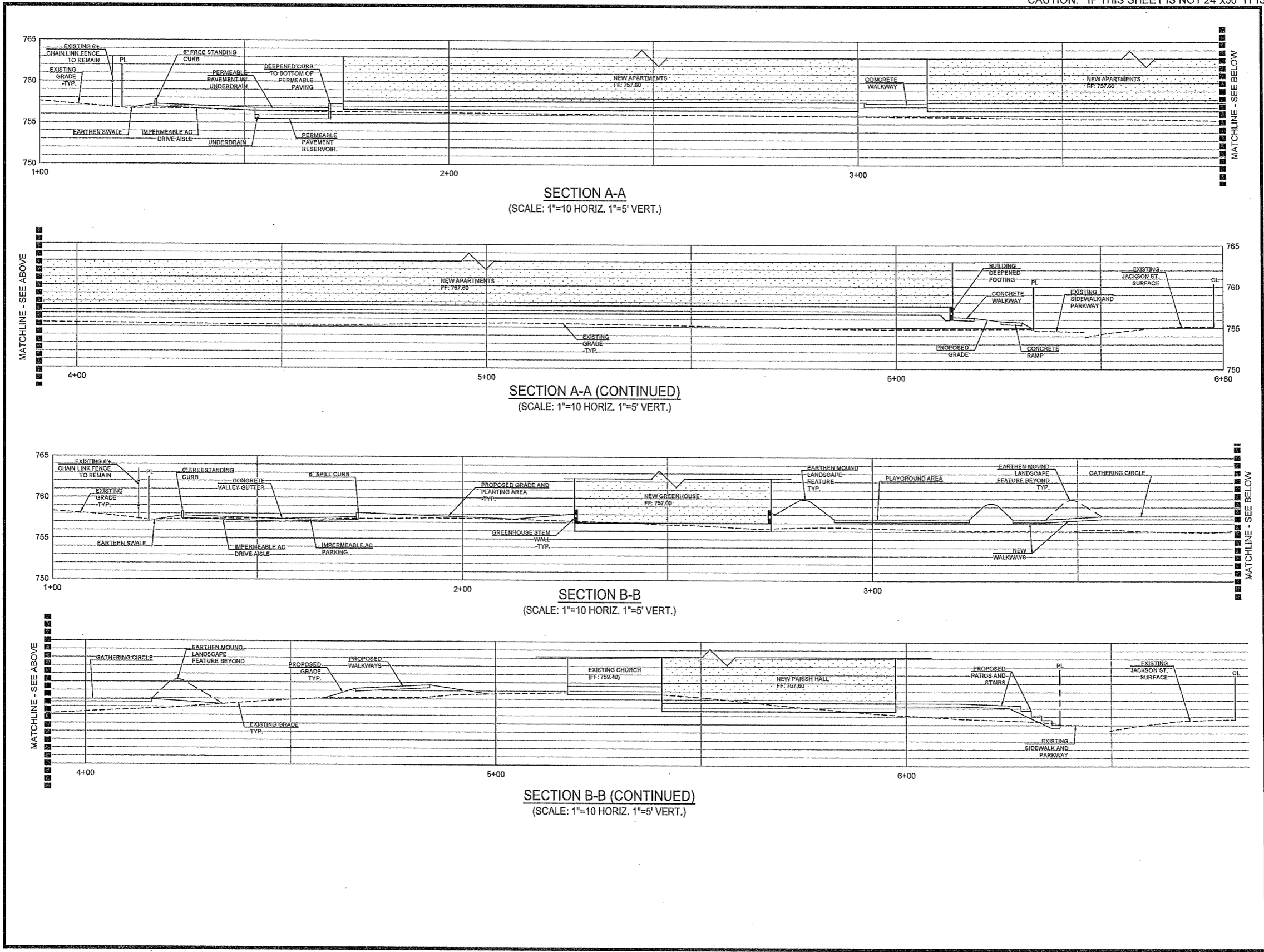

**WARE MALCOMB**  
LEADING DESIGN FOR COMMERCIAL REAL ESTATE

10 edelman  
lyfinc ca 92618  
p 949.690.9128  
waremalcomb.com

FOR AND ON BEHALF  
OF WARE MALCOMB

**ST. MICHAEL'S - RIVERSIDE**  
4070 JACKSON ST.  
RIVERSIDE, CA 92503

SITE SECTIONS	
NO.	REMARKS

JOB NO.: IRV18-4039  
PA / PM: LC  
DRAWN BY: BS  
DATE: 07-01-18

SHEET  
**C-3.0**  
Sheet 3 of 6

CAUTION: IF THIS SHEET IS NOT 24"x36" IT IS A REDUCED PRINT

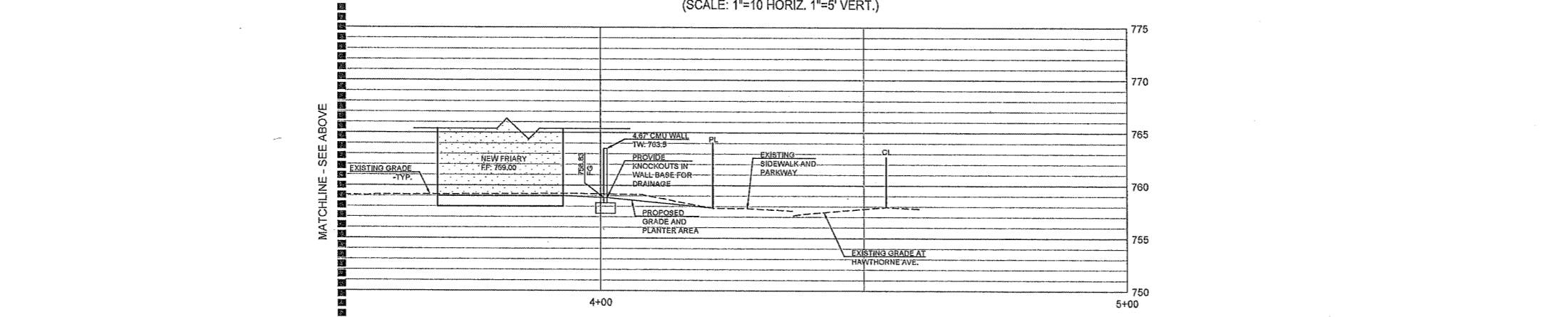
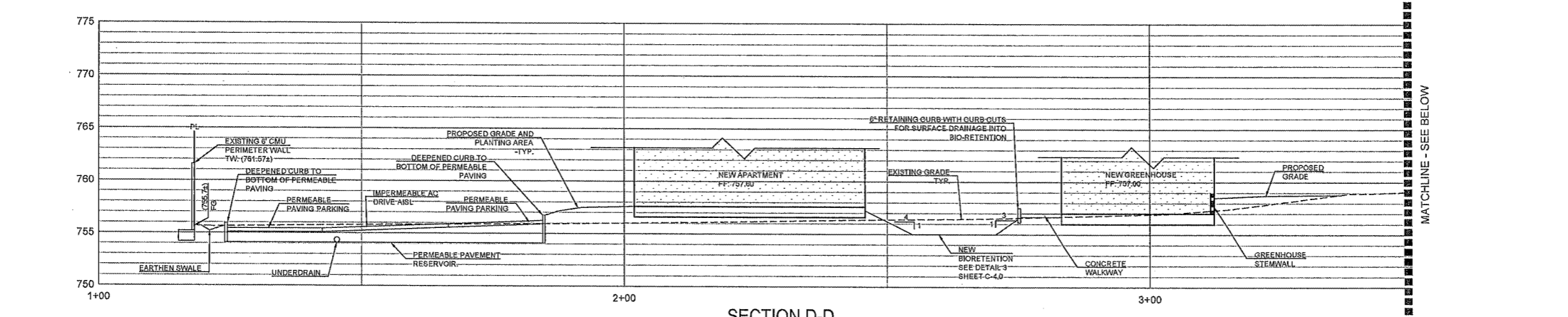
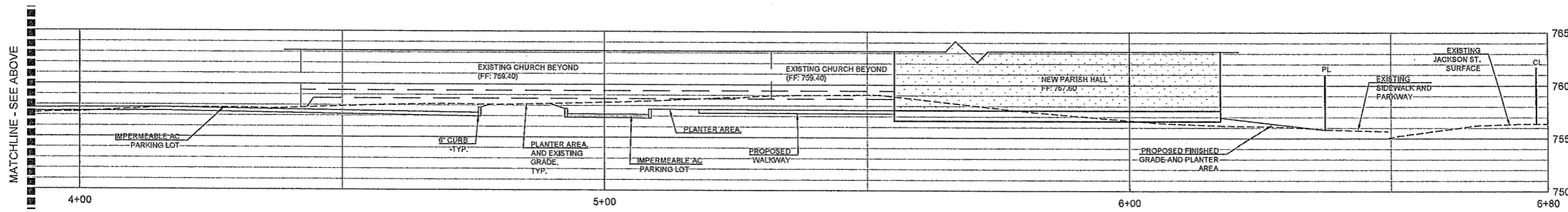
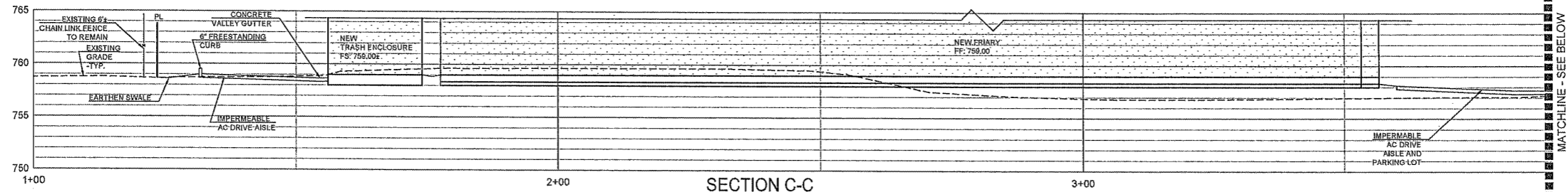

**WARE MALCOMB**  
LEADING DESIGN FOR COMMERCIAL REAL ESTATE

10 edelman  
 Irvine, CA 92618  
 P 949.660.9128  
 wmalcomb.com

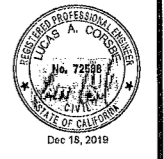

FOR AND ON BEHALF  
OF WARE MALCOMB

**ST. MICHAEL'S - RIVERSIDE**  
4070 JACKSON ST.  
RIVERSIDE, CA 92503

NO.	DATE	REMARKS

JOB NO.:	IRV16-4039
PA / PM:	LC
DRAWN BY:	BS
DATE:	07-01-19

SHEET  
**C-3.1**  
Sheet 4 of 6

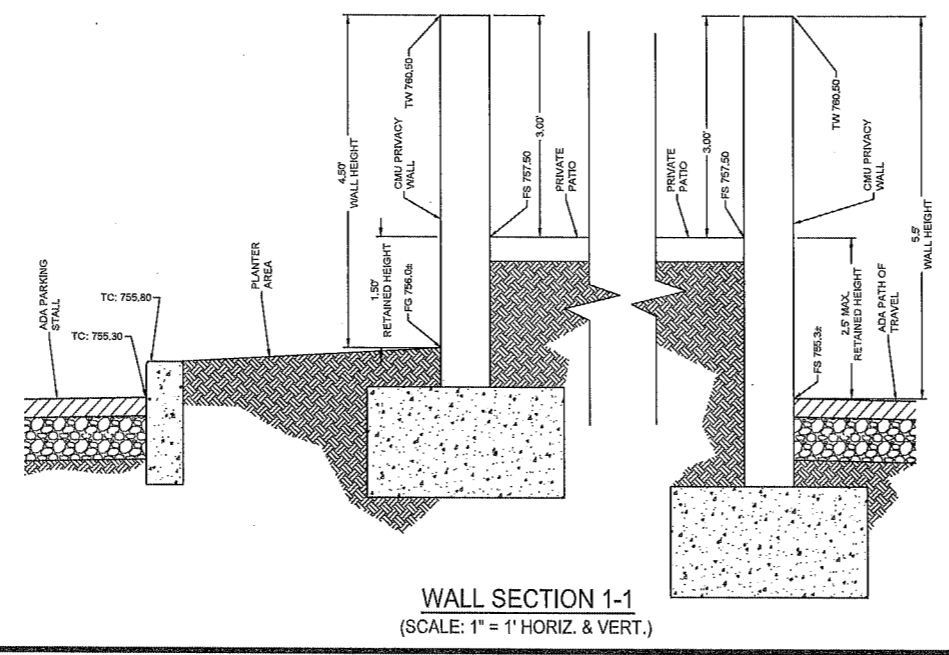
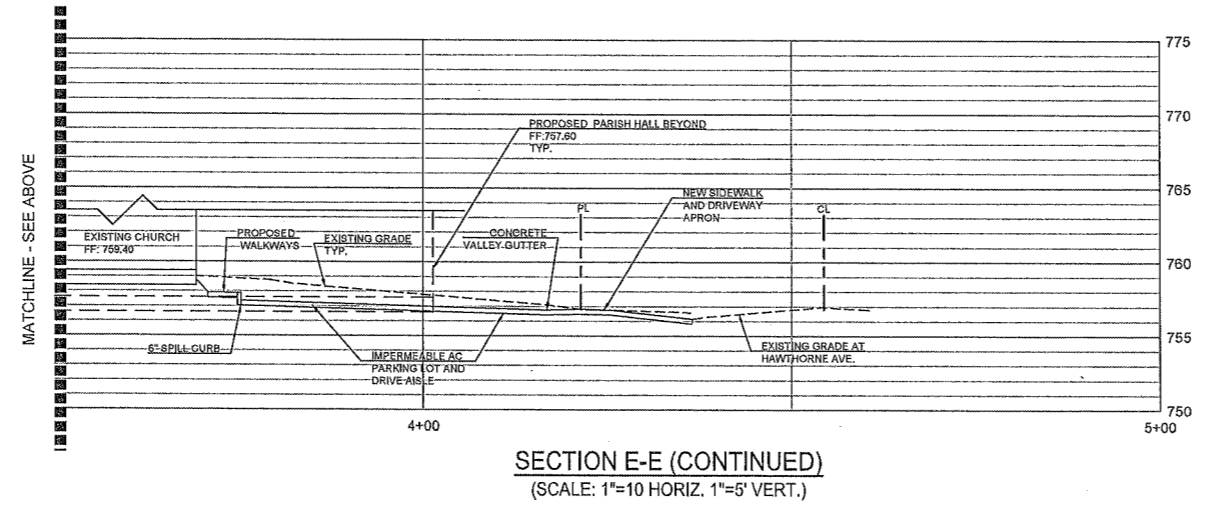
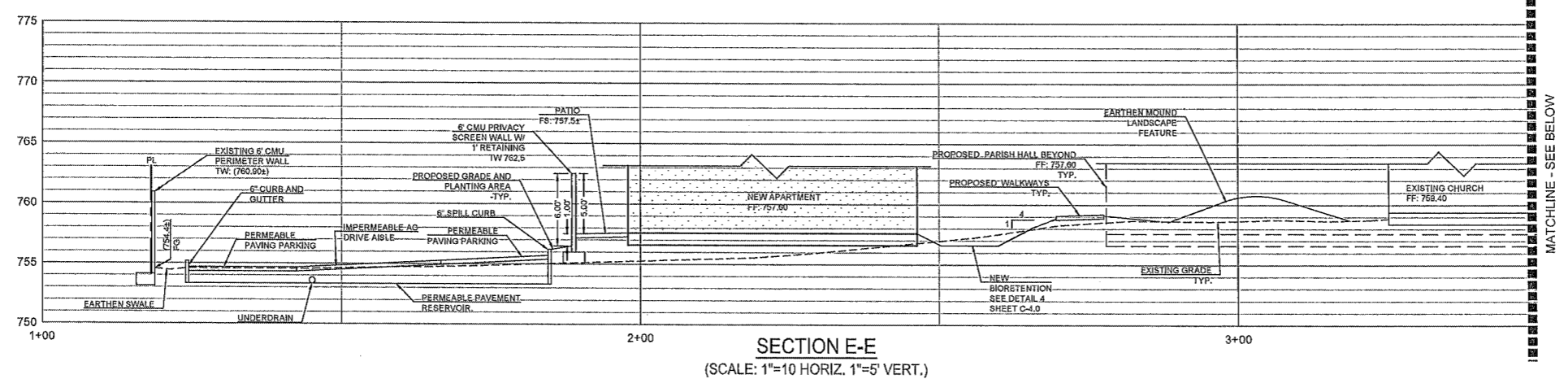

**WARE MALCOMB**  
LEADING DESIGN FOR COMMERCIAL REAL ESTATE

10 edelman  
Irvine, CA 92618  
p 949.660.3728  
waremalcomb.com

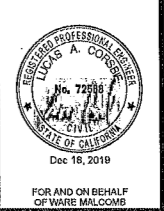

FOR AND ON BEHALF  
OF WARE MALCOMB

**ST. MICHAEL'S - RIVERSIDE**  
4070 JACKSON ST.  
RIVERSIDE, CA 92503

SITE SECTIONS	
NO.	REMARKS

  

JOB NO.:	IRV18-4039
PA / PM:	LC
DRAWN BY:	BS
DATE:	07-01-2019

SHEET	
<b>C-3.2</b>	
Sheet	5 of 6

PRELIMINARY - NOT FOR CONSTRUCTION

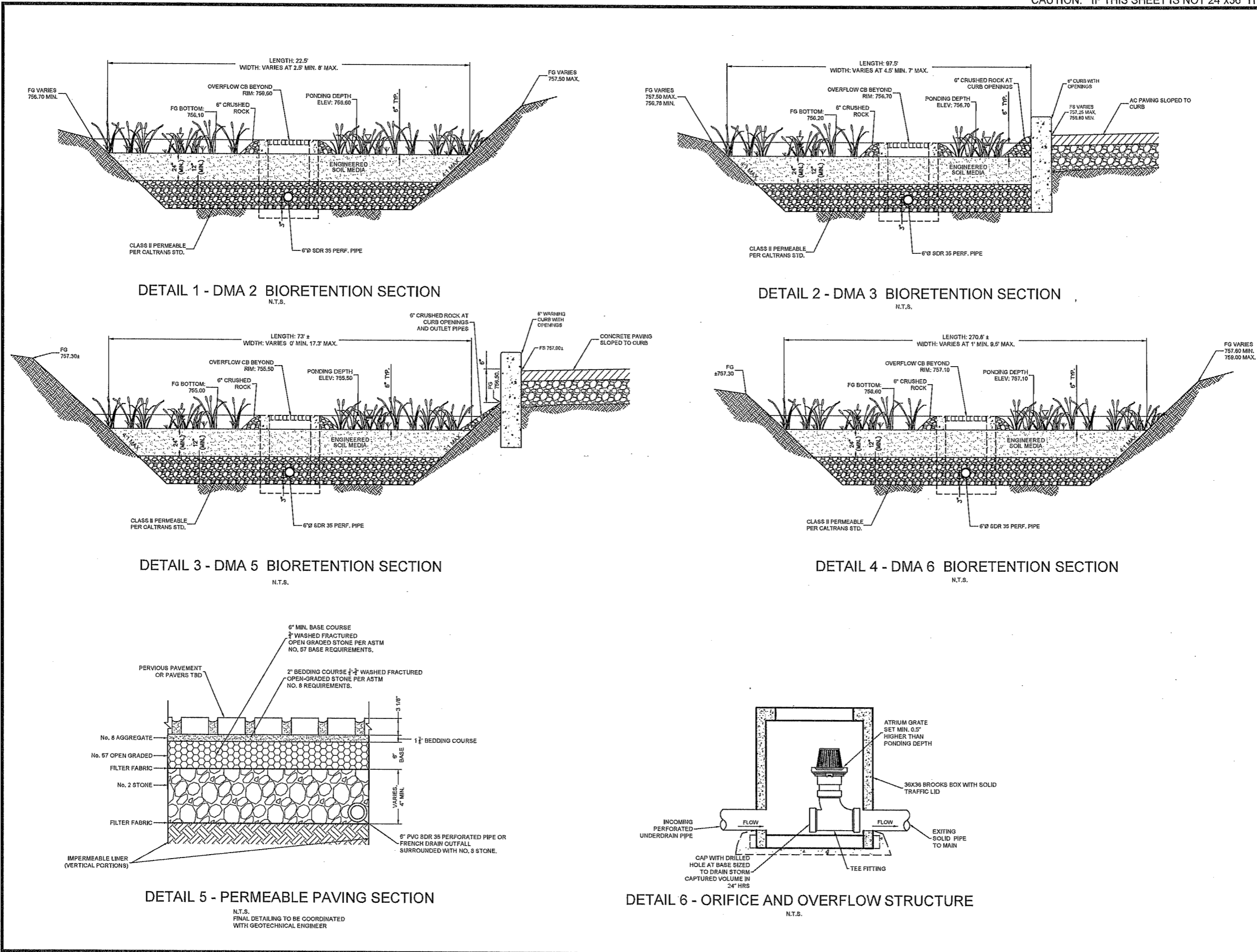

**WARE MALCOMB**  
LEADING DESIGN FOR COMMERCIAL REAL ESTATE

10 eelham  
irvine, ca 92618  
p 949.850.9728  
waremalcomb.com

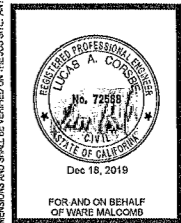

**ST. MICHAEL'S - RIVERSIDE**  
4070 JACKSON ST.  
RIVERSIDE, CA 92503

BMP SECTIONS	DATE	REMARKS

JOB NO.:	IRV18-4038
DATE:	LC
DRAWN BY:	BS
DATE:	07-01-019

SHEET  
**C-4.0**  
Sheet 6 of 6



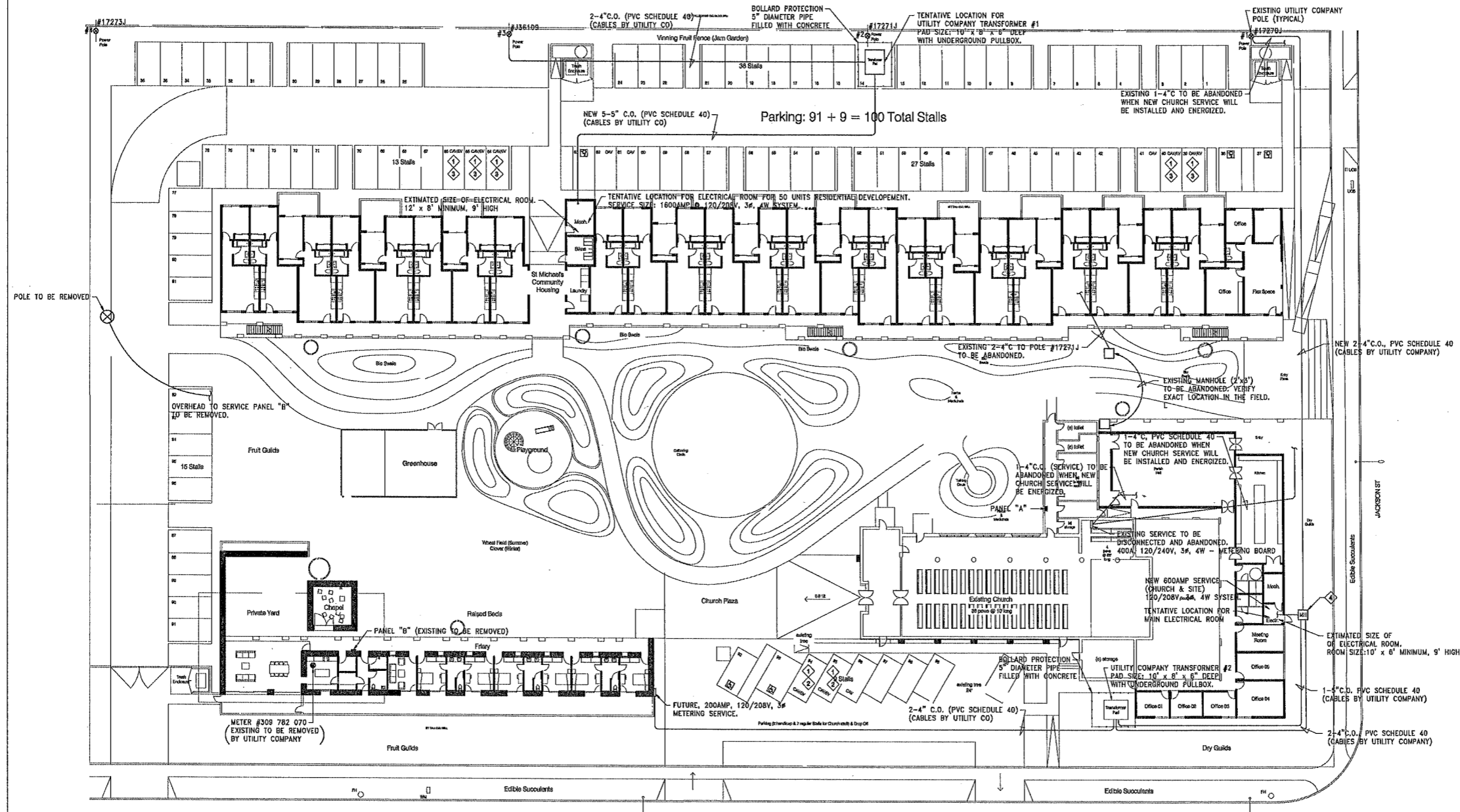

**PRELIMINARY ELECTRICAL SITE PLAN**  
 SCALE 1" = 20'-0"

**NUMBERED NOTES - (THIS SHEET ONLY)**

- ◇ PARKING SPACE EQUIPPED FOR FUTURE CAR CHARGING STATION.
- ◇ CAR CHARGING STATION TO BE FED FROM CHURCH METER.
- ◇ CAR CHARGING STATION TO BE FED FROM RESIDENTIAL UNITS HOUSE PANEL.
- ◇ MANHOLE 4' x 4' x 3' DEEP PRECAST CONCRETE WITH TRAFFIC COVER

**NOTE**

SITE DISTRIBUTION, LOCATION OF UTILITY COMPANY TRANSFORMERS AND CONDUITS SIZES AND ROUTES ARE IN ACCORDANCE WITH THE CITY OF RIVERSIDE CONCEPTUAL PLAN, SHEET C-2.0. LOCATION OF PULLBOXES, MANHOLES, HANDHOLES, ETC. WILL BE FINALIZED DURING COMPLETION OF SITE ELECTRICAL SERVICES DISTRIBUTION LAYOUT PHASE.

615 Silver Lake Boulevard  
 Los Angeles, California 90026  
 Tel: 323 665 9100 Fax: 323 665 9103

**Escher  
 Gunewardena  
 Architecture**



**ELECTRICAL SITE PLAN**

drawn by:  
 scale:  
 issue date:  
 plot date:

**Y & M ELECTRICAL ENGINEERING, INC.**  
 3330 Borham Boulevard, Suite 204  
 Los Angeles, CA 90068  
 (323) 651-9864 Fax (323) 651-0153  
 E-mail: yme@ymelectrical.com

**E-3**

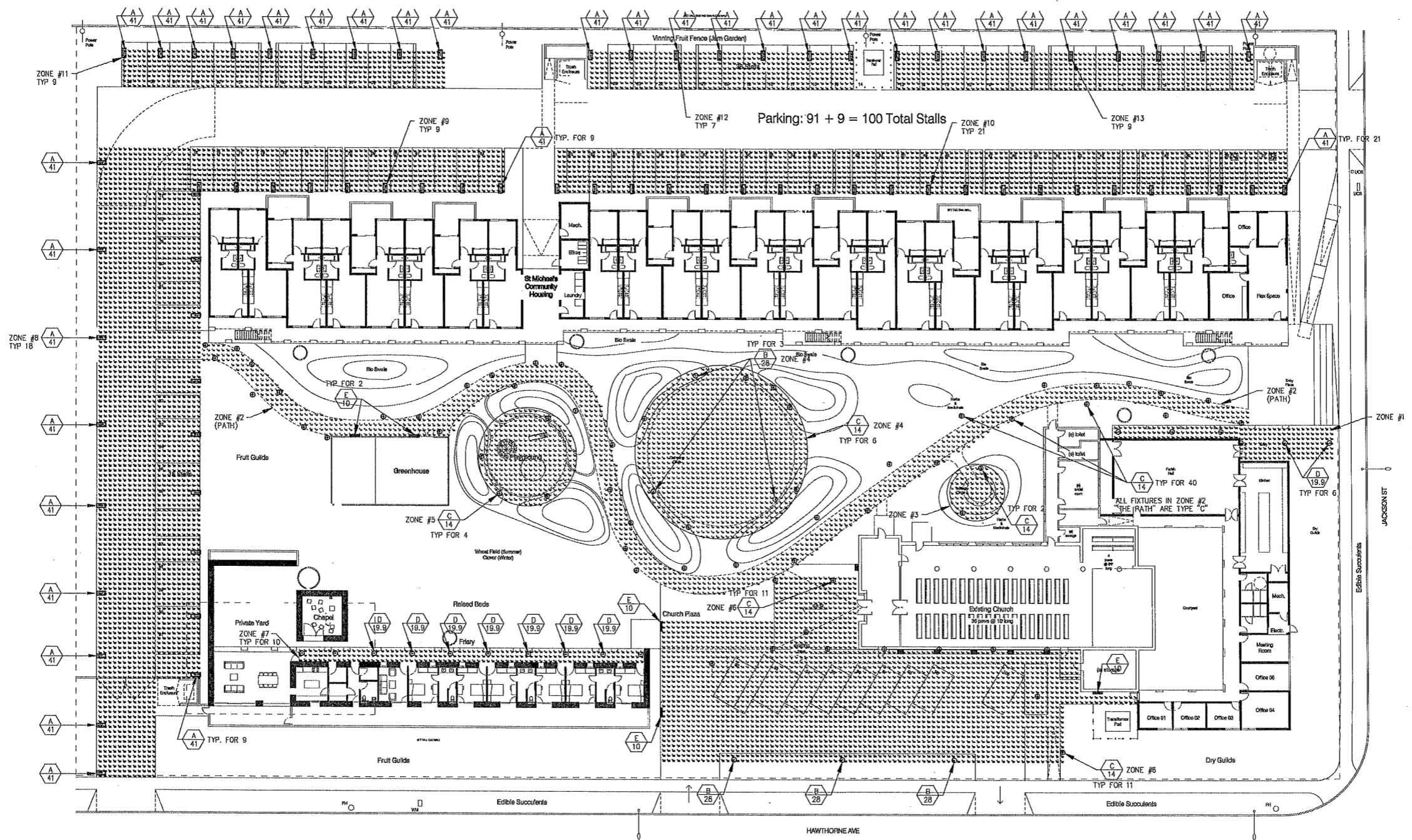

**PRELIMINARY ELECTRICAL SITE PLAN**

SCALE: NOT APPLICABLE



Symbol	Level	Quantity	Manufacturer	Building Number	Description	Wattage	Number Lamps	Footcandle	Lumens Per Lamp	Light Loss Factor	Usage
⊕	A	11	OSRAM	11	OSRAM COMPACT FLUORESCENT (11.250W) / 11.250W	11.250W	1	11.250 FC	11.250 LM	0.80	11
⊙	B	11	OSRAM	11	OSRAM COMPACT FLUORESCENT (11.250W) / 11.250W	11.250W	1	11.250 FC	11.250 LM	0.80	11
⊕	C	11	OSRAM	11	OSRAM COMPACT FLUORESCENT (11.250W) / 11.250W	11.250W	1	11.250 FC	11.250 LM	0.80	11
⊙	D	11	OSRAM	11	OSRAM COMPACT FLUORESCENT (11.250W) / 11.250W	11.250W	1	11.250 FC	11.250 LM	0.80	11
⊕	E	11	OSRAM	11	OSRAM COMPACT FLUORESCENT (11.250W) / 11.250W	11.250W	1	11.250 FC	11.250 LM	0.80	11

Description	Symbol	Avg	Max	Min	Max/Min	Avg/Min
Calc Zone #1	+	7.0 fc	14.3 fc	1.6 fc	8.9:1	4.4:1
Calc Zone #2	+	2.1 fc	4.8 fc	0.5 fc	9.6:1	4.2:1
Calc Zone #3	+	1.7 fc	3.2 fc	0.7 fc	4.6:1	2.4:1
Calc Zone #4	+	2.7 fc	6.5 fc	0.7 fc	9.3:1	3.8:1
Calc Zone #5	+	1.7 fc	2.4 fc	0.7 fc	3.4:1	2.4:1
Calc Zone #6	+	1.8 fc	6.2 fc	0.4 fc	15.5:1	4.0:1
Calc Zone #7	+	8.1 fc	10.3 fc	6.8 fc	1.5:1	1.3:1
Calc Zone #8	+	5.4 fc	8.7 fc	1.0 fc	10.8:1	6.1:1
Calc Zone #9	+	7.9 fc	13.2 fc	1.4 fc	9.4:1	5.8:1
Calc Zone #10	+	8.0 fc	12.9 fc	1.4 fc	9.2:1	5.7:1
Calc Zone #11	+	7.5 fc	11.8 fc	1.0 fc	11.8:1	7.5:1
Calc Zone #12	+	8.3 fc	9.9 fc	1.0 fc	9.9:1	8.3:1
Calc Zone #13	+	8.3 fc	10.1 fc	1.0 fc	10.1:1	8.3:1

615 Silver Lake Boulevard  
Los Angeles, California 90028  
Tel: 323 665 8100 Fax: 323 665 9103

**Escher  
Gunewardena  
Architecture**



**SITE PLAN PHOTOMETRICS**

drawn by:  
scale:  
issue date:  
plot date:

**V & M ELECTRICAL ENGINEERING, INC.**  
3330 Borham Boulevard, Suite 204  
Los Angeles, CA 90058  
(323) 851-9894 Fax (323) 851-0153  
E-mail: vme@vmelectrical.com

**E-4**

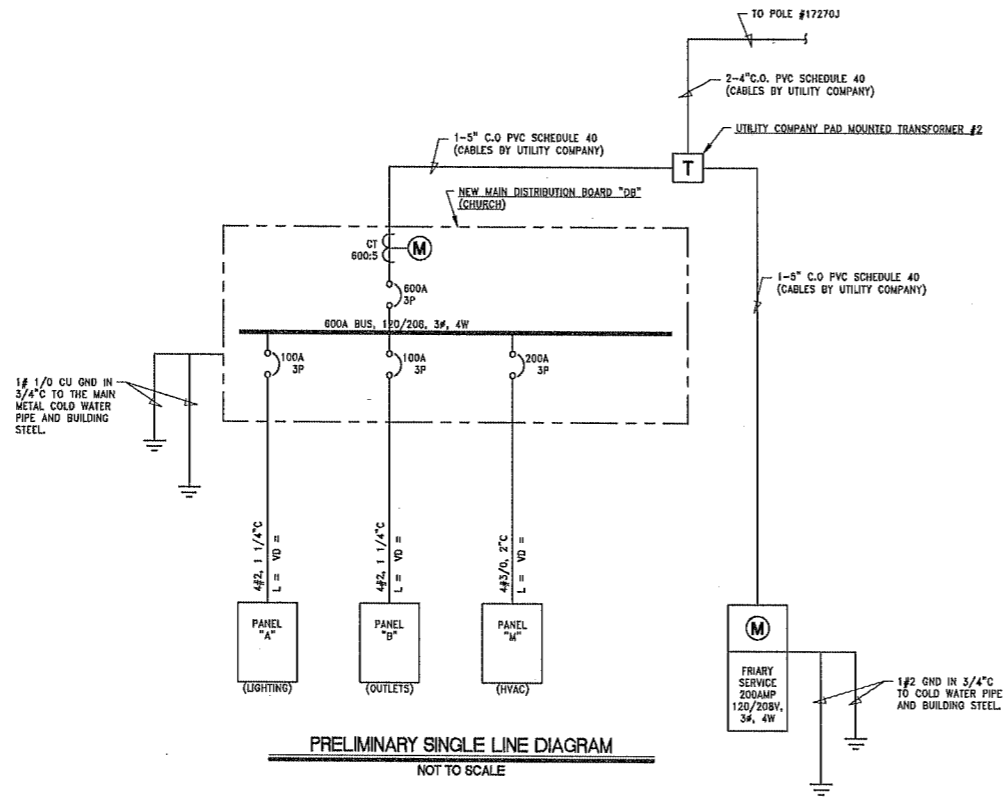

**LOAD CALCULATIONS**

- A. CHURCH LOAD CALCULATIONS:  
ESTIMATED NEW TOTAL AREA - 9,300 SQ. FT.
1. LIGHTING ESTIMATE (NEC TABLE 220.12)  
1 WATT/SQ FT = 9,300 WATT  
HVAC: ASSUME 6 WATT/SF  
6 WATT x 9,300 SQ FT = 55,800 SQ FT
  2. MISC.  
ASSUME 3 WATT/SF  
3 WATT x 9,300 SQ FT = 27,900 SQ FT  
TOTAL: 93,000 SQ FT OR  
258 AMP @ 120/208V, 3φ, 4W SYSTEM
  3. CAR CHARGING STATIONS.  
2 STATIONS @ 40AMP, 240, 1 PHASE: 7680 WATT x 2, 15,360 WATT x 1.25 = 19,200 WATT  
OR 55AMP @ 120/208V, 3PHASE, 4 WIRE
- SITE LIGHTING, GREEN HOUSE, ETC.  
ASSUME 50 AMP @ 120/208V, 3φ, 4 WIRE SYSTEM  
TOTAL CHURCH: 258AMP + 55AMP + 50AMP = 363AMP  
SERVICE SHALL BE 600AMP @ 120/208V, 3φ, 4W
- B. FRIARY: ESTIMATED AREA 3,500 SQ FT  
(SAME WATTS PER SQUARE FOOT AS FOR THE CHURCH)
- TOTAL: 35,000 WATT OR  
97 AMP @ 120/208V, 3φ, 4W SYSTEM  
SERVICE TO BE 200AMP, 120/208V, 3φ, 4W.

Escher  
Günewardena  
Architecture



ELECTRICAL LEGEND, ABBREVIATIONS  
& ELECTRICAL SPECIFICATIONS

drawn by:  
scale:  
issue date:  
plot date:

E-5

V. R. M. ELECTRICAL ENGINEERING, INC.  
3330 Borham Boulevard, Suite 204  
Los Angeles, CA 90068  
(323) 951-9984 Fax (323) 951-0153  
E-MAIL: VRRM@VRRMELECTRICAL.COM