

Canyon Crest Bus Stop Improvement Project

FUNDING, CONSTRUCTION AND CONSTRUCTION MANAGEMENT AGREEMENT

BETWEEN

RIVERSIDE TRANSIT AGENCY

AND

CITY OF RIVERSIDE

This Cooperative Agreement ("Agreement") is entered into on this ____ day of _____, 2021 by and between the CITY OF RIVERSIDE, a California charter city and a municipal corporation ("City") and the RIVERSIDE TRANSIT AGENCY, a joint powers public transit Agency, established pursuant to California Government Code Sections 6500, et seq. ("Agency"). Hereinafter, the City and the Agency may be referred to collectively as the "Parties."

RECITALS

A. Agency desires to partner with the City to construct six (6) sawtooth bus bays, bus pads and amenities on Canyon Crest Drive in the City of Riverside as described in Exhibit "A" attached hereto and incorporated herein by reference ("Project");

B. Agency is a Joint Powers Authority providing public transit service for the western portion of Riverside county and is the eligible recipient for the Federal Transit Administration (FTA) Section 5339 Program funds, and State Transit Assistance Funds (STA) and is responsible for the application of these funds and the implementation of the Project.

C. This Project will improve mobility, reduce congestion and Greenhous gas emission and enhance safety for passengers on some of the busiest stops in the Agency's service area.

D. This Agreement defines specific terms, conditions, and funding responsibilities between the City and the Agency for the Project.

E. Upon written approval of Agency, the City shall issue the procurement and award a construction contract or contracts to an experienced contractor or group of contractors for the Project. The City shall act as the Project Manager for the project under the supervision of the Agency and all construction shall meet relevant building codes.

PROJECT DESCRIPTION

This Project will be funded by FTA Section 5339 Program funds, provided by Southern California Association of Governments (SCAG) under Agreement No. M-009-016, and STA funds provided by the State of California (State) and all are subject to the guidelines promulgated by FTA, SCAG, Riverside County Transportation Commission (RCTC) and State. The Project generally consists of construction and construction management of six (6) sawtooth bus bays, six sets of amenities (shelters, benches and trash

Effective: : \$

YTD Available: \$

cans) and six (6) bus pads on Canyon Crest Drive between Blaine and University in Riverside, CA. The Project is more particularly described in Exhibit A attached hereto.

Section I

AGENCY AGREES:

1. To fully fund the construction of the Project in an amount not to exceed One Million One Hundred Fifty Thousand Dollars (\$1,150,000.00) in accordance with the Project Cost Estimate attached hereto as Exhibit "B" and incorporated herein by reference. Agency shall approve final improvement plans and bid documents for the construction of the Project, prior to the City advertising the Project for competitive bids.
2. To participate in the selection of Contractor(s) and to attend all pertinent Project meetings.
3. To agree, at its cost and expense, to promptly defend the City, and the City's employees, officers, managers, agents and council members (collectively the "City Parties to be Defended") from and against any and all claims, allegations, lawsuits, arbitration proceedings, administrative proceedings, regulatory proceedings, or other legal proceedings which arise out of, or relate to, or are in any way connected with: 1) the Services, work, activities, operations, or duties of the Agency, or of anyone employed by or working under the Agency, or 2) any breach of the Agreement by the Agency. This duty to defend shall apply whether or not such claims, allegations, lawsuits or proceedings have merit or are meritless, or which involve claims or allegations that any or all of the City Parties to be Defended were actively, passively, or concurrently negligent, or which otherwise assert that the City Parties to be Defended are responsible, in whole or in part, for any loss, damage or injury. Agency agrees to provide this defense immediately upon written notice from the City, and with well qualified, adequately insured and experienced legal counsel acceptable to City. This obligation to defend as set forth herein is binding on the successors, assigns and heirs of Agency and shall survive the termination of this Agreement.

Further, except as to the sole negligence or willful misconduct of the City, Agency agrees to indemnify, protect and hold harmless the City and the City's employees, officers, managers, agents, and Council Members ("City Indemnified Parties") from and against any claim for damage, charge, lawsuit, action, judicial, administrative, regulatory or arbitration proceeding, damage, cost, expense (including counsel and expert fees), judgment, civil fine and penalties, liabilities or losses of any kind or nature whatsoever whether actual, threatened or alleged, which arise out of, pertain to, or relate to, or are a consequence of, or are attributable to, or are in any manner connected with the performance of this Agreement, or anyone employed by or working under the Agency or for services rendered to Agency in the performance of this Agreement, notwithstanding that the City may have benefited from its work or services. This indemnification provision shall apply to any acts, omissions, negligence, recklessness, or willful misconduct, whether active or passive, on the part of the Agency or anyone employed or working under the Agency.

4. To notify the City in a timely manner, in the event that FTA, SCAG, RCTC or the State of California advises Agency of any restriction on the use of Project Funds that may affect the Project or

provisions of this Agreement, the parties shall meet to discuss any amendments to this Agreement as the parties may deem necessary.

5. To maintain the Project site and related amenities upon completion of the Project by the City and to provide insurance upon completion of construction as follows:
 - a) Commercial Form General Liability Insurance (contractual liability included) with a limit of \$5,000,000 per occurrence, \$10,000,000 aggregate.
 - b) Business Automobile Liability for Owned, Scheduled, Non-Owned or Hired Automobiles with a combined single limit of not less than \$2,000,000 per occurrence, \$4,000,000 aggregate.
 - c) Workers' Compensation as required under California State Law.
 - d) The insurance policies are to contain, or be endorsed to contain, the following provisions:
 - i) **Additional Insured Status.** The City and their officers, officials, employees, and volunteers are to be covered as additional insureds on the CGL policy with respect to liability arising out of work or operations performed by or on behalf of the Agency including materials, parts or equipment furnished in connection with such work or operations. General liability coverage can be provided in the form of an endorsement to Agency's insurance (at least as broad as ISO Form CG 20 10 11 85 or both CG 20 10 and CG 20 37 forms if later revisions used).
 - ii) **Primary Coverage.** For any claims related to this contract, Agency's insurance coverage shall be primary insurance as respects the City and their officers, officials, employees, or volunteers. Any insurance or self-insurance maintained by the City or their officers, officials, employees, agents, consultants or volunteers shall be excess of Agency's insurance and shall not contribute with it.
 - iii) **Notice of Cancellation.** Each insurance policy required above shall state that coverage shall not be canceled, except with notice to the City.
 - iv) **Waiver of Subrogation.** The Agency hereby grants to City a waiver of any right to subrogation which any insurer of said Agency may acquire against the City by virtue of the payment of any loss under such insurance. Agency agrees to obtain any endorsement that may be necessary to affect this waiver of subrogation, but this provision applies regardless of whether or not the City has received a waiver of subrogation endorsement from the insurer.

If the above insurance is written on a claims-made form, it shall continue for three years following termination of this Agreement. The insurance shall have a retroactive date of placement prior to or coinciding with the effective date of this Agreement. It should be expressly understood, however, that the coverage's required under this paragraph 5 shall not in any way limit the liability of the Agency. The coverage referred to under sections a and b of this paragraph 5 shall be endorsed to include City as an Additional Insured. Such a provision, however, shall only apply in proportion to and to the extent of the negligent acts or omissions of the Agency, its officers, agents, or employees. The Agency, upon the completion of construction on Project, shall furnish City with Certificates of Insurance evidencing compliance with all requirements. Certificates shall further provide for thirty (30) days advance written notice.

6. To reimburse the City for all eligible, allowable costs incurred for actual Work performed as more particularly described in accordance with Exhibit A.

7. To provide final approval authority of all invoices and deliverables provided by the City under this Agreement; such approval shall not be unreasonably withheld.
8. To provide notice to the City of all guidelines promulgated by FTA, SCAG, Riverside County Transportation Commission (RCTC) and State that may impact the execution of the Project and ensure the City's compliance with these guidelines and regulations. As the party awarded the STA and FTA Section 5339 Program funds, the Agency is responsible for ensuring compliance with these guidelines and regulations.

Section II

THE CITY AGREES:

1. To lead the Project, complying with all applicable FTA, SCAG, RCTC and State requirements including Agency policies and procedures, and procure an experienced Contractor to construct the Project.
2. To provide the financial commitment, if any is required above the Agency maximum budget set forth above and in Exhibit B, to ensure Project is completed per Exhibit A.
3. To advertise, award and administer a public works construction contract for Project as described in Exhibit A.
4. To furnish Agency with a construction schedule which shall show the dates for major milestones in relation to the Project. Milestone dates should include Contract Award date, Construction start date, Construction completion date and the date the improvements will be available for the Agency's use.
5. To obtain written approval from Agency prior to performing or contracting any work. Any material changes to the contract(s) that affect the scope of work, deliverables, schedule, and/or payment/cost schedule regarding the improvements paid by the Agency (excluding those paid solely by the City) shall also require written approval of Agency. No contract charges impacting the improvements paid by the Agency (excluding those paid solely by the City) shall be reimbursed unless the required written approvals have been obtained from Agency.
6. To lead pertinent meetings regarding the development of Project.
7. To obtain all applicable permits required for the Project.
8. To provide Agency's Project Manager (PM) with copies of all draft and final working documents and project schedules as soon as available; to provide Agency's PM with equal access to all information and materials generated by the City and its contracting entities in the performance of the project.

9. To comply with all conditions and obligations of FTA, SCAG, RCTC and State for the Project, including semi-annual project progress reports and any other information as requested periodically by FTA, SCAG, RCTC and State.
10. Upon completion of the construction of the Project, City shall grant Agency an irrevocable license to use the Project site for the useful life, up to and not to exceed 50 years, of the Project unless mutually terminated by City and the Agency prior to the end of the useful life of the Project. City further agrees to ensure the installed amenities remain on Project site for the useful life of Project and as set forth in this Agreement.
11. If City revokes Agency's license or if the use of the facilities for transit is stopped or obstructed by the City prior to the end of the useful life of the Project as reasonably determined by the parties, the City will pay for removal and relocation of the transit amenities, if applicable, and will reimburse Agency its Project Funds.
12. To agree, at its cost and expense, to promptly defend the Agency, SCAG, and their employees, officers, managers, agents and board members (collectively the "Agency Parties to be Defended") from and against any and all claims, allegations, lawsuits, arbitration proceedings, administrative proceedings, regulatory proceedings, or other legal proceedings which arise out of, or relate to, or are in any way connected with: 1) the Services, work, activities, operations, or duties of the City, or of anyone employed by or working under the City, or 2) any breach of the Agreement by the City. This duty to defend shall apply whether or not such claims, allegations, lawsuits or proceedings have merit or are meritless, or which involve claims or allegations that any or all of the Agency Parties to be Defended were actively, passively, or concurrently negligent, or which otherwise assert that the Agency Parties to be Defended are responsible, in whole or in part, for any loss, damage or injury. City agrees to provide this defense immediately upon written notice from the Agency, and with well qualified, adequately insured and experienced legal counsel acceptable to Agency. This obligation to defend as set forth herein is binding on the successors, assigns and heirs of City and shall survive the termination of this Agreement.

Further, except as to the sole negligence or willful misconduct of the Agency, City agrees to indemnify, protect and hold harmless the Agency, SCAG and their employees, officers, managers, agents, and Board Members ("Agency Indemnified Parties") from and against any claim for damage, charge, lawsuit, action, judicial, administrative, regulatory or arbitration proceeding, damage, cost, expense (including counsel and expert fees), judgment, civil fine and penalties, liabilities or losses of any kind or nature whatsoever whether actual, threatened or alleged, which arise out of, pertain to, or relate to, or are a consequence of, or are attributable to, or are in any manner connected with the performance of this Agreement, or anyone employed by or working under the Agency or for services rendered to City in the performance of this Agreement, notwithstanding that the Agency may have benefited from its work or services. This indemnification provision shall apply to any acts, omissions, negligence, recklessness, or willful misconduct, whether active or passive, on the part of the City or anyone employed or working under the City.

13. To insure its activities in connection with this Agreement and obtain, keep in force, and maintain insurance as follows:

- a) Commercial Form General Liability Insurance (contractual liability included) with a limit of \$5,000,000 per occurrence, \$10,000,000 aggregate.
- b) Business Automobile Liability for Owned, Scheduled, Non-Owned or Hired Automobiles with a combined single limit of not less than \$2,000,000 per occurrence, \$4,000,000 aggregate.
- c) Workers' Compensation as required under California State Law.
- d. The insurance policies are to contain, or be endorsed to contain, the following provisions:
 - i) **Additional Insured Status.** The Agency, SCAG and their officers, officials, employees, and volunteers are to be covered as additional insureds on the CGL policy with respect to liability arising out of work or operations performed by or on behalf of the City including materials, parts or equipment furnished in connection with such work or operations. General liability coverage can be provided in the form of an endorsement to CITY's insurance (at least as broad as ISO Form CG 20 10 11 85 or both CG 20 10 and CG 20 37 forms if later revisions used).
 - ii) **Primary Coverage.** For any claims related to this contract, City's insurance coverage shall be primary insurance as respects the Agency and their officers, officials, employees, or volunteers. Any insurance or self-insurance maintained by the Agency, SCAG or their officers, officials, employees, agents, consultants or volunteers shall be excess of City's insurance and shall not contribute with it.
 - iii) **Notice of Cancellation.** Each insurance policy required above shall state that coverage shall not be canceled, except with notice to the Agency.
 - iv) **Waiver of Subrogation.** The City hereby grants to Agency and SCAG a waiver of any right to subrogation which any insurer of said City may acquire against the Agency by virtue of the payment of any loss under such insurance. City agrees to obtain any endorsement that may be necessary to affect this waiver of subrogation, but this provision applies regardless of whether or not the Agency has received a waiver of subrogation endorsement from the insurer.

If the above insurance is written on a claims-made form, it shall continue for three years following termination of this Agreement. The insurance shall have a retroactive date of placement prior to or coinciding with the effective date of this Agreement. It should be expressly understood, however, that the coverage's required under this paragraph 15 shall not in any way limit the liability of the City. The coverage referred to under sections a and b of this paragraph 15 shall be endorsed to include Agency and SCAG as an Additional Insureds. Such a provision, however, shall only apply in proportion to and to the extent of the negligent acts or omissions of the City, its officers, agents, or employees. The City, upon the execution of this Agreement, shall furnish Agency with Certificates of Insurance evidencing compliance with all requirements. Certificates shall further provide for thirty (30) days advance written notice.

City may meet the requirements of this section through its program of self-insurance at commensurate levels.

- 13. Require City's construction contractor for the Project to obtain, keep in force, and maintain insurance as follows:

- i. Commercial Form General Liability Insurance (contractual liability included) with a limit of \$5,000,000 per occurrence, \$10,000,000 aggregate.
- ii. Business Automobile Liability for Owned, Scheduled, Non-Owned or Hired Automobiles with a combined single limit of not less than \$2,000,000 per occurrence, \$4,000,000 aggregate.
- iii. Workers' Compensation as required under California State Law.

a. The City's construction contractor's insurance policies are to contain, or be endorsed to contain, the following provisions:

- i. **Additional Insured Status.** The City, Agency, SCAG and their officers, officials, employees, and volunteers are to be covered as additional insureds on the CGL policy with respect to liability arising out of work or operations performed by or on behalf of the City including materials, parts or equipment furnished in connection with such work or operations. General liability coverage can be provided in the form of an endorsement to the City's construction contractor's insurance (at least as broad as ISO Form CG 20 IO 11 85 or both CG 20 IO and CG 20 37 forms if later revisions used).
- ii. **Primary Coverage.** For any claims related to this contract, the City's construction contractor's insurance coverage shall be primary insurance as respects the City, Agency, SCAG and their officers, officials, employees, or volunteers. Any insurance or self-insurance maintained by the City and Agency or their officers, officials, employees, agents, consultants or volunteers shall be excess of the City's construction contractor's insurance and shall not contribute with it.
- iii. **Notice of Cancellation.** Each insurance policy required above shall state that coverage shall not be canceled, except with thirty (30) days' prior written notice to the City, Agency and SCAG.
- iv. **Waiver of Subrogation.** The City's construction contractor's policy shall be endorsed to waive any right of subrogation against the City, Agency, SCAG and their subconsultants, employees, officers, agents, and directors for work performed to construct the Project.

b. If the above insurance is written on a claims-made form, it shall continue for three years following the filing of a notice of project completion by the City. The insurance shall have a retroactive date of placement prior to or coinciding with the execution of the construction contract. It should be expressly understood, however, that the coverage's required under this paragraph shall not in any way limit the liability of City's construction contractor. The coverage referred to under sections i and ii of this paragraph shall be endorsed to include Agency and SCAG as an Additional Insureds. Such a provision, however, shall only apply in proportion to and to the extent of the negligent acts or omissions of City, its officers, agents, or employees.

- i. Upon the execution of an agreement with City's construction contractor, shall furnish Agency and SCAG with Certificates of Insurance evidencing compliance with all requirements.

Section III

IT IS MUTUALLY AGREED:

1. The terms of this Agreement shall be from the date of execution by both parties until Project completion or as amended or terminated by either Party.
2. All work under this Agreement shall be coordinated with AGENCY through its Project Manager; for purposes of this Agreement, AGENCY designates the following as its Project Manager:

- i. Kristin Warsinski, Director of Planning
Phone: (951) 565-5136, kwarsinski@riversidetransit.com

For purposes of this Agreement, the City designates the following as its Project Manager:

- ii. Edward Lara, P.E., Principal Engineer
Phone: (951) 826-2337, elara@riversideca.gov

3. AGENCY shall reimburse City for eligible, allowable costs incurred in accordance with this Agreement, including all Exhibits.
4. AGENCY maintains final approval authority of all Invoices and Deliverables provided by the City under this Agreement; such approval shall not be unreasonably withheld.
5. All invoices submitted by the City under this Agreement shall contain information as stated below (see also Exhibit C – Sample Invoice Format):
 - a. No more than monthly, the City shall submit an invoice to Agency, with all supporting documents, by the tenth day of the following month.
 - b. Invoice to include but is not limited to the following information: Name of project, description of services provided, period of the services performed, total cost incurred and percentage of effort completed.
 - c. Upon receipt of itemized invoices submitted in accordance with this Agreement and upon reimbursement by its funding sources, Agency to reimburse the City within thirty (30) days and as its fiscal procedures permit.
 - d. The City to submit a Project Monthly Report (Exhibit D), no later than the tenth day following the end of the previous month. Report can be attached to the invoice or submitted separately. A report must be provided each month regardless of whether there is an invoice to be paid by the Agency.
6. City and Agency shall conduct Project meetings and will establish written protocols for planned and unplanned events that will periodically impact RTA service delivery at bus stops on Canyon Crest Drive.
7. City acknowledges that failure to comply with any material provisions of this Agreement (such failure to comply is hereinafter called a "Default"), including failure to adhere to specified Project milestones of Construction Start Date and Construction End Date may, in the sole but reasonable

discretion of Agency, result in revocation of funding for the Project by Agency. In the event Agency's Chief of Procurement & Logistics Officer determines that the City has committed a Default by failing to comply with a material provision of this Agreement, Agency will notify City in writing of the Default. City shall have thirty (30) days from the date of Agency's Letter of Notification of Default to cure the Default. Subject to the paragraph below, In the event City fails to cure the Default or dispute the Default under this Section within the time allowed in the Letter of Notification of Default, or if City's dispute is not resolved in City's favor, Agency Chief of Procurement & Logistics Officer may revoke the funding for the Project and terminate this Agreement by written notice to City. If the Default is a failure to adhere to one or more specified milestones, City may request an amendment to this Agreement which specifies a revised schedule for attaining the milestone(s). The request for amendment to the Agreement must provide complete justification for the proposed schedule revision. If such an amendment is approved by the Agency's Board of Directors, such amendment shall cure the Default. No alteration or variation of the terms of this Agreement shall be valid unless made in writing and signed by the parties hereto, and no oral understanding or agreement not incorporated herein shall be binding on any of the parties hereto.

Any termination of construction of or operations on the Project site will require FTA approval prior to termination. The party initiating the termination will notify the other party in writing, of the reasons thereof and will be responsible for any penalties imposed by FTA to the extent the termination is not the result of the other party's substantial breach of this Agreement. Agency will notify SCAG in writing the reasons for termination of this Project. Upon termination, all finished and unfinished documents, data, studies, surveys, drawings, maps, models, photographs, reports, or other materials that, if the Agreement had been completed, would be required to be furnished, shall be provided to Agency. City shall be entitled to receive compensation for all satisfactory work completed prior to the effective date of termination. Upon termination of operation or maintenance to the Project, both parties shall identify a mutually preferred site for transit operations, if applicable.

8. Upon completion of all work under this Agreement or termination pursuant to this Section, ownership and title to materials, equipment, structures, and appurtenances, which are installed within City's property, shall automatically be vested in Agency.
9. Nothing in the provisions of this Agreement is intended to create duties or obligations to, or rights in third parties not party to this Agreement, or affect the legal liability of any party to the Agreement by imposing any standard of care, with respect to the maintenance of facilities, different from the standard of care imposed by law.
10. The following exhibits which are attached hereto are incorporated herein and made a part of this Agreement:

Exhibit A-	Design Documents
Exhibit B-	Engineer's Cost Estimate
Exhibit C-	Sample Project Invoice
Exhibit D-	Sample Project Monthly Report

Effective: Duration of project; project

NTE: \$

YTD Available: \$

Exhibit E- FTA Circular 51001. - Bus and Bus Facilities Formula Program; Guidance and Application Instruction

11. All notices, correspondence, and invoices should be sent to the following addresses:

AGENCY	CITY
Send Notices and Correspondence to:	
For Riverside Transit Agency	For CITY
Attn: N. Zaragoza	Attn: Kris Martinez
Chief Procurement and Logistics Officer	Public Works Director
1825 Third Street	3900 Main St., 4th Flr.
Riverside, CA 92507	Riverside, CA 92522
With Additional Copy to:	
Riverside Transit Agency	
Attn: R. Majors	
Risk Manager	
1825 Third Street	
Riverside, CA 92507	
Send Invoices to:	
Riverside Transit Agency	Riverside Transit Agency
Attn: K. Warsinski	Attn: F. Allen
Director of Planning	Accounts Payable
1825 Third Street	1825 Third Street
Riverside, CA 92507	Riverside, CA 92507

12. As this Agreement was jointly prepared by both parties, the language in all parts shall be construed according to its fair meaning and not for or against either party.
13. If any provision of this Agreement is determined to be void by any court of competent jurisdiction, then such determination shall not affect any other provision of this Agreement and all such other provisions shall remain in full force and effect. It is the intention of the parties that if any provision of this Agreement is capable of two constructions, one of which would render the provision void, and the other which would render the provision valid, then the provision shall have the meaning that would render it valid.
14. Each party acknowledges and represents that it has not relied on the promise, statement or representation of the other party or such other party's employees, attorneys or agents that are not contained in this Agreement.
15. For the term of this Agreement, no member, officer or employee of either Party, during the term of his or her service with the City or Agency, shall have any direct interest in this Agreement, or obtain any present or anticipated material benefit arising therefrom. Both Parties covenant that, at present time, it has no interest, and will not have any interest, direct or indirect, which would conflict in any manner with the performance of the Agreement or the Project required hereunder.
16. This Agreement shall be effective on the date first written above and, with the exception of any ongoing obligations set forth in this Agreement, shall remain in effect through June 30, 2022 or through the completion of the Project, whichever first occurs, unless otherwise terminated pursuant to the provisions herein.

This Agreement constitutes the entire understanding of the parties with respect to the subject matter hereof, and there are no other representations, promises, warranties, covenants or undertakings with respect thereto.

[THE REMAINDER OF THIS PAGE IS INTENTIONALLY LEFT BLANK]

IN WITNESS WHEREOF the parties hereto have caused this Agreement to be executed the day and year first above written.

CITY OF RIVERSIDE, a
California charter city and
municipal corporation

RIVERSIDE TRANSIT AGENCY, a joint powers
Agency of the state of California

By: _____
City Manager

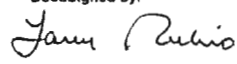
DocuSigned by:

By: _____
0E63E2551A2D48F
Larry Rubio
Chief Executive Officer

Attest:

By: _____
City Clerk

Approved as to form:

By: 
Deputy City Attorney

Approved as to form:

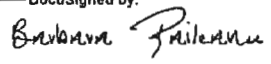
DocuSigned by:

By: _____
A8ABD43006024C1
Barbara Raileanu
General Counsel





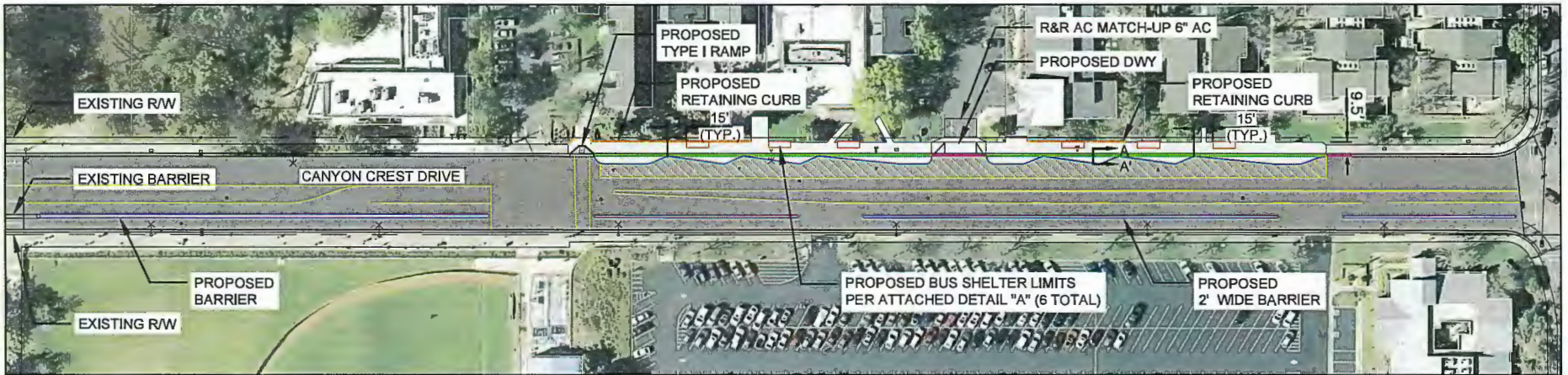



Certified as to the availability of funds:

By: 
Chief Financial Officer

EXHIBIT A - DESIGN DOCUMENTS



LEGEND:

- | | | | |
|-------------------------------------------------------------------------------------|------------------------------------------------|-----------------------------------------------------------------------------------|------------------------------------------------------|
|  | PROPOSED CONCRETE AT BUS BAYS |  | CM3 FULL DEPTH |
|  | PROPOSED PCC |  | PROPOSED AC, CM2, VARIES PER PLAN WITH 0.12' OF ARAM |
|  | PROPOSED 6" CURB AND GUTTER | | |
|  | PROPOSED 12" WIDE TRENCH DRAIN PER SECTION A-A | | |
|  | 6" CURB ONLY | | |
|  | 8" CURB ONLY | | |
|  | RETAINING CURB | | |

YTD Available: \$
NTE: \$
Effective:

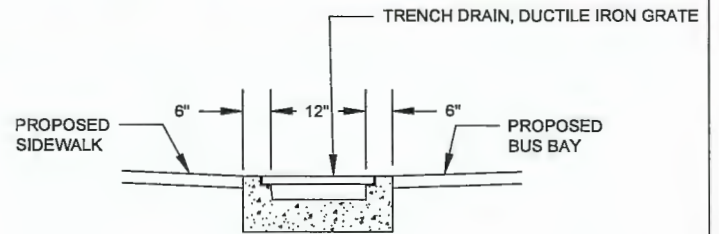
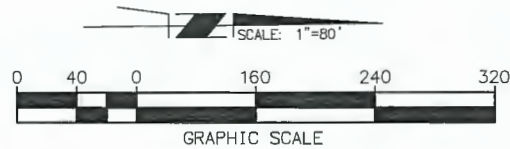

SECTION A-A'
NOT TO SCALE

**CANYON CREST DRIVE
RTA SAWTOOTH BUS STOP EXHIBIT**

GENERAL NOTES:

1. ALL STRUCTURAL STEEL, UNLESS OTHERWISE NOTED, SHALL BE ASTM A-36, MINIMUM YIELD STRENGTH 36,000 PSL.
2. ALL STRUCTURAL ALUMINUM MEMBERS, UNLESS OTHERWISE NOTED, SHALL BE OF ALLOY 6063-T5 OR GREATER.
3. ALL HOLES TO BE DRILLED OR PUNCHED.
4. STEEL WELDING SHALL CONFORM TO AMERICAN WELDING SOCIETY STANDARD D1. 1-10. ELECTRODES SHALL CONFORM TO AWS E-1, CLASS E70-5.
5. ALUMINUM WELDING SHALL CONFORM TO AMERICAN WELDING SOCIETY STANDARD D1. 2-8B. ELECTRODES SHALL CONFORM TO AWS/SPC 5.10 CLASS ER90S.
6. ALL WELDING TO BE DONE AT TOLAR MANUFACTURING COMPANY, INC. FACILITY.

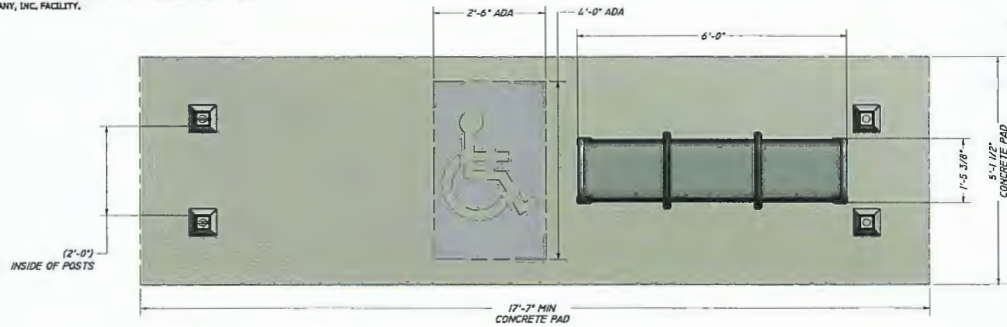

SECTION A-A
SHOWN WITHOUT ESCUTCHEON FOR CLARITY
SCALE 1/16

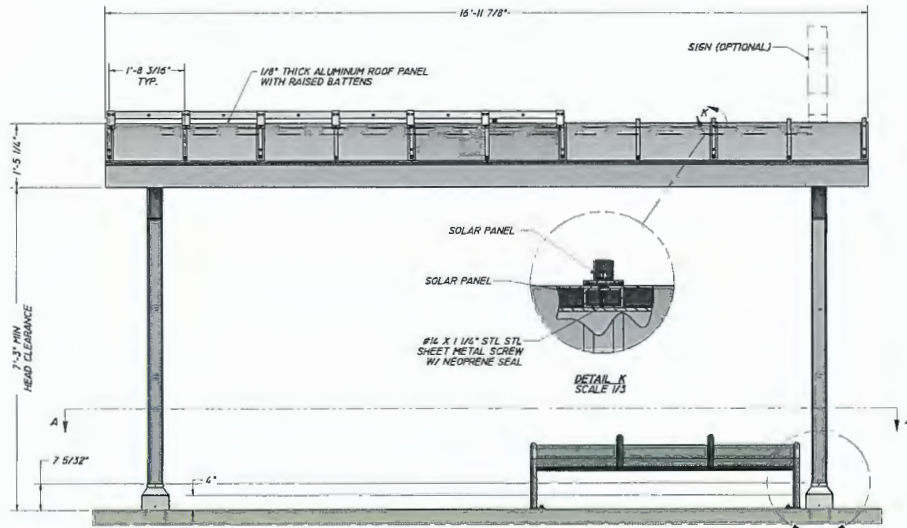

FRONT VIEW

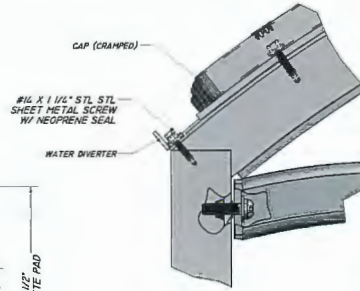

DETAIL H
SCALE 1/2

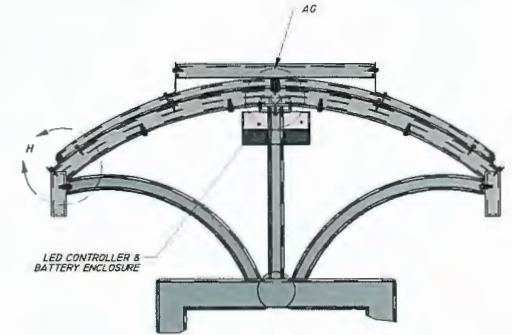

DETAIL D
SCALE 1/8

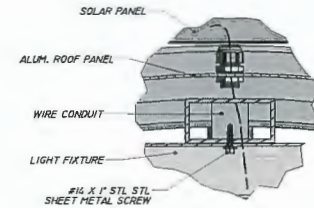

DETAIL AG
SCALE 3/8

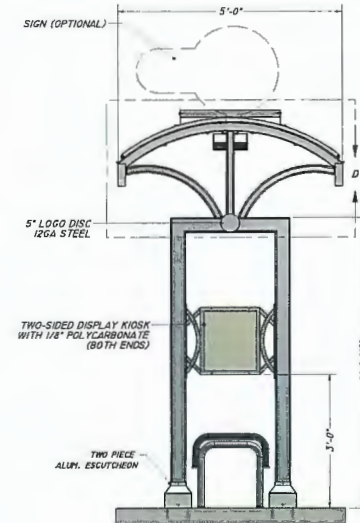

END VIEW

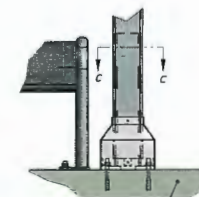

DETAIL B
SHOWN WITHOUT ESCUTCHEON FOR CLARITY
SCALE 1/8

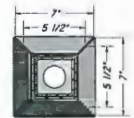

SECTION C-C
SCALE 3/16

NOTE: ALL SHELTER MATERIALS TO BE FURNISHED BY RTA AND INSTALLED BY THE CITY OF RIVERSIDE

CANYON CREST DRIVE
RTA SAWTOOTH BUS STOP EXHIBIT
RTA BUS PAD SHELTER
- DETAIL "A" -

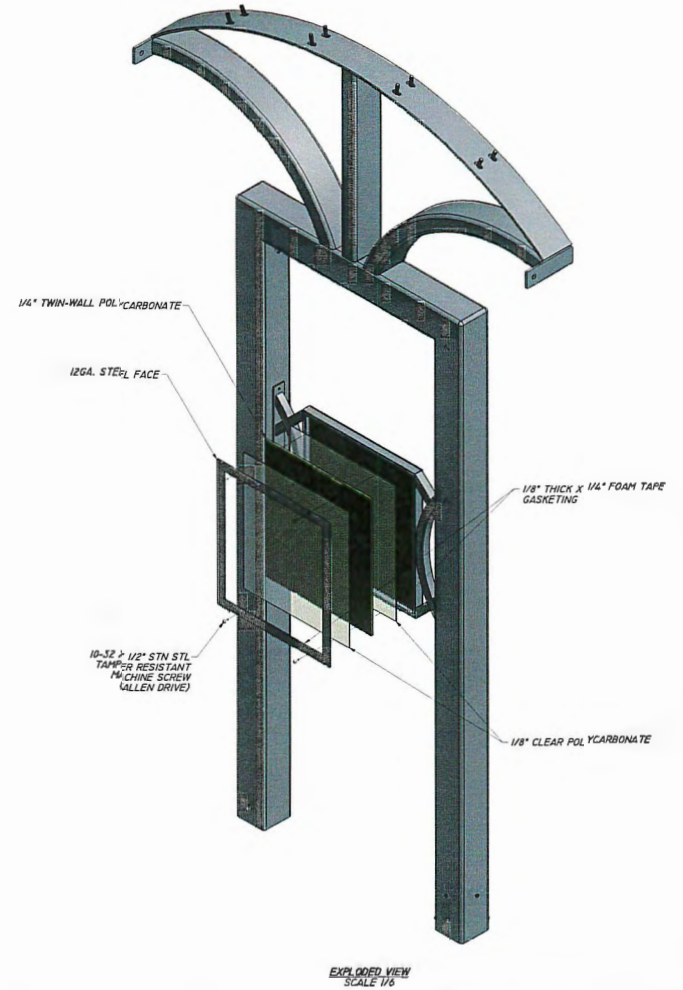
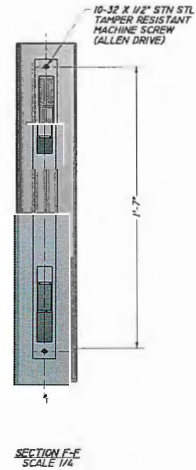
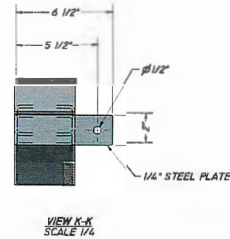
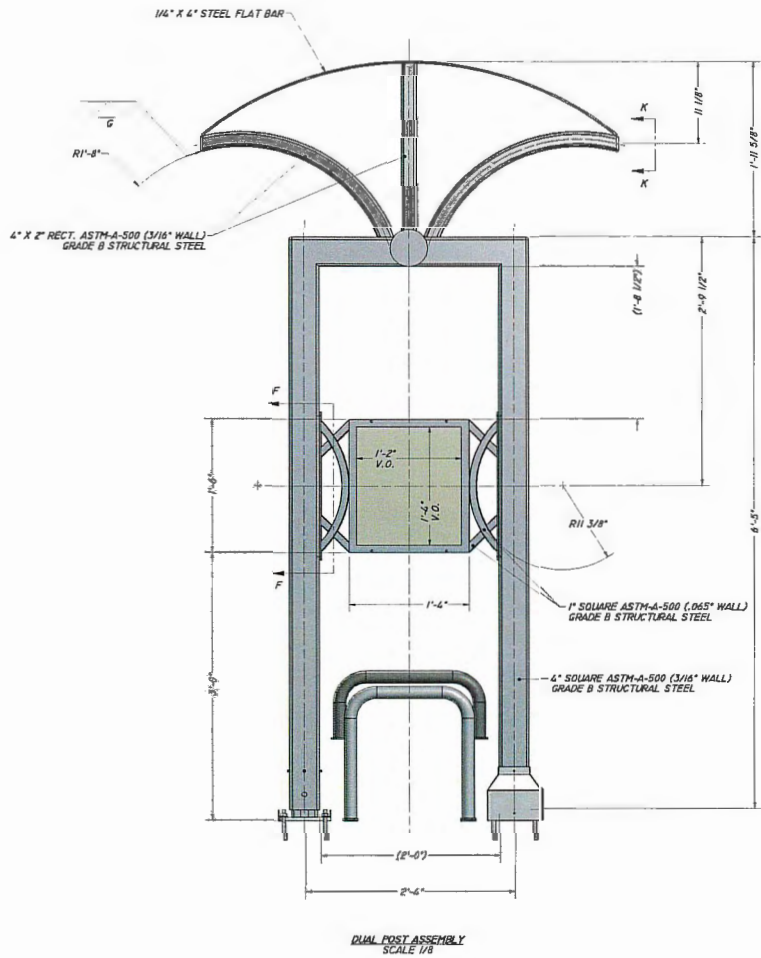

NOTE: ALL SHELTER MATERIALS TO BE FURNISHED BY RTA AND INSTALLED BY THE CITY OF RIVERSIDE

CANYON CREST DRIVE
RTA SAWTOOTH BUS STOP EXHIBIT
RTA BUS PAD SHELTER
- DETAIL "A" -
(Page 2 of 5)

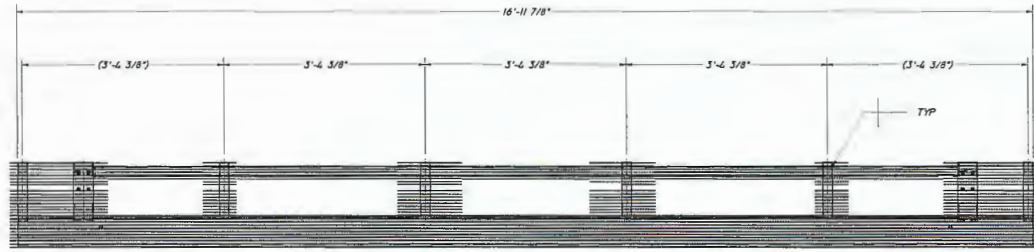

FRONT VIEW
SCALE 1/12

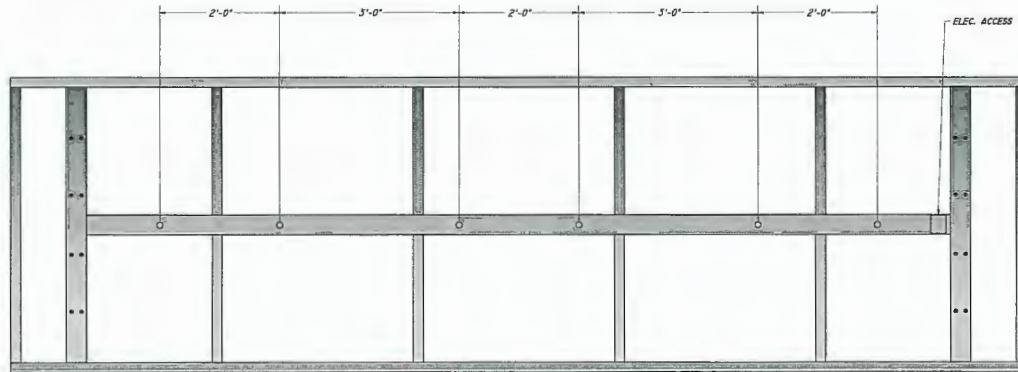

BOTTOM VIEW
SCALE 1/12

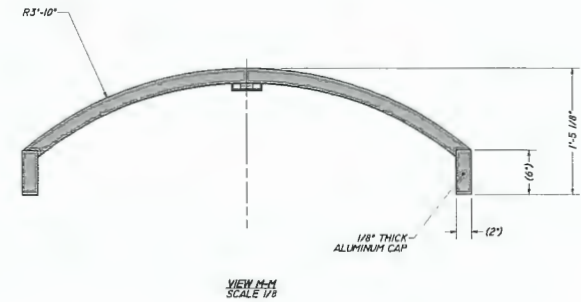
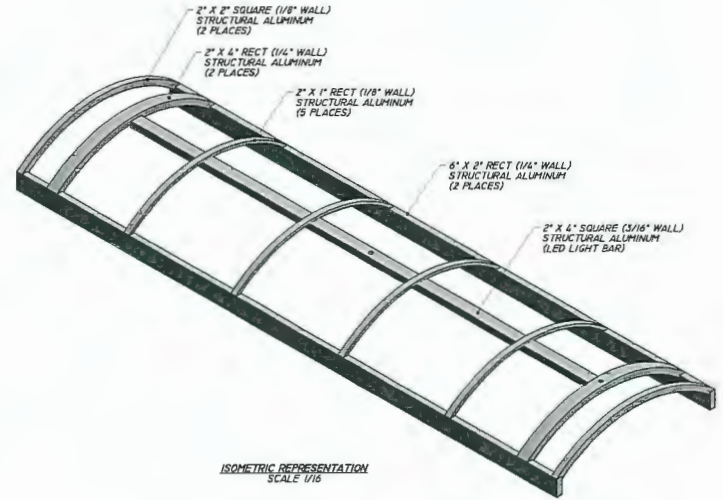

NOTE: ALL SHELTER MATERIALS TO BE FURNISHED BY RTA
AND INSTALLED BY THE CITY OF RIVERSIDE

CANYON CREST DRIVE
RTA SAWTOOTH BUS STOP EXHIBIT
RTA BUS PAD SHELTER
- DETAIL "A" -
(Page 3 of 5)



NOTE: ALL SHELTER MATERIALS TO BE FURNISHED BY RTA
AND INSTALLED BY THE CITY OF RIVERSIDE

CANYON CREST DRIVE
RTA SAWTOOTH BUS STOP EXHIBIT
RTA BUS PAD SHELTER
- DETAIL "A" -
(Page 4 of 5)

Tolar-Corona Shelter 240W Solar Lighting System Wiring Diagram

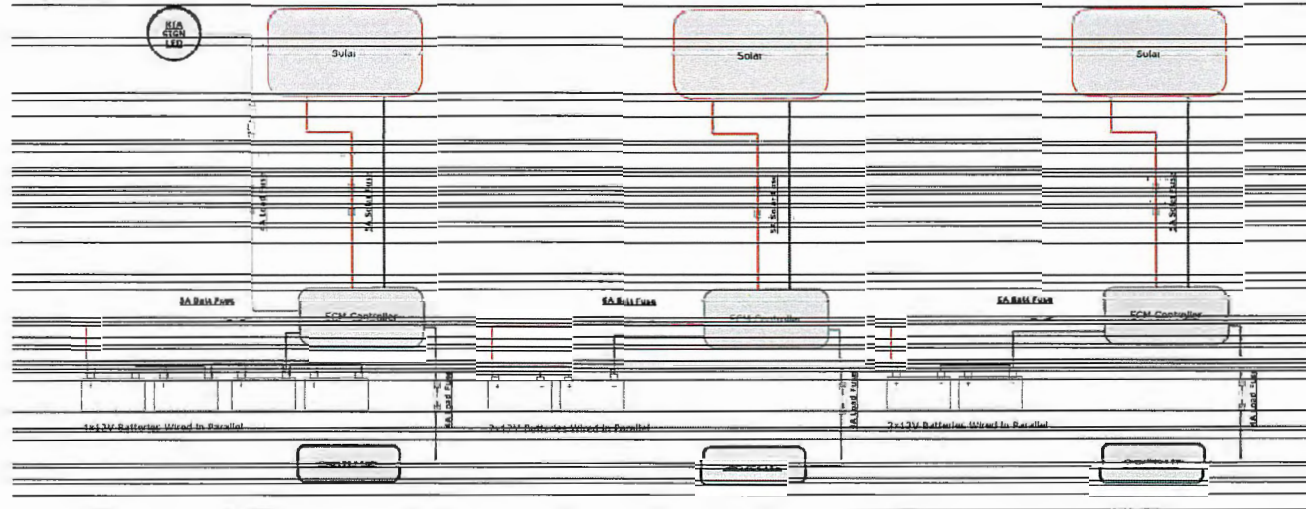

UL LISTED 240W SYSTEM

NOTE: ALL SHELTER MATERIALS TO BE FURNISHED BY RTA
AND INSTALLED BY THE CITY OF RIVERSIDE

CANYON CREST DRIVE
RTA SAWTOOTH BUS STOP EXHIBIT
RTA BUS PAD SHELTER
- DETAIL "A" -
(Page 5 of 5)

EXHIBIT B - ENGINEER'S ESTIMATE

ENGINEER'S ESTIMATE					
RTA Sawtooth Bus Stop Improvements on Canyon Crest Drive					
Amount rounded to Nearest: \$.01					
No.	CONTRACT BID ITEMS	Quantity	Unit	Unit Price	Total
Incidentals					
1	Note: All items subject to any special notes or footnotes appearing on this Engineer's estimate included with the bid documents.
2	Note: The Contract lump sum or unit price for each Contract Bid Item shall include full compensation for all labor, materials, tools, taxes, profit, overhead, incidentals and appurtenant work necessary for performing and completing the work of the Contract Bid Item as required by the Project Plans, Specifications, Special Provisions and other Contract Documents. Such compensation shall also include or take into consideration any additional provisions or conditions specifically stated immediately following the Contract Bid Item.
3	Note: In the absence of a specific bid item or specific payment provisions for any portion of the work required by the Contract Documents, the bidder shall include the bidder's compensation for that portion of the Contract work in the Contract unit price(s) and/or lump sum price(s) of the bid item(s) that require such work, or are closely related to such work. Therefore, no separate or additional payment will be made to the Contractor for any such work on the premise that such work lacks specific bid item(s) or specific payment provisions.
4	Note: "(P)" adjacent to a Contract bid item designates a "Partial Pay Item" per Section 9-3.2 of the Special Provisions.
5	Note: "(F)" adjacent to a Contract bid item designates a Final Pay Quantity per Section 9-3.2.1 of the Special Provisions.
6	Note: "(S)" adjacent to a Contract bid item designates a "Specialty Item" per Section 2-3.2 of the Special Provisions.
7	Mobilization, (P)	1	LS	\$25,000.00	\$25,000.00
8	Water Pollution Control, (P)	1	LS	\$5,000.00	\$5,000.00
9	Traffic Control and Access, (P). (Includes all requirements indicated in Section 7-10-1.1 of the Special Provisions which is not included in any other specific bid item.)	1	LS	\$15,000.00	\$15,000.00
Sub-Total: Incidentals Items					\$45,000.00
Street Improvements					
10	Unclassified Excavation (F)	750	CY	\$50.00	\$37,500.00
11	Cold Milling, Type CM2 (Depth Varies Per Plan) (Includes variable grind when indicated)	58,000	SF	\$0.50	\$29,000.00
12	Asphalt Pavement - DGAC (Includes all new paving and resurfacing paving as indicated.)	520	TON	\$140.00	\$72,800.00
13	Crack Fill and Crack Repair (per linear foot of street centerline)	1,190	LF	\$2.00	\$2,380.00
14	Construct Asphalt Rubber Aggregate Membrane (ARAM), (S)	58,000	SF	\$0.50	\$29,000.00
15	Concrete Curb and Gutter per City Std 200. (Type per plan, Curb and Gutter dimensions to match existing or as indicated for new, including any modifications indicated on plans.)	65	LF	\$75.00	\$4,875.00
16	Concrete 6" Curb per City Std 200. (Type per plan, Curb dimensions to match existing or as indicated for new, including any modifications indicated on plans.)	560	LF	\$50.00	\$28,000.00
17	Concrete 8" Curb Only per City Std 200. (Type per plan, Curb dimensions to match existing or as indicated for new, including any modifications indicated on plans.)	1,990	LF	\$60.00	\$119,400.00
18	12" Wide Trench Drain	540	LF	\$150.00	\$81,000.00
19	Concrete Bus Pad per Detail in Special Provisions (Includes relocation of bus stop sign with new footing)	7,900	SF	\$35.00	\$276,500.00
20	Concrete Driveway per City Std 302. (Includes all modifications as indicated. Includes PCC retaining curb adjacent to driveways and driveway matchups when required)	540	SF	\$20.00	\$10,800.00
21	PCC Pedestrian Ramp per City Std 304. (Type per plan and includes any modifications.)	1	EA	\$5,000.00	\$5,000.00
22	PCC Sidewalk per City Std 325 (Includes parkway slope grading in conformance with the plans and the Standard 325. Includes furnishing and installing traffic rated boxes and lids when indicated)	7,700	SF	\$15.00	\$115,500.00
23	PCC Retaining Curb - Includes heights up to 18 inches	210	LF	\$35.00	\$7,350.00
24	Install RTA Bus Stop Equipment - Includes obtaining RTA furnished material from RTA.	6	EA	\$1,000.00	\$6,000.00
25	Removal of Unsuitable AC, Base, and/or Subgrade Material (Includes locations not indicated on the plans, at the direction of the engineer.)	400	CY	\$50.00	\$20,000.00
26	Replacement Base for Unsuitable AC, Base, and/or Subgrade Material (Includes locations not indicated on the plans, at the direction of the engineer.)	400	CY	\$50.00	\$20,000.00
27	Replacement DGAC for Unsuitable AC, Base, and/or Subgrade Material (Includes locations not indicated on the plans, at the direction of the engineer.)	200	TON	\$150.00	\$30,000.00
28	Adjust Manhole to Grade (Includes Sewer, Water, and Storm Drain, Communication manhole covers)	5	EA	\$800.00	\$4,000.00
29	Adjust Gate Valve, ETS Gas Valve, or Cleanout Cover to Grade (Includes cleaning and painting all facilities and installing city furnished material as specified.)	8	EA	\$600.00	\$4,800.00
30	Construct Drain Pipe - Core new curb and install 3" PVC SDR-35 drain pipe. Connect new pipe to existing pipe	4	EA	\$500.00	\$2,000.00
31	Remove Class I Tree and Roots	2	EA	\$1,500.00	\$3,000.00
32	Remove Class II Tree and Roots	4	EA	\$2,000.00	\$8,000.00
33	Remove Class III Tree and Roots	2	EA	\$3,000.00	\$6,000.00
Sub-Total: Street Improvements					\$922,905.00

ENGINEER'S ESTIMATE					
RTA Sawtooth Bus Stop Improvements on Canyon Crest Drive					
Amount rounded to Nearest: \$.01					
No.	CONTRACT BID ITEMS	Quantity	Unit	Unit Price	Total
Traffic Improvements					
34	4" Dashed White Stripe (Thermo) - Detail 9 w/ RPMs, (S)	450	LF	\$0.40	\$180.00
35	Double Yellow Median Island (Thermo) - Detail 29 w/ RPMs, (S)	720	LF	\$5.00	\$3,600.00
36	Two-Way Left Turn Stripe (Thermo) - Detail 32 w/ RPMs, (S)	1,600	LF	\$3.25	\$5,200.00
37	8" Solid White Stripe (Thermo) - Detail 38A, (S)	600	LF	\$2.50	\$1,500.00
38	6" Dashed White Stripe (Thermo) - Detail 39A, (S)	360	LF	\$0.75	\$270.00
39	12" Solid Stripe (Thermo), (S)	300	LF	\$3.75	\$1,125.00
40	Pavement Markings (Thermo), (S)	1,000	SF	\$3.75	\$3,750.00
41	Paint Curb (RED)	800	LF	\$3.25	\$2,600.00
42	Relocate Sign (Single Post Req'd), (S)	6	EA	\$80.00	\$480.00
43	Install Sign (Single Post Req'd), (S)	6	EA	\$200.00	\$1,200.00
44	Type "D" Detector Loop, (S)	3	EA	\$400.00	\$1,200.00
45	Type "E" Detector Loop, (S)	6	EA	\$300.00	\$1,800.00
46	Type "C" Detector Loop, (S)	4	EA	\$400.00	\$1,600.00
47	Bicycle Indications at Traffic Signals	2	EA	\$1,500.00	\$3,000.00
48	Traffic Signal Controller Replacement for modified operations	1	EA	\$2,700.00	\$2,700.00
49	Splice new to existing conductors, (S)	13	EA	\$200.00	\$2,600.00
Sub-Total: Traffic Improvements					\$32,805.00
TOTAL FOR ALL CONTRACT BID ITEMS					\$1,000,710.00
				10% CONTIGENCY	\$100,071.00
				DESIGN & SURVEY ENGINEERING	\$24,219.00
				CONSTRUCTION ADMIN	\$15,000.00
				CONSTRUCTION ENGINEERING	\$10,000.00
TOTAL:					\$1,150,000.00

INVOICE COPY

City of Riverside
Finance Division
3900 Main St.
Riverside, CA 92522



Customer # C023331
Invoice # 00000000
Invoice Date 00/00/00

Phone: (951) 826-5311
Contact ID:

Payment Due Date 00/00/00

Billed To: RTA
1825 THIRD ST
P O BOX 59968
RIVERSIDE CA 92507

Total Amount Due \$ xxx,xxx.xx

Code	Description	Date	Amount
PW	RTA/City Canyon Crest Funding Agmt <i>Grant Number CA-34-0030</i>	00/00/2021	xxx,xxx.xx

Invoice Balance \$ xxx,xxx.xx

Customer # C023331 **Invoice #** 00000000 **Invoice Date** 00/00/00

Mail payment to:
City of Riverside
Treasury Division
3900 Main St.
Riverside, CA 92522

To pay by Credit Card:	Charge Amount: \$ _____
<input type="checkbox"/> Visa <input type="checkbox"/> Mastercard <input type="checkbox"/> American Express <input type="checkbox"/> DiscoverCard	
Credit Card #	_____
Expiration:	_____ Signature: _____
<i>Credit card payments cannot be processed without the cardholder's signature.</i>	

Due Date 00/00/21

Amount Due \$ xxx,xxx.xx

Amount Enclosed:
\$ _____

To ensure proper credit, please return this payment stub with your payment.

Invoice Detail
 RTA/City Canyon Crest CA-34-0030
 Bus Stops & Shelters Project

00/00/21

Description	Current Costs	Previously Paid	Current Due
Invoice #1			
City Staff Time			0.00
Fringe Benefits			0.00
Contractor Payments			0.00
Other Invoices			0.00
Total	0.00	0.00	0.00
Total to Date			0.00
Agreement Amount			1,150,000.00
Previously Paid			0.00
Amount Due this Invoice			0.00
Balance			1,150,000.00

EXHIBIT D-SAMPLE PROJECT MONTHLY REPORT

SECTION 5339 MONTHLY REPORT			
Sub-Recipient Name:	Riverside Transit Agency		
Contact Name:	Kristin Warsinski	Phone No./Email:	951-565-5136 kwarsinski@riversidetransit.com
Project Title:	RTA Bus Stops & Shelters Project		
Grant Number:	CA-34-0030		
Report Period Start Date:		Report Period End Date:	

PROJECT STATUS OVERVIEW					
Total Funds:		Total Expenditures During Quarter:		Cumulative Expenditures:	
Remaining Balance:					

PROJECT LINE ITEM SUMMARY AND MILESTONES		
Project Quarterly Summary: Provide update on work done during the reporting period.		
Overall Percentage Complete:		
Activity Number and Title Milestone Description	Estimated (MM/DD/YY)	Actual Completion (MM/DD/YY)
1. RFP/IFB Issued		
2. Contract Award		
3. Contract Complete		

 Approved by: Signature

 Report prepared by: Signature

 Name, Title, Agency

 Name, Title, Agency

 Date

 Date

EXHIBIT E

FTA Circular 51001. - Bus and Bus Facilities Formula Program; Guidance and Application Instruction

https://www.transit.dot.gov/sites/fta.dot.gov/files/docs/Final_FTA_C_5100_4-16-15_1.pdf