

APPENDIX A

Scoping Agreement

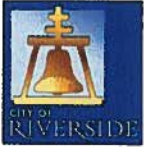

SCOPING AGREEMENT FOR TRAFFIC IMPACT STUDY

This letter acknowledges the City of Riverside Public Works Traffic Engineering Division requirements for traffic impact analysis of the following project. The analysis must follow the City Traffic Study Guide dated December 2014.

Case No. _____
 Related Cases – _____
 SP No. SP-001-923 (Sycamore Canyon Business Park Specific Plan)
 EIR No. _____
 GPA No. _____
 CZ No. _____
 Project Name: Sycamore Canyon Business Park Buildings 1 & 2
 Project Address: North of Sierra Ridge, West of Lance Drive
 Project Description: Light Industrial buildings (Building 1: 1,012,995 sq ft, Building 2: 420,604 sq ft)

	<u>Consultant</u>	<u>Developer</u>
Name	<u>Albert A. Webb Associates</u>	<u>HPA, Inc. – Jocelyn Wan</u>
Address	<u>3788 McCray Street</u> <u>Riverside, CA 92506</u>	<u>18831 Bardeen Avenue, Suite 100</u> <u>Irvine, CA 92612</u>
Telephone:	<u>(951) 686-1070 Fax: (951) 788-1256</u>	<u>(949) 862-2125</u>

A. Trip Generation Source: ITE 9th Edition

Existing Land Use	<u>Vacant</u>	Proposed Land Use	<u>Industrial</u>
Existing Zoning	<u>BMP</u>	Proposed Zoning	<u>BMP</u>
Total Daily Trips	<u>3,608</u>		

	<u>In</u>	<u>Out</u>	<u>Total</u>
AM Trips	<u>155</u>	<u>67</u>	<u>223</u>
PM Trips	<u>82</u>	<u>179</u>	<u>260</u>

Internal Trip Allowance Yes No (0% Trip Discount)
 Pass-By Trip Allowance Yes No (0% Trip Discount)
 (Attach additional sheet if this is a multi-use site with a breakdown of trips generated)

B. Trip Geographic Distribution: N 0% S 0% E 0% W 0%
(See attached figure for detailed assignment)

C. Background Traffic

Project Completion Year: 2018 Annual Ambient Growth Rate: 2%
 Other area projects to be included: P07-1181/P07-0593, P08-0274/P09-0275, P10-0090/P10-0091, P10-0557/P10-0559, P12-0419/P12-0557/P12-0558/P12-0559, P14-0457, P14-0536/P14-0537, P07-1073, P07-1028/P06-0416/P06-0418/P06-0419/P06-0421/P07-0102, P13-0665, P14-1053/P14-0154, P13-0553/P13-0554/P13-0583/P14-0065, P14-0600/P14-0601/P14-0602/P15-0044, P12-0309, P12-0507/P12-0508/P12-0509/P12-0510, P13-0607/P13-0608/P13-0609/P13-0854, P14-0246, and cumulative projects from the City of Moreno Valley.
 Model/Forecast methodology if required Build-out modelling not required.

D. Study Intersections: (NOTE: Subject to revision after other projects, trip generation and distribution are determined, or comments from other agencies.)

- | | |
|---|--|
| 1. <u>I-215 NB Ramps/Box Springs Rd</u> | 2. <u>Sycamore Canyon Rd/Box Springs Rd</u> |
| 3. <u>I-215 SB Ramps/Sycamore Canyon Rd</u> | 4. <u>Sycamore Canyon Rd/Dan Kipper Dr</u> |
| 5. <u>Sycamore Canyon Rd/Box Springs Blvd</u> | 6. <u>Sycamore Canyon Rd/Sierra Ridge Dr</u> |
| 7. <u>Sycamore Canyon Rd/Eastridge Ave</u> | 8. <u>Box Springs Blvd/Eastridge Ave</u> |
| 9. <u>I-215 Ramps/Eastridge Ave</u> | 10. _____ |

E. Study Roadway Segments (For GP level study):

- | | |
|----------|----------|
| 1. _____ | 2. _____ |
| 3. _____ | 4. _____ |
| 5. _____ | 6. _____ |
| 7. _____ | 8. _____ |

F. Other Jurisdictional Impacts:

Is this project within any other Agency's Sphere of influence or one-mile radius of boundaries? Yes No

If so, name of City Jurisdiction: Moreno Valley, Caltrans

G. Site Plan (please attach a legible 11"x17" copy)

H. Specific issues to be addressed in the Study (In addition to the standard analysis described in the Guideline) (To be filled out by Public Works Traffic Department)

INCLUDE ANALYSIS OF PASSENGER VEH. EGRESS @ DAN KIPPER
ASSESS TURNING PATHS & GEOMETRY @ ACCESS/DWY (INCLUDE TRUCKS)
AND ANY POTENTIAL RESTRICTIONS AS SHOWN IN SCOPE TRIP DISTRIBUTION

Recommended by:



Consultant's Representative

August 25, 2015
Date

Scoping Agreement Submitted on

June 12, 2015
Date

Scoping Agreement Resubmitted on

August 25, 2015
Date

Approved Scoping Agreement:



City of Riverside
Traffic Engineering Division

8/31/15
Date

cc: Planning Division
Land Development Section

Table 1: Project Trip Generation Rates

Land Use	Unit	AM Peak Hour			PM Peak Hour			Daily
		Total	In	Out	Total	In	Out	
High-Cube Warehouse Land Use Category: 152	TSF							
<i>Passenger Cars</i>		0.080	0.055	0.025	0.080	0.025	0.055	1.040
<i>Trucks (2 Axle)</i>		0.005	0.004	0.004	0.007	0.002	0.002	0.108
<i>Trucks (3 Axle)</i>		0.007	0.005	0.005	0.009	0.003	0.003	0.145
<i>Trucks (4+ Axle)</i>		0.018	0.013	0.013	0.024	0.007	0.007	0.386
LAND USE TOTAL		0.110	0.076	0.034	0.120	0.037	0.083	1.680

TSF = 1,000 Square Feet Gross Floor Area.

Average trip generation rates from *Trip Generation Manual, ITE, 9th Edition (2012)*.

2 axle / 3 axle / 4+ axle truck split from *Truck Trip Generation Study by the City of Fontana, 2003*.

Table 2: Project Trip Generation

Land Use	Qty	Unit	AM Peak Hour			PM Peak Hour			Daily
			Total	In	Out	Total	In	Out	
High-Cube Warehouse (Building 1)	1013	TSF							
<i>Passenger Cars</i>			81	56	25	81	25	56	1,054
<i>Trucks (2 Axle)</i>			5	3	2	7	2	5	110
<i>Trucks (3 Axle)</i>			7	5	2	9	3	6	147
<i>Trucks (4+ Axle)</i>			18	13	5	25	8	17	391
LAND USE TOTAL			111	77	34	122	38	84	1,702
High-Cube Warehouse (Building 2)	420.6	TSF							
<i>Passenger Cars</i>			33	23	10	33	11	22	438
<i>Trucks (2 Axle)</i>			2	2	1	3	1	2	46
<i>Trucks (3 Axle)</i>			3	2	1	4	1	3	61
<i>Trucks (4+ Axle)</i>			8	5	2	10	3	7	162
LAND USE TOTAL			46	32	14	50	16	34	707
PROJECT TOTAL			157	109	48	172	54	118	2,409

TSF = 1,000 Square Feet Gross Floor Area.

Table 3: Project Trip Generation (in PCE)

Land Use	Qty	Unit	AM Peak Hour			PM Peak Hour			Daily
			Total	In	Out	Total	In	Out	
High-Cube Warehouse (Building 1)	1013	TSF							
<i>Passenger Cars (PCE = 1.0)</i>			81	56	25	81	25	56	1,054
<i>Trucks (2 Axle, PCE = 1.5)</i>			8	5	3	11	3	8	165
<i>Trucks (3 Axle, PCE = 2.0)</i>			14	10	4	18	6	12	294
<i>Trucks (4+ Axle, PCE = 3.0)</i>			54	39	15	75	24	51	1,173
LAND USE TOTAL (IN PCE)			157	110	47	185	58	127	2,686
High-Cube Warehouse (Building 2)	420.6	TSF							
<i>Passenger Cars (PCE = 1.0)</i>			33	23	10	33	11	22	438
<i>Trucks (2 Axle, PCE = 1.5)</i>			3	3	2	5	2	3	69
<i>Trucks (3 Axle, PCE = 2.0)</i>			6	4	2	8	2	6	122
<i>Trucks (4+ Axle, PCE = 3.0)</i>			24	15	6	30	9	21	486
LAND USE TOTAL (IN PCE)			66	45	20	76	24	52	1,115
PROJECT TOTAL (IN PCE)			223	155	67	260	82	179	3,801

PCE = Passenger Car Equivalent for Trucks

Figure 1: Project Trip Distribution (Passenger Vehicles – Outbound)

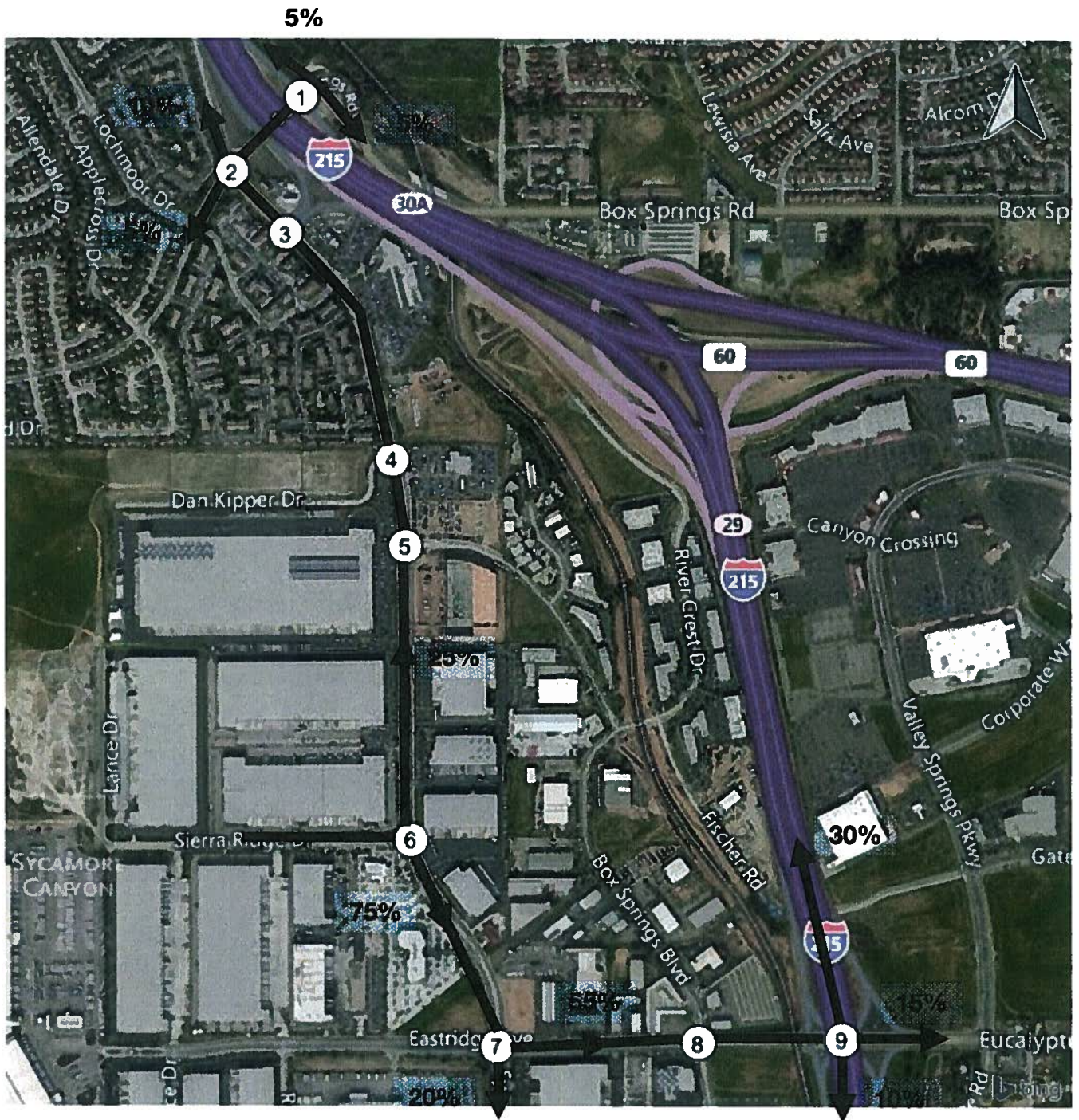

Figure 2: Project Trip Distribution (Passenger Vehicles – Inbound)

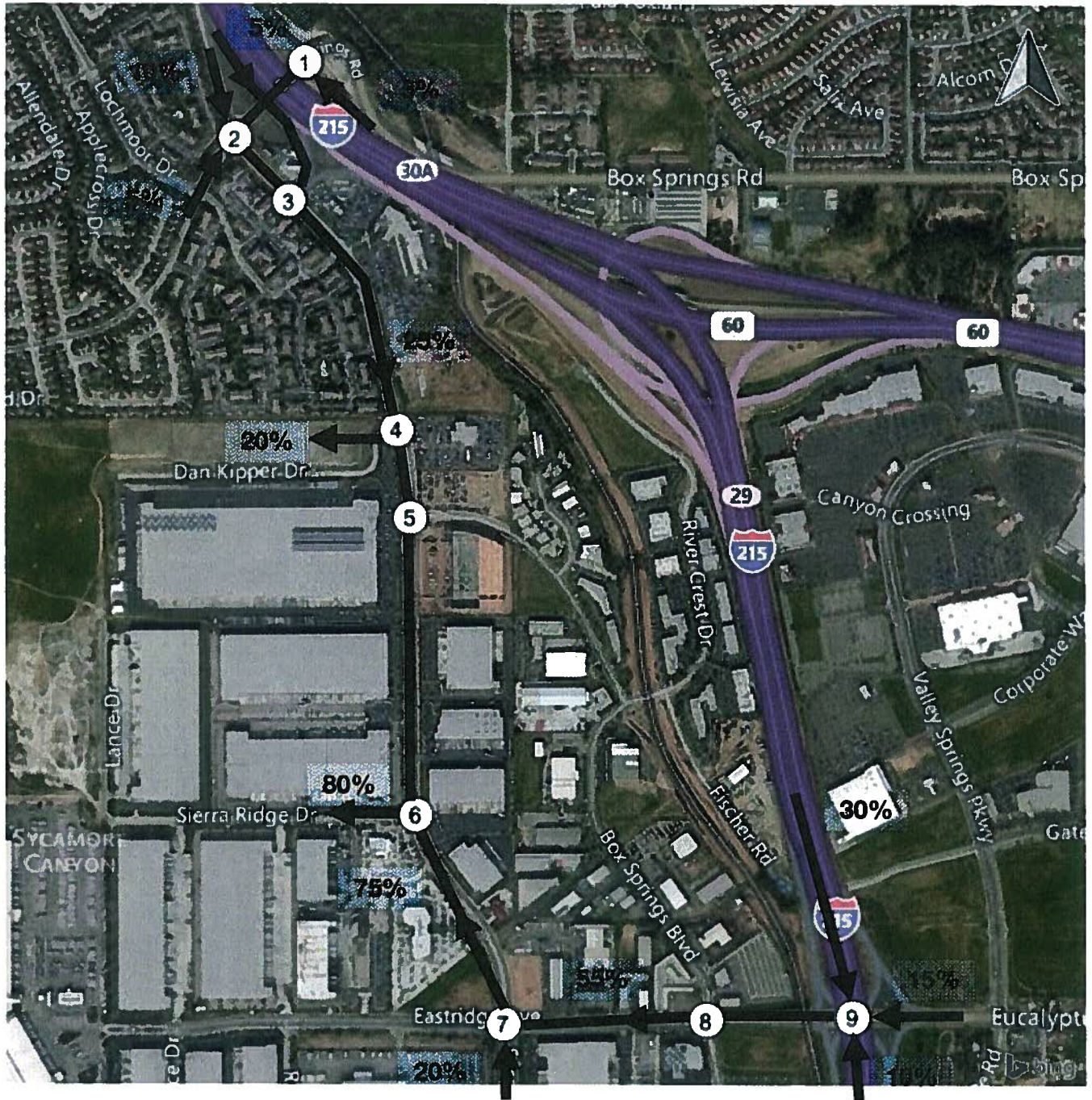

Figure 3: Project Trip Distribution (Trucks – Outbound)

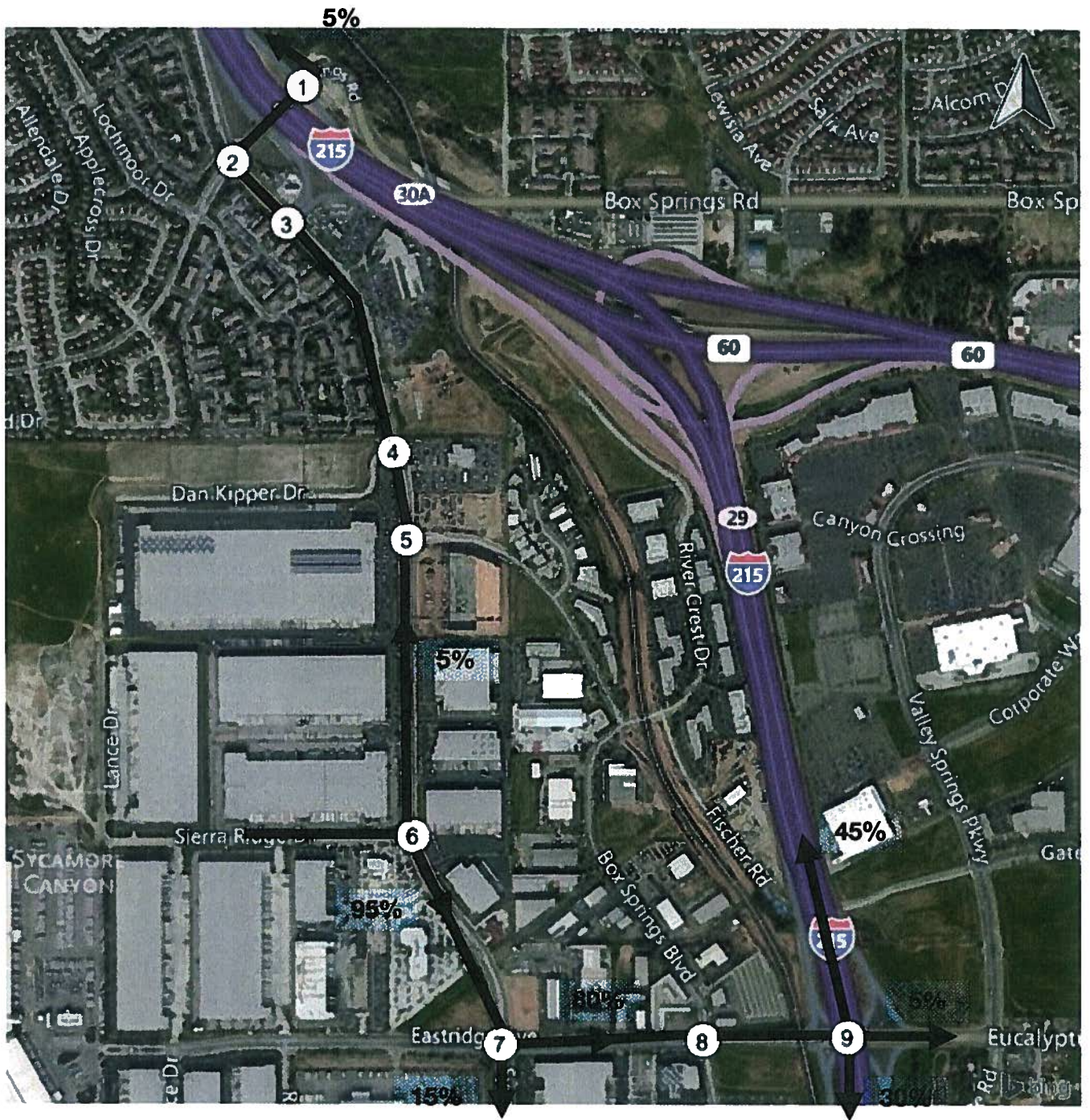
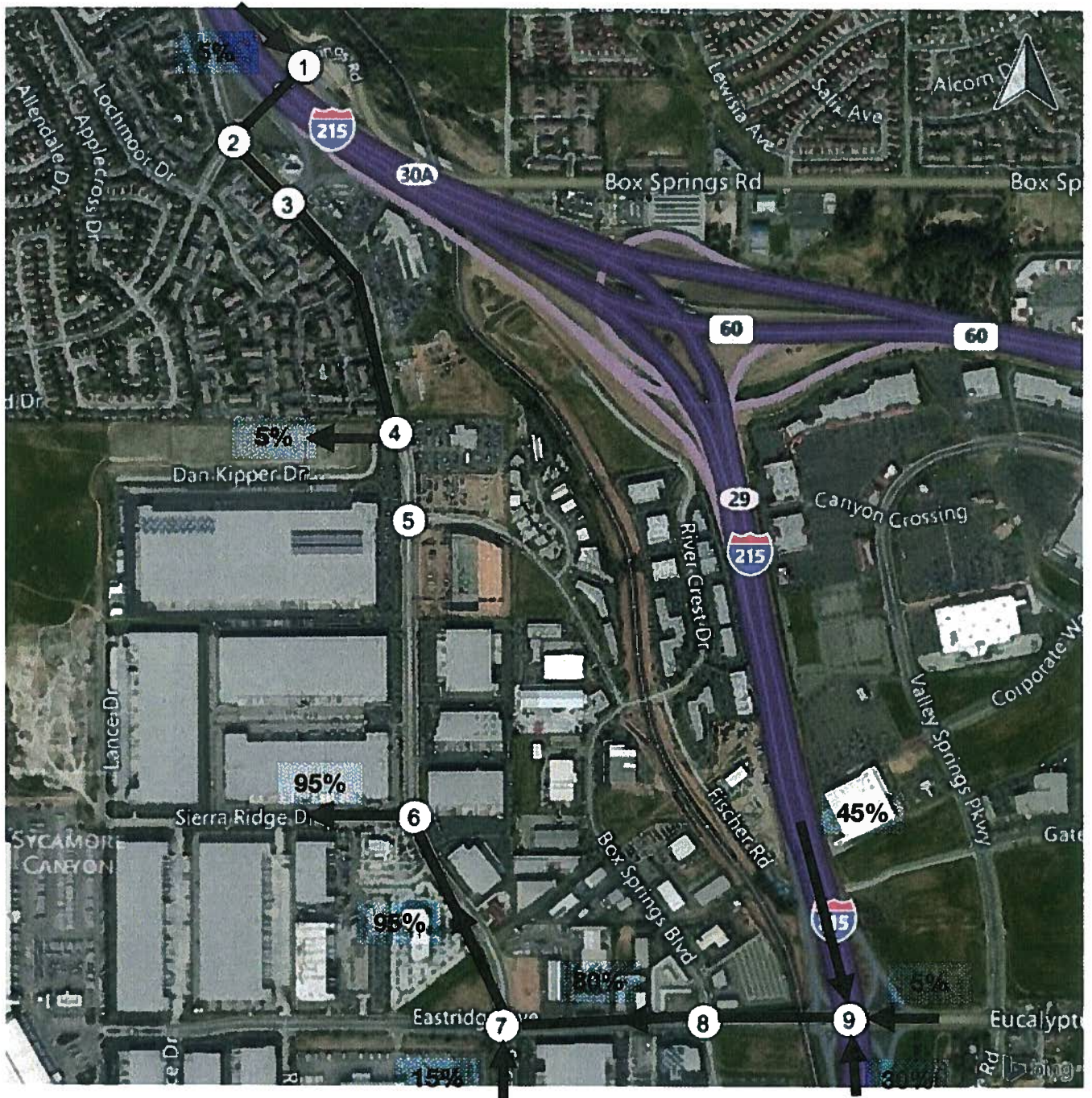
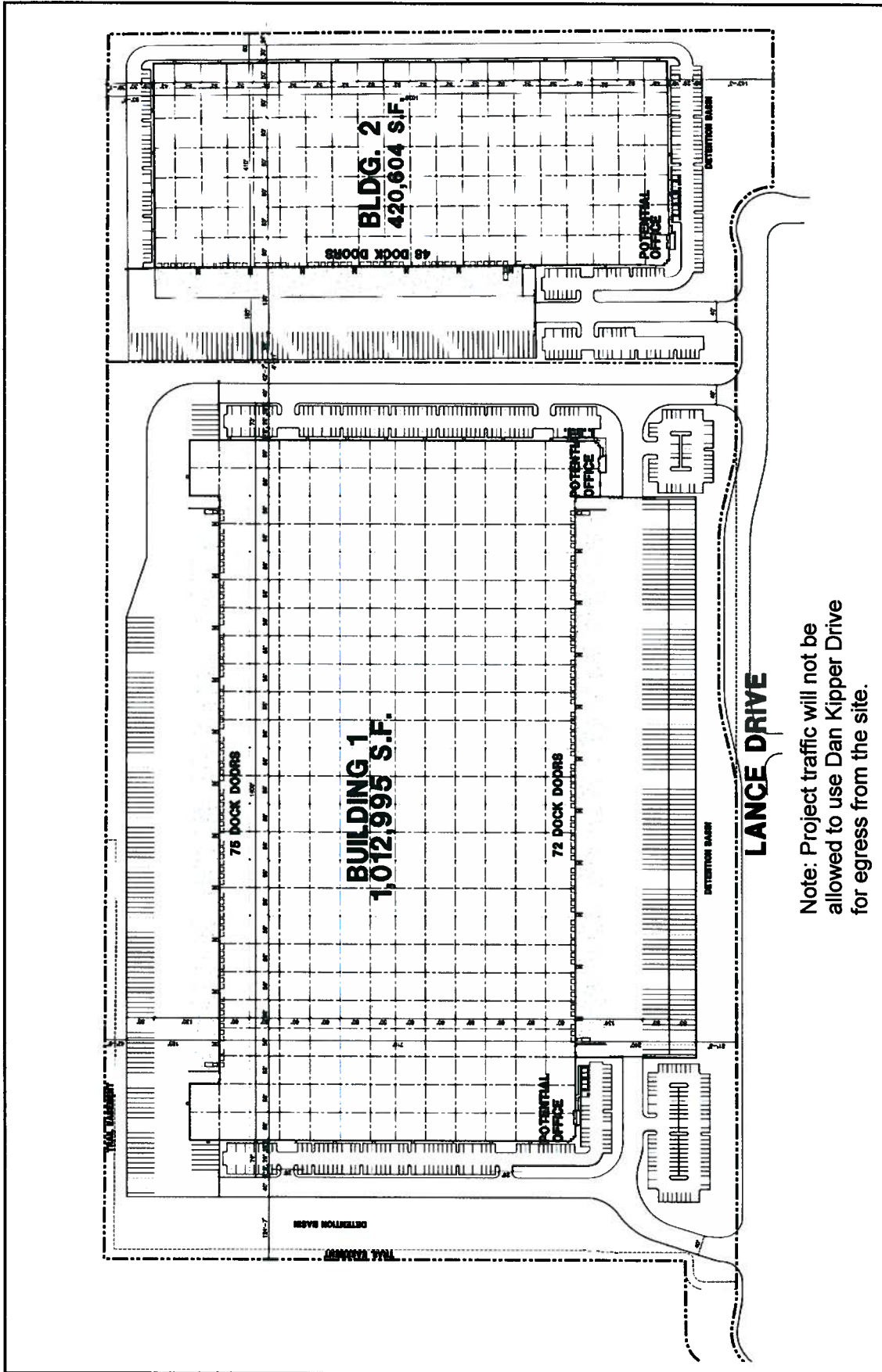

Figure 4: Project Trip Distribution (Trucks – Inbound)





Note: Project traffic will not be allowed to use Dan Kipper Drive for egress from the site.

Source: HPA Architecture, July 2015.



Not to Scale

Figure 3 - Proposed Site Plan
Sycamore Canyon Business Park Buildings 1 and 2



Grace Cheng

From: Grace Cheng
Sent: Friday, July 10, 2015 11:25 AM
To: 'Roberts, Mark B@DOT'
Subject: RE: Acceptable Levels of Service at I-215 Freeway Ramps - City of Riverside

Hi Mark,

Thanks for the quick reply. We will include the merge/diverge analysis for Box Springs & Eucalyptus. The project won't be sending any trips to Alessandro so that ramp wouldn't need to be included in the analysis. For the ambient growth rate, we'll take a look at the RivTAM model which is based on the SCAG model, since that is what the Riverside County uses for their modelling. I'll get back to you on what that turns out to be. Thanks.



Grace Lin Cheng, MS | MCP | PE - Associate Engineer
Albert A. Webb Associates
3788 McCray Street, Riverside, CA 92506
t: 951.320.6038
e: grace.cheng@webbassociates.com w: www.webbassociates.com
[LinkedIn](#) | [Twitter](#) | [Facebook](#) | [YouTube](#)

From: Roberts, Mark B@DOT [<mailto:mark.roberts@dot.ca.gov>]
Sent: Thursday, July 09, 2015 9:28 AM
To: Grace Cheng
Subject: RE: Acceptable Levels of Service at I-215 Freeway Ramps - City of Riverside

Hello

I concur with the intersections to be studied.

Our Traffic Operations Division will also likely ask for a merge/diverge analysis for the affected Freeway ramps (Box Springs, Eucalyptus and Allesandro).

Related to the use of 2% growth rate assumption I'd prefer you use the 2012 SCAG RTP Model or other model based on the SCAG Model (if 2% is what you derive from the SCAG Model) then I concur as well.

Caltrans
District 8 (San Bernardino and Riverside Counties)
Mark Roberts
Office of Intergovernmental Review, Community and Regional Planning
Senior Transportation Planner, AICP
464 West 4th Street, 6th Floor, MS 725
San Bernardino, CA 92401-1400

(909) 383-4557

From: Grace Cheng [<mailto:grace.cheng@webbassociates.com>]
Sent: Wednesday, July 08, 2015 11:54 AM
To: Roberts, Mark B@DOT
Subject: Acceptable Levels of Service at I-215 Freeway Ramps - City of Riverside

Hi Mark,
Attached is a preliminary scoping agreement for a proposed project in the City of Riverside, located in the Sycamore Canyon Business Park area. As a part of the traffic study, we will be studying the I-215 freeway ramps at Fair Isle/Box Springs and Eucalyptus. Please review the scoping agreement and provide any comments you may have. Would these intersections be evaluated under a required level of service of D?
Thanks.



Grace Lin Cheng, MS | MCP | PE - Associate Engineer
Albert A. Webb Associates
3788 McCray Street, Riverside, CA 92506
t: 951.320.6038
e: grace.cheng@webbassociates.com w: www.webbassociates.com
[LinkedIn](#) | [Twitter](#) | [Facebook](#) | [YouTube](#)

[Join our mailing list!](#)

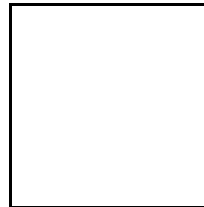

[Protection Notice](#)

Click [here](#) to report this email as spam.

APPENDIX B

Cumulative Project Information

Conditional Use Permits

Map ID #	Case Number	Location	Project Description	Acres	Buildings Total Square Feet	Dwelling Units	Approval Date	Include?
C1	P07-1161	2111 Iowa St	Conditional use permit to establish an indoor rock climbing facility in an existing industrial building	2.80	5,580	-	CC 1/15/08	Too far
C2	P07-1181 P07-0593	381 Alessandro Blvd	Revised Conditional Use Permit, Design Review for Auto Parts Store	1.17	1,500	-	CC 5/6/08	x
C3	P06-0028 P06-0029 P06-0031	3520 Market St	CUP/DR/TM34945; Fox Plaza Mixed Use Development, Up to 205 Condos, restaurant, retail space, 125 unit Hyatt Place Hotel	1.90	31,600	205	CC 6/10/08	Too far
C4	P08-0201 P08-0202	1054 N. Orange St	Conditional use permit and design review of plot plan for Senior Apartment Complex	0.77	-	23	CC 6/17/08	Too far
C5	P08-0274 P08-0275	2570 Canyon Springs Pkwy	Conditional Use Permit, Design Review for Commercial Bank w/Drive-thru	0.14	2,746	-	CC 9/9/08	x
C6	P08-0407	19743 Luren Ave	Conditional use permit to allow the construction of a children's daycare center	3.85	10,000	-	CC 11/4/08	Too far
C7	P08-0491 P08-0948	1690 Spruce St	Conditional Use Permit to allow entertainment within an existing 7,004 square foot building located in the Business Manufacturing Park in the Hunter Business Park Specific Plan	-	7,004 (existing bldg)	-	CC 2/17/09	Too far
C8	P08-0980 P09-0095	3549 Iowa Ave	Revised Conditional Use Permit to allow double-bedroom occupancy and to increase the number of student beds from 760 up to 874 at an existing student housing establishment	11.70	-	-	CC 4/28/09	Too far
C9	P08-0960 P09-0025	1360 University Ave	Revised Conditional Use Permit, Design Review to convert existing ground floor retail space into 8 new student housing units (24 bedrooms), allow double-bedroom occupancy, and increase the number of overall student beds from 528 up to 635 beds	5.00	11,459	8	CC 5/12/09	Too far
C10	P09-0147	7840 Indiana Ave	Conditional use permit; Car & tire sales, auto body repair & painting	0.86	12,510 (existing bldg)	-	CC 6/9/09	Too far
C11	P09-0142	NE corner of Jurupa and Payton Aves	Conditional Use Permit to allow for the development of a surface vehicular storage lot	4.22	-	-	CC 6/23/09	Too far
C12	P09-0125	3500 Iowa Ave	Revised Conditional Use Permit to allow double-bedroom occupancy and to increase the number of student beds from 525 to 548 in existing student housing	1.70	-	-	CC 7/28/09	Too far
C13	P09-0185	7590-94 Indiana Ave	Conditional use permit; Drive-thru restaurant	0.90	280 (existing bldg)	-	CC 8/11/09	Too far
C14	P09-0207 P09-0209 P09-0210	2624 E. Alessandro Blvd	CUP, PM36205, DR Arco Car Wash	1.88	42 ft. long wash tunnel with 100 ft stacking lane	-	CC 10/20/09	Built
C15	P09-0612	1737 Atlanta Ave	Conditional Use Permit to establish an adult day care/work skills learning facility for up to 39 developmentally disabled adults	7.60	3,900 (lease space in existing 41,000 sq.ft. building)	-	CC 12/15/09	Too far
C16	P08-0301	6115 Arlington Ave	Conditional use permit; Harvest Christian Fellowship; 450-stall parking Lot	5.38	-	-	ZA 1/27/10	Too far
C17	P09-0530 P09-0531	1821 – 1855 Third St	Conditional Use Permit, Design Review for the temporary storage of buses for RTA	2.60	-	-	CC 2/2/10	Too far
C18	P09-0582 P09-0583	150 Palmyrita Ave	Conditional Use Permit, Design Review for the establishment of a Sandals Church within an existing building	7.50	95,654 (existing bldg)	-	CC 1/5/10	Too far

Conditional Use Permits

Map ID #	Case Number	Location	Project Description	Acres	Buildings Total Square Feet	Dwelling Units	Approval Date	Include?
C19	P09-0717 P09-0718	807 Blaine St	Site Plan Review; Apartment complex	2.00	5,490	55	CC 4/6/10	Too far
C20	P09-0808 P08-0809	2340 Fourteenth St	Conditional Use Permit to allow the development of a 4-story, 134 bed senior housing complex	2.87	101,974 (existing bldg)	121	CC 6/14/11	Too far
C21	P09-0811	7170-72 Indiana Ave	Conditional use permit; Veterinary clinic	0.45	4,402	-	CC 5/4/10	Too far
C22	P09-0835 P10-0002	3372 University Av	Conditional Use Permit and Certificate of Appropriateness to allow the establishment of an approximately 94-foot tall, 6-story office building with a four-story subterranean parking structure containing 453 parking spaces in the Downtown Specific Plan-Raincross District	0.82	132,136	-	CC 4/27/10	Too far
C23	P10-0083	10938 Magnolia Ave	Conditional Use Permit, Initial Study; Walgreens	2.92	14,064	-	CC 7/13/10	Too far
C24	P10-0090 P10-0091	6287 Day St	Conditional Use Permit, Design Review; Arco, new Gas Canopy and repainting of building fueling station and add 2 additional multi-product fuel pumps	0.91	2,700	-	CC 6/8/10	x
C25	P10-0095 P10-0168 P10-0171	3050 Chicago Ave	Conditional Use Permit, Rezoning, Design Review for charter school for approximately 250 students from grades K-8; Rezone from BMP to O	1.85	15,685	-	CC 7/27/10	Too far
C26	P12-0248	7500 Jurupa Ave	Time extension of conditional use permit (P10-0128) to establish a building materials supply store with wholesale ancillary retail sales within a previously approved 36,822 square foot industrial building	6.59	36,822	-	ZA 5/25/12	Too far
C27	P10-0366 P10-0368	3501 Adams St	Rezoning property from Office to Commercial Retail; Conditional Use Permit to allow Check Cashing facility	0.50	3,176 (lease space in existing bldg)	-	CC 7/13/10	Too far
C28	P10-0219	4183 Fairgrounds St	Conditional use permit; establish a church with 180 fixed seats within an existing 10,312 square foot industrial building	0.81	10,312 (existing bldg)	-	CC 7/13/10	Too far
C29	P10-0259 P10-0270	6686 Indiana Ave	Conditional Use Permit, Design Review; Baker's drive-thru restaurant	0.65	2,234	-	CC 7/27/10	Too far
C30	P10-0380	1820 - 1860 University Ave	Conditional Use Permit allow the establishment of a vocational school for approximately 150 students within an existing 29,870 square foot building in the University Avenue Specific Plan	3.31	29,870	-	CC 10/12/10	Too far
C31	P10-0511	4500 Riverwalk Pkwy	Conditional Use Permit; La Sierra University School of Business building	30.44	68,573	-	ZA 11/1/10	Too far
C32	P10-0557 P10-0559	6365 Valley Springs Pkwy	Conditional Use Permit, Design Review for construction of Navy Federal Credit Union	1.68	3,500	-	CC 1/11/11	Built
C33	P09-0731 P10-0567 P10-0568	1715 – 1745 University Ave	Amendment to the University Avenue Specific Plan to allow drive-thrus in conjunction with retail pharmacies in Subarea 1; CUP/DR for a Walgreens.	0.8	15,004	-	CC 2/8/11	Too far
C34	P10-0506 P10-0507 P10-0508 P10-0509	3020 Iowa Ave; northeast corner of Iowa Ave and Blaine St	Conditional Use Permit, Rezoning, Lot Line Consolidation, Variance; student housing project with 216 one, two and four bedroom units with a total of 614 beds within three four-story buildings; Rezone from R-1-7000 to R-3-1500	8.10	-	216	CC 2/22/11	Too far
C35	P10-0733	2059 Atlanta Ave	Conditional Use Permit to establish a church with 598 fixed seats within an existing building	3.52	52,000 (existing bldg)	-	CC 3/8/11	Too far

Conditional Use Permits

Map ID #	Case Number	Location	Project Description	Acres	Buildings Total Square Feet	Dwelling Units	Approval Date	Include?
C36	P09-0419 P10-0476	2278 Main St	Conditional Use Permit, Design Review; Redesign of site with a Gas Station & Car Wash; Request includes off sale of beer & wine	0.77	3,100	-	CC 3/8/11	Too far
C37	P10-0715	7701 Indiana Ave	Conditional use permit; Vehicle repair facility	0.70	4,085	-	CC 4/5/11	Too far
C38	P11-0014 P11-0015	8432 Magnolia Ave	Conditional use permit and design review for California Baptist University to facilitate the construction of a 42 1/2 foot tall, 2-story building (School of Business) in the Magnolia Ave Specific Plan	1.24	56,717	-	CC 4/26/11	Too far
C39	P10-0685 P10-0794	1855 Columbia Ave	Conditional Use Permit, Design Review for an automated vehicle wash facility, new fuel pump, overhead canopy structure and façade improvements to an existing convenience store	0.63	1,014	-	CC 5/24/11	Too far
C40	P10-0707 P10-0708	North side Van Buren Blvd, 200 ft West of Wood St	Conditional Use Permit, Design Review for construction of Baker's Drive-Thru	1.17	2,361	-	CC 5/24/11	Too far
C41	P11-0018	8537 Magnolia Ave	Conditional Use Permit to convert an existing independent senior housing complex to an assisted living facility for seniors within Magnolia Avenue Specific Plan	2.36	-	98	CC 6/14/11	Too far
C42	P11-0087 P11-0088	3520 Adams St	Conditional Use Permit and Design Review for California Baptist University to facilitate the first phase renovation of the existing Adams (Lancer) Plaza for the construction of 2-story, 48 foot tall Student Recreation Center toward the rear (west) portion of the complex in the Magnolia Avenue Specific Plan	7.24	62,463	-	CC 6/14/11	Too far
C43	P11-0131 P11-0132	8432 Magnolia Ave	Conditional use permit and Certificate of Appropriateness for California Baptist University to construct a single-story building for expansion of the existing Central Energy Plant and relocation of the CBU Ceramics and Sculpture Studio in the Magnolia Avenue Specific Plan; project is in close proximity to historic James Complex and Harden Square	-	5,745	-	CC 7/12/11	Too far
C44	P11-0192 P11-0196	3747 Monroe Ave	Conditional use permit and Certificate of Appropriateness for California Baptist University to construct a new 317-space parking lot and associated improvements. In addition, design improvement to the Hawthorne House and the surrounding landscape. Project site is located in the Magnolia Avenue Specific Plan Overlay Zones	4.02	-	-	CC 8/9/11	Too far
C45	P11-0082	711 N. Main St	Conditional Use Permit to legalize an existing vehicle impound yard and offices on a site developed with two single-story office buildings and a predominantly unpaved surface parking lot	0.99	7,737 (existing bldgs)	-	CC 10/18/11	Too far
C46	P11-0545	1540 Linden St	Conditional use permit to allow the establishment of a church with 80 fixed seats within an existing building	0.64	11,346 (existing bldg)	-	CC 11/1/11	Too far

Conditional Use Permits

Map ID #	Case Number	Location	Project Description	Acres	Buildings Total Square Feet	Dwelling Units	Approval Date	Include?
C47	P11-0460	1044 East La Cadena Dr	Conditional use permit to legalize and expand an adult day care/work skills learning facility for up to 90 developmentally disable adults and 30 staff members within an existing building	1.20	8,562 (existing bldg)	-	CC 12/6/11	Too far
C48	P11-0623 P11-0713	10121 Hole Ave	Conditional use permit to convert existing retail space into new fitness facility in the Magnolia Avenue Specific Plan	1.45	15,362	-	CC 2/7/12	Too far
C49	P12-0234	3439 Arlington Ave	Design Review; LA Fitness ~9,600 square foot expansion to an existing ~42,000 square foot health and fitness club	5.50	~51,6000	-	ZA 05/31/12	Too far
C50	P12-0019 P12-0156 P12-0158	NW cor Riverwalk Parkway and Flat Rock Dr	Conditional Use Permit, Specific Plan Amendment, and Design Review of plot plan and building elevations to facilitate the construction of a vehicle fuel station and wash facility as a 2,400 square foot convenience store and a 3,946 square foot coffee shop in the Commercial Retail La Sierra University Specific Plan Overlay Zone	1.17	6,346	-	CC 9/4/12	Too far
C51	P10-0438	3875 Dawes St	DR; Magnolia Garden Condominiums	3.61	-	62	ZA 9/21/12	Too far
C52	P12-0266 P12-0267 P12-0268	5938 - 5944 Grand Ave	Conditional Use Permit and Design Review for a 2-story senior housing facility with associated parking, on two vacant parcels approximately 1.4 acres	1.40	-	37	CC 10/9/12	Too far
C53	P12-0351	3550 Vine St	Conditional Use Permit to allow the establishment of a vocational/technical school for a maximum of 252 students at any one time within an existing 40,060 square foot 3-story office building in the Marketplace Specific Plan	2.60	10,000 of 2nd floor of existing bldg	-	CC 10/9/12	Too far
C54	P11-0627 P11-0628 P11-0777 P11-0778	4901 La Sierra Ave	CUP, DR, LL, RZ; Service Station and Convenience Store at 5-Points	1.01	4,100	-	CC 10/9/12	Too far
C55	P12-0360	2100 Alessandro Blvd	Conditional Use Permit to establish a vocational school on a site currently developed with an approximately 11,505 square foot single-story retail building in the Sycamore Canyon Business Park Specific Plan	2.15	11,505 (existing bldg)	-	CPC 12/6/12	Built
C56	P11-0329 P11-0330 P11-0332	1101-1163 Marlborough Ave and 3960 11th St	Conditional use permit, variance and design review for a new passenger train station platform and parking lot for Metrolink Service expansion along with existing SBJL right of way. This is within the Business Manufacturing Park (1101-1163 Marlborough Ave) and Downtown Specific Plan Almond Street District (3960 11th St)	9.56	-	-	CC 12/11/12	Too far
C57	P12-0520 P12-0524	3580 Adams St	Conditional use permit; California Baptist University student services complex; rehabilitate existing retail space		36,266	-	CC 1/8/13	Too far
C58	P12-0605 P12-0606	4250 Van Buren Blvd	Conditional Use Permit and Design Review, to allow the expansion of a vehicle fuel station consisting of construction of second set of pumps and 1,776 sq.ft. canopy at existing "Food 4 Less" supermarket	7.45	-	-	CC 4/9/13	Too far

Map ID #	Case Number	Location	Project Description	Acres	Buildings Total Square Feet	Dwelling Units	Approval Date	Include?
C59	P12-0419 P12-0557 P12-0558 P12-0559	360 Alessandro Blvd	Conditional Use Permit and Design Review to allow the establishment of a stand-alone financial institution; General Plan Amendment to change property from MDR to C; Rezoning from Residential Estate to Office	0.84	3,858	-	CC 5/7/13	x
C60	P12-0761 P12-0442 P12-0443 P12-0444	2831 Mary St	Conditional Use Permit to allow the development of a CVS drug store that coincides with Stater Bros redevelopment project (Conditional Use Permit, Rezoning, and Design Review)	6.30	56,101	-	CC 5/14/13	Too far
C61	P12-0742	6825 - 6900 Jurupa Ave	Conditional Use Permit; Riverside Auto Auction; Vehicle Storage Yard, Minor Vehicle repair and inspections within an existing office/industrial building where the outdoor storage of wholesale vehicles has been previously approved (P10-0282, CC Approved 10/19/10)	27.71	56,000 (existing bldg)	-	CC 6/11/13	Too far
C62	P13-0060	5160 Arlington Ave	Conditional Use Permit request on behalf of Chase Bank to allow an existing one drive-thru lane on an existing 4576.87 square foot building to be demolished and reconstructed to include a two lane 36-foot drive thru lane for business purposes	6.26	4,576.87 (existing bldg)	-	CC 6/25/13	Too far
C63	P13-0087 P13-0262	2450 Market St	CUP/DR; Conditional Use Permit to allow the reuse of a Senior assisted living facility to allow it to become a low-income single family apartment complex in the Downtown Specific Plan-Market Street Gateway District	1.42	Existing 16,730 sq.ft.complex	77	CPC 8/8/13	Too far
C64	P13-0432	6091 Victoria Ave	Conditional Use Permit to construct and operate a day care center at a church facility in a residential & cultural resources zone	3.40	1,831 (existing bldg)	-	CC 9/24/13	Too far
C65	P13-0470	8223 California Ave	Conditional Use Permit to re-establish a church and private school; originally approved in 1950s and revised in 1981	5.20	-	-	CC 11/5/13	Too far
C66	P13-0159 P13-0160	6692 Indiana Ave	CUP, DR; Proposal to construct new 7-Eleven vehicle fuel station to operate 24 hours within a commercial retail zone	0.75	2,958	-	CC 12/3/13	Too far
C67	P13-0181 P13-0182	4824 Jones Ave	CUP, DR; Requesting the expansion of an existing building with 23,124 square foot building for an assembly of people within the Rural Residential zone.	6.14	Existing 33,542 square feet, proposed expansion 23,124 square feet	-	CC 12/17/13	Too far
C68	P10-0212 P10-0213	2069 Massachusetts Ave	CUP, DR; Proposal to legalize a bus storage yard for 180 school buses	4.38	-	-	CC 12/17/13	Too far
C69	P13-0650 P13-0651	2586 University Ave	MCUP and Certificate of Appropriateness; Proposal to convert an existing 2500 sqft 2-story residence to a bed and breakfast with an 1118 sqft addition	0.23	3,650	-	ZA 12/19/13; CHB 12/18/13	Too far
C70	P08-0402 P13-0822	18580 Van Buren Blvd	Conditional use permit to allow the construction of a one-story minor automobile repair shop; Modification of conditions to extend hours	0.93	8,142	-	Original CUP - CC 11/4/08; Modifications of conditions - CC 1/7/14	Too far
C71	P13-0785 P13-0787	4247 Van Buren Blvd	CUP, DR; Expansion of existing church	3.43	12,166	-	CC 2/25/14	Too far
C72	P13-0989	1200 Columbia Ave	CUP; Assemblies of People church and conference center within existing 64,910 sqft bldg		Existing 64,910		CC 3/11/14	Too far
C73	P13-0364 P13-0365	3399 Adams St	CUP, DR; Gas station, convenience store, car wash	0.51	2,941		CC 4/22/14	Too far

Map ID #	Case Number	Location	Project Description	Acres	Buildings Total Square Feet	Dwelling Units	Approval Date	Include?
C74	P14-0435	5005 Canyon Crest Dr	MCUP; Temporary use of 2 modular buildings for offices; Saint Andrew's Orthodox Church				ZA 5/22/14	Temporary use
C75	P13-0912 P13-0913	3742 Park Sierra Av	CUP, DR; LA Fitness Sports Club facility		45,000	-	CC 6/17/14	Too far
C76	P14-0220	4035 Trail Creek Rd	CUP; Allow occupancy of an existing 4,400 sqft industrial building for use as Sunday school classrooms and offices	-	Existing 4,400 sqft bldg	-	CC 6/17/14	Too far
C77	P13-0903 P13-0904	3865 Jackson St	CUP, DR; 18,650 sqft expansion of existing medical emergency department and construction of a 2,005 sqft utility building; Parkview Hospital Medical Center		20,655		6/19/2014	Too far
C78	P14-0457	6465 Sycamore Canyon Blvd	MCUP; Health & fitness club/studio under 4,000 sqft within existing 92,410 sqft 2-story office bldg	8.02	4,000		ZA 6/30/14	x
C79	P14-0132	7665 Vine St	CUP; Allow a materials (metal) processing facility to operate	2.25	2 existing bldgs, 30,324 sqft total	-	CC 7/8/14	Too far
C80	P14-0188 P14-0403	3390 Orange St	MCUP, COA; Use residential building as offices	0.21			ZA 7/21/14	Too far
C81	P14-0315 P14-0437	4334 Vine St	Revised CUP, DR; Security operations building for the adjacent Downtown Metrolink station		3,150 sqft		CPC 7/17/14	Too far
C82	P14-0450	2900 Adams St	Revised CUP; to establish classrooms and laboratories within 5 office and warehouse lease spaces; California Baptist University	9.78	9085 sqft		CPC 7/17/14	Too far
C83	P13-0967 P13-0968	NE cor Indiana & La Sierra Aves	CUP, DR; Gas station, car wash, detail center		7065 sqft		CPC 8/7/14	Too far
C84	P13-0165 P13-0166 P13-0167 P13-0168	Westerly side of La Sierra Ave, southerly of Indiana Ave, northerly of Liverpool Ln	CUP, DR, GPA, RZ; Request to construct a new gas station and car wash; GPA from Office to Commercial; Rezone from Single Family Residential to Commercial	6.83	-	-	CC 8/12/14	Too far
C85	P14-0525	3622 Adams St	MCUP; Convert apartments into student housing for California Baptist University				CC 10/09/14	Too far
C86	P14-0501 P14-0529 P14-0530	northwest corner of intersection of La Sierra Ave and Pierce Street	CUP, DR; Drive-thru fast food restaurant, Pharmacy Drive-thru, Commercial shopping center	5.21			CC 1/13/15	Too far
C87	P14-0673 P14-0675 P14-0928	northeast corner of Van Buren and Magnolia	CUP, LC, PC or N; Walgreens with Drive Thru pharmacy	0.73	10,776		CC 2/03/15	Too far
C88	P14-0812 P14-0813 P14-0979 P14-0980 P14-0981 P14-0982 P14-0983 P14-1076	9505 Magnolia	CUP, VA, DR; Sonic Dine in and Drive-Thru; VA for landscaping, Interior side landscape planter, minimum lot size, reduce drive-thru width, increase number of signs allowed, corner blade sign, reduce parking spaces.		3,275		CC 2/03/15	Too far

Map ID #	Case Number	Location	Project Description	Acres	Buildings Total Square Feet	Dwelling Units	Approval Date	Include?
C91	P14-0536 P14-0537	Valley Springs & Corporate Centre	CUP, DR; construct an approximately 3,750-square-foot drive-thru business ("Steak and Shake"), located at the northwesterly corner of Valley Springs Parkway and Corporate Centre Place, APN 291-460-017		3,750		CC 5/5/15	x
C92	P13-0087 P13-0262	2450 Market Street	CUP, DR; establish a 67-unit senior housing facility within an existing three-story, approximately 51,321-square-foot building, on an approximately 1.7-acre site, located at 2450 Market Street situated on the easterly side of Market Street between Ogden Way and Northbend Street, across from Fairmount Park	1.7	51,321		CC 5/5/15	Too far
C97	P15-0247 P15-0248 P15-0250 P15-0251 P15-0252 P15-0363	3744, 3768 and 3776 Main Street	CUP, TM, VR; construction of a mixed-use project, consisting of 91 residential units, approximately 8,841 square feet of commercial space and a 115-stall parking garage, on three parcels totaling 0.62 acres, partially developed with an existing commercial building (Imperial Hardware) and a surface parking lot	1.49				Too far
C98	P15-0155	4135 Chicago Avenue	CUP; Open a charter high school in a 10,000 square foot square site					Too far
M1	P05-1055 P05-1056 P05-1057 P05-1058 P05-1059	5202 La Sierra Ave	Tract Map 33403, PRD, GPA, RZ, DR; Sierra Park, 62 unit	7.50	-	62	CC 7/11/06	Too far
M2	P06-0501 P06-0554 P06-0555 P06-0056 P06-0557	4710 Riverwalk Pkwy	Parcel Map 34774, SP, RZ, DR, PP; Griffin Riverwalk Apartments	25.50	-	664	CC 10/3/06	Too far
M3	P06-1031	1562 Orange St	Tract Map 31825 time extension; Single Family Residences	2.08	-	7	CPC 10/5/06	Too far
M4	P06-0900 P08-0269 P08-0270	southwest corner of Lurin Av and Wood Rd	Tract Map 32301; Single Family Residences	10.50	-	20	CPC 4/19/07	Too far
M5	P07-0279	north of California Av, west of Bolton Av	TM35455 (RC Zone), Single family residential lots; Lionhead , RC Map	25.94	-	6	CC 5/27/08	Too far
M6	P07-1073	APN: 276060003, 012	Tract Map 32180; Subdivide 2 parcels into 9 Single Family Residences in the RE-RL Zone	9.62	-	9	CPC 6/5/08	x
M7	P08-0084	8616 California Ave	Parcel Map 35852; California Square Redevelopment (Condos)	6.00	-	21	CC 6/17/08	Too far
M8	P06-1355	APN: 266160006, 008, 017, 018	Tract Map 33480; Single Family Residences	21.14	-	32	CPC 7/3/08	Too far
M9	P06-1396	APN: 266140029, 030	Tract Map 33481; Single Family Residences	18.78	-	25	CPC 7/3/08	Too far
M10	P06-1404	APN: 266140002, 021, 022	Tract Map 33482; Single Family Residences	15.13	-	29	CPC 7/3/08	Too far

Conditional Use Permits

Map ID #	Case Number	Location	Project Description	Acres	Buildings Total Square Feet	Dwelling Units	Approval Date	Include?
M11	P05-0269 P08-0416	3719 Strong St	Tract Map 33550 and Rezoning of vacant parcels to establish 9 single family residential lots and rezone the property from Multiple Family Residential to Single Family Residential Zone	2.01	-	9	CC 9/16/08	Too far
M12	P06-0782	1006 and 1008 Clark St, north side of Paschels Way, east of Clark St, at the north terminus of Cozumel Ct	Tract Map 34908; single family residences	3.38	-	15	CC 1/6/09	Too far
M13	P05-1528 P09-0087	East of Gratton St, West of Corsica Ave, North of Van Buren Blvd	Tract Map 34509; 50 Single family lots; Phase I - Develop approx 60 acres to 11 subdivision lots	254.34	-	50	CC 11/06/07; CPC 4/23/09 (Phase I)	Too far
M14	P09-0141 P09-0173	South of Clarke St, west of Crystal View Terrace	Parcel Map 34583 to subdivide 2 vacant parcels into 3 single family residential lots; Rezoning 0.47 acres from R-1-1/2 to Residential Conservation Zone	5.72	-	3	CC 9/1/09	Too far
M15	P08-0396 P08-0397 P08-0398 P08-0399	NW corner of Dominion Av and Division St	Tract Map 35620; Design Review, General Plan Amendment, and Rezoning to establish a condominium complex	3.75	-	36	CC 11/10/09	Too far
M16	P07-1028 P06-0416 P06-0418 P06-0419 P06-0421 P07-0102	NW cor Alessandro Blvd & San Gorgonio Dr	TM 34707/EIR/ DR Alessandro Business Park 4 Industrial/Manufacturing Bldgs	36.63/80.07	662,018	-	CC 3/9/10; Final map approval CC 5/20/14	x
M17	P08-0727	6639 Hillside Ave	Parcel Map 35901; 5 lots for future industrial development	9.00	-	5	CPC 11/18/10	Too far
M18	P10-0577 P10-0671 P10-0672 P10-0798	La Sierra and Indiana Av	Riverwalk Vista Specific Plan - Village 4 (cross streets La Sierra and Indiana Avenue); Amend the Riverwalk Vista Specific Plan to allow two additional complexes (villages) to be developed. Tract Map 35932 to subdivide 21.89 acres of vacant land into 111 lots; additional Tract Map 36323 to subdivide 11.72 acres of vacant land into 52 lots located with the Single Family Residential Zone and Specific Plan (Riverwalk Vista) Overlay Zones	33.61	-	163	CC 2/22/11; Final map approvals CC 3/25/14	Too far
M19	P10-0113 P10-0118 P10-0449	19985 Van Buren Blvd; SW corner of Van Buren Blvd and Barton St	Parcel Map 36434 Scoping Session, EIR, DR; Gless Ranch - commercial retail shopping	40.00	425,447	-	CC 2/21/12	Too far
M20	P12-0021 P12-0022 P12-0074	3990 Reynolds Rd	Parcel Map 36442; General Plan Amendment to change property from C to MHDR; Rezoning from CR-SP and O-S-R-SP to R-3-3000-SP to consider the establishment of a 4-story multi-family residential development	9.7	-	102	CC 6/5/12	Too far

Map ID #	Case Number	Location	Project Description	Acres	Buildings Total Square Feet	Dwelling Units	Approval Date	Include?
M21	P11-0675 P11-0676	South of Arlington; between Royale Pl and Sunset Ranch Dr	Tract Map 36377 and PRD; 10 lot subdivision	13.9	-	10	CC 6/11/13	Too far
M22	P13-0389	NE cor Martha Way & Everest Ave	Tract Map 36579; subdivide 2 parcels to accommodate 5 single family dwellings	1.36	-	5	CPC 1/9/14	Too far
M23	P13-0723 P13-0724 P13-0725	4325, 4335, 4345, 4355, 4375 Adams St	Tract Map 36654, PRD, DR; subdivide 7.76 acres into 62 single family planned residential development	7.76	-	62	CC 2/25/14	Too far
M24	P12-0799 P12-0800	west side of Palm Av between Beechwood & Highland Pl	Tract Map 36516 and Design Review; subdivide 1.26 ac vacant parcel into 7 single family residential lots ranging in size from 7,002 to 8,011 sq.ft.	1.26	-	7	CPC 4/3/14	Too far
M25	TM 31147	North of intersection of Wycliffe & Buchanan Streets	Final approval of Tract Map 31147; 59 lot single family subdivision	27.09	-	59	CC 4/15/14	Too far
M26	P13-0665	18875 Moss Rd	Tract Map 36641; 8 lot subdivision for future development of single family residences	5.03	-	8	CPC 4/17/14	x
M27	P12-0601 P12-0697 P12-0698	14601 Dauchy Ave	Tract Map 36370; GPA from VLDR to HR; RZ from R-1-1/2 acre to RC; 10 lot subdivision	9		10	4/17/2014	Too far
M28	TM32997	SE cor Alta Crest Ave & Krameria St	Final approval of Tract Map 32997 (P06-0715), a 90 lot single family subdivision	38.6		94	CC 5/20/14	Too far
M29	P03-0041 P03-0042 P03-0086	both sides of Jurupa Ave bet. Crest & Rutland Aves	Tract Map 28987, GPA, RZ; Final approval of tract map; 113 lot single family subdivision	47.54		113	CC 6/17/14	Too far
M30	P14-0593	APN 135280041	Tract Map 34236, DR; 7 lot subdivision for residential			7	11/12/2014	Too far
M31	P14-0176	southwest corner of La Sierra and Victoria Avenues	Tract Map 36713, GPA, RZ; Final approval of tract map; 14 lot single family subdivision	8.8		14	CPC 12/18/14	Too far
M32	P13-0905 P13-0906	Northerly side of Arlington Avenue, between Royale Place and Hawarden Drive	Tract Map 36604, PRD; subdivide an existing 12.41 acre parcel having an average natural slope of 26.4% into seven lots for the future construction of single family residences, as well as the establishment of an approximately 5.20 acre open space area, four lettered lots, and a public cul-de-sac street; resulting in a density of 0.56 dwellings per acre in the RC – Residential Conversation zone	12.41		.56/acre		Too far
M33	P12-0393 P12-0394	Easterly side of Hawarden Drive, mid- block between Horace Street and Rolling Ridge Road	Parcel Map; subdivide an approximately 14.63 acre, two-parcel site into three parcels ranging in size from 1.02 to 11.61 acres; a variance for a flag lot, parcel 2, and to allow the existing parcel, located at 6260 Hawarden Drive, to increase from 0.63 acres to 1.02 acres in size, where the Hawarden Drive Special Design Area requires a minimum of 2.0 acres, located at 6240 and 6260 Hawarden Drive, in the RC – Residential Conservation Zone	14.63				Too far

Map ID #	Case Number	Location	Project Description	Acres	Buildings Total Square Feet	Dwelling Units	Approval Date	Include?
M34	P14-1053 P14-1054	Northerly side of Dan Kipper Drive, westerly of the intersection of Dan Kipper Drive and Sycamore Canyon Boulevard	Parcel Map;subdivide three existing parcels, totaling 13.08 acres into 5 lots to facilitate the development of 5 warehouse buildings ranging in size from 36,424 to 53,006 square feet in size.	13.08				x
M35	P14-0472 P14-0473 P15-0322 P15-0321	Northerly side of Grove Community Drive, between Trautwein Road and Worchester Lane	TM DR, VR; Tentative Tract Map (TM-39534); a related Planned Residential Development to subdivide an approximately 13.5 acre two-parcel vacant site, into 85 single family residential lots with common open space and shared amenities; the Design Review of the plot plan and building elevations for the proposed residential planned residential development; and variances related to building setback measurements in the R-1-8500-SP – Single Family Residential and Specific Plan (Orangecrest) Overlay Zones.	13.5				Too far

G1	P08-0300	7179 Magnolia Ave	Rezoning property from R-1-7000 to Office	0.41			CC 7/22/08	Too far
G2	P07-0425 P09-0196	Magnolia Ave bet Tyler and Buchanan Sts	Magnolia Avenue Specific Plan; General Plan Amendment involving a text change to the Circulation Element of the general plan increasing Magnolia Avenue from a four lane arterial to a six lane arterial between Tyler Street and Buchanan Street				CC 11/10/09	Too far
G3	P08-0125 P07-0790	5372-5392 and 5360 Tyler St	General Plan Amendment from Semi-Rural Residential to Public Facilities Institutional; Rezoning from R-3-1500 to Public Facilities; Elementary School Expansion	2.14	Contact School District		CC 1/27/09	Too far
G4	P08-0215 P08-0216	10035-10266 Gould St	General Plan Amendment to change approx 54 parcels from HDR to MDR; Rezoning of approximately 54 parcels developed with single and multiple family residences and two vacant parcels from R-3-1500 to R-1-7000-AP-D	21.40			CC 1/27/09	Too far
G5	P08-0823	3345 Madison	Rezoning from Single Family Residential to Commercial Retail	0.50			CC 2/24/09	Too far
G6	P09-0749	NW Alamo and Main Sts	Rezoning 41 parcels from Business Manufacturing Park to Industrial	54.22			CC 3/9/10	Too far
G7	P07-0682 P07-0683	1919 Atlas Dr; 4500 - 4590 Allstate Dr., 1950 and 2000 Market St and 4300 - 4371 Latham St	General Plan Amendment to O; Rezoning from CR to O; 13 parcels	14.09			CC 3/24/09	Too far
G8	P09-0002	2255 Chicago Avenue and 1725 – 1735 Spruce St	Rezone a commercial center from the I-SP to the I-BSR-SP Zone	1.70			CC 3/24/09	Too far
G9	P09-0551	3524 Central Ave	Rezoning property from the R-1-7000 to Commercial Retail in the Magnolia Avenue Specific Plan	0.44			CC 4/13/10	Too far
G10	P09-0112 P09-0113	APN: 234231045	Rezoning from R-1-7000 to Business Manufacturing Park; General Plan Amendment from MDR to B/OP	3.27			CC 5/26/09	No Trip Gen

Map ID #	Case Number	Location	Project Description	Acres	Buildings Total Square Feet	Dwelling Units	Approval Date	Include?
G11	P09-0424	7797 and 7779 Indiana Ave	Rezoning approximately .51 acres of vacant property on the northwesterly side of Indiana Avenue between Jefferson Street and Winstrom Street, from R-1-7000 to CG in the Riverside Auto Center Specific Plan	0.51			CC 10/13/09	Too far
G12	P10-0080	1989 Massachusetts and 2800 – 2880 Hulen Pl	Rezoning from the I zone to the I-ES zone	1.80			CC 6/8/10	Too far
G13	P10-0454	4825 Tequesquite Ave	General Plan Amendment to change the Tequesquite Park site from Private Recreational Use to Public Park	43.64			CC 5/17/11	Too far
G14	P10-0377	6458 Van Buren Blvd	Rezoning property from Business Manufacturing Park to Commercial Retail	4.04			CC 6/28/11	Too far
G15	P11-0595 P11-0596	3375 Arlington Ave	General Plan Amendment to change portion of property from Office to Public Facilities; Rezoning portion of property from Commercial General to Residential Commercial Zone	0.8			CC 7/24/12	Too far
G16	P12-0334	NE cor Tequesquite & San Andreas Aves	City initiated General Plan Amendment for compliance with the new Housing Element (2006-2014); From MHDR to HDR for consistency with R-3-1500 multi-family residential zone	2.8			CC 10/22/13	Too far
G17	P12-0336	West side of Chicago Ave bet University Ave & 12th St	City initiated Rezoning for compliance with the new Housing Element (2006-2014); From Commercial to Mixed Use Urban (MU-U-SP) in the University Avenue Specific Plan	17.8			CC 10/22/13	Too far
G18	P12-0336	9 parcels at SE cor of Duncan Ave & Van Buren Blvd	City initiated Rezoning for compliance with the new Housing Element (2006-2014); From Single Family Residential to Multiple Family Residential & Airport Protection Compatibility Zone E Overlay (R-3-1500-AP-E)	5.6			CC 10/22/13	Too far
G19	P13-0263 P13-0264	18171 Van Buren Blvd	GPA from VLDR to C; RZ from R-1-1/2 Acre-SP to CR-SP; to facilitate the development of a retail commercial center on 2 contiguous parcels	7.17			4/21/2014	Too far
G20	P13-0553 P13-0554 P13-0583 P14-0065	5940 and 5980 Sycamore Canyon	GP, SP, RZ, DR; 275-unit multiple-family residential development, including common and private amenities and covered and uncovered surface parking, on two contiguous parcels	10.26		275	CC 03/17/2015	x
G21	P14-0600, P14-0601, P14-0602 P15-0044	Southeasterly corner of Mt. Baldy Drive and San Gorgonio Drive	RZ, DR, VR, VC; consideration of 1) an Amendment to the Municipal Code (Title 19) to rezone approximately 6.2 acres from the CR-S-2-SP – Commercial Retail, Height of Building (two stories), and Specific Plan (Sycamore Canyon Business Park) Overlay Zones to the BMP-S-2-SP – Business and Manufacturing Park, Height of Building (two stories), and Specific Plan (Sycamore Canyon Business Park) Overlay Zones; 2) for Design Review of the plot plan and building elevations related to the construction of an approximately 121,390 square foot multiple tenant industrial building as associated surface parking and landscaping; 3) for a variance to permit a building to encroach into the required 40-foot front yard setback; 4) vacation of excess right-of-way beyond the terminus of the existing cul-de-sac on Mt. Baldy Drive	6.2	121,390			x

Conditional Use Permits

Map ID #	Case Number	Location	Project Description	Acres	Buildings Total Square Feet	Dwelling Units	Approval Date	Include?
G22	P13-0956 P13-0959 P13-0960 P13-0963 P13-0964 P13-0965 P13-0966	Southeast corner of Palmyrita Avenue and Michigan Avenue, and north of Sugarloaf Mountain	GP, SP, VC, TM, DR, MCUP, VR; Consideration of a phased development consisting of three (3) industrial buildings totaling approximately 1,461,449 square feet of Industrial Warehouse Distribution space	72.5				Too far

E1	P06-1237	Fourteenth St and Brockton Av	EIR and Design Review; Jacobs Medical Office (Formerly Chinatown Site)	4.6	65,281		CC 10/7/08	Too far
E2	P09-0600 P09-0601	5200 Van Buren Blvd	Environmental Impact Report (EIR) certifying that the adopted resolution for the Wal-Mart Expansion is pursuant of the County of Riverside Land Use Compatability Plan	13.73	125,857 (existing bldg) 22,272 (addition)		CC 1/24/12	Too far

V1	P08-0175	along easterly side of Sycamore Canyon Blvd, bet. Cottonwood Av and Alessandro Blvd	Vacation of approximately 5,822 square feet of unused right-of-way	5,822.00			CC 6/3/08	No Trip Gen
V2	P08-0329	Commerce St bet. Mission Inn and University Aves	Summary vacation of a portion of Commerce Street for future development	17,424.00			CC 7/22/08	Too far
V3	P08-0144	portion of Chicago Av and Ferrari Dr	Vacation of Street from La Fayette and Ferrari Drive	94,525.20			CC 9/23/08	Too far
V4	P08-0474 P08-0475	Intersection at Bushness Av, La Sierra Av, Hole Av, Pierce St	Traffic Pattern Modification at Five Points Intersection; Designation of Five Points as City Historic Landmark	N/A			CC 10/7/08	Too far
V5	P08-0549	Intersection at Antioch and Hillside Aves	Traffic Pattern Modification at Antioch at Hillside	43,560.00			CC 10/28/08	Too far
V6	P08-0303 P08-0304 P08-0306	Santa Ana Ave between Jack B. Clarke Way and Ninth St; Jack B. Clarke Way between Santa Fe Avenue and the Railroad; Ninth St between Vine St and the Railroad; and 3141 Ninth St (packinghouse)	Street vacation of approximately 11,000 square feet of Santa Ana Ave between Jack B. Clarke Way and Ninth St; approximately 2,760 square feet of Jack B. Clarke Way between Santa Fe Avenue and the Railroad; and approximately 20,000 square feet of Ninth St between Vine St and the Railroad; Variance for parking; Certificate of Appropriateness to rehabilitate and adaptively re-use existing 2-story 20,212 sq.ft. historic packing house as an office; demolition of existing 6,637 sq.ft. rear addition constructed in 1939, in conjunction with proposed 3-story, 19,625 sq.ft. office addition	33,760.00			CC 11/18/2008; CHB 7/16/08	Too far

Map ID #	Case Number	Location	Project Description	Acres	Buildings Total Square Feet	Dwelling Units	Approval Date	Include?
V7	P09-0130	ROW adjacent to 5236 Olivewood Av bet. Panorama and Boxwood Roads	Summary Vacation of portion of Olivewood Ave	18,982.51			CC 5/5/09	Too far
V8	P08-0749	ROW adjacent to 6692 Indiana Ave; ROW adjacent to 3355 Jane St bet. Indiana Av and BNSF Railroad	Summary Vacation of portion of Indiana Ave and Jane St	12,465.00			CC 5/26/09	Too far
V9	P09-0205 P09-0206	Dufferin Av from Stewart St to McAllister Pkwy	Street Vacation and Traffic Pattern Modification to construct knuckle at Dufferin Ave and Stewart St and to prohibit vehicle access at Dufferin Ave from McAllister Parkway	23,846.06			CC 7/14/09	Too far
V10	P09-0378	Monroe St southwest of California Ave	Summary vacation of approximately 0.213 acres of unimproved right of way along Monroe Street, southwesterly of California	9,278.28			CC 7/28/09	Too far
V11	P09-0217	alley between 4290, 4310 Oakwood Pl and 4291, 4319 Rosewood Pl	Vacation of an alley	4,440.00			CC 8/25/09	Too far
V12	P09-0505	portion of cul-de-sac bulb adjacent to 5696-5698 Peggy Ln, westerly of Chadbourne Ave	Summary vacation of approximately 4,425 square feet of unused right-of-way located at the westerly terminus of Peggy Lane	4,425.00			CC 10/6/09	Too far
V13	P09-0199	south side of Ninth street, between Orange and Lemon Streets	Vacate an existing alleyway to become a part of an alley port entry in conjunction with a 10-story Office Bldg at 3940-3998 Orange St	2,752.00			CC 1/5/10	Too far
V14	P10-0001	Stub portion of Ninth St bet. Lime St and 91 Freeway	Vacate a portion of Ninth St; located between Lime Street and Highway 91	6,600.00			CC 5/25/10	Too far
V15	P09-0135	Tenth and Eleventh Streets bet. Lime St and	Close remaining portion of Tenth and Eleventh Streets				CC 10/5/10	Too far
V16	P10-0667	alley bet. Sixth St, Mission Inn Ave, Main St, and Market St	Summary vacation of approximately 1,605 square feet of excess right-of-way	1,605.00			CC 1/18/11	Too far
V17	P10-0799	end of Payton Ave	Summary vacation of the remaining of unused public Right of Way for 5894 Payton Ave	53,654.43			CC 3/22/11	Too far
V18	P09-0810	Eucalyptus St, south of Vasquez St	Vacate a portion of Eucalyptus, southerly of Vasquez Street	4,286.74			CPC 5/5/11	Too far
V19	P11-0011	21 ft. of ROW along Palm Ave at Rubidoux Ave	Summary vacation of approximately 2,722 square feet of excess right-of-way located at the intersection of Palm Ave and Rubdioux Ave	8,968.00			CC 6/14/11	Too far

Map ID #	Case Number	Location	Project Description	Acres	Buildings Total Square Feet	Dwelling Units	Approval Date	Include?
V20	P11-0199	Fairmount Blvd bet. Whittier Pl and University Ave	3892 University Ave, 3902 University Ave, 3892 University Ave, 3907 University Ave, 3907 Whittier Pl; Vacation summary of a portion of Fairmount Blvd. between Whittier Pl. and University Ave. to construct the Riverside Community College Culinary Institute with an underground parking structure	15,566.00			CC 7/26/11	Too far
V21	P11-0502	Magnolia Ave adjacent to Palm Shadows Apartments (3697 Monroe St) bet. Adams and Monroe Streets	Summary vacation to vacate an excess right-of-way along Magnolia Ave in the Magnolia Avenue Specific Plan	679,543.00			CC 11/8/11	Too far
V22	P11-0599	alley south of the western terminus at 3716 Elizabeth St and north of the Union Pacific Railroad ROW	Summary Vacation of an approximately 25-foot wide by 149-foot long segment of public alley in the Magnolia Avenue Specific Plan	7,043.00			CC 12/6/11	Too far
V23	P09-0794	alley in block surrounded by Mission Inn Ave, Sixth St, Market St, and Fairmount Blvd	Summary vacation of a 15 foot wide alley	5,400.00			CC 1/17/12	Too far
V24	P11-0601	alley bet. Seventh St and University Ave, easterly Mesa St	1764 Seventh St; Summary vacation approximately 120-foot by five-foot wide portion of public alley, located between Seventh Street and University Avenue, easterly of Mesa Street, adjacent to the southerly property lines of 1764 and 1774 Seventh Street. The approximately 600 square-foot area to be vacated can be considered excess right-of-way and is no longer needed for street purposes	600.00			CC 2/7/12	Too far
V25	P12-0127	3649 Mission Inn Ave	Summary Vacation of approximately 116-foot by 19-foot segment of excess right-of-way situated on the easterly side of Main Street and Southerly of Sixth Street with the Downtown Specific Plan Raincross District Commercial Retail Zone	2,204.00			CC 5/1/12	Too far
V26	P12-0136	6900 Jurupa Ave	Summary Vacation of approximately 6,937 square feet of unused public right-of-way and authorize the preparation of a Certificate of Compliance to incorporate the vacated area into the property of 6900 Jurupa Avenue within the Business Manufacturing Park Zone	6,937.00			CC 5/15/12	Too far
V27	P11-0543 P10-0762 P10-0763	Magnolia Ave adjacent to 7431 and 7451 Magnolia Ave	Summary vacation of a segment of public right-of-way along the frontage of 7431 and 7451 Magnolia Ave, which is developed with an apartment complex and related parking areas in the Magnolia Avenue Specific Plan	51,179.00			CC 5/22/12	Too far

Conditional Use Permits

Map ID #	Case Number	Location	Project Description	Acres	Buildings Total Square Feet	Dwelling Units	Approval Date	Include?
V28	P12-0066	4900 Golden Ave	Summary Vacation of approximately 11-foot wide by 822-foot long segment of excess public right-of-way on the westerly side of Golden Ave and an approximately 12-foot wide by 766-foot long segment of public right-of-way on the northerly side of Pierce Street located within the Residential Estate Zone	18,234.00			CC 9/11/12	Too far
V29	P13-0657	NW cor Van Buren Blvd & Magnolia Ave	Summary Vacation of excess right of way				CC 10/22/13	Too far
V30	P13-0728	Stacy Ct bet. Paige Dr & Columbia Ave	Summary Vacation				CC 10/22/13	Too far
V31	P12-0309	Monte Vista & Pollard	Vacation of approximately .5-acre of public right-of-way, consisting of portions of Monte Vista Drive and Pollard Way, adjacent to the properties at 739 and 778 Monte Vista Drive for a proposed 88-unit apartment project			88	CPC 03/19/15	x
V32	P14-0149	Diana Avenue between Adams and Monroe Streets	Vacation of Diana Avenue between Adams and Monroe Streets, including Wilma Court and Emily Court in their entirety, the area to be vacated is approximately 3.4 acres, in Ward 5	3.40				Too far

D1	P08-0701 P08-0702	4393 Tyler St	DR, Rezoning from R-1-7000 to Office; Remodel and reuse of multi-family buildings as offices	0.49	4,950	-	CC 4/21/09	Too far
D2	P10-0406 P10-0407 P10-0408	11500 Magnolia Ave	Site Plan Review, Design Review, Variance; Apartment Complex	7.60	-	168	CC 1/11/11	Too far
D3	P12-0184 P12-0185 P12-0187	9241 and 9265 Audrey Ave	General Plan Amendment to change property from MDR to C; Rezoning from R-1-7000 to C; and Design review to facilitate the construction of a multiple tenant retail building on a two parcel site, known as the Azar Plaza	0.6	6,150	-	CC 11/13/12	Too far
D4	P12-0507 P12-0508 P12-0509 P12-0510	2325 Cottonwood Av	DR, VR LLA, LS/I; 235,741 sqft addition to an existing 400,580 sqft warehouse/ industrial building	9.5 project site	636,321	-	ZA 12/7/12	Built
D5	P12-0717	1710 Main Street	Family Dollar store	1.01	8,039	-	ZA 3/11/13	Too far
D6	P12-0741 P12-0743 P14-0238	3545 Central Ave	Riverside Plaza renovations; Pad 3 renovations to consist of 7 tenant spaces with outdoor dining	35.00	-	-	ZA 6/7/13; ZA 7/9/14	Too far
D7	P13-0038 P13-0441	3683 Adams St	Rezoning property from Single Family Residential to Mixed Use Neighborhood Zone in the Magnolia Avenue Specific Plan; Design Review for conversion of an existing single family residence into a live/work unit	0.32	1237 (existing residence)	1	CC 8/27/13	Too far
D8	P12-0729 P12-0727	4015 Madison St	RZ/DR; Rezoning from R-1-7000 to O-S-1 to accommodate the expansion of parking lot for existing medical office	0.26	-	-	CC 9/24/13	Too far
D9	P13-0198 P13-0199 P13-0200 P13-0201	5731, 5741, 5761, & 5797 Pickler St	GP, RZ, COA, PPE; Proposal for rehabilitation of Camp Anza Officer's Club and development of affordable housing with on-site support services for disabled veterans and their families; Rezoning from single family to multi-family (apartment units)	2.14	-	30	CC 11/19/13	Too far

Conditional Use Permits

Map ID #	Case Number	Location	Project Description	Acres	Buildings Total Square Feet	Dwelling Units	Approval Date	Include?
D10	P13-0501 P13-0502	3705 Tyler St	PPE, DR; Demolish existing tire building and construct new 2-Tenant Restaurant building within existing shopping center	10.80	6,000	-	CC 12/3/13	Too far
D11	P13-0916 P13-0917 P13-0918 P13-0919	10403-10485 Magnolia Ave	DR, RZ, SitePlan Review, VR; Time extension for P05-1521, P08-0706, P08-0740, P08-0794; Magnolia Square mixed use development, Parcel map 36112	16.6	71,211 commercial/retail	315 multi-family; 3 live/work	12/16/2013	Too far
D12	P13-0247 P13-0248 P13-0249 P13-0251 P13-0252	9565 Rudicill St	Apartment complex on 4 lots (to be consolidated); Site Plan Review, DR, GPA from B/OP to HDR, Rezone from BMP-SP to R-4-SP, SPA (Citrus Business Park Specific Plan)	4.05	-	102	CC 8/12/14???	Too far
D13	P13-0607 P13-0608 P13-0609 P13-0854	SE cor Sycamore Canyon Blvd & Box Springs Rd	Multi-tenant industrial building; GPA, RZ, DR, SPA to remove site from Sycamore Highlands SP and add it to Sycamore Canyon Business Park SP		171,616	-	CC 5/13/14	x
D14	P13-0207 P13-0208 P13-0209 P13-0210 P13-0211	4445 Magnolia Ave	EIR, GPA, RZ, DR, SP; Riverside Community Hospital proposed expansion				CC 5/20/14	Too far
D15	P13-0324 P13-0325 P13-0326 P13-0327	Northerly side of Indiana Ave, Easterly of La Sierra Ave, adjacent to La Sierra Metrolink station	Transit-oriented residential development; Site Plan Review, DR, Rezone from R-1-7000-SP to MU-U-SP, SPA (Riverwalk Vista Specific Plan)	3.7	-	187	CPC 5/8/14	Too far
D16	P13-0563 P13-0564	8069 Indiana Ave	DR,VAC; construction of 7,373 sqft addition to facilitate vehicle service and parts sales; Singh Subaru; vacation of Susan Street between Indiana Ave & SR91		7,373		CC 6/3/14	Too far
D17	P14-0318	3502 through 3520 Tyler St	PPE, DR; Construct a 10,000 sqft restaurant building; add façade improvements to an existing retail building		10,000		ZA 7/11/14	Too far
D18	P14-0183	3105 Market St	DR; Centerpointe Apartments	2.51		146	1/26/2015	Too far
A1	P14-0246	NW cor of Sycamore Canyon Blvd & Central Ave	Annexation of a vacant site to facilitate development of retail commercial shopping center	9.4			CC 7/8/14	x



City of Moreno Valley Economic Development Summary

COMMERCIAL / RETAIL

99¢ Only Store – 14,000 sq. ft. retail store located at the SEC of Frederick and Cottonwood – OPEN

Alessandro and Lasselle: Proposed 140,000 sq. ft. center at the NEC, anchored by a 95,000 sq. ft. **WinCo Foods** - APPROVED / PROJECT ON HOLD

Alessandro Plaza: 122,000 sq. ft. center east of Heacock on Alessandro - anchored by **24hr Fitness**.

- **Leslie's Fashions** - 1,350 sq. ft. women's apparel store - OPEN

Bear Valley Plaza: Neighborhood shopping center located at the NEC of Alessandro and Perris.

- **Smart & Final:** 25,000 sq. ft. – IN PLAN CHECK

Burger King – remodel of vacant fast food restaurant at 24800 Sunnymead – OPEN

Canyon Springs Plaza: Community shopping center located North of SR60 on Day

- **Club Status** – 11,000 sq. ft. nightclub with live entertainment – TENANT IMPROVEMENTS UNDERWAY
- **Hangar Trampoline Park** – 34,500 sq. ft. indoor trampoline park – OPEN
- **Hollywood Hall-** 9,500 sq. ft. event facility – OPEN
- **Hibachi Grill & Super Buffet-** 13,000 sq. ft. restaurant – OPEN

Elsworth Plaza: A mixed-use retail / office/ restaurant center with three new buildings totaling 30,000 sq. ft. at the SWC of Alessandro and Elsworth:

- **Mr. Taco** – 1,200 sq. ft. pizza-to-go shop – OPEN

Flaming Grill Restaurant: 22420 Cactus Avenue – OPEN

Food 4 Less: Two retail centers are expanding

- NEC Perris and Hemlock is adding an on-site fuel station – OPEN
- NWC Alessandro and Indian: adding a fuel station across the street (at NEC) – OPEN

Ironwood Plaza: Neighborhood shopping center at the NWC of Ironwood and Heacock

- 99 ¢ Only Store – OPEN
- Bank of America drive up ATM kiosk – OPEN

Lakeshore Village Marketplace:

- 140,000 sq. ft. center on Sunnymead Ranch Pkwy. Grocery anchor and shop space – AVAILABLE
- **Armando's Mexican Food-** 1,800 sq. ft.- OPEN

Lakeside Plaza: Neighborhood shopping center at the NWC of Lasselle and Iris, anchored by Stater Bros.

- **Ranchitos Taco al Carbon** – OPEN
- **The Pizza Factory** – OPEN

Lakeside Terrace: Neighborhood shopping center at the NEC of Lasselle and Iris anchored by Dollar Tree, CVS Pharmacy, and Chase Bank.

- **Marcos Pizza** – 1,700 sq. ft. pizza restaurant – OPEN

RETAIL





City of Moreno Valley Economic Development Summary

RETAIL

Moreno Beach Plaza: 368,000 sq. ft. shopping center anchored by **Walmart Super Center, LA Fitness**, and includes **Payless Shoes, Schools First Credit Union, and US Bank.**

- **Auto Zone** – 7,600 sq. ft. auto supplies - OPEN
- **Sprint** – 3,000 sq. ft. cellular equipment and accessories store - OPEN

Moreno Marketplace: located at the NWC of Moreno Beach and Cactus, anchored by **Stater Bros and Wells Fargo Bank**, and includes **Jack-in-the-Box and Rancho Belago Dance Studio.**

- **Jersey Mikes:** 1,250 sq. ft.- TENANT IMPROVEMENTS UNDERWAY

Moreno Valley Auto Mall: Dealership renovations/expansions – COMPLETE & OPEN

Moreno Valley Mall: New retailers now open at the 1.1 million sq. ft. Moreno Valley Mall include:

- **Crunch Gym** – 20,000 sq. ft. - OPEN
- **El Paso** – (food court) OPEN
- **Image** – 10,000 sq. ft. apparel store – OPEN
- **Potato Corner** – OPEN
- **Tilly's** – 7,129 sq. ft., 2nd Floor – OPEN

Moreno Valley Plaza: 341,000 sq. ft. commercial shopping center anchored by **Office Depot, Superior Warehouse, Big Lots, Harbor Freight Tools, and CitiTrends** at the SWC of Sunnymead and Heacock.

- **4,600 sq. ft. restaurant** - AVAILABLE
- **Namaste Trading** – 1,500 sq. ft. women's apparel store - OPEN
- **Big Fish Market** - OPEN

O'Reilly Automotive: 7,500 sq. ft. retail store at the SWC of JFK and Perris – IN PLAN CHECK

O'Reilly Automotive: 7,500 sq. ft. retail store at the north side of Sunnymead between Olivewood Plaza and Graham – UNDER CONSTRUCTION

Pigeon Pass Plaza: Center at the NWC of Ironwood and Pigeon Pass. Anchored by the “Blue Ribbon” Stater Bros Market – OPEN

Plaza Del Sol: 56,000 sq. ft. center at the NEC of Alessandro and Frederick.

- **Caliente Restaurant** - OPEN
- **9,000 sq. ft. restaurant** – AVAILABLE

Rancho Belago Plaza: Retail center with two new buildings and a total of 14,000 sq. ft. at the SWC of JFK and Moreno Beach – APPROVED

Stoneridge Towne Centre – 579,000 sq. ft. commercial center at the SEC of SR60 and Nason, anchored by **Super Target, Dress Barn, Kohl's.** Includes **Chili's restaurant, US Bank, Visterra Credit Union, and Wachovia Bank.**

- **5,700 sq. ft. restaurant** - AVAILABLE
- **China One Kitchen** – 1,600 sq. ft. – OPEN
- **Hear USA** – 1,000 sq. ft. hearing aid center – OPEN
- **Kirkland's Home Décor** – OPEN
- **Taco Bell** - 2,562 sq. ft. Mexican restaurant – OPEN





City of Moreno Valley Economic Development Summary

TownGate Crossing: 250,000 sq. ft. shopping center expanding at the SEC of Day St. and SR60. Anchors include **Anna's Linens, Lowe's, Sports Authority & 99¢ Only Store, Buffalo Wild Wings, and Panera Bread.**

- **Pizza Five85:** 2,536 sq. ft. pizzeria - OPEN

TownGate Promenade: 353,000 sq. ft. shopping center at the SEC of Day and Campus. Anchored by **Costco, Ayres Hotel & Spa and Hampton Inn.** Tenants include **Applebee's, Mimi's Café, Panda Express, Bakers Drive-Thru.**

- **24-Hour Fitness:** Super Sport Club - OPEN
- **Rivals Sports Bar & Grill** – IN PLAN CHECK
- **Aldi Market:** 20,300 sq. ft. grocery market – IN PLAN CHECK

TownGate Square: A mixed-use development anchored by **WinCo Foods** with 136,000 sq. ft. of retail / restaurant including **Portillo's**, plus 170,000 sq. ft. of approved office at the SEC of Gateway and Day.

- **Miguel's Jr. Restaurant** - 2,800 sq. ft. fast-casual restaurant, with drive-thru - OPEN

Walmart: Proposed 193,000 sq. ft. at the SWC Perris and Gentian, includes a gas station or a fast food restaurant and retail shop - ENVIRONMENTAL IMPACT (EIR) REPORT UNDERWAY

Yum Yum Donut Shop: Proposed 4,351 sq. ft. donut shop and convenience store at the NWC of Day and Alessandro - IN PLANNING

HOTEL / HOSPITALITY

Cactus and Elsworth: Proposed four-story Hawthorn Inn & Suites with 79-guest rooms – APPROVED

Olivewood Plaza: Proposed three-story Sleep Inn Suites with 66 guest rooms – APPROVED

MEDICAL / OFFICE

Fresenius Medical Care – 12,000 sq. ft. one-story dialysis center at the NWC of Iris and Oliver - UNDER CONSTRUCTION

Integrated Care Communities: 99-bed skilled care nursing facility in 44,000 sq. ft. Brodiaea west side of Nason – OPEN

Moreno Valley Professional Center: 84,000 sq. ft. in 4 office buildings on Alessandro east of Elsworth – APPROVED

Olivewood Plaza: 23,000 sq. ft. three-story office building on 1.10 acres located north of Sunnymead and west of Graham – APPROVED

Renaissance Village of Moreno Valley: A proposed 140-bed senior assisted living facility on the SWC of Moreno Beach and Brodiaea for a total of 98,000 sq. ft. on 7.33 acres – OPEN

Riverside County Office Building: A 52,000 sq. ft. office building on the SWC of Heacock and Webster – UNDER CONSTRUCTION

HOTEL

OFFICE





City of Moreno Valley Economic Development Summary

INDUSTRIAL

CENTERPOINTE INDUSTRIAL AREA

An industrially-zoned specific plan area with existing facilities for **BAS Recycling, CIMC, Frazee Paint, Minka Lighting, National Tube Supply, Porvene Doors, ResMed, Serta Mattress, Supreme Truck Bodies, United Natural Foods Inc., and US Post Office.**

NEW PROJECTS INCLUDE:

Gateway Business Park: 34 industrial condos between 5,000 and 10,000 sq. ft., (total of 184,000 sq. ft.) south of Alessandro, west of Day – APPROVED.

Centerpointe Business Park: Ridge Property Trust is developing more than 2.66 million sq. ft. in 12 buildings (includes Minka Lighting, ResMed, Serta Mattress, Frazee Paint and U.S. Postal Service Distribution Center) – between Alessandro, Frederick, Cactus, and Heacock.

- **Harbor Freight Tools:** Occupies a 779,000 sq. ft. distribution center at the NWC of Cactus and Graham. Their 508,000 sq. ft. expansion is COMPLETE

Prologis Centerpointe: 602,000 sq. ft. distribution facility at the NWC of Brodiaea and Graham – IN PLAN CHECK.

Serta Mattress – expanding to 532,926 sq. ft. manufacturing and distribution facility.

Concourse at Centerpointe: Liberty Mutual’s 523,000 sq. ft. facility at the NWC of Cactus and Frederick has been leased to Federal-Mogul, a supplier of automotive parts. – OCCUPIED.

Robertson’s Ready-Mix: Concrete batch plant at Old 215 Frontage south of Alessandro – RELOCATED AND OPEN

Veterans Wy Logistics Center: 366,698 sq. ft. distribution facility at the SWC Veterans and Newhope – UNDER CONSTRUCTION

MORENO VALLEY INDUSTRIAL AREA

An industrially-zoned specific plan area with existing facilities for **Cardinal Glass, Harman Kardon, iHerb, Lowe’s Home Improvement, Masonite International, Modular Metal Manufacturers, O’Reilly Auto Parts, Phillips Electronics, Ross Dress for Less, Walgreens, Amazon, and Procter & Gamble.**

NEW PROJECTS INCLUDE:

Amazon: Trammell Crow developed Amazon’s award-winning Moreno Valley Fulfillment Center in two buildings at the NEC of Heacock and San Michele, totaling 1.25 million sq. ft. – OPEN
Amazon also operates a 769,000 sq. ft. inbound receiving facility at the NWC of Nandina and Indian for Amazon’s warehouses in California and Arizona – OCCUPIED

Deckers Outdoor: Vogel Engineers Inc. and Sares-Regis are developing a 1.6 million sq. ft. distribution facility on 71.15 acres along the Oleander Storm Channel between Indian and Perris 800,000 sq. ft. Phase I – UNDER CONSTRUCTION



INDUSTRIAL



City of Moreno Valley Economic Development Summary

INDUSTRIAL

First Industrial Realty Trust:

INDUSTRIAL

- **First 36 Logistics** – 569,000 sq. ft. industrial complex warehouse facilities at Perris and the storm channel – COMPLETED
- **First Inland Logistics Center** – 692,000 sq. ft. leased and occupied by **Harbor Freight Tools** - OPEN
- 400,000 sq. ft. entitled and approved distribution facility in two buildings. North side of Nandina west of Perris – APPROVED
- **First Nandina Logistic Center Realty Trust** - 1.45 million sq. ft. distribution center on 72.9 acres at the SWC of Indian and Nandina - EIR UNDERWAY

IDS / Real Estate Group - Nandina Distribution Center: Two buildings at the NWC of Nandina and Indian total - 1.47 million sq. ft.

- Building A: 697,000 sq. ft. – APPROVED
- Building B: 769,000 sq. ft. a receiving point for Amazon's warehouses in California and Arizona – OCCUPIED

Minka Lighting. Alere Property Group is constructing a 356,000 sq. ft. distribution center on 15.84 acres north of San Michele and east of Indian – OCCUPIED

Modular Logistics Center: Proposed 1.1 million sq. ft. distribution facility on approximately 50.84 acres at the NEC of Perris and Modular - APPROVED

Procter & Gamble: Developed by Panattoni Development Company the Inland Empire Global Logistics Center – 1.5 million sq. ft. at the SWC of Indian and Iris – OCCUPIED

Rados: Seven building project at NEC of Heacock and Iris – APPROVED

- 6 buildings ranging from 23,000 to 49,000 sq. ft.
- 410,000 sq. ft. distribution center.

Western Realco - March Business Center: Four distribution buildings at the SEC of Iris and Heacock total 1.48 million sq. ft. – IN PLAN CHECK & GRADING UNDERWAY

SR - 60 CORRIDOR

Aldi Foods - Regional Headquarters and Distribution Center: 825,480 sq. ft. building along the south side of SR60 between Quincy and Redlands – UNDER CONSTRUCTION.

Prologis Eucalyptus Industrial Park: 1.5 million sq. ft. proposed in four buildings (ranging from 160,000 to 862,000 sq. ft.) on the south side of SR-60 between Pettit and Quincy - APPROVED

World Logistics Center: Proposed specific plan master planned 41 million sq. ft. corporate park on 2,800 acres south of SR-60 and east of Redlands – EIR UNDER REVIEW



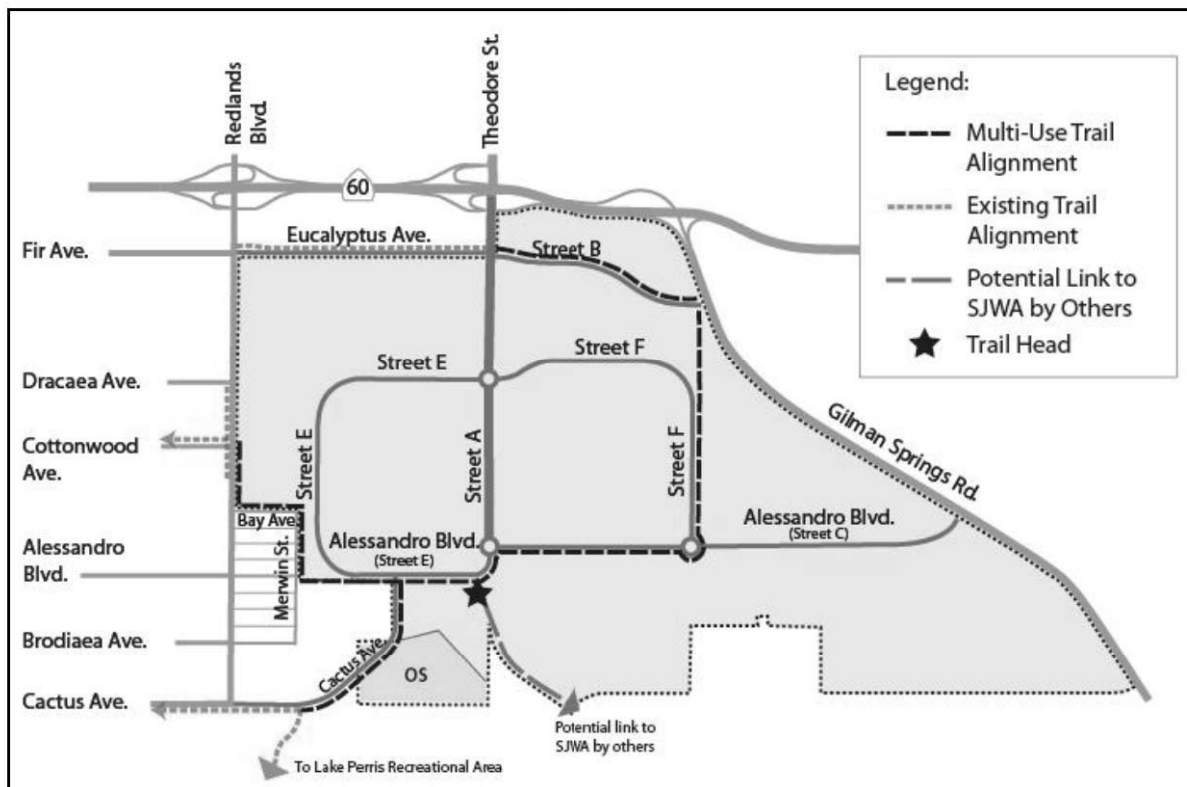

Figure 38: Proposed Multi-Use Trails

Phasing

The WLC would be developed over a number of years. For planning purposes it was assumed that Phase 1, to be completed by 2022, would contain approximately 21,450,000 square feet of logistics warehouse uses. This is approximately 52% of the total project building space. At that time, the road system would be partially built out (see Figure 22) with east-west through traffic served by Cactus Ave. Extension and Streets C and E, and north-south traffic served by Theodore St.

For Phase 2, full build-out of the project was assumed. An additional east-west through route would be provided when Eucalyptus Ave. (Street B) is connected with Redlands Blvd. to the west and Gilman Springs Rd. to the east.

C. PROJECT TRIP GENERATION

As was discussed in an earlier chapter, in order to ensure that the traffic forecasts would be conservative (i.e. not underestimate actual volumes) the trip generation rates selected for use in this study were the rates found in the latest edition of ITE's *Trip General Manual*. These rates are shown in Table 23.

Table 23: Trip Generation Rates for Proposed and Existing Land Uses

Land Use Type	Unit	AM Peak Hour			PM Peak Hour			ADT
		In	Out	Total	In	Out	Total	
Proposed Land Uses								
High-Cube Logistics Center (ITE 152)	KSF	0.076	0.034	0.110	0.037	0.083	0.120	1.680
Light Logistics (ITE 150)	KSF	0.237	0.063	0.300	0.080	0.240	0.320	3.560
Utilities Servicing Station (ITE 170)*	KSF	0.720	0.080	0.800	0.342	0.418	0.760	8.000
Fire Station**	Site	20	8	28	10	20	29	137
Gas Station w Convenience Store (ITE 945)	Pumps	5.08	5.08	10.16	6.76	6.76	13.51	162.78
Convenience Store (ITE 851)	KSF	33.52	33.52	67.03	26.73	25.68	52.41	737.99
Existing Land Uses								
Single-Family Dwellings (ITE 210)	DU	0.188	0.563	0.750	0.630	0.370	1.000	9.520
Utilities Servicing Station (ITE 170)*	KSF	0.720	0.080	0.800	0.342	0.418	0.760	8.000

"KSF" means "thousand square feet"

* Note: AM directionality taken from table for trips/employee. Daily rate is assumed to be ten time peak-hour rates

** Fire Station rate is based on the average of three traffic studies:

Fehr and Peers, *Loyola Marymount University Master Plan Project*, City of Los Angeles Department of Transportation, 2009, Table 5.

LLG Engineers, *Peaceful Valley Ranch*, County of San Diego, 2007, page 11.

McMahon, *Upper Dublin Fire House*, Montgomery County, Pennsylvania, 2010, page 15.

Using these rates, the trips that would be generated by the WLC are shown in Table 24 and Table 25.

Table 24: Trips Generated by Proposed and Existing Land Uses

Land Use Type	Unit	Amount	AM Peak Hour			PM Peak Hour			ADT
			In	Out	Total	In	Out	Total	
Proposed Land Uses									
High-Cube Logistics Center	KSF	40,400	3,066	1,378	4,444	1,503	3,345	4,848	67,872
Light Logistics	KSF	200	47	13	60	16	48	64	712
SCG Valve/Metering Station (ITE 170)	KSF	0.15	0	0	0	0	0	0	1
SDG&E Gas Compression Station (ITE 170)	KSF	30.3	22	2	25	11	13	23	247
Fire Station	Site	1	20	8	28	10	20	29	137
Gas Station with Convenience Store (ITE 945)	Pumps	12	5	5	11	10	10	21	219
Convenience Store (ITE Category 851)	KSF	3	11	11	22	13	12	25	354
Total			3,172	1,417	4,590	1,563	3,449	5,010	69,542
Existing Land Uses									
Single-Family Dwellings (ITE 210)	DU	7	1	4	5	4	3	7	67
SCG Valve/Metering Station (ITE 170)	KSF	0.15	0	0	0	0	0	0	1
SDG&E Gas Compression Station (ITE 170)	KSF	30.3	22	2	25	11	13	23	247
Total			24	6	30	15	16	31	314

Table 25: WLC Trips by Vehicle Type ³⁶

Vehicle Type	Surface Street PCEs	Freeway PCEs	AM Peak Hour						PM Peak Hour						Daily		
			Vehicles			PCEs			Vehicles			PCEs			Vehicles	Surface Street PCEs	Freeway PCEs
			In	Out	Total	In	Out	Total	In	Out	Total	In	Out	Total			
PHASE 1																	
Autos	1.0	1.0	1,197	466	1,663	1,197	466	1,663	412	1,396	1,807	412	1,396	1,807	30,879	30,879	30,879
Light Trucks	1.5	1.5	97	55	152	146	83	229	77	90	167	115	135	251	1,340	2,009	2,009
Medium Trucks	2.0	1.5	130	74	204	260	148	408	103	121	223	206	241	447	1,792	3,585	2,689
Heavy Trucks	3.0	1.5	345	197	542	1,035	590	1,625	273	320	594	820	961	1,781	4,760	14,279	7,140
Total			1,769	792	2,561	2,638	1,287	3,924	866	1,927	2,792	1,554	2,733	4,286	38,771	50,753	42,717
PHASE 2																	
Autos	1.0	1.0	923	356	1,279	923	356	1,279	313	1,075	1,388	313	1,075	1,388	23,835	23,835	23,835
Light Trucks	1.5	1.5	75	43	118	113	64	177	60	70	130	90	105	195	1,046	1,569	1,569
Medium Trucks	2.0	1.5	100	57	157	200	114	314	79	93	173	159	187	345	1,389	2,778	2,083
Heavy Trucks	3.0	1.5	266	151	418	799	454	1,253	211	248	459	633	744	1,376	3,680	11,040	5,520
Total			1,365	606	1,971	2,035	987	3,023	663	1,486	2,149	1,194	2,110	3,305	29,950	39,222	33,007
Full Build-out																	
Autos	1.0	1.0	2,120	821	2,941	2,120	821	2,941	726	2,471	3,195	726	2,471	3,195	54,714	54,714	54,714
Light Trucks	1.5	1.5	172	98	270	271	259	406	137	160	297	205	241	446	2,385	3,578	3,578
Medium Trucks	2.0	1.5	230	131	361	460	262	722	182	214	396	365	428	792	3,181	6,363	4,772
Heavy Trucks	3.0	1.5	611	348	959	1,834	1,044	2,878	484	568	1,052	1,453	1,704	3,157	8,440	25,319	12,660
Total			3,134	1,398	4,532	4,673	2,274	6,947	1,529	3,413	4,941	2,748	4,843	7,590	68,721	89,975	75,724

D. PROJECT TRIP DISTRIBUTION

A survey of warehouses in the Inland Empire³⁷ found that 80% of the vehicles entering or leaving warehouse sites are passenger cars, nearly all of which are used for commute trips by employees of the warehouses. The travel pattern of the project-related auto traffic is discussed below, followed by a discussion of project-related truck traffic.

WLC Auto Traffic

As discussed previously, Moreno Valley currently has a severe jobs/housing imbalance that results in long westbound commutes for thousands of city residents every workday. The WLC would create approximately 20,000 local job opportunities³⁸; nearly doubling the number of jobs in Moreno Valley. This would have several effects on commute patterns:

- Many current and future residents of Moreno Valley would have the opportunity to work locally with very short commute trips.
- Residents of neighboring cities who work at the WLC would have short commutes and, importantly, be able to access the site using the arterial road network. This is consistent with the

³⁶ Light trucks are 2 axle trucks with six wheels, medium trucks are those with three axles, and heavy trucks are those with four or more axles. Pickup trucks with four wheels are included in the “auto” category.

³⁷ *Truck Trip Generation Study*, City of Fontana, August 2003.

³⁸ Based on a ratio of 0.5 employees per 1000 square feet of logistics. This ratio is taken from: *DTA Public Works Database; confirmed by “Employment Density Study,” SCAG (2001), and “Logistics Trends and Specific Industries,” NAIOP Research Foundation (March 2010) San Bernardino Planning Department.*

policies of the Western Riverside Council of Governments and the Riverside County Transportation Commission to promote use of the arterial road network as an alternative to freeways. Tests with the RivTAM model (see Figure 39) suggest that nearly half of auto traffic associated with the WLC would be on surface streets; i.e. not on freeways.

- Workers coming from more distant locations would, in most cases, be travelling on freeways in the off-peak direction; i.e. commuters traveling to the WLC from Los Angeles or Orange Counties would be headed eastbound in the morning and westbound in the evening. This would enable them to take advantage of the existing unused off-peak capacity of freeways, since the freeways were sized for flows in the peak direction.
- Assuming, as RivTAM does, that WLC employees would work elsewhere if the WLC project were not implemented, then the availability of jobs at the east end of Moreno Valley would reduce the number of workers driving long commutes to distant jobsites to the west and southwest. Figure 40 shows that although the project would increase freeway auto traffic eastbound in the morning (where unused capacity is available), it would also decrease the traffic in the more congested westbound direction. In the evening the pattern would reverse, with the project relieving traffic in the congested eastbound direction (see Figure 41). Therefore, the WLC project would have a net beneficial impact on the regional freeway auto traffic. This is the effect sought in the policies of SCAG, WRCOG, and other regional governments and agencies that encourage better jobs/housing balances as a way to reduce peak directional flows on the regional freeway system.

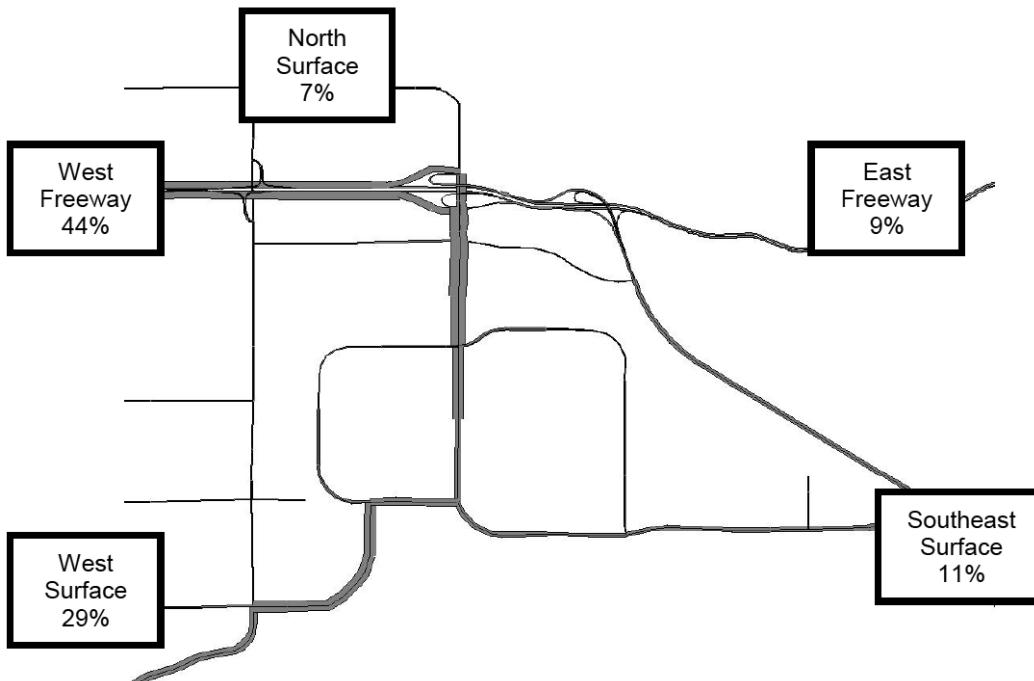

Figure 39: Daily Distribution of WLC Auto Trips

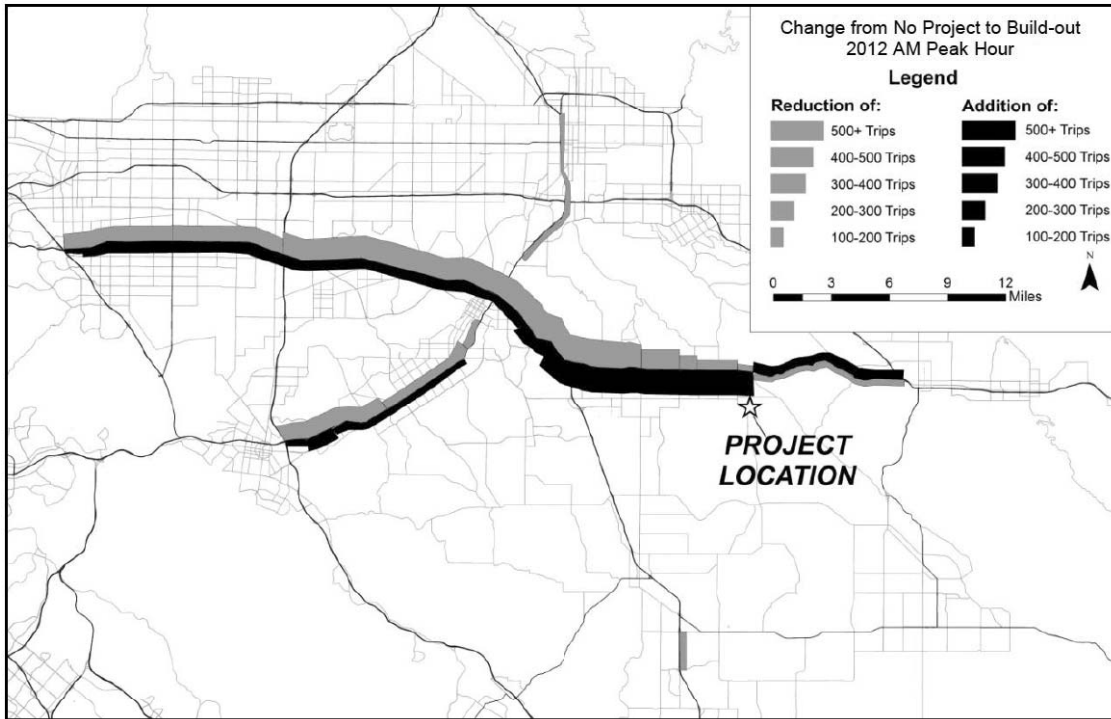

Figure 40: Effect of WLC on Freeway Car Traffic, AM Peak Hour 2012

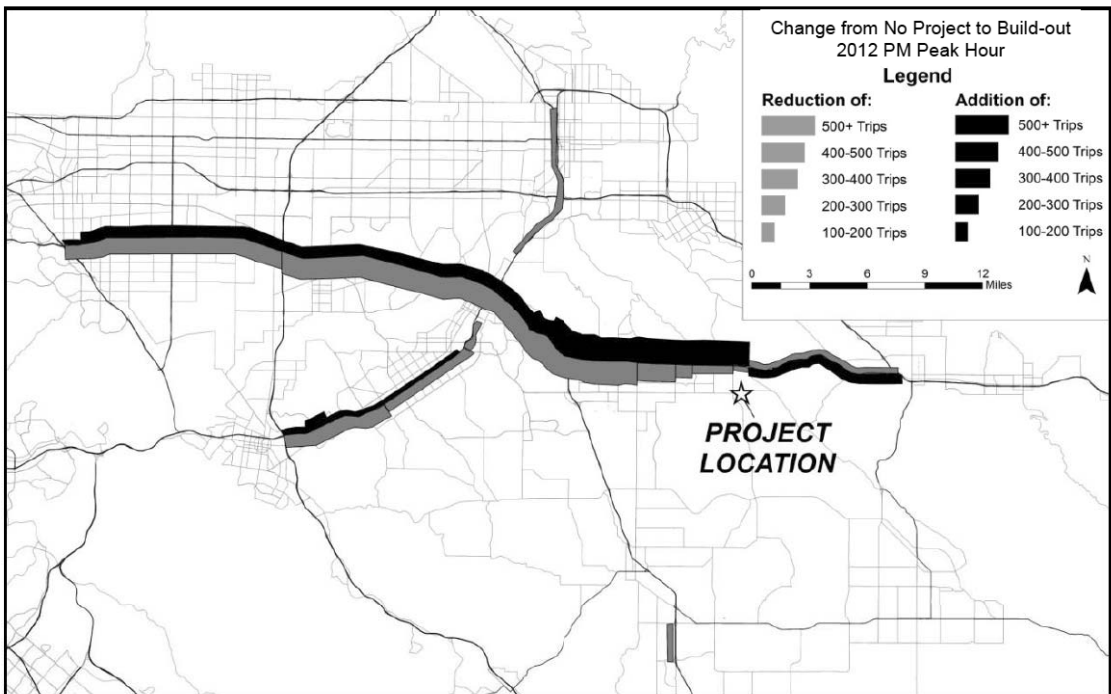

Figure 41: Effect of WLC on Freeway Car Traffic, PM Peak Hour 2012

WLC Truck Traffic

The truck traffic associated with a typical logistics center has a much different time-of-day pattern than auto traffic. Figure 42 shows the combined traffic data for vehicles entering or leaving the 31 logistics centers in 2011 NAIOP trip generation study. As shown, besides being much larger, the auto traffic shows distinct peaks while truck traffic is spread much more evenly throughout the 24-hour period. The five hours with the highest truck traffic all occurred outside of the freeway peak periods.

Some readers of the Draft TIA misunderstood Figure 42 to mean that the WLC traffic analysis did not cover the worst-case scenario. In fact, because of the conservatively high trip-generation rate used in the WLC analysis, along with the fact that the peak hour of trip generation for the WLC was assumed to occur simultaneous with the peak hour of background traffic, the assumptions in the WLC analysis are far more conservative (i.e. assume worse conditions) than the NAIOP survey would suggest is likely to occur (see Figure 43). In addition, the 2PM to 3PM hour was also studied with regards to possible impacts on pedestrians in the areas around schools, since most schools release students at that time of the day (see Chapter 12, Section B of this report).

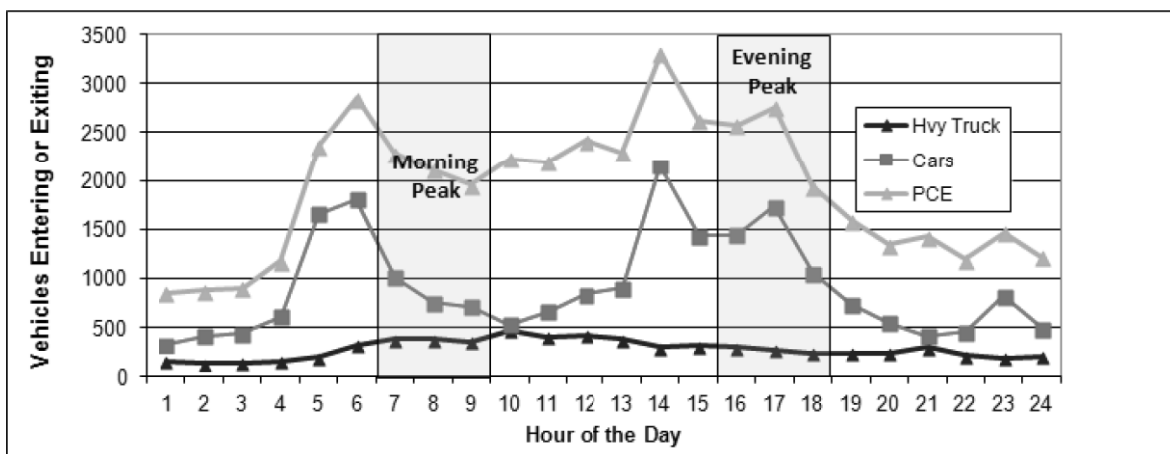

Figure 42: Time-of-Day Distribution of Traffic from Logistics Warehouses

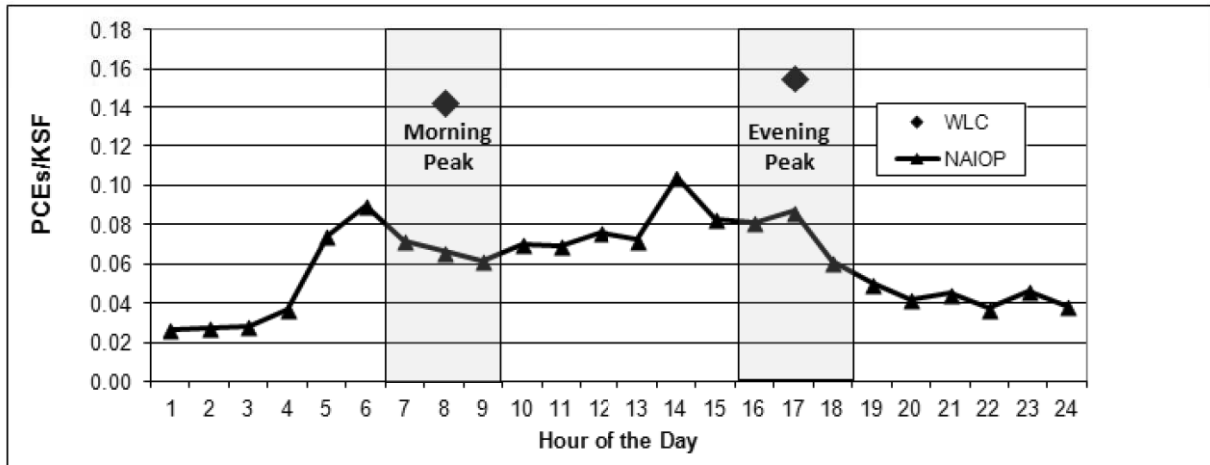

Figure 43: Time-of-Day Distribution, WLC Assumptions Compared to NAIOP

Since the internal trips, the port-related trips, and the majority of external trips (all but those on I-10) use routes west of the project site, it is anticipated that a large majority of the WLC truck traffic would be oriented to the west of the project, with a much smaller amount to and from the east. Also, due to truck routing restrictions the majority of WLC truck traffic would use the freeway system to enter and leave the site. However, there may be some trips between the WLC and local businesses, for example trip chaining among warehouses to consolidate cargos, that may use surface streets such as Gilman Springs Rd. Tests with the RivTAM model confirm this pattern (see Figure 44).

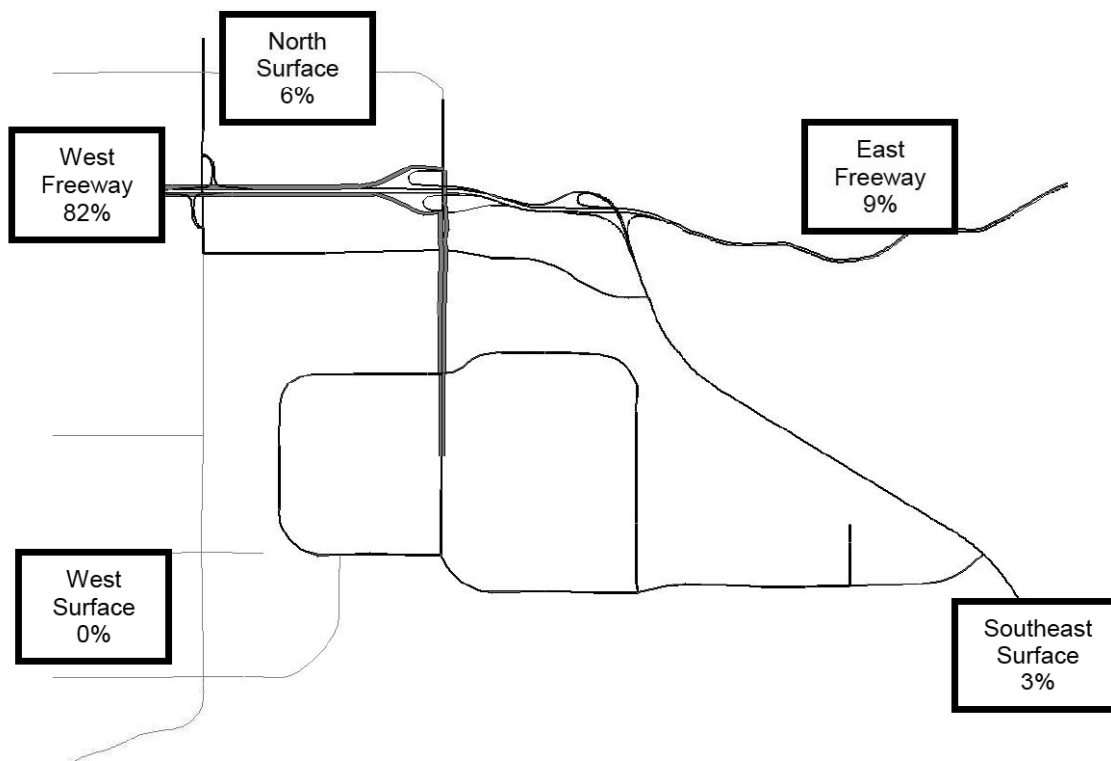

Figure 44: Daily Distribution of WLC Truck Trips

The percentage of WLC truck trips that would go to the port were estimated based on the assumptions described in Chapter 12 (see Table 87) for each study year. These percentages were then applied to the trip generation rates to find the number of WLC trucks going to and from the port in each analysis period. These are shown in Table 26. Tests with the SCAG traffic model showed that these trips would split approximately evenly between the two routes shown in Figure 56, so half of these trips were assigned to the SR-60 route and the other half assigned to the SR-91 route.

Table 26: WLC Truck Trips to and from the Port by Analysis Period

Scenario	AM Peak Hour		PM Peak Hour		Daily	
	In	Out	In	Out	In	Out
2012 Plus Build-out	18	10	14	17	121	121
2022 Plus Phase 1	19	11	15	18	127	127
2035 Plus Build-out	57	33	46	53	393	393

APPENDIX C

Traffic Count Worksheets

Counts Unlimited Inc
PO Box 1178
Corona, CA 92878
(951) 268-6268

City of Riverside
N/S: I-215 NB Ramps
E/W: Box Springs Road
Weather: Clear

File Name : RIV215NBRAM
Site Code : 06715392
Start Date : 7/7/2015
Page No : 1

Groups Printed- Passenger Vehicles - Large 2 Axle Vehicles - 3 Axle Vehicles - 4+ Axle Trucks

Start Time	215 NB Ramp Southbound				Box Springs Road Westbound				215 NB Ramp Northbound				Box Springs Road Eastbound				Int. Total
	Left	Thru	Right	App. Total	Left	Thru	Right	App. Total	Left	Thru	Right	App. Total	Left	Thru	Right	App. Total	
07:00 AM	0	0	0	0	0	91	161	252	17	5	0	22	88	25	0	113	387
07:15 AM	0	0	0	0	0	94	157	251	12	2	1	15	113	22	0	135	401
07:30 AM	0	0	0	0	0	102	201	303	14	2	0	16	123	28	0	151	470
07:45 AM	0	0	0	0	0	109	105	214	34	5	1	40	84	43	0	127	381
Total	0	0	0	0	0	396	624	1020	77	14	2	93	408	118	0	526	1639
08:00 AM	0	0	0	0	0	84	104	188	14	7	0	21	76	29	0	105	314
08:15 AM	0	0	0	0	0	62	101	163	43	5	0	48	86	39	0	125	336
08:30 AM	0	0	0	0	0	57	92	149	10	4	0	14	99	46	0	145	308
08:45 AM	0	0	0	0	0	42	67	109	18	1	0	19	88	40	0	128	256
Total	0	0	0	0	0	245	364	609	85	17	0	102	349	154	0	503	1214
Grand Total	0	0	0	0	0	641	988	1629	162	31	2	195	757	272	0	1029	2853
Apprch %	0	0	0	0	0	39.3	60.7		83.1	15.9	1		73.6	26.4	0		
Total %	0	0	0	0	0	22.5	34.6	57.1	5.7	1.1	0.1	6.8	26.5	9.5	0	36.1	
Passenger Vehicles	0	0	0	0	0	627	964	1591	157	31	2	190	652	259	0	911	2692
% Passenger Vehicles	0	0	0	0	0	97.8	97.6	97.7	96.9	100	100	97.4	86.1	95.2	0	88.5	94.4
Large 2 Axle Vehicles	0	0	0	0	0	11	18	29	5	0	0	5	29	12	0	41	75
% Large 2 Axle Vehicles	0	0	0	0	0	1.7	1.8	1.8	3.1	0	0	2.6	3.8	4.4	0	4	2.6
3 Axle Vehicles	0	0	0	0	0	0	0	0	0	0	0	0	5	0	0	5	5
% 3 Axle Vehicles	0	0	0	0	0	0	0	0	0	0	0	0	0.7	0	0	0.5	0.2
4+ Axle Trucks	0	0	0	0	0	3	6	9	0	0	0	0	71	1	0	72	81
% 4+ Axle Trucks	0	0	0	0	0	0.5	0.6	0.6	0	0	0	0	9.4	0.4	0	7	2.8

Start Time	215 NB Ramp Southbound				Box Springs Road Westbound				215 NB Ramp Northbound				Box Springs Road Eastbound				Int. Total
	Left	Thru	Right	App. Total	Left	Thru	Right	App. Total	Left	Thru	Right	App. Total	Left	Thru	Right	App. Total	
Peak Hour Analysis From 07:00 AM to 08:45 AM - Peak 1 of 1																	
Peak Hour for Entire Intersection Begins at 07:00 AM																	
07:00 AM	0	0	0	0	0	91	161	252	17	5	0	22	88	25	0	113	387
07:15 AM	0	0	0	0	0	94	157	251	12	2	1	15	113	22	0	135	401
07:30 AM	0	0	0	0	0	102	201	303	14	2	0	16	123	28	0	151	470
07:45 AM	0	0	0	0	0	109	105	214	34	5	1	40	84	43	0	127	381
Total Volume	0	0	0	0	0	396	624	1020	77	14	2	93	408	118	0	526	1639
% App. Total	0	0	0	0	0	38.8	61.2		82.8	15.1	2.2		77.6	22.4	0		
PHF	.000	.000	.000	.000	.000	.908	.776	.842	.566	.700	.500	.581	.829	.686	.000	.871	.872

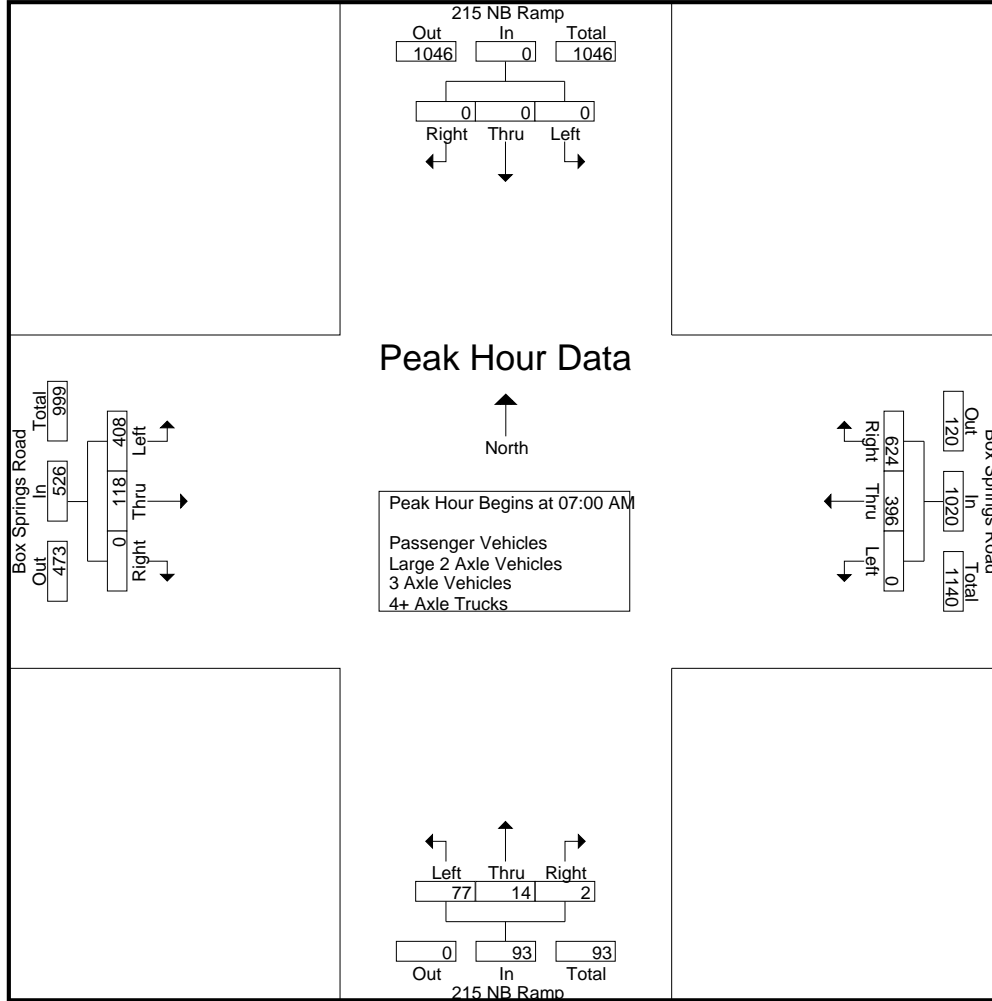

Peak Hour Analysis From 07:00 AM to 08:45 AM - Peak 1 of 1
 Peak Hour for Each Approach Begins at:

	07:00 AM				07:00 AM				07:30 AM				07:00 AM			
+0 mins.	0	0	0	0	0	91	161	252	14	2	0	16	88	25	0	113
+15 mins.	0	0	0	0	0	94	157	251	34	5	1	40	113	22	0	135
+30 mins.	0	0	0	0	0	102	201	303	14	7	0	21	123	28	0	151
+45 mins.	0	0	0	0	0	109	105	214	43	5	0	48	84	43	0	127
Total Volume	0	0	0	0	0	396	624	1020	105	19	1	125	408	118	0	526
% App. Total	0	0	0	0	0	38.8	61.2		84	15.2	0.8		77.6	22.4	0	
PHF	.000	.000	.000	.000	.000	.908	.776	.842	.610	.679	.250	.651	.829	.686	.000	.871

Counts Unlimited Inc
 PO Box 1178
 Corona, CA 92878
 (951) 268-6268

City of Riverside
 N/S: I-215 NB Ramps
 E/W: Box Springs Road
 Weather: Clear

File Name : RIV215NBRAM
 Site Code : 06715392
 Start Date : 7/7/2015
 Page No : 1

Groups Printed- Passenger Vehicles

Start Time	215 NB Ramp Southbound				Box Springs Road Westbound				215 NB Ramp Northbound				Box Springs Road Eastbound				Int. Total
	Left	Thru	Right	App. Total	Left	Thru	Right	App. Total	Left	Thru	Right	App. Total	Left	Thru	Right	App. Total	
07:00 AM	0	0	0	0	0	91	158	249	17	5	0	22	72	24	0	96	367
07:15 AM	0	0	0	0	0	93	155	248	10	2	1	13	102	22	0	124	385
07:30 AM	0	0	0	0	0	96	194	290	14	2	0	16	106	27	0	133	439
07:45 AM	0	0	0	0	0	107	104	211	33	5	1	39	71	42	0	113	363
Total	0	0	0	0	0	387	611	998	74	14	2	90	351	115	0	466	1554
08:00 AM	0	0	0	0	0	82	99	181	13	7	0	20	60	27	0	87	288
08:15 AM	0	0	0	0	0	62	99	161	42	5	0	47	71	34	0	105	313
08:30 AM	0	0	0	0	0	55	89	144	10	4	0	14	84	44	0	128	286
08:45 AM	0	0	0	0	0	41	66	107	18	1	0	19	86	39	0	125	251
Total	0	0	0	0	0	240	353	593	83	17	0	100	301	144	0	445	1138
Grand Total	0	0	0	0	0	627	964	1591	157	31	2	190	652	259	0	911	2692
Apprch %	0	0	0		0	39.4	60.6		82.6	16.3	1.1		71.6	28.4	0		
Total %	0	0	0		0	23.3	35.8	59.1	5.8	1.2	0.1	7.1	24.2	9.6	0	33.8	

Start Time	215 NB Ramp Southbound				Box Springs Road Westbound				215 NB Ramp Northbound				Box Springs Road Eastbound				Int. Total
	Left	Thru	Right	App. Total	Left	Thru	Right	App. Total	Left	Thru	Right	App. Total	Left	Thru	Right	App. Total	
Peak Hour Analysis From 07:00 AM to 07:45 AM - Peak 1 of 1																	
Peak Hour for Entire Intersection Begins at 07:00 AM																	
07:00 AM	0	0	0	0	0	91	158	249	17	5	0	22	72	24	0	96	367
07:15 AM	0	0	0	0	0	93	155	248	10	2	1	13	102	22	0	124	385
07:30 AM	0	0	0	0	0	96	194	290	14	2	0	16	106	27	0	133	439
07:45 AM	0	0	0	0	0	107	104	211	33	5	1	39	71	42	0	113	363
Total Volume	0	0	0	0	0	387	611	998	74	14	2	90	351	115	0	466	1554
% App. Total	0	0	0		0	38.8	61.2		82.2	15.6	2.2		75.3	24.7	0		
PHF	.000	.000	.000	.000	.000	.904	.787	.860	.561	.700	.500	.577	.828	.685	.000	.876	.885

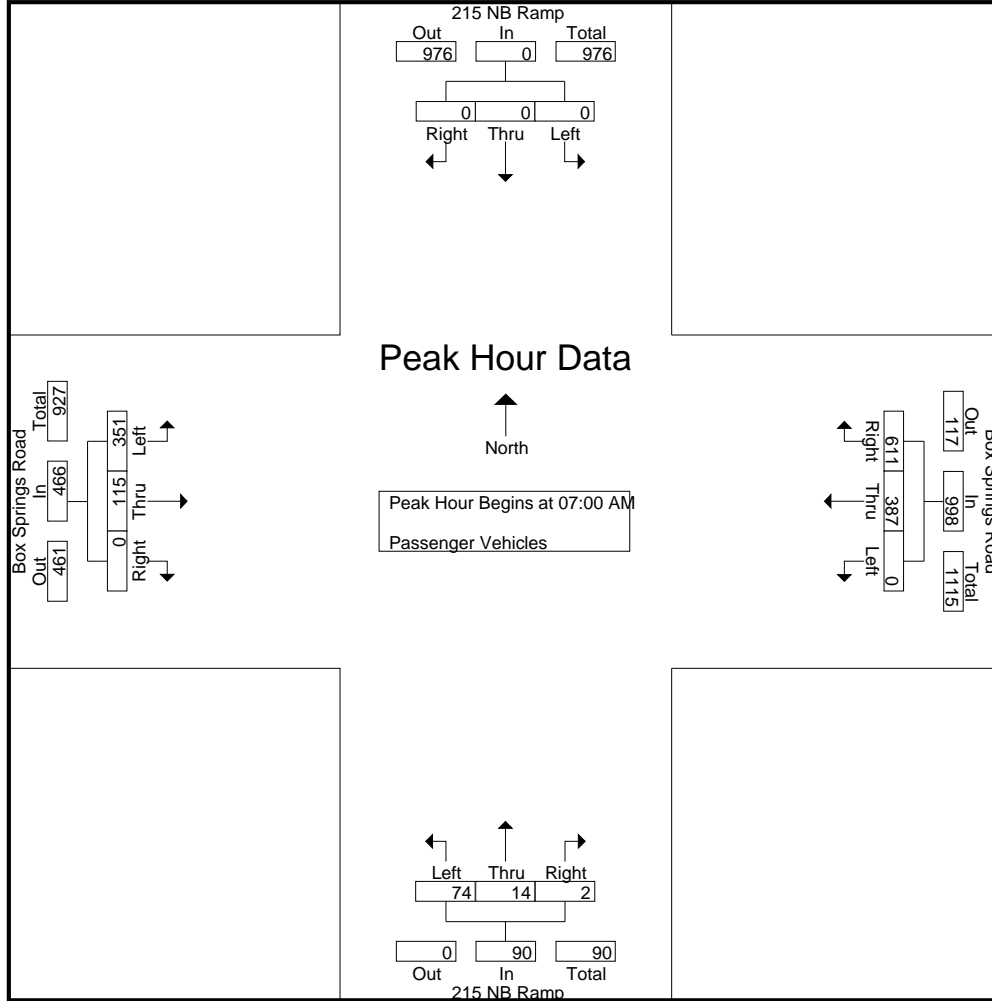

Peak Hour Analysis From 07:00 AM to 07:45 AM - Peak 1 of 1
 Peak Hour for Each Approach Begins at:

	07:00 AM				07:00 AM				07:00 AM				07:00 AM			
+0 mins.	0	0	0	0	0	91	158	249	17	5	0	22	72	24	0	96
+15 mins.	0	0	0	0	0	93	155	248	10	2	1	13	102	22	0	124
+30 mins.	0	0	0	0	0	96	194	290	14	2	0	16	106	27	0	133
+45 mins.	0	0	0	0	0	107	104	211	33	5	1	39	71	42	0	113
Total Volume	0	0	0	0	0	387	611	998	74	14	2	90	351	115	0	466
% App. Total	0	0	0	0	0	38.8	61.2		82.2	15.6	2.2		75.3	24.7	0	
PHF	.000	.000	.000	.000	.000	.904	.787	.860	.561	.700	.500	.577	.828	.685	.000	.876

Counts Unlimited Inc
PO Box 1178
Corona, CA 92878
(951) 268-6268

City of Riverside
N/S: I-215 NB Ramps
E/W: Box Springs Road
Weather: Clear

File Name : RIV215NBRAM
Site Code : 06715392
Start Date : 7/7/2015
Page No : 1

Groups Printed- Large 2 Axle Vehicles

Start Time	215 NB Ramp Southbound				Box Springs Road Westbound				215 NB Ramp Northbound				Box Springs Road Eastbound				Int. Total
	Left	Thru	Right	App. Total	Left	Thru	Right	App. Total	Left	Thru	Right	App. Total	Left	Thru	Right	App. Total	
07:00 AM	0	0	0	0	0	0	3	3	0	0	0	0	5	1	0	6	9
07:15 AM	0	0	0	0	0	1	2	3	2	0	0	2	2	0	0	2	7
07:30 AM	0	0	0	0	0	3	5	8	0	0	0	0	5	1	0	6	14
07:45 AM	0	0	0	0	0	2	0	2	1	0	0	1	2	1	0	3	6
Total	0	0	0	0	0	6	10	16	3	0	0	3	14	3	0	17	36
08:00 AM	0	0	0	0	0	2	2	4	1	0	0	1	3	2	0	5	10
08:15 AM	0	0	0	0	0	0	2	2	1	0	0	1	5	5	0	10	13
08:30 AM	0	0	0	0	0	2	3	5	0	0	0	0	5	2	0	7	12
08:45 AM	0	0	0	0	0	1	1	2	0	0	0	0	2	0	0	2	4
Total	0	0	0	0	0	5	8	13	2	0	0	2	15	9	0	24	39
Grand Total	0	0	0	0	0	11	18	29	5	0	0	5	29	12	0	41	75
Apprch %	0	0	0		0	37.9	62.1		100	0	0		70.7	29.3	0		
Total %	0	0	0		0	14.7	24	38.7	6.7	0	0	6.7	38.7	16	0	54.7	

Start Time	215 NB Ramp Southbound				Box Springs Road Westbound				215 NB Ramp Northbound				Box Springs Road Eastbound				Int. Total
	Left	Thru	Right	App. Total	Left	Thru	Right	App. Total	Left	Thru	Right	App. Total	Left	Thru	Right	App. Total	
Peak Hour Analysis From 07:00 AM to 07:45 AM - Peak 1 of 1																	
Peak Hour for Entire Intersection Begins at 07:00 AM																	
07:00 AM	0	0	0	0	0	0	3	3	0	0	0	0	5	1	0	6	9
07:15 AM	0	0	0	0	0	1	2	3	2	0	0	2	2	0	0	2	7
07:30 AM	0	0	0	0	0	3	5	8	0	0	0	0	5	1	0	6	14
07:45 AM	0	0	0	0	0	2	0	2	1	0	0	1	2	1	0	3	6
Total Volume	0	0	0	0	0	6	10	16	3	0	0	3	14	3	0	17	36
% App. Total	0	0	0		0	37.5	62.5		100	0	0		82.4	17.6	0		
PHF	.000	.000	.000	.000	.000	.500	.500	.500	.375	.000	.000	.375	.700	.750	.000	.708	.643

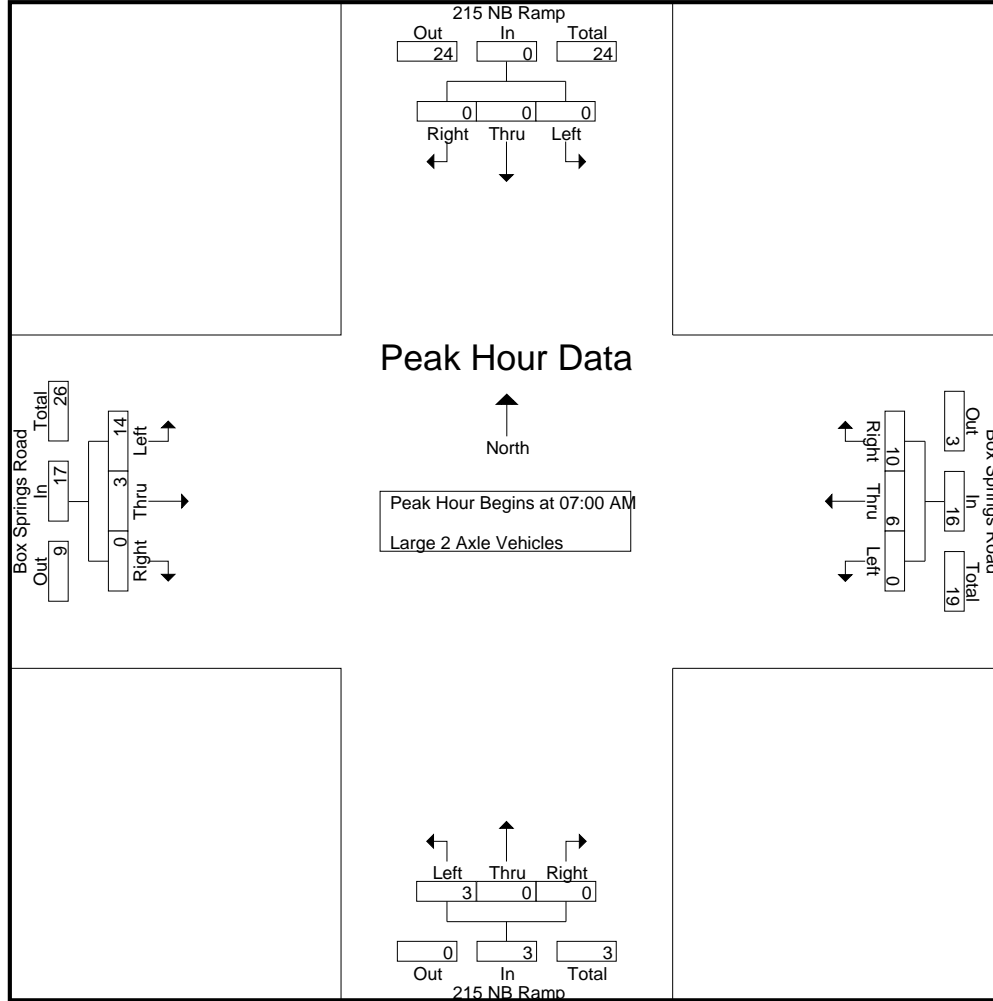

Peak Hour Analysis From 07:00 AM to 07:45 AM - Peak 1 of 1
 Peak Hour for Each Approach Begins at:

	07:00 AM				07:00 AM				07:00 AM				07:00 AM			
+0 mins.	0	0	0	0	0	0	3	3	0	0	0	0	5	1	0	6
+15 mins.	0	0	0	0	0	1	2	3	2	0	0	2	2	0	0	2
+30 mins.	0	0	0	0	0	3	5	8	0	0	0	0	5	1	0	6
+45 mins.	0	0	0	0	0	2	0	2	1	0	0	1	2	1	0	3
Total Volume	0	0	0	0	0	6	10	16	3	0	0	3	14	3	0	17
% App. Total	0	0	0	0	0	37.5	62.5		100	0	0		82.4	17.6	0	
PHF	.000	.000	.000	.000	.000	.500	.500	.500	.375	.000	.000	.375	.700	.750	.000	.708

Counts Unlimited Inc
 PO Box 1178
 Corona, CA 92878
 (951) 268-6268

City of Riverside
 N/S: I-215 NB Ramps
 E/W: Box Springs Road
 Weather: Clear

File Name : RIV215NBRAM
 Site Code : 06715392
 Start Date : 7/7/2015
 Page No : 1

Groups Printed- 3 Axle Vehicles

Start Time	215 NB Ramp Southbound				Box Springs Road Westbound				215 NB Ramp Northbound				Box Springs Road Eastbound				Int. Total
	Left	Thru	Right	App. Total	Left	Thru	Right	App. Total	Left	Thru	Right	App. Total	Left	Thru	Right	App. Total	
07:00 AM	0	0	0	0	0	0	0	0	0	0	0	0	1	0	0	1	1
07:15 AM	0	0	0	0	0	0	0	0	0	0	0	0	1	0	0	1	1
07:30 AM	0	0	0	0	0	0	0	0	0	0	0	0	0	0	0	0	0
07:45 AM	0	0	0	0	0	0	0	0	0	0	0	0	1	0	0	1	1
Total	0	0	0	0	0	0	0	0	0	0	0	0	3	0	0	3	3
08:00 AM	0	0	0	0	0	0	0	0	0	0	0	0	1	0	0	1	1
08:15 AM	0	0	0	0	0	0	0	0	0	0	0	0	0	0	0	0	0
08:30 AM	0	0	0	0	0	0	0	0	0	0	0	0	1	0	0	1	1
08:45 AM	0	0	0	0	0	0	0	0	0	0	0	0	0	0	0	0	0
Total	0	0	0	0	0	0	0	0	0	0	0	0	2	0	0	2	2
Grand Total	0	0	0	0	0	0	0	0	0	0	0	0	5	0	0	5	5
Apprch %	0	0	0		0	0	0		0	0	0		100	0	0		
Total %	0	0	0		0	0	0		0	0	0		100	0	0	100	

Start Time	215 NB Ramp Southbound				Box Springs Road Westbound				215 NB Ramp Northbound				Box Springs Road Eastbound				Int. Total
	Left	Thru	Right	App. Total	Left	Thru	Right	App. Total	Left	Thru	Right	App. Total	Left	Thru	Right	App. Total	
Peak Hour Analysis From 07:00 AM to 07:45 AM - Peak 1 of 1																	
Peak Hour for Entire Intersection Begins at 07:00 AM																	
07:00 AM	0	0	0	0	0	0	0	0	0	0	0	0	1	0	0	1	1
07:15 AM	0	0	0	0	0	0	0	0	0	0	0	0	1	0	0	1	1
07:30 AM	0	0	0	0	0	0	0	0	0	0	0	0	0	0	0	0	0
07:45 AM	0	0	0	0	0	0	0	0	0	0	0	0	1	0	0	1	1
Total Volume	0	0	0	0	0	0	0	0	0	0	0	0	3	0	0	3	3
% App. Total	0	0	0		0	0	0		0	0	0		100	0	0		
PHF	.000	.000	.000	.000	.000	.000	.000	.000	.000	.000	.000	.000	.750	.000	.000	.750	.750

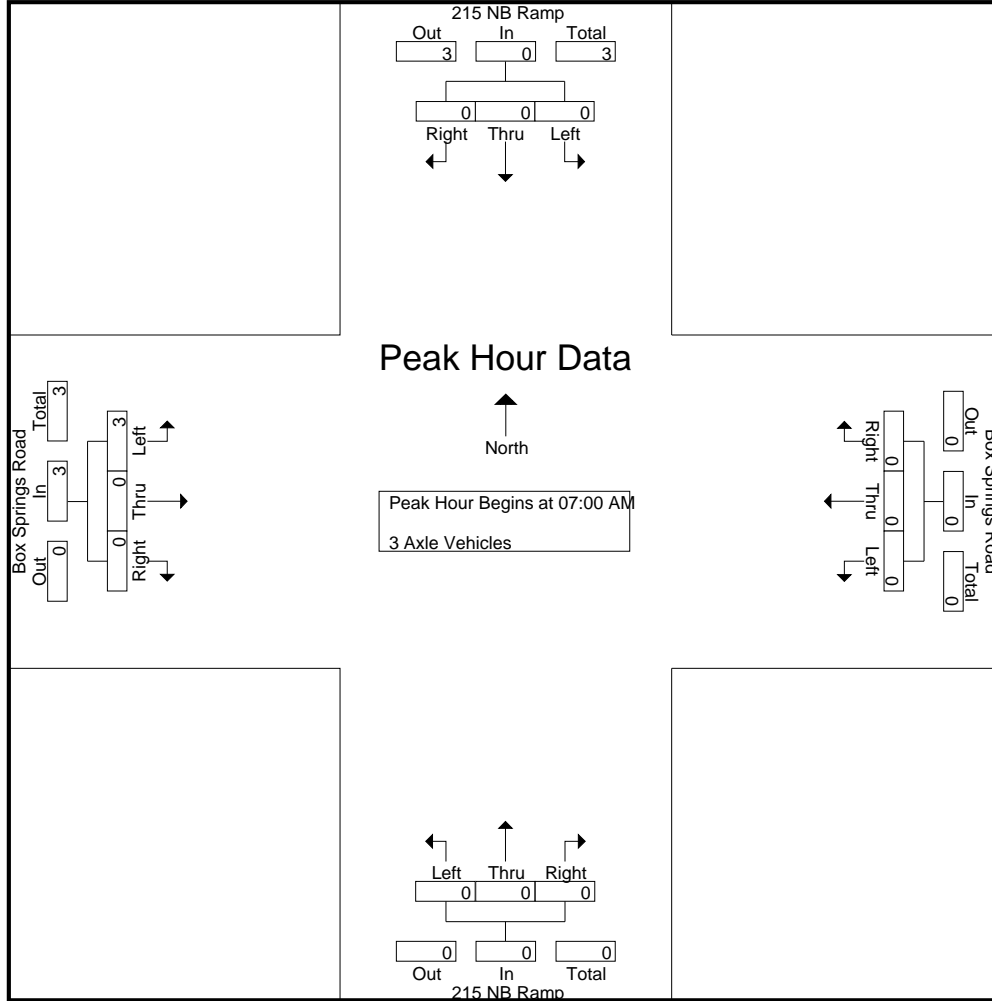

Peak Hour Analysis From 07:00 AM to 07:45 AM - Peak 1 of 1
 Peak Hour for Each Approach Begins at:

	07:00 AM				07:00 AM				07:00 AM				07:00 AM			
+0 mins.	0	0	0	0	0	0	0	0	0	0	0	0	1	0	0	1
+15 mins.	0	0	0	0	0	0	0	0	0	0	0	0	1	0	0	1
+30 mins.	0	0	0	0	0	0	0	0	0	0	0	0	0	0	0	0
+45 mins.	0	0	0	0	0	0	0	0	0	0	0	0	1	0	0	1
Total Volume	0	0	0	0	0	0	0	0	0	0	0	0	3	0	0	3
% App. Total	0	0	0	0	0	0	0	0	0	0	0	0	100	0	0	0
PHF	.000	.000	.000	.000	.000	.000	.000	.000	.000	.000	.000	.000	.750	.000	.000	.750

Counts Unlimited Inc
PO Box 1178
Corona, CA 92878
(951) 268-6268

City of Riverside
N/S: I-215 NB Ramps
E/W: Box Springs Road
Weather: Clear

File Name : RIV215NBRAM
Site Code : 06715392
Start Date : 7/7/2015
Page No : 1

Groups Printed- 4+ Axle Trucks

Start Time	215 NB Ramp Southbound				Box Springs Road Westbound				215 NB Ramp Northbound				Box Springs Road Eastbound				Int. Total
	Left	Thru	Right	App. Total	Left	Thru	Right	App. Total	Left	Thru	Right	App. Total	Left	Thru	Right	App. Total	
07:00 AM	0	0	0	0	0	0	0	0	0	0	0	0	10	0	0	10	10
07:15 AM	0	0	0	0	0	0	0	0	0	0	0	0	8	0	0	8	8
07:30 AM	0	0	0	0	0	3	2	5	0	0	0	0	12	0	0	12	17
07:45 AM	0	0	0	0	0	0	1	1	0	0	0	0	10	0	0	10	11
Total	0	0	0	0	0	3	3	6	0	0	0	0	40	0	0	40	46
08:00 AM	0	0	0	0	0	0	3	3	0	0	0	0	12	0	0	12	15
08:15 AM	0	0	0	0	0	0	0	0	0	0	0	0	10	0	0	10	10
08:30 AM	0	0	0	0	0	0	0	0	0	0	0	0	9	0	0	9	9
08:45 AM	0	0	0	0	0	0	0	0	0	0	0	0	0	1	0	1	1
Total	0	0	0	0	0	0	3	3	0	0	0	0	31	1	0	32	35
Grand Total	0	0	0	0	0	3	6	9	0	0	0	0	71	1	0	72	81
Apprch %	0	0	0		0	33.3	66.7		0	0	0		98.6	1.4	0		
Total %	0	0	0		0	3.7	7.4	11.1	0	0	0		87.7	1.2	0	88.9	

Start Time	215 NB Ramp Southbound				Box Springs Road Westbound				215 NB Ramp Northbound				Box Springs Road Eastbound				Int. Total
	Left	Thru	Right	App. Total	Left	Thru	Right	App. Total	Left	Thru	Right	App. Total	Left	Thru	Right	App. Total	
Peak Hour Analysis From 07:00 AM to 07:45 AM - Peak 1 of 1																	
Peak Hour for Entire Intersection Begins at 07:00 AM																	
07:00 AM	0	0	0	0	0	0	0	0	0	0	0	0	10	0	0	10	10
07:15 AM	0	0	0	0	0	0	0	0	0	0	0	0	8	0	0	8	8
07:30 AM	0	0	0	0	0	3	2	5	0	0	0	0	12	0	0	12	17
07:45 AM	0	0	0	0	0	0	1	1	0	0	0	0	10	0	0	10	11
Total Volume	0	0	0	0	0	3	3	6	0	0	0	0	40	0	0	40	46
% App. Total	0	0	0		0	50	50		0	0	0		100	0	0		
PHF	.000	.000	.000	.000	.000	.250	.375	.300	.000	.000	.000	.000	.833	.000	.000	.833	.676

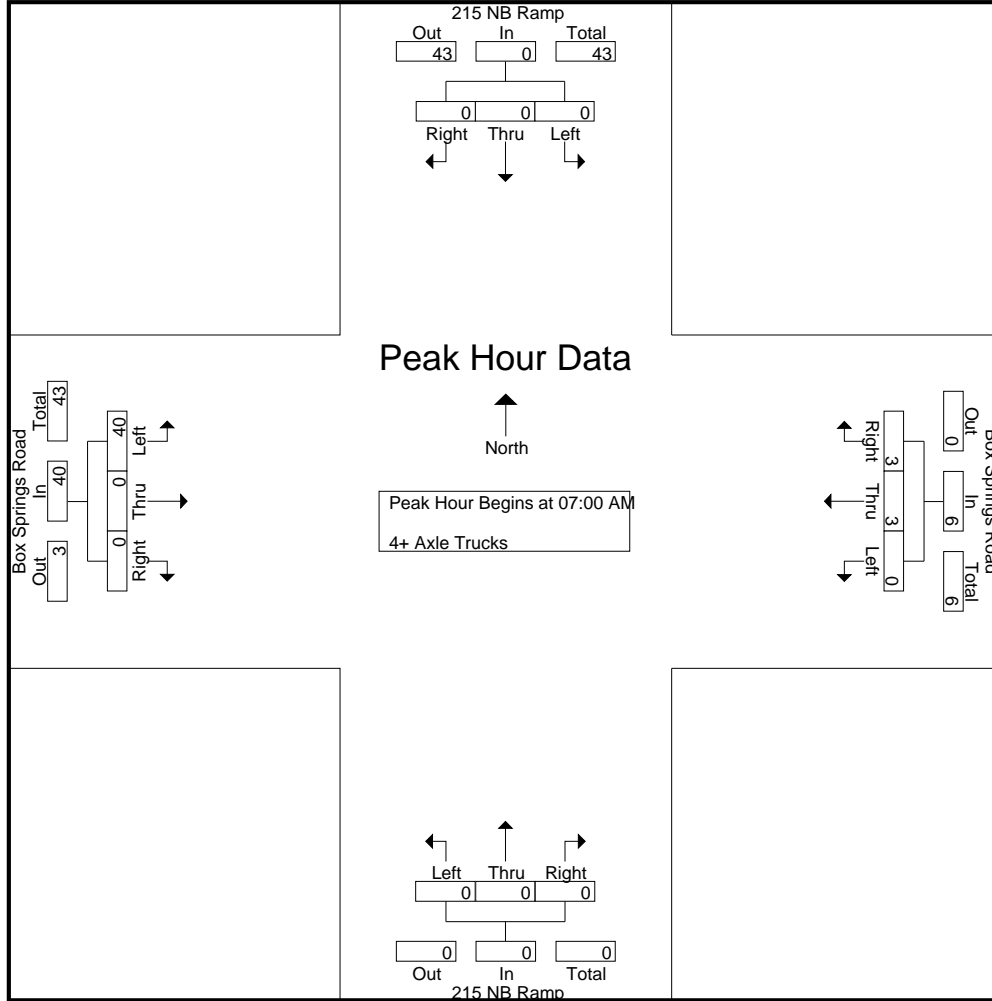

Peak Hour Analysis From 07:00 AM to 07:45 AM - Peak 1 of 1
 Peak Hour for Each Approach Begins at:

	07:00 AM				07:00 AM				07:00 AM				07:00 AM			
+0 mins.	0	0	0	0	0	0	0	0	0	0	0	0	10	0	0	10
+15 mins.	0	0	0	0	0	0	0	0	0	0	0	0	8	0	0	8
+30 mins.	0	0	0	0	0	3	2	5	0	0	0	0	12	0	0	12
+45 mins.	0	0	0	0	0	0	1	1	0	0	0	0	10	0	0	10
Total Volume	0	0	0	0	0	3	3	6	0	0	0	0	40	0	0	40
% App. Total	0	0	0	0	0	50	50	300	0	0	0	0	100	0	0	833
PHF	.000	.000	.000	.000	.000	.250	.375	.300	.000	.000	.000	.000	.833	.000	.000	.833

Counts Unlimited Inc
 PO Box 1178
 Corona, CA 92878
 (951) 268-6268

City of Riverside
 N/S: I-215 NB Ramps
 E/W: Box Springs Road
 Weather: Clear

File Name : RIV215NBRPM
 Site Code : 06715392
 Start Date : 7/7/2015
 Page No : 1

Groups Printed- Passenger Vehicles - Large 2 Axle Vehicles - 3 Axle Vehicles - 4+ Axle Trucks

Start Time	215 NB Ramp Southbound				Box Springs Road Westbound				215 NB Ramp Northbound				Box Springs Road Eastbound				Int. Total
	Left	Thru	Right	App. Total	Left	Thru	Right	App. Total	Left	Thru	Right	App. Total	Left	Thru	Right	App. Total	
04:00 PM	0	0	0	0	0	39	48	87	12	0	0	12	101	91	0	192	291
04:15 PM	0	0	0	0	0	25	59	84	15	0	0	15	73	118	0	191	290
04:30 PM	0	0	0	0	0	33	45	78	30	0	2	32	113	111	0	224	334
04:45 PM	0	0	0	0	0	30	59	89	11	0	0	11	64	122	0	186	286
Total	0	0	0	0	0	127	211	338	68	0	2	70	351	442	0	793	1201
05:00 PM	0	0	0	0	0	46	67	113	19	0	0	19	139	103	0	242	374
05:15 PM	0	0	0	0	0	31	61	92	18	2	1	21	97	161	0	258	371
05:30 PM	0	0	0	0	0	42	64	106	22	1	2	25	68	164	0	232	363
05:45 PM	0	0	0	0	0	33	65	98	16	2	0	18	53	166	0	219	335
Total	0	0	0	0	0	152	257	409	75	5	3	83	357	594	0	951	1443
Grand Total	0	0	0	0	0	279	468	747	143	5	5	153	708	1036	0	1744	2644
Apprch %	0	0	0		0	37.3	62.7		93.5	3.3	3.3		40.6	59.4	0		
Total %	0	0	0		0	10.6	17.7	28.3	5.4	0.2	0.2	5.8	26.8	39.2	0	66	
Passenger Vehicles	0	0	0	0	0	271	462	733	136	5	5	146	649	1020	0	1669	2548
% Passenger Vehicles	0	0	0	0	0	97.1	98.7	98.1	95.1	100	100	95.4	91.7	98.5	0	95.7	96.4
Large 2 Axle Vehicles	0	0	0	0	0	8	6	14	7	0	0	7	19	16	0	35	56
% Large 2 Axle Vehicles	0	0	0	0	0	2.9	1.3	1.9	4.9	0	0	4.6	2.7	1.5	0	2	2.1
3 Axle Vehicles	0	0	0	0	0	0	0	0	0	0	0	0	7	0	0	7	7
% 3 Axle Vehicles	0	0	0	0	0	0	0	0	0	0	0	0	1	0	0	0.4	0.3
4+ Axle Trucks	0	0	0	0	0	0	0	0	0	0	0	0	33	0	0	33	33
% 4+ Axle Trucks	0	0	0	0	0	0	0	0	0	0	0	0	4.7	0	0	1.9	1.2

Start Time	215 NB Ramp Southbound				Box Springs Road Westbound				215 NB Ramp Northbound				Box Springs Road Eastbound				Int. Total
	Left	Thru	Right	App. Total	Left	Thru	Right	App. Total	Left	Thru	Right	App. Total	Left	Thru	Right	App. Total	
Peak Hour Analysis From 04:00 PM to 05:45 PM - Peak 1 of 1																	
Peak Hour for Entire Intersection Begins at 05:00 PM																	
05:00 PM	0	0	0	0	0	46	67	113	19	0	0	19	139	103	0	242	374
05:15 PM	0	0	0	0	0	31	61	92	18	2	1	21	97	161	0	258	371
05:30 PM	0	0	0	0	0	42	64	106	22	1	2	25	68	164	0	232	363
05:45 PM	0	0	0	0	0	33	65	98	16	2	0	18	53	166	0	219	335
Total Volume	0	0	0	0	0	152	257	409	75	5	3	83	357	594	0	951	1443
% App. Total	0	0	0		0	37.2	62.8		90.4	6	3.6		37.5	62.5	0		
PHF	.000	.000	.000	.000	.000	.826	.959	.905	.852	.625	.375	.830	.642	.895	.000	.922	.965

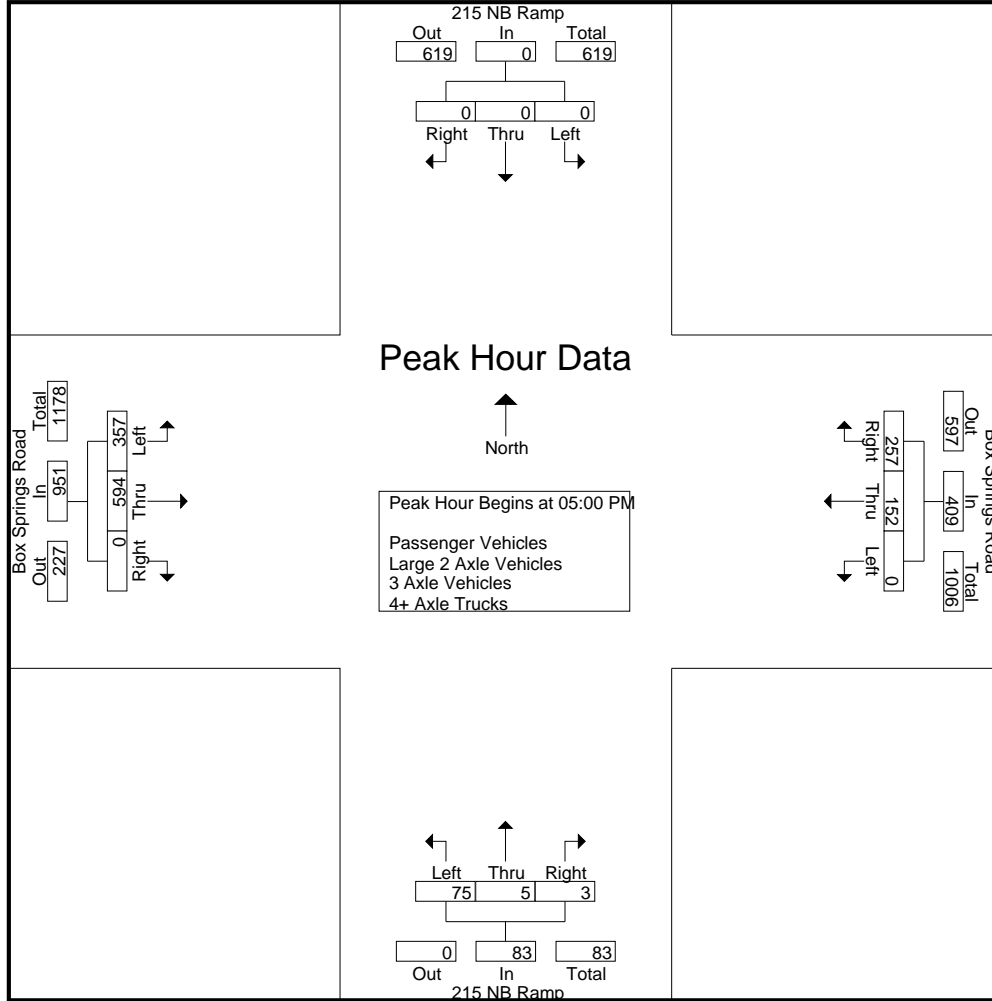

Peak Hour Analysis From 04:00 PM to 05:45 PM - Peak 1 of 1
 Peak Hour for Each Approach Begins at:

	04:00 PM				05:00 PM				04:30 PM				05:00 PM			
+0 mins.	0	0	0	0	0	46	67	113	30	0	2	32	139	103	0	242
+15 mins.	0	0	0	0	0	31	61	92	11	0	0	11	97	161	0	258
+30 mins.	0	0	0	0	0	42	64	106	19	0	0	19	68	164	0	232
+45 mins.	0	0	0	0	0	33	65	98	18	2	1	21	53	166	0	219
Total Volume	0	0	0	0	0	152	257	409	78	2	3	83	357	594	0	951
% App. Total	0	0	0	0	0	37.2	62.8		94	2.4	3.6		37.5	62.5	0	
PHF	.000	.000	.000	.000	.000	.826	.959	.905	.650	.250	.375	.648	.642	.895	.000	.922

Counts Unlimited Inc
PO Box 1178
Corona, CA 92878
(951) 268-6268

City of Riverside
N/S: I-215 NB Ramps
E/W: Box Springs Road
Weather: Clear

File Name : RIV215NBRPM
Site Code : 06715392
Start Date : 7/7/2015
Page No : 1

Groups Printed- Passenger Vehicles

Start Time	215 NB Ramp Southbound				Box Springs Road Westbound				215 NB Ramp Northbound				Box Springs Road Eastbound				Int. Total
	Left	Thru	Right	App. Total	Left	Thru	Right	App. Total	Left	Thru	Right	App. Total	Left	Thru	Right	App. Total	
04:00 PM	0	0	0	0	0	39	47	86	12	0	0	12	90	89	0	179	277
04:15 PM	0	0	0	0	0	23	58	81	13	0	0	13	63	117	0	180	274
04:30 PM	0	0	0	0	0	32	45	77	29	0	2	31	109	109	0	218	326
04:45 PM	0	0	0	0	0	30	58	88	9	0	0	9	57	121	0	178	275
Total	0	0	0	0	0	124	208	332	63	0	2	65	319	436	0	755	1152
05:00 PM	0	0	0	0	0	45	65	110	19	0	0	19	131	98	0	229	358
05:15 PM	0	0	0	0	0	29	60	89	17	2	1	20	88	158	0	246	355
05:30 PM	0	0	0	0	0	42	64	106	21	1	2	24	62	164	0	226	356
05:45 PM	0	0	0	0	0	31	65	96	16	2	0	18	49	164	0	213	327
Total	0	0	0	0	0	147	254	401	73	5	3	81	330	584	0	914	1396
Grand Total	0	0	0	0	0	271	462	733	136	5	5	146	649	1020	0	1669	2548
Apprch %	0	0	0	0	0	37	63		93.2	3.4	3.4		38.9	61.1	0		
Total %	0	0	0	0	0	10.6	18.1	28.8	5.3	0.2	0.2	5.7	25.5	40	0	65.5	

Start Time	215 NB Ramp Southbound				Box Springs Road Westbound				215 NB Ramp Northbound				Box Springs Road Eastbound				Int. Total
	Left	Thru	Right	App. Total	Left	Thru	Right	App. Total	Left	Thru	Right	App. Total	Left	Thru	Right	App. Total	
Peak Hour Analysis From 05:00 PM to 05:45 PM - Peak 1 of 1																	
Peak Hour for Entire Intersection Begins at 05:00 PM																	
05:00 PM	0	0	0	0	0	45	65	110	19	0	0	19	131	98	0	229	358
05:15 PM	0	0	0	0	0	29	60	89	17	2	1	20	88	158	0	246	355
05:30 PM	0	0	0	0	0	42	64	106	21	1	2	24	62	164	0	226	356
05:45 PM	0	0	0	0	0	31	65	96	16	2	0	18	49	164	0	213	327
Total Volume	0	0	0	0	0	147	254	401	73	5	3	81	330	584	0	914	1396
% App. Total	0	0	0	0	0	36.7	63.3		90.1	6.2	3.7		36.1	63.9	0		
PHF	.000	.000	.000	.000	.000	.817	.977	.911	.869	.625	.375	.844	.630	.890	.000	.929	.975

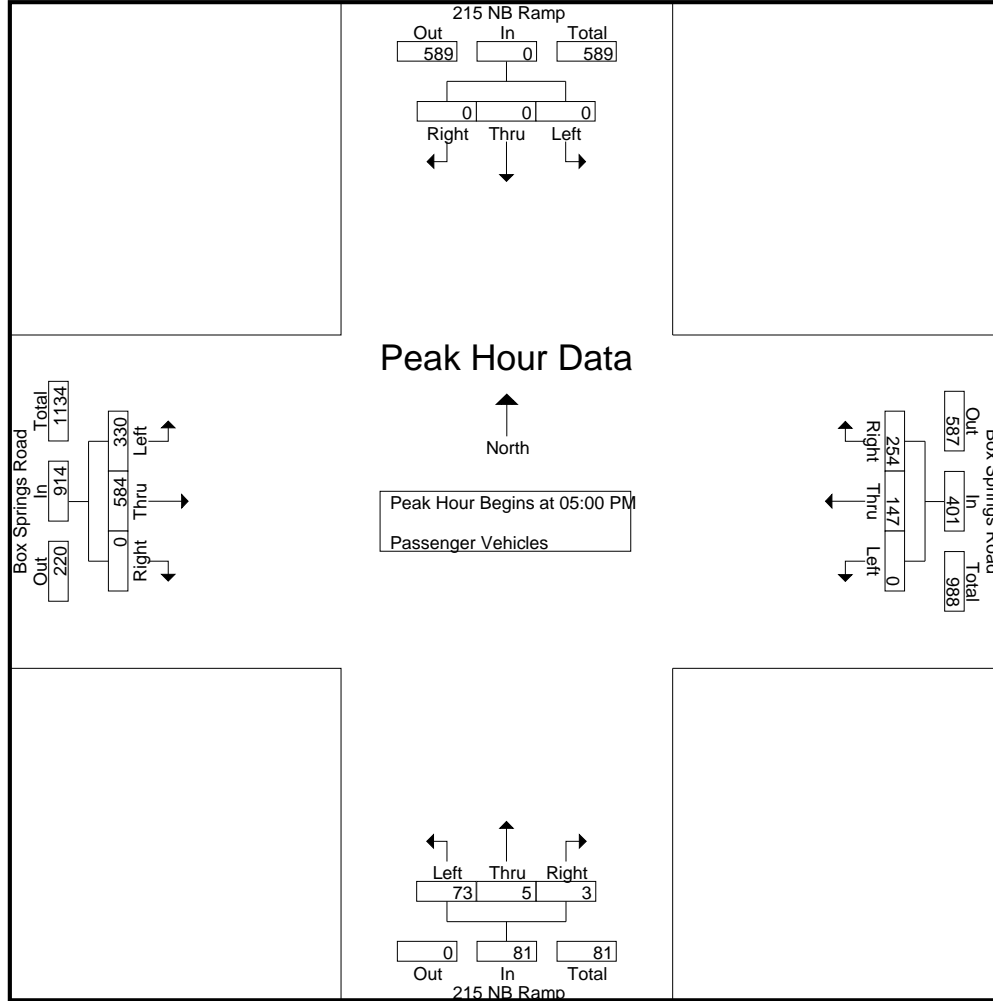

Peak Hour Analysis From 05:00 PM to 05:45 PM - Peak 1 of 1
 Peak Hour for Each Approach Begins at:

	05:00 PM				05:00 PM				05:00 PM				05:00 PM			
+0 mins.	0	0	0	0	0	45	65	110	19	0	0	19	131	98	0	229
+15 mins.	0	0	0	0	0	29	60	89	17	2	1	20	88	158	0	246
+30 mins.	0	0	0	0	0	42	64	106	21	1	2	24	62	164	0	226
+45 mins.	0	0	0	0	0	31	65	96	16	2	0	18	49	164	0	213
Total Volume	0	0	0	0	0	147	254	401	73	5	3	81	330	584	0	914
% App. Total	0	0	0	0	0	36.7	63.3		90.1	6.2	3.7		36.1	63.9	0	
PHF	.000	.000	.000	.000	.000	.817	.977	.911	.869	.625	.375	.844	.630	.890	.000	.929

Counts Unlimited Inc
PO Box 1178
Corona, CA 92878
(951) 268-6268

City of Riverside
N/S: I-215 NB Ramps
E/W: Box Springs Road
Weather: Clear

File Name : RIV215NBRPM
Site Code : 06715392
Start Date : 7/7/2015
Page No : 1

Groups Printed- Large 2 Axle Vehicles

Start Time	215 NB Ramp Southbound				Box Springs Road Westbound				215 NB Ramp Northbound				Box Springs Road Eastbound				Int. Total
	Left	Thru	Right	App. Total	Left	Thru	Right	App. Total	Left	Thru	Right	App. Total	Left	Thru	Right	App. Total	
04:00 PM	0	0	0	0	0	0	1	1	0	0	0	0	4	2	0	6	7
04:15 PM	0	0	0	0	0	2	1	3	2	0	0	2	3	1	0	4	9
04:30 PM	0	0	0	0	0	1	0	1	1	0	0	1	1	2	0	3	5
04:45 PM	0	0	0	0	0	0	1	1	2	0	0	2	2	1	0	3	6
Total	0	0	0	0	0	3	3	6	5	0	0	5	10	6	0	16	27
05:00 PM	0	0	0	0	0	1	2	3	0	0	0	0	2	5	0	7	10
05:15 PM	0	0	0	0	0	2	1	3	1	0	0	1	4	3	0	7	11
05:30 PM	0	0	0	0	0	0	0	0	1	0	0	1	1	0	0	1	2
05:45 PM	0	0	0	0	0	2	0	2	0	0	0	0	2	2	0	4	6
Total	0	0	0	0	0	5	3	8	2	0	0	2	9	10	0	19	29
Grand Total	0	0	0	0	0	8	6	14	7	0	0	7	19	16	0	35	56
Apprch %	0	0	0		0	57.1	42.9		100	0	0		54.3	45.7	0		
Total %	0	0	0		0	14.3	10.7	25	12.5	0	0	12.5	33.9	28.6	0	62.5	

Start Time	215 NB Ramp Southbound				Box Springs Road Westbound				215 NB Ramp Northbound				Box Springs Road Eastbound				Int. Total
	Left	Thru	Right	App. Total	Left	Thru	Right	App. Total	Left	Thru	Right	App. Total	Left	Thru	Right	App. Total	
Peak Hour Analysis From 05:00 PM to 05:45 PM - Peak 1 of 1																	
Peak Hour for Entire Intersection Begins at 05:00 PM																	
05:00 PM	0	0	0	0	0	1	2	3	0	0	0	0	2	5	0	7	10
05:15 PM	0	0	0	0	0	2	1	3	1	0	0	1	4	3	0	7	11
05:30 PM	0	0	0	0	0	0	0	0	1	0	0	1	1	0	0	1	2
05:45 PM	0	0	0	0	0	2	0	2	0	0	0	0	2	2	0	4	6
Total Volume	0	0	0	0	0	5	3	8	2	0	0	2	9	10	0	19	29
% App. Total	0	0	0		0	62.5	37.5		100	0	0		47.4	52.6	0		
PHF	.000	.000	.000	.000	.000	.625	.375	.667	.500	.000	.000	.500	.563	.500	.000	.679	.659

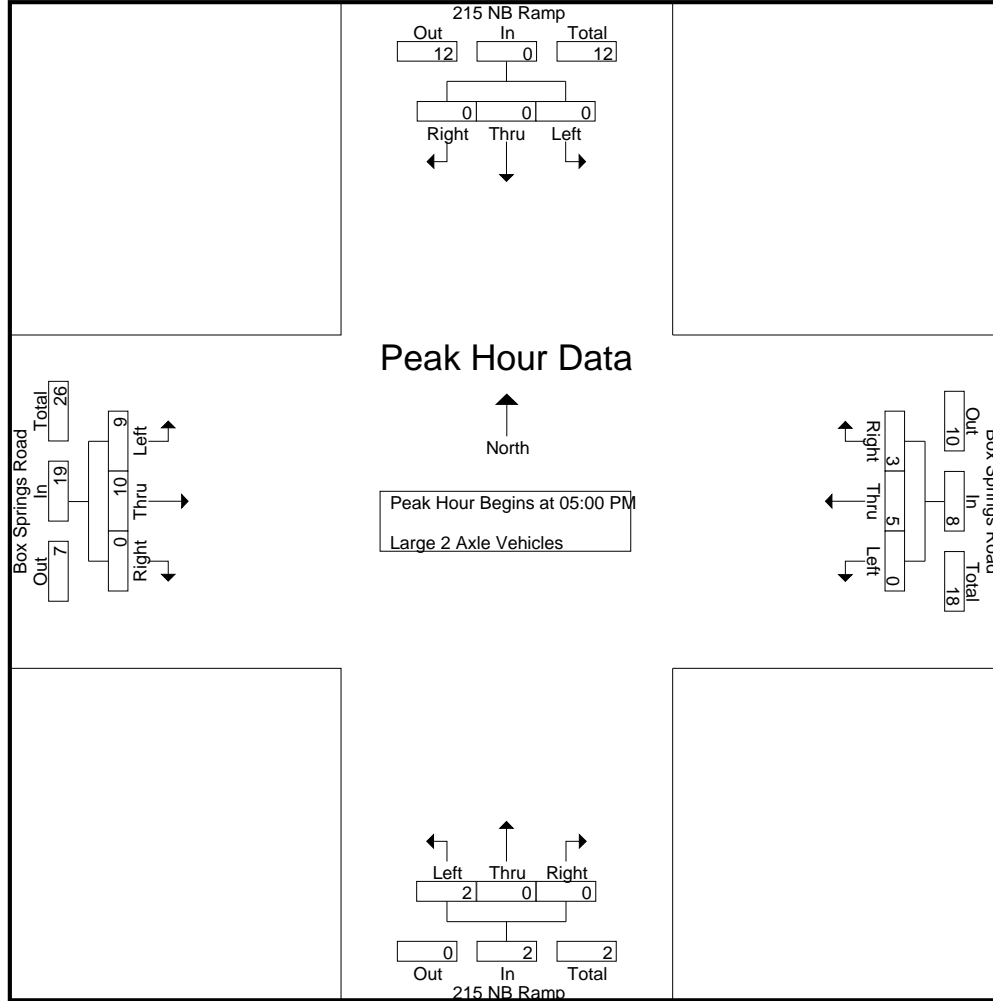

Peak Hour Analysis From 05:00 PM to 05:45 PM - Peak 1 of 1
 Peak Hour for Each Approach Begins at:

	05:00 PM				05:00 PM				05:00 PM				05:00 PM			
+0 mins.	0	0	0	0	0	1	2	3	0	0	0	0	2	5	0	7
+15 mins.	0	0	0	0	0	2	1	3	1	0	0	1	4	3	0	7
+30 mins.	0	0	0	0	0	0	0	0	1	0	0	1	1	0	0	1
+45 mins.	0	0	0	0	0	2	0	2	0	0	0	0	2	2	0	4
Total Volume	0	0	0	0	0	5	3	8	2	0	0	2	9	10	0	19
% App. Total	0	0	0	0	0	62.5	37.5		100	0	0		47.4	52.6	0	
PHF	.000	.000	.000	.000	.000	.625	.375	.667	.500	.000	.000	.500	.563	.500	.000	.679

Counts Unlimited Inc
 PO Box 1178
 Corona, CA 92878
 (951) 268-6268

City of Riverside
 N/S: I-215 NB Ramps
 E/W: Box Springs Road
 Weather: Clear

File Name : RIV215NBRPM
 Site Code : 06715392
 Start Date : 7/7/2015
 Page No : 1

Groups Printed- 3 Axle Vehicles

Start Time	215 NB Ramp Southbound				Box Springs Road Westbound				215 NB Ramp Northbound				Box Springs Road Eastbound				Int. Total
	Left	Thru	Right	App. Total	Left	Thru	Right	App. Total	Left	Thru	Right	App. Total	Left	Thru	Right	App. Total	
04:00 PM	0	0	0	0	0	0	0	0	0	0	0	0	1	0	0	1	1
04:15 PM	0	0	0	0	0	0	0	0	0	0	0	0	2	0	0	2	2
04:30 PM	0	0	0	0	0	0	0	0	0	0	0	0	0	0	0	0	0
04:45 PM	0	0	0	0	0	0	0	0	0	0	0	0	0	0	0	0	0
Total	0	0	0	0	0	0	0	0	0	0	0	0	3	0	0	3	3
05:00 PM	0	0	0	0	0	0	0	0	0	0	0	0	1	0	0	1	1
05:15 PM	0	0	0	0	0	0	0	0	0	0	0	0	1	0	0	1	1
05:30 PM	0	0	0	0	0	0	0	0	0	0	0	0	1	0	0	1	1
05:45 PM	0	0	0	0	0	0	0	0	0	0	0	0	1	0	0	1	1
Total	0	0	0	0	0	0	0	0	0	0	0	0	4	0	0	4	4
Grand Total	0	0	0	0	0	0	0	0	0	0	0	0	7	0	0	7	7
Apprch %	0	0	0		0	0	0		0	0	0		100	0	0		
Total %	0	0	0		0	0	0		0	0	0		100	0	0	100	

Start Time	215 NB Ramp Southbound				Box Springs Road Westbound				215 NB Ramp Northbound				Box Springs Road Eastbound				Int. Total
	Left	Thru	Right	App. Total	Left	Thru	Right	App. Total	Left	Thru	Right	App. Total	Left	Thru	Right	App. Total	
Peak Hour Analysis From 05:00 PM to 05:45 PM - Peak 1 of 1																	
Peak Hour for Entire Intersection Begins at 05:00 PM																	
05:00 PM	0	0	0	0	0	0	0	0	0	0	0	0	1	0	0	1	1
05:15 PM	0	0	0	0	0	0	0	0	0	0	0	0	1	0	0	1	1
05:30 PM	0	0	0	0	0	0	0	0	0	0	0	0	1	0	0	1	1
05:45 PM	0	0	0	0	0	0	0	0	0	0	0	0	1	0	0	1	1
Total Volume	0	0	0	0	0	0	0	0	0	0	0	0	4	0	0	4	4
% App. Total	0	0	0		0	0	0		0	0	0		100	0	0		
PHF	.000	.000	.000	.000	.000	.000	.000	.000	.000	.000	.000	.000	1.00	.000	.000	1.00	1.00

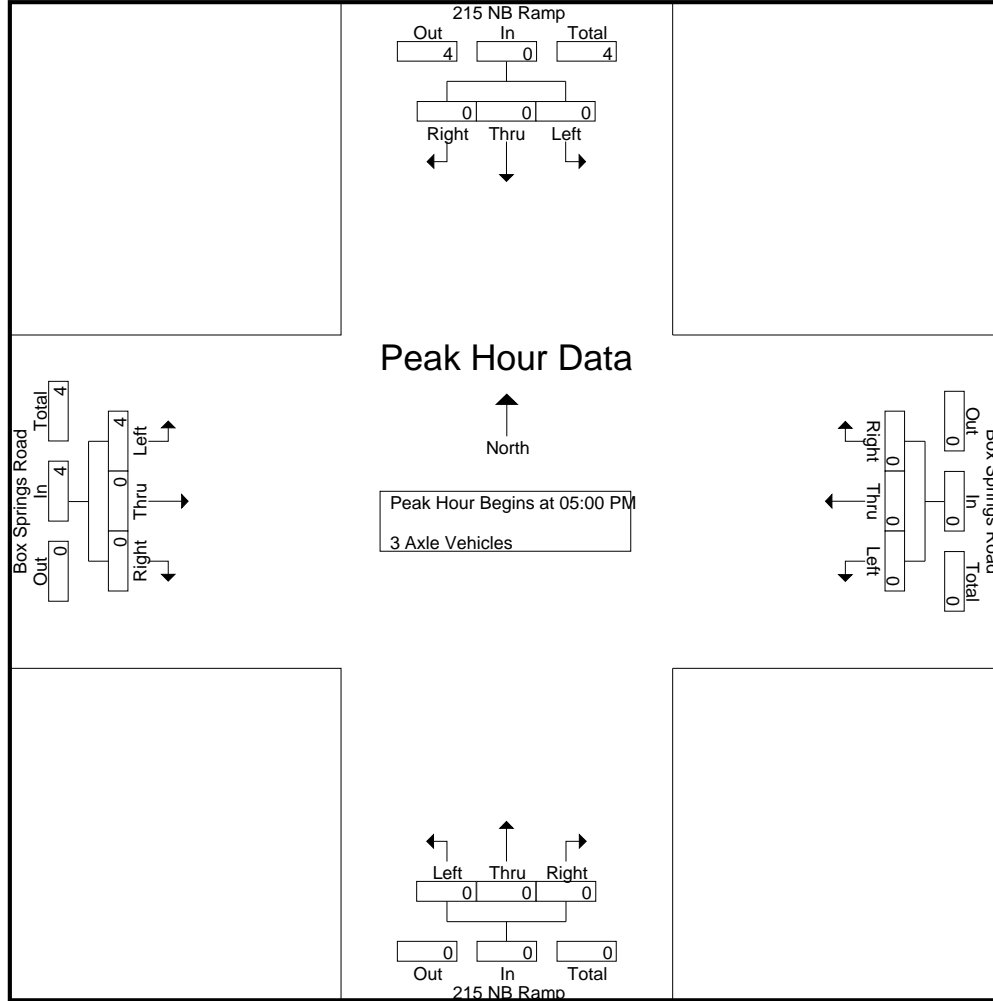

Peak Hour Analysis From 05:00 PM to 05:45 PM - Peak 1 of 1
 Peak Hour for Each Approach Begins at:

	05:00 PM				05:00 PM				05:00 PM				05:00 PM			
+0 mins.	0	0	0	0	0	0	0	0	0	0	0	0	1	0	0	1
+15 mins.	0	0	0	0	0	0	0	0	0	0	0	0	1	0	0	1
+30 mins.	0	0	0	0	0	0	0	0	0	0	0	0	1	0	0	1
+45 mins.	0	0	0	0	0	0	0	0	0	0	0	0	1	0	0	1
Total Volume	0	0	0	0	0	0	0	0	0	0	0	0	4	0	0	4
% App. Total	0	0	0	0	0	0	0	0	0	0	0	0	100	0	0	100
PHF	.000	.000	.000	.000	.000	.000	.000	.000	.000	.000	.000	.000	1.000	.000	.000	1.000

Counts Unlimited Inc
 PO Box 1178
 Corona, CA 92878
 (951) 268-6268

City of Riverside
 N/S: I-215 NB Ramps
 E/W: Box Springs Road
 Weather: Clear

File Name : RIV215NBRPM
 Site Code : 06715392
 Start Date : 7/7/2015
 Page No : 1

Groups Printed- 4+ Axle Trucks

Start Time	215 NB Ramp Southbound				Box Springs Road Westbound				215 NB Ramp Northbound				Box Springs Road Eastbound				Int. Total
	Left	Thru	Right	App. Total	Left	Thru	Right	App. Total	Left	Thru	Right	App. Total	Left	Thru	Right	App. Total	
04:00 PM	0	0	0	0	0	0	0	0	0	0	0	0	6	0	0	6	6
04:15 PM	0	0	0	0	0	0	0	0	0	0	0	0	5	0	0	5	5
04:30 PM	0	0	0	0	0	0	0	0	0	0	0	0	3	0	0	3	3
04:45 PM	0	0	0	0	0	0	0	0	0	0	0	0	5	0	0	5	5
Total	0	0	0	0	0	0	0	0	0	0	0	0	19	0	0	19	19
05:00 PM	0	0	0	0	0	0	0	0	0	0	0	0	5	0	0	5	5
05:15 PM	0	0	0	0	0	0	0	0	0	0	0	0	4	0	0	4	4
05:30 PM	0	0	0	0	0	0	0	0	0	0	0	0	4	0	0	4	4
05:45 PM	0	0	0	0	0	0	0	0	0	0	0	0	1	0	0	1	1
Total	0	0	0	0	0	0	0	0	0	0	0	0	14	0	0	14	14
Grand Total	0	0	0	0	0	0	0	0	0	0	0	0	33	0	0	33	33
Apprch %	0	0	0		0	0	0		0	0	0		100	0	0		
Total %	0	0	0		0	0	0		0	0	0		100	0	0		100

Start Time	215 NB Ramp Southbound				Box Springs Road Westbound				215 NB Ramp Northbound				Box Springs Road Eastbound				Int. Total
	Left	Thru	Right	App. Total	Left	Thru	Right	App. Total	Left	Thru	Right	App. Total	Left	Thru	Right	App. Total	
Peak Hour Analysis From 05:00 PM to 05:45 PM - Peak 1 of 1																	
Peak Hour for Entire Intersection Begins at 05:00 PM																	
05:00 PM	0	0	0	0	0	0	0	0	0	0	0	0	5	0	0	5	5
05:15 PM	0	0	0	0	0	0	0	0	0	0	0	0	4	0	0	4	4
05:30 PM	0	0	0	0	0	0	0	0	0	0	0	0	4	0	0	4	4
05:45 PM	0	0	0	0	0	0	0	0	0	0	0	0	1	0	0	1	1
Total Volume	0	0	0	0	0	0	0	0	0	0	0	0	14	0	0	14	14
% App. Total	0	0	0		0	0	0		0	0	0		100	0	0		
PHF	.000	.000	.000	.000	.000	.000	.000	.000	.000	.000	.000	.000	.700	.000	.000	.700	.700

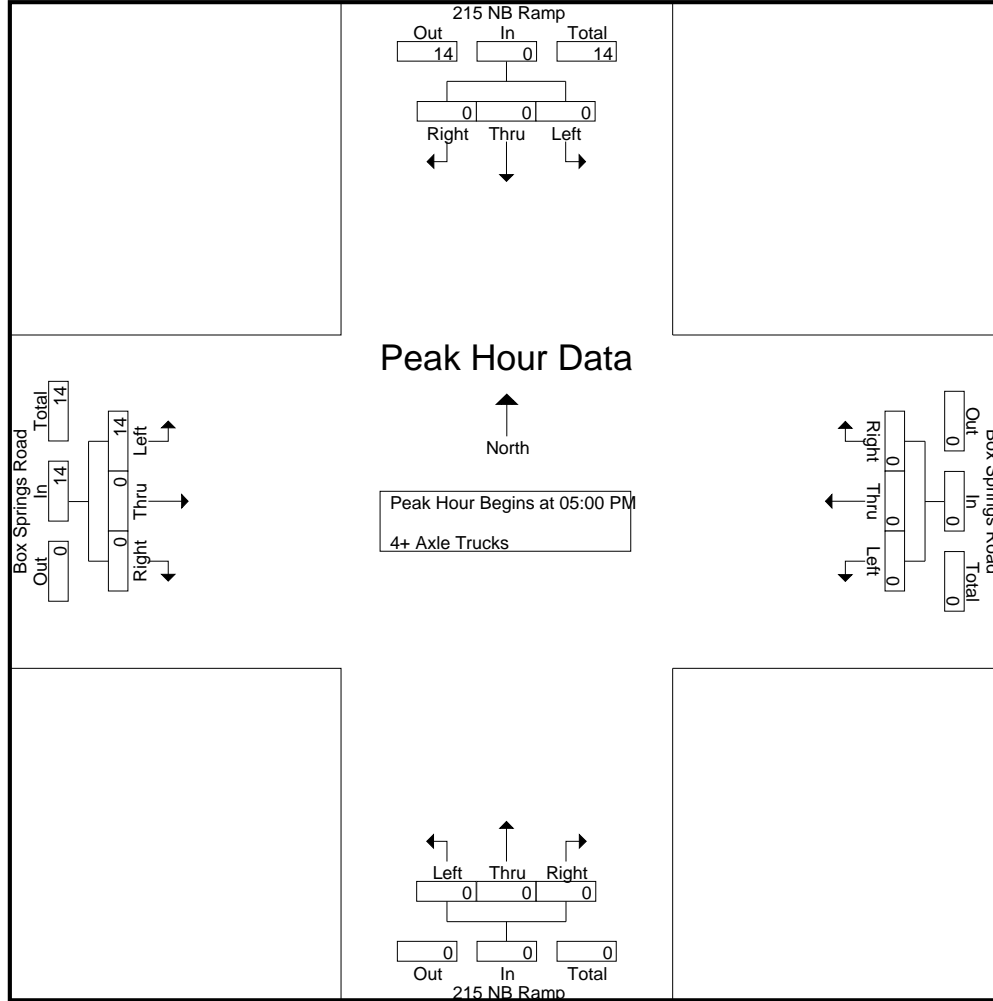

Peak Hour Analysis From 05:00 PM to 05:45 PM - Peak 1 of 1
 Peak Hour for Each Approach Begins at:

	05:00 PM				05:00 PM				05:00 PM				05:00 PM			
+0 mins.	0	0	0	0	0	0	0	0	0	0	0	0	5	0	0	5
+15 mins.	0	0	0	0	0	0	0	0	0	0	0	0	4	0	0	4
+30 mins.	0	0	0	0	0	0	0	0	0	0	0	0	4	0	0	4
+45 mins.	0	0	0	0	0	0	0	0	0	0	0	0	1	0	0	1
Total Volume	0	0	0	0	0	0	0	0	0	0	0	0	14	0	0	14
% App. Total	0	0	0	0	0	0	0	0	0	0	0	0	100	0	0	100
PHF	.000	.000	.000	.000	.000	.000	.000	.000	.000	.000	.000	.000	.700	.000	.000	.700

City of Riverside
 N/S: Sycamore Canyon Blvd
 E/W: Box Springs Road
 Weather: Clear

File Name : RIVSCBRAM
 Site Code : 06715392
 Start Date : 7/7/2015
 Page No : 1

Groups Printed- Passenger Vehicles - Large 2 Axle Vehicles - 3 Axle Vehicles - 4+ Axle Trucks

Start Time	Sycamore Canyon Blvd Southbound				Box Springs Road Westbound				Sycamore Canyon Blvd Northbound				Box Springs Road Eastbound				Int. Total
	Left	Thru	Right	App. Total	Left	Thru	Right	App. Total	Left	Thru	Right	App. Total	Left	Thru	Right	App. Total	
07:00 AM	14	18	1	33	24	14	73	111	18	212	87	317	6	22	17	45	506
07:15 AM	3	33	2	38	24	7	71	102	22	253	99	374	7	27	26	60	574
07:30 AM	8	30	4	42	22	16	85	123	23	233	123	379	14	21	23	58	602
07:45 AM	13	27	6	46	33	19	88	140	37	217	116	370	5	13	27	45	601
Total	38	108	13	159	103	56	317	476	100	915	425	1440	32	83	93	208	2283
08:00 AM	8	21	2	31	27	9	65	101	33	178	76	287	6	16	21	43	462
08:15 AM	10	30	1	41	27	10	72	109	27	163	94	284	13	24	21	58	492
08:30 AM	17	28	4	49	18	6	38	62	20	136	109	265	10	22	21	53	429
08:45 AM	18	25	4	47	32	5	30	67	27	77	83	187	3	31	33	67	368
Total	53	104	11	168	104	30	205	339	107	554	362	1023	32	93	96	221	1751
Grand Total	91	212	24	327	207	86	522	815	207	1469	787	2463	64	176	189	429	4034
Apprch %	27.8	64.8	7.3		25.4	10.6	64		8.4	59.6	32		14.9	41	44.1		
Total %	2.3	5.3	0.6	8.1	5.1	2.1	12.9	20.2	5.1	36.4	19.5	61.1	1.6	4.4	4.7	10.6	
Passenger Vehicles	89	188	23	300	196	84	511	791	192	1412	677	2281	60	169	180	409	3781
% Passenger Vehicles	97.8	88.7	95.8	91.7	94.7	97.7	97.9	97.1	92.8	96.1	86	92.6	93.8	96	95.2	95.3	93.7
Large 2 Axle Vehicles	2	20	0	22	11	2	8	21	15	37	32	84	4	7	8	19	146
% Large 2 Axle Vehicles	2.2	9.4	0	6.7	5.3	2.3	1.5	2.6	7.2	2.5	4.1	3.4	6.2	4	4.2	4.4	3.6
3 Axle Vehicles	0	3	1	4	0	0	0	0	0	5	4	9	0	0	1	1	14
% 3 Axle Vehicles	0	1.4	4.2	1.2	0	0	0	0	0	0.3	0.5	0.4	0	0	0.5	0.2	0.3
4+ Axle Trucks	0	1	0	1	0	0	3	3	0	15	74	89	0	0	0	0	93
% 4+ Axle Trucks	0	0.5	0	0.3	0	0	0.6	0.4	0	1	9.4	3.6	0	0	0	0	2.3

Start Time	Sycamore Canyon Blvd Southbound				Box Springs Road Westbound				Sycamore Canyon Blvd Northbound				Box Springs Road Eastbound				Int. Total
	Left	Thru	Right	App. Total	Left	Thru	Right	App. Total	Left	Thru	Right	App. Total	Left	Thru	Right	App. Total	
07:00 AM	14	18	1	33	24	14	73	111	18	212	87	317	6	22	17	45	506
07:15 AM	3	33	2	38	24	7	71	102	22	253	99	374	7	27	26	60	574
07:30 AM	8	30	4	42	22	16	85	123	23	233	123	379	14	21	23	58	602
07:45 AM	13	27	6	46	33	19	88	140	37	217	116	370	5	13	27	45	601
Total Volume	38	108	13	159	103	56	317	476	100	915	425	1440	32	83	93	208	2283
% App. Total	23.9	67.9	8.2		21.6	11.8	66.6		6.9	63.5	29.5		15.4	39.9	44.7		
PHF	.679	.818	.542	.864	.780	.737	.901	.850	.676	.904	.864	.950	.571	.769	.861	.867	.948

Peak Hour Analysis From 07:00 AM to 08:45 AM - Peak 1 of 1
 Peak Hour for Entire Intersection Begins at 07:00 AM

City of Riverside
 N/S: Sycamore Canyon Blvd
 E/W: Box Springs Road
 Weather: Clear

File Name : RIVSCBRAM
 Site Code : 06715392
 Start Date : 7/7/2015
 Page No : 2

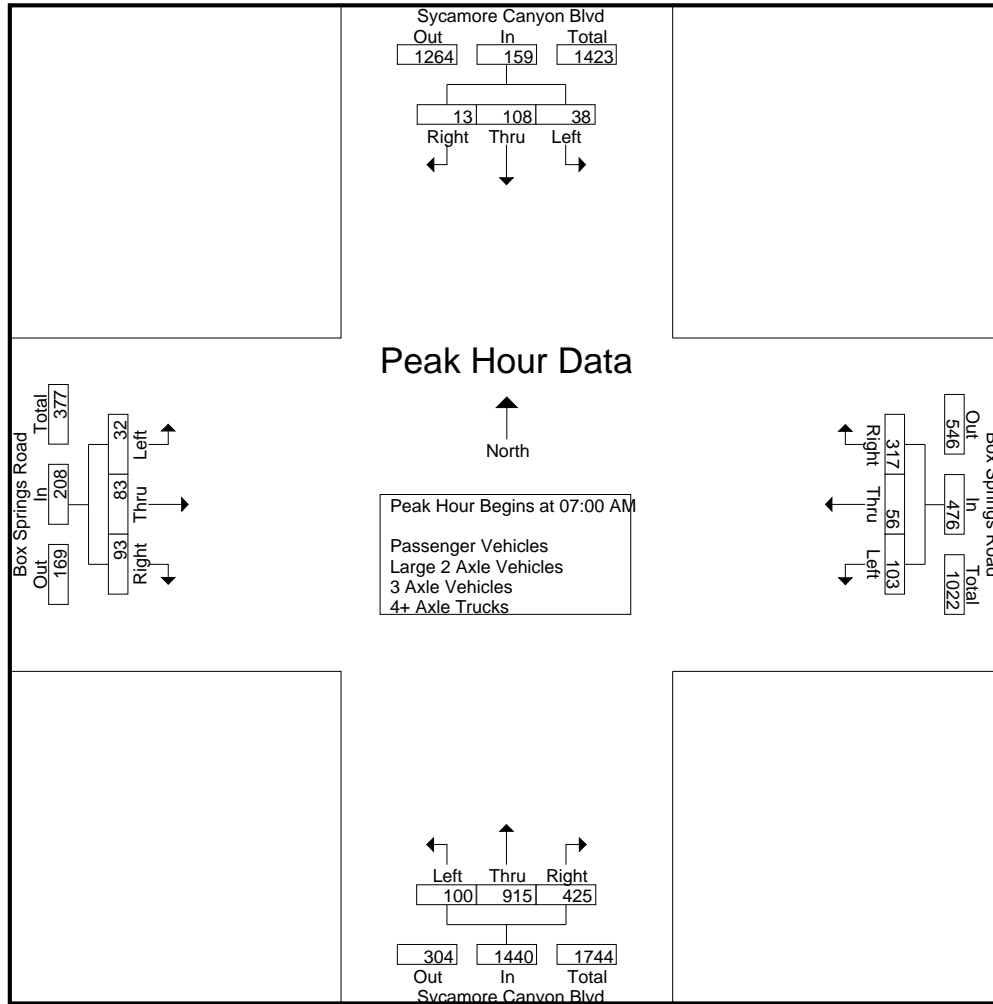

Peak Hour Analysis From 07:00 AM to 08:45 AM - Peak 1 of 1
 Peak Hour for Each Approach Begins at:

	08:00 AM				07:00 AM				07:00 AM				08:00 AM			
+0 mins.	8	21	2	31	24	14	73	111	18	212	87	317	6	16	21	43
+15 mins.	10	30	1	41	24	7	71	102	22	253	99	374	13	24	21	58
+30 mins.	17	28	4	49	22	16	85	123	23	233	123	379	10	22	21	53
+45 mins.	18	25	4	47	33	19	88	140	37	217	116	370	3	31	33	67
Total Volume	53	104	11	168	103	56	317	476	100	915	425	1440	32	93	96	221
% App. Total	31.5	61.9	6.5		21.6	11.8	66.6		6.9	63.5	29.5		14.5	42.1	43.4	
PHF	.736	.867	.688	.857	.780	.737	.901	.850	.676	.904	.864	.950	.615	.750	.727	.825

City of Riverside
 N/S: Sycamore Canyon Blvd
 E/W: Box Springs Road
 Weather: Clear

File Name : RIVSCBRAM
 Site Code : 06715392
 Start Date : 7/7/2015
 Page No : 1

Groups Printed- Passenger Vehicles

Start Time	Sycamore Canyon Blvd Southbound				Box Springs Road Westbound				Sycamore Canyon Blvd Northbound				Box Springs Road Eastbound				Int. Total
	Left	Thru	Right	App. Total	Left	Thru	Right	App. Total	Left	Thru	Right	App. Total	Left	Thru	Right	App. Total	
07:00 AM	14	13	1	28	24	14	73	111	17	208	71	296	6	21	16	43	478
07:15 AM	3	32	1	36	21	7	70	98	21	245	87	353	6	27	23	56	543
07:30 AM	8	26	4	38	22	16	80	118	21	221	109	351	14	20	22	56	563
07:45 AM	13	27	6	46	31	19	86	136	37	210	103	350	4	13	26	43	575
Total	38	98	12	148	98	56	309	463	96	884	370	1350	30	81	87	198	2159
08:00 AM	7	14	2	23	25	7	64	96	30	165	59	254	6	15	20	41	414
08:15 AM	9	27	1	37	26	10	72	108	24	156	74	254	12	22	20	54	453
08:30 AM	17	24	4	45	16	6	37	59	17	132	95	244	10	20	21	51	399
08:45 AM	18	25	4	47	31	5	29	65	25	75	79	179	2	31	32	65	356
Total	51	90	11	152	98	28	202	328	96	528	307	931	30	88	93	211	1622
Grand Total	89	188	23	300	196	84	511	791	192	1412	677	2281	60	169	180	409	3781
Apprch %	29.7	62.7	7.7		24.8	10.6	64.6		8.4	61.9	29.7		14.7	41.3	44		
Total %	2.4	5	0.6	7.9	5.2	2.2	13.5	20.9	5.1	37.3	17.9	60.3	1.6	4.5	4.8	10.8	

Start Time	Sycamore Canyon Blvd Southbound				Box Springs Road Westbound				Sycamore Canyon Blvd Northbound				Box Springs Road Eastbound				Int. Total
	Left	Thru	Right	App. Total	Left	Thru	Right	App. Total	Left	Thru	Right	App. Total	Left	Thru	Right	App. Total	
07:00 AM	14	13	1	28	24	14	73	111	17	208	71	296	6	21	16	43	478
07:15 AM	3	32	1	36	21	7	70	98	21	245	87	353	6	27	23	56	543
07:30 AM	8	26	4	38	22	16	80	118	21	221	109	351	14	20	22	56	563
07:45 AM	13	27	6	46	31	19	86	136	37	210	103	350	4	13	26	43	575
Total	38	98	12	148	98	56	309	463	96	884	370	1350	30	81	87	198	2159
Total Volume % App. Total	25.7	66.2	8.1		21.2	12.1	66.7		7.1	65.5	27.4		15.2	40.9	43.9		
PHF	.679	.766	.500	.804	.790	.737	.898	.851	.649	.902	.849	.956	.536	.750	.837	.884	.939

Peak Hour Analysis From 07:00 AM to 07:45 AM - Peak 1 of 1

Peak Hour for Entire Intersection Begins at 07:00 AM

City of Riverside
 N/S: Sycamore Canyon Blvd
 E/W: Box Springs Road
 Weather: Clear

File Name : RIVSCBRAM
 Site Code : 06715392
 Start Date : 7/7/2015
 Page No : 2

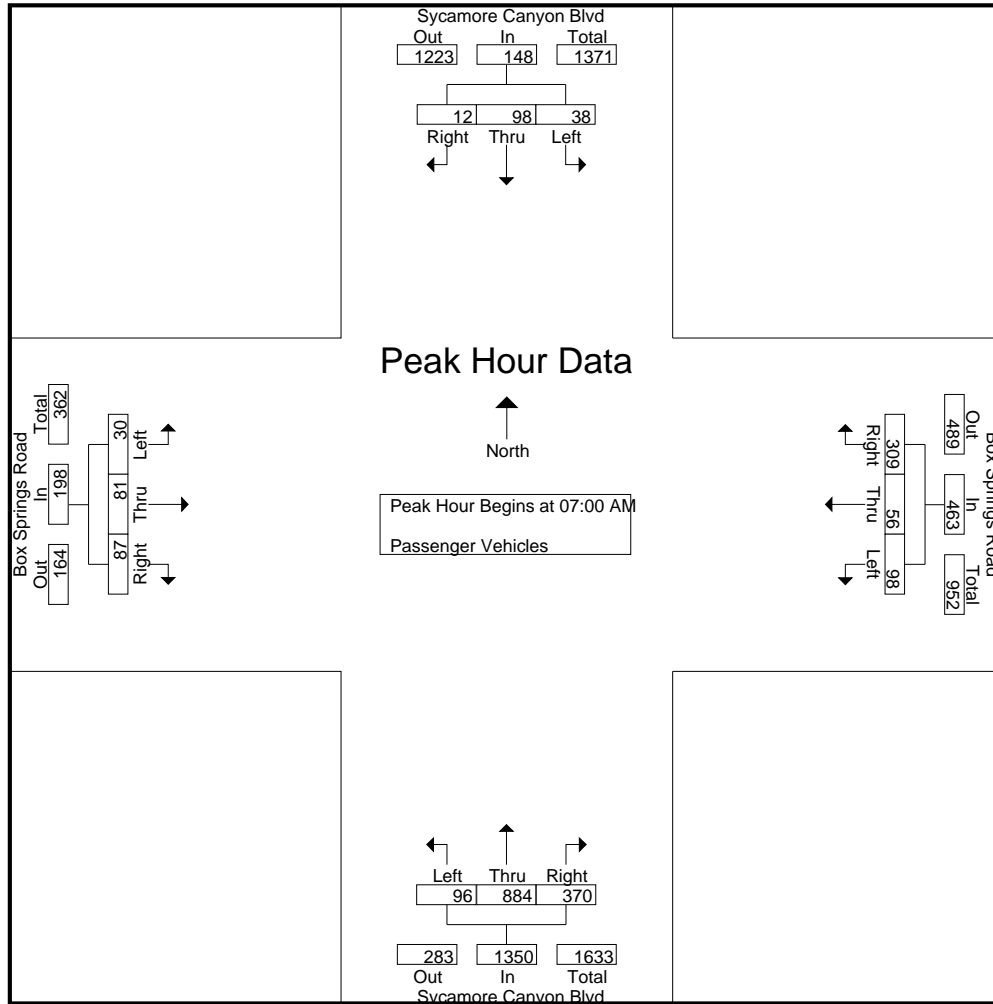

Peak Hour Analysis From 07:00 AM to 07:45 AM - Peak 1 of 1
 Peak Hour for Each Approach Begins at:

	07:00 AM				07:00 AM				07:00 AM				07:00 AM			
+0 mins.	14	13	1	28	24	14	73	111	17	208	71	296	6	21	16	43
+15 mins.	3	32	1	36	21	7	70	98	21	245	87	353	6	27	23	56
+30 mins.	8	26	4	38	22	16	80	118	21	221	109	351	14	20	22	56
+45 mins.	13	27	6	46	31	19	86	136	37	210	103	350	4	13	26	43
Total Volume	38	98	12	148	98	56	309	463	96	884	370	1350	30	81	87	198
% App. Total	25.7	66.2	8.1		21.2	12.1	66.7		7.1	65.5	27.4		15.2	40.9	43.9	
PHF	.679	.766	.500	.804	.790	.737	.898	.851	.649	.902	.849	.956	.536	.750	.837	.884

City of Riverside
 N/S: Sycamore Canyon Blvd
 E/W: Box Springs Road
 Weather: Clear

File Name : RIVSCBRAM
 Site Code : 06715392
 Start Date : 7/7/2015
 Page No : 1

Groups Printed- Large 2 Axle Vehicles

Start Time	Sycamore Canyon Blvd Southbound				Box Springs Road Westbound				Sycamore Canyon Blvd Northbound				Box Springs Road Eastbound				Int. Total
	Left	Thru	Right	App. Total	Left	Thru	Right	App. Total	Left	Thru	Right	App. Total	Left	Thru	Right	App. Total	
07:00 AM	0	2	0	2	0	0	0	0	1	4	4	9	0	1	1	2	13
07:15 AM	0	1	0	1	3	0	1	4	1	6	2	9	1	0	2	3	17
07:30 AM	0	4	0	4	0	0	2	2	2	5	5	12	0	1	1	2	20
07:45 AM	0	0	0	0	2	0	2	4	0	5	3	8	1	0	1	2	14
Total	0	7	0	7	5	0	5	10	4	20	14	38	2	2	5	9	64
08:00 AM	1	7	0	8	2	2	1	5	3	7	3	13	0	1	1	2	28
08:15 AM	1	2	0	3	1	0	0	1	3	6	7	16	1	2	1	4	24
08:30 AM	0	4	0	4	2	0	1	3	3	2	6	11	0	2	0	2	20
08:45 AM	0	0	0	0	1	0	1	2	2	2	2	6	1	0	1	2	10
Total	2	13	0	15	6	2	3	11	11	17	18	46	2	5	3	10	82
Grand Total	2	20	0	22	11	2	8	21	15	37	32	84	4	7	8	19	146
Apprch %	9.1	90.9	0		52.4	9.5	38.1		17.9	44	38.1		21.1	36.8	42.1		
Total %	1.4	13.7	0	15.1	7.5	1.4	5.5	14.4	10.3	25.3	21.9	57.5	2.7	4.8	5.5	13	

Start Time	Sycamore Canyon Blvd Southbound				Box Springs Road Westbound				Sycamore Canyon Blvd Northbound				Box Springs Road Eastbound				Int. Total
	Left	Thru	Right	App. Total	Left	Thru	Right	App. Total	Left	Thru	Right	App. Total	Left	Thru	Right	App. Total	
07:00 AM	0	2	0	2	0	0	0	0	1	4	4	9	0	1	1	2	13
07:15 AM	0	1	0	1	3	0	1	4	1	6	2	9	1	0	2	3	17
07:30 AM	0	4	0	4	0	0	2	2	2	5	5	12	0	1	1	2	20
07:45 AM	0	0	0	0	2	0	2	4	0	5	3	8	1	0	1	2	14
Total	0	7	0	7	5	0	5	10	4	20	14	38	2	2	5	9	64
Total Volume	0	7	0	7	5	0	5	10	4	20	14	38	2	2	5	9	64
% App. Total	0	100	0		50	0	50		10.5	52.6	36.8		22.2	22.2	55.6		
PHF	.000	.438	.000	.438	.417	.000	.625	.625	.500	.833	.700	.792	.500	.500	.625	.750	.800

Peak Hour Analysis From 07:00 AM to 07:45 AM - Peak 1 of 1

Peak Hour for Entire Intersection Begins at 07:00 AM

City of Riverside
 N/S: Sycamore Canyon Blvd
 E/W: Box Springs Road
 Weather: Clear

File Name : RIVSCBRAM
 Site Code : 06715392
 Start Date : 7/7/2015
 Page No : 2

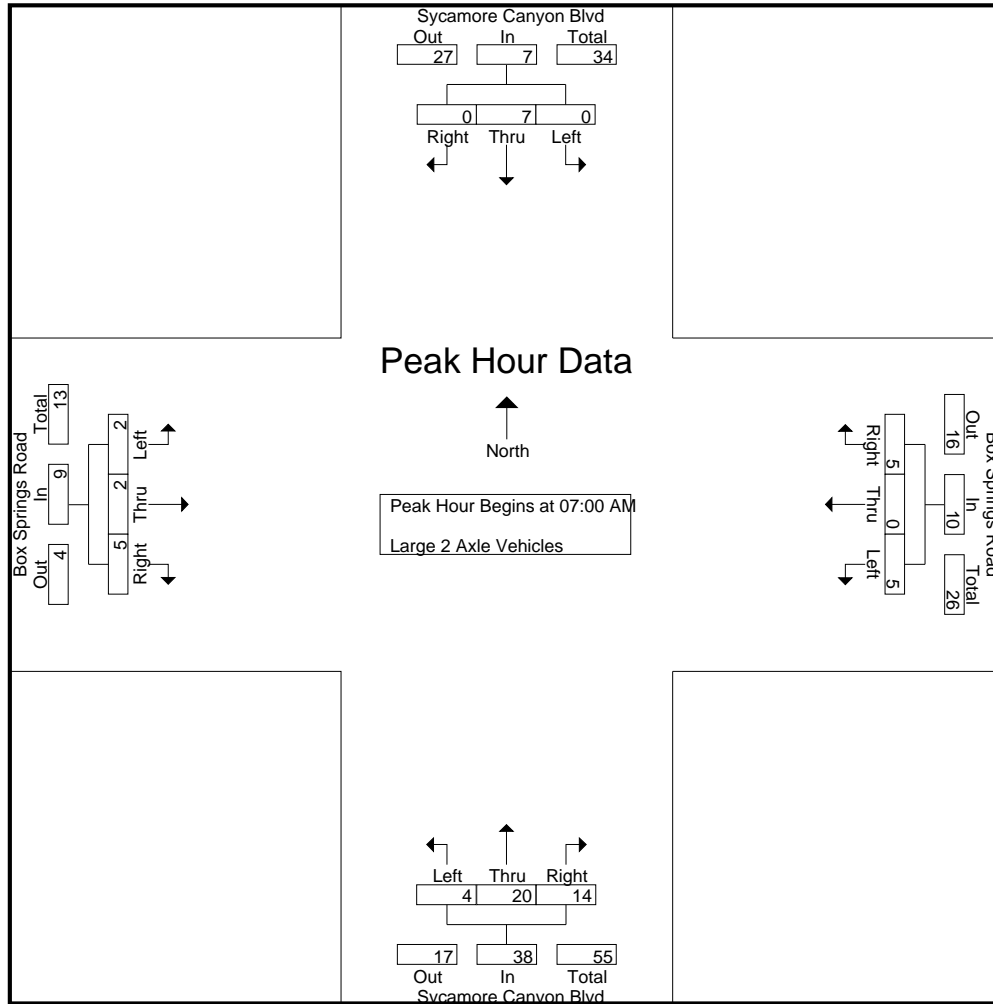

Peak Hour Analysis From 07:00 AM to 07:45 AM - Peak 1 of 1
 Peak Hour for Each Approach Begins at:

	07:00 AM				07:00 AM				07:00 AM				07:00 AM			
+0 mins.	0	2	0	2	0	0	0	0	1	4	4	9	0	1	1	2
+15 mins.	0	1	0	1	3	0	1	4	1	6	2	9	1	0	2	3
+30 mins.	0	4	0	4	0	0	2	2	2	5	5	12	0	1	1	2
+45 mins.	0	0	0	0	2	0	2	4	0	5	3	8	1	0	1	2
Total Volume	0	7	0	7	5	0	5	10	4	20	14	38	2	2	5	9
% App. Total	0	100	0		50	0	50		10.5	52.6	36.8		22.2	22.2	55.6	
PHF	.000	.438	.000	.438	.417	.000	.625	.625	.500	.833	.700	.792	.500	.500	.625	.750

City of Riverside
 N/S: Sycamore Canyon Blvd
 E/W: Box Springs Road
 Weather: Clear

File Name : RIVSCBRAM
 Site Code : 06715392
 Start Date : 7/7/2015
 Page No : 1

Groups Printed- 3 Axle Vehicles

Start Time	Sycamore Canyon Blvd Southbound				Box Springs Road Westbound				Sycamore Canyon Blvd Northbound				Box Springs Road Eastbound				Int. Total	
	Left	Thru	Right	App. Total	Left	Thru	Right	App. Total	Left	Thru	Right	App. Total	Left	Thru	Right	App. Total		
07:00 AM	0	2	0	2	0	0	0	0	0	0	0	0	0	0	0	0	0	2
07:15 AM	0	0	1	1	0	0	0	0	0	1	1	2	0	0	1	1	1	4
07:30 AM	0	0	0	0	0	0	0	0	0	0	0	0	0	0	0	0	0	0
07:45 AM	0	0	0	0	0	0	0	0	0	1	1	2	0	0	0	0	0	2
Total	0	2	1	3	0	0	0	0	0	2	2	4	0	0	1	1	1	8
08:00 AM	0	0	0	0	0	0	0	0	0	2	1	3	0	0	0	0	0	3
08:15 AM	0	1	0	1	0	0	0	0	0	0	0	0	0	0	0	0	0	1
08:30 AM	0	0	0	0	0	0	0	0	0	1	1	2	0	0	0	0	0	2
08:45 AM	0	0	0	0	0	0	0	0	0	0	0	0	0	0	0	0	0	0
Total	0	1	0	1	0	0	0	0	0	3	2	5	0	0	0	0	0	6
Grand Total	0	3	1	4	0	0	0	0	0	5	4	9	0	0	1	1	1	14
Apprch %	0	75	25		0	0	0		0	55.6	44.4		0	0	100			
Total %	0	21.4	7.1	28.6	0	0	0	0	0	35.7	28.6	64.3	0	0	7.1	7.1		

Start Time	Sycamore Canyon Blvd Southbound				Box Springs Road Westbound				Sycamore Canyon Blvd Northbound				Box Springs Road Eastbound				Int. Total	
	Left	Thru	Right	App. Total	Left	Thru	Right	App. Total	Left	Thru	Right	App. Total	Left	Thru	Right	App. Total		
07:00 AM	0	2	0	2	0	0	0	0	0	0	0	0	0	0	0	0	0	2
07:15 AM	0	0	1	1	0	0	0	0	0	1	1	2	0	0	1	1	1	4
07:30 AM	0	0	0	0	0	0	0	0	0	0	0	0	0	0	0	0	0	0
07:45 AM	0	0	0	0	0	0	0	0	0	1	1	2	0	0	0	0	0	2
Total Volume	0	2	1	3	0	0	0	0	0	2	2	4	0	0	1	1	1	8
% App. Total	0	66.7	33.3		0	0	0		0	50	50		0	0	100			
PHF	.000	.250	.250	.375	.000	.000	.000	.000	.000	.500	.500	.500	.000	.000	.250	.250	.500	.500

Peak Hour Analysis From 07:00 AM to 07:45 AM - Peak 1 of 1

Peak Hour for Entire Intersection Begins at 07:00 AM

City of Riverside
 N/S: Sycamore Canyon Blvd
 E/W: Box Springs Road
 Weather: Clear

File Name : RIVSCBRAM
 Site Code : 06715392
 Start Date : 7/7/2015
 Page No : 2

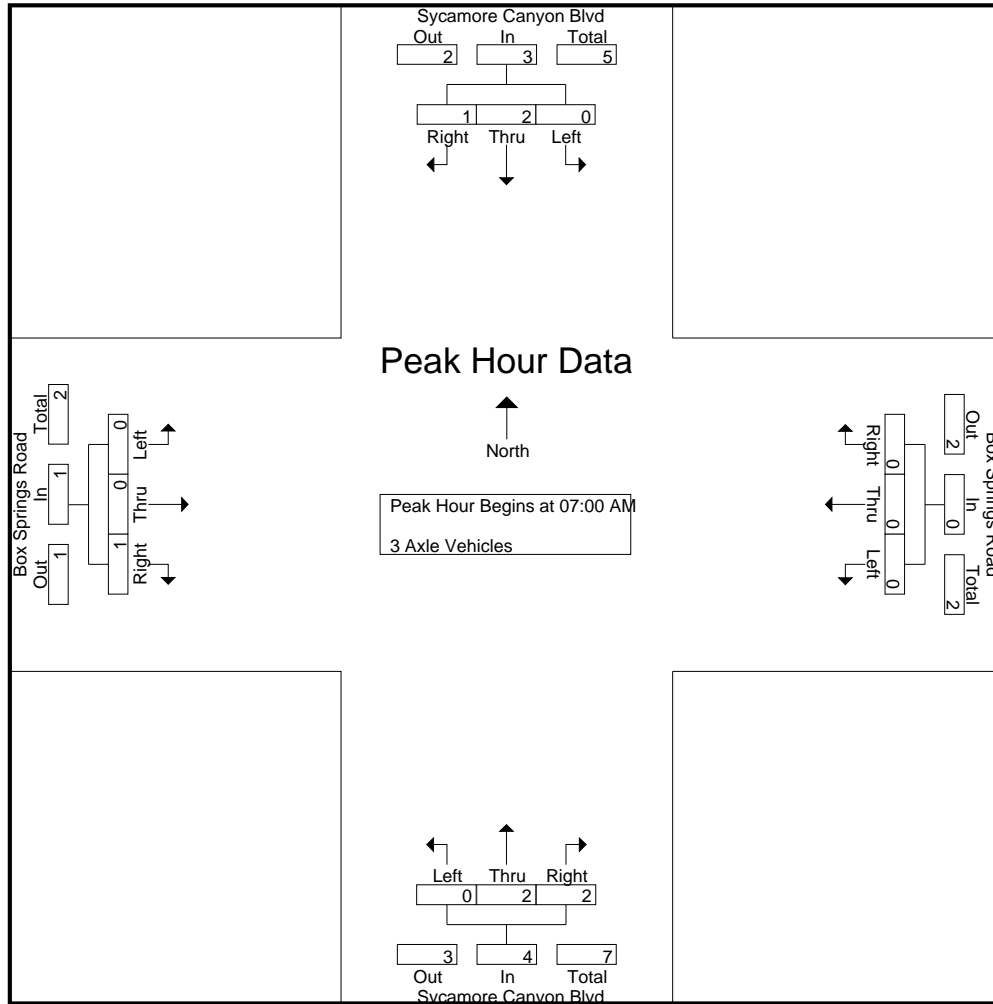

Peak Hour Analysis From 07:00 AM to 07:45 AM - Peak 1 of 1
 Peak Hour for Each Approach Begins at:

	07:00 AM				07:00 AM				07:00 AM				07:00 AM			
+0 mins.	0	2	0	2	0	0	0	0	0	0	0	0	0	0	0	0
+15 mins.	0	0	1	1	0	0	0	0	0	1	1	2	0	0	1	1
+30 mins.	0	0	0	0	0	0	0	0	0	0	0	0	0	0	0	0
+45 mins.	0	0	0	0	0	0	0	0	0	1	1	2	0	0	0	0
Total Volume	0	2	1	3	0	0	0	0	0	2	2	4	0	0	1	1
% App. Total	0	66.7	33.3		0	0	0		0	50	50		0	0	100	
PHF	.000	.250	.250	.375	.000	.000	.000	.000	.000	.500	.500	.500	.000	.000	.250	.250

City of Riverside
 N/S: Sycamore Canyon Blvd
 E/W: Box Springs Road
 Weather: Clear

File Name : RIVSCBRAM
 Site Code : 06715392
 Start Date : 7/7/2015
 Page No : 1

Groups Printed- 4+ Axle Trucks

Start Time	Sycamore Canyon Blvd Southbound				Box Springs Road Westbound				Sycamore Canyon Blvd Northbound				Box Springs Road Eastbound				Int. Total
	Left	Thru	Right	App. Total	Left	Thru	Right	App. Total	Left	Thru	Right	App. Total	Left	Thru	Right	App. Total	
07:00 AM	0	1	0	1	0	0	0	0	0	0	12	12	0	0	0	0	13
07:15 AM	0	0	0	0	0	0	0	0	0	1	9	10	0	0	0	0	10
07:30 AM	0	0	0	0	0	0	3	3	0	7	9	16	0	0	0	0	19
07:45 AM	0	0	0	0	0	0	0	0	0	1	9	10	0	0	0	0	10
Total	0	1	0	1	0	0	3	3	0	9	39	48	0	0	0	0	52
08:00 AM	0	0	0	0	0	0	0	0	0	4	13	17	0	0	0	0	17
08:15 AM	0	0	0	0	0	0	0	0	0	1	13	14	0	0	0	0	14
08:30 AM	0	0	0	0	0	0	0	0	0	1	7	8	0	0	0	0	8
08:45 AM	0	0	0	0	0	0	0	0	0	0	2	2	0	0	0	0	2
Total	0	0	0	0	0	0	0	0	0	6	35	41	0	0	0	0	41
Grand Total	0	1	0	1	0	0	3	3	0	15	74	89	0	0	0	0	93
Apprch %	0	100	0		0	0	100		0	16.9	83.1		0	0	0		
Total %	0	1.1	0	1.1	0	0	3.2	3.2	0	16.1	79.6	95.7	0	0	0	0	

Start Time	Sycamore Canyon Blvd Southbound				Box Springs Road Westbound				Sycamore Canyon Blvd Northbound				Box Springs Road Eastbound				Int. Total
	Left	Thru	Right	App. Total	Left	Thru	Right	App. Total	Left	Thru	Right	App. Total	Left	Thru	Right	App. Total	
07:00 AM	0	1	0	1	0	0	0	0	0	0	12	12	0	0	0	0	13
07:15 AM	0	0	0	0	0	0	0	0	0	1	9	10	0	0	0	0	10
07:30 AM	0	0	0	0	0	0	3	3	0	7	9	16	0	0	0	0	19
07:45 AM	0	0	0	0	0	0	0	0	0	1	9	10	0	0	0	0	10
Total	0	1	0	1	0	0	3	3	0	9	39	48	0	0	0	0	52
Total Volume	0	1	0	1	0	0	3	3	0	9	39	48	0	0	0	0	52
% App. Total	0	100	0		0	0	100		0	18.8	81.2		0	0	0		
PHF	.000	.250	.000	.250	.000	.000	.250	.250	.000	.321	.813	.750	.000	.000	.000	.000	.684

Peak Hour Analysis From 07:00 AM to 07:45 AM - Peak 1 of 1

Peak Hour for Entire Intersection Begins at 07:00 AM

City of Riverside
 N/S: Sycamore Canyon Blvd
 E/W: Box Springs Road
 Weather: Clear

File Name : RIVSCBRAM
 Site Code : 06715392
 Start Date : 7/7/2015
 Page No : 2

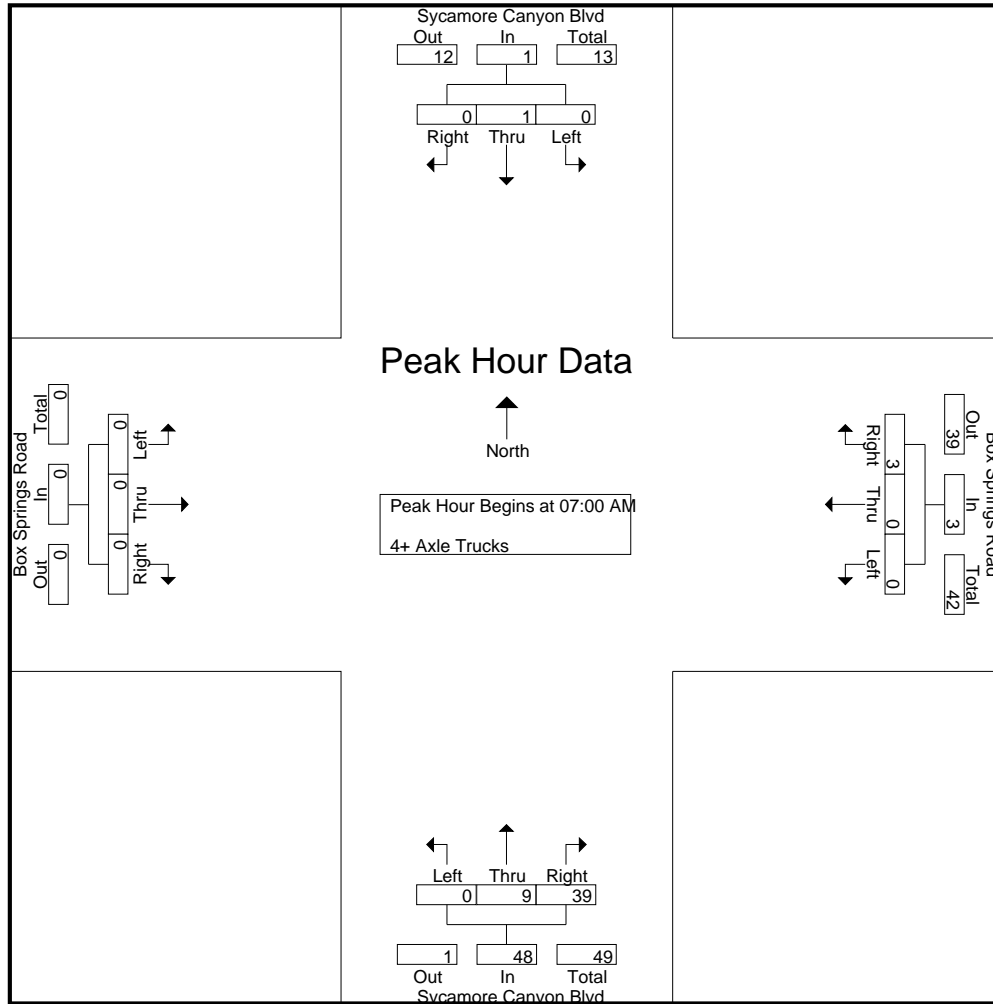

Peak Hour Analysis From 07:00 AM to 07:45 AM - Peak 1 of 1
 Peak Hour for Each Approach Begins at:

	07:00 AM				07:00 AM				07:00 AM				07:00 AM			
+0 mins.	0	1	0	1	0	0	0	0	0	0	12	12	0	0	0	0
+15 mins.	0	0	0	0	0	0	0	0	0	1	9	10	0	0	0	0
+30 mins.	0	0	0	0	0	0	3	3	0	7	9	16	0	0	0	0
+45 mins.	0	0	0	0	0	0	0	0	0	1	9	10	0	0	0	0
Total Volume	0	1	0	1	0	0	3	3	0	9	39	48	0	0	0	0
% App. Total	0	100	0		0	0	100		0	18.8	81.2		0	0	0	
PHF	.000	.250	.000	.250	.000	.000	.250	.250	.000	.321	.813	.750	.000	.000	.000	.000

City of Riverside
 N/S: Sycamore Canyon Blvd
 E/W: Box Springs Road
 Weather: Clear

File Name : RIVSCBRPM
 Site Code : 06715392
 Start Date : 7/7/2015
 Page No : 1

Groups Printed- Passenger Vehicles - Large 2 Axle Vehicles - 3 Axle Vehicles - 4+ Axle Trucks

Start Time	Sycamore Canyon Blvd Southbound				Box Springs Road Westbound				Sycamore Canyon Blvd Northbound				Box Springs Road Eastbound				Int. Total
	Left	Thru	Right	App. Total	Left	Thru	Right	App. Total	Left	Thru	Right	App. Total	Left	Thru	Right	App. Total	
04:00 PM	44	60	10	114	18	18	17	53	42	43	132	217	2	14	25	41	425
04:15 PM	53	63	7	123	19	13	13	45	40	46	109	195	4	25	24	53	416
04:30 PM	52	70	5	127	30	18	19	67	43	48	144	235	7	21	21	49	478
04:45 PM	80	73	8	161	19	10	10	39	47	42	96	185	3	12	27	42	427
Total	229	266	30	525	86	59	59	204	172	179	481	832	16	72	97	185	1746
05:00 PM	64	75	10	149	28	20	19	67	46	54	157	257	2	24	22	48	521
05:15 PM	96	88	9	193	14	24	16	54	55	41	140	236	6	17	16	39	522
05:30 PM	90	75	16	181	16	18	28	62	41	24	118	183	3	20	20	43	469
05:45 PM	97	73	9	179	18	16	17	51	28	26	106	160	2	21	18	41	431
Total	347	311	44	702	76	78	80	234	170	145	521	836	13	82	76	171	1943
Grand Total	576	577	74	1227	162	137	139	438	342	324	1002	1668	29	154	173	356	3689
Apprch %	46.9	47	6		37	31.3	31.7		20.5	19.4	60.1		8.1	43.3	48.6		
Total %	15.6	15.6	2	33.3	4.4	3.7	3.8	11.9	9.3	8.8	27.2	45.2	0.8	4.2	4.7	9.7	
Passenger Vehicles	570	568	74	1212	149	133	134	416	336	321	914	1571	25	145	169	339	3538
% Passenger Vehicles	99	98.4	100	98.8	92	97.1	96.4	95	98.2	99.1	91.2	94.2	86.2	94.2	97.7	95.2	95.9
Large 2 Axle Vehicles	6	8	0	14	13	4	5	22	6	3	45	54	4	9	4	17	107
% Large 2 Axle Vehicles	1	1.4	0	1.1	8	2.9	3.6	5	1.8	0.9	4.5	3.2	13.8	5.8	2.3	4.8	2.9
3 Axle Vehicles	0	1	0	1	0	0	0	0	0	0	7	7	0	0	0	0	8
% 3 Axle Vehicles	0	0.2	0	0.1	0	0	0	0	0	0	0.7	0.4	0	0	0	0	0.2
4+ Axle Trucks	0	0	0	0	0	0	0	0	0	0	36	36	0	0	0	0	36
% 4+ Axle Trucks	0	0	0	0	0	0	0	0	0	0	3.6	2.2	0	0	0	0	1

Start Time	Sycamore Canyon Blvd Southbound				Box Springs Road Westbound				Sycamore Canyon Blvd Northbound				Box Springs Road Eastbound				Int. Total
	Left	Thru	Right	App. Total	Left	Thru	Right	App. Total	Left	Thru	Right	App. Total	Left	Thru	Right	App. Total	
04:30 PM	52	70	5	127	30	18	19	67	43	48	144	235	7	21	21	49	478
04:45 PM	80	73	8	161	19	10	10	39	47	42	96	185	3	12	27	42	427
05:00 PM	64	75	10	149	28	20	19	67	46	54	157	257	2	24	22	48	521
05:15 PM	96	88	9	193	14	24	16	54	55	41	140	236	6	17	16	39	522
Total Volume	292	306	32	630	91	72	64	227	191	185	537	913	18	74	86	178	1948
% App. Total	46.3	48.6	5.1		40.1	31.7	28.2		20.9	20.3	58.8		10.1	41.6	48.3		
PHF	.760	.869	.800	.816	.758	.750	.842	.847	.868	.856	.855	.888	.643	.771	.796	.908	.933

Peak Hour Analysis From 04:00 PM to 05:45 PM - Peak 1 of 1

Peak Hour for Entire Intersection Begins at 04:30 PM

City of Riverside
 N/S: Sycamore Canyon Blvd
 E/W: Box Springs Road
 Weather: Clear

File Name : RIVSCBRPM
 Site Code : 06715392
 Start Date : 7/7/2015
 Page No : 2

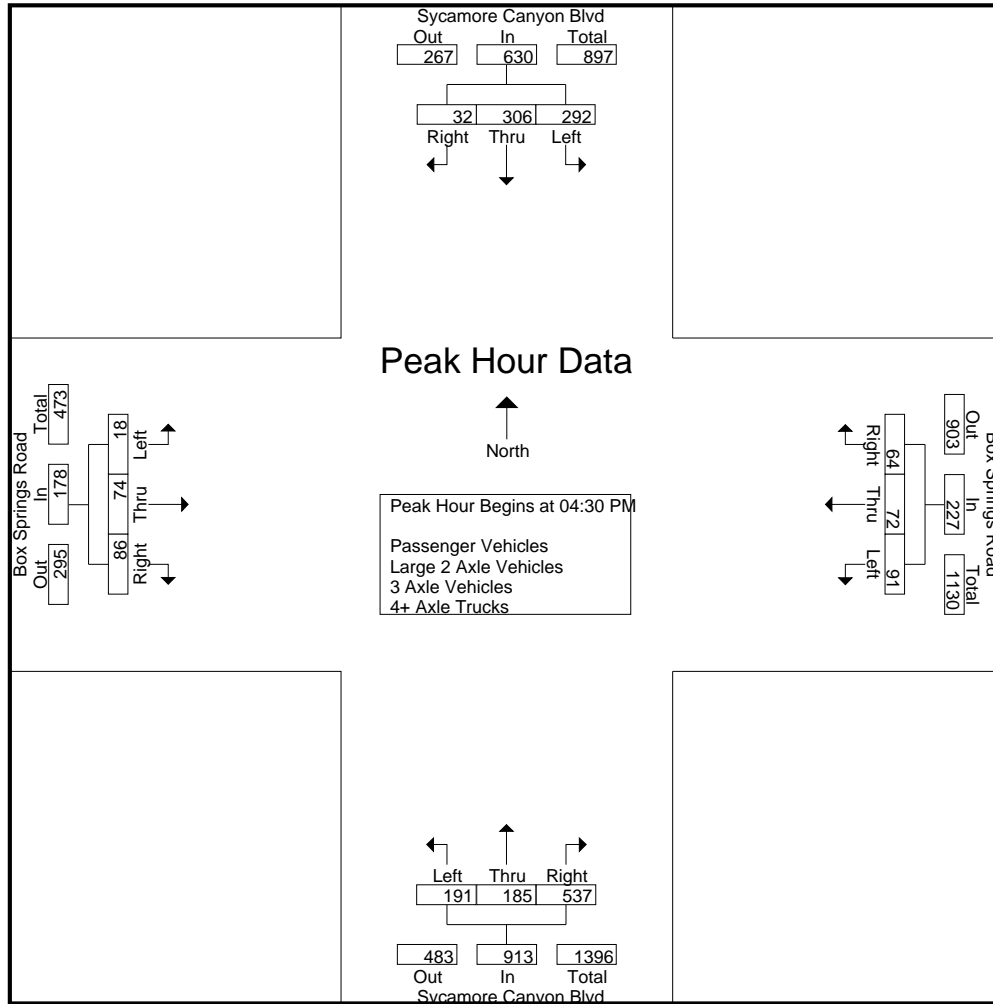

Peak Hour Analysis From 04:00 PM to 05:45 PM - Peak 1 of 1
 Peak Hour for Each Approach Begins at:

	05:00 PM				05:00 PM				04:30 PM				04:15 PM			
+0 mins.	64	75	10	149	28	20	19	67	43	48	144	235	4	25	24	53
+15 mins.	96	88	9	193	14	24	16	54	47	42	96	185	7	21	21	49
+30 mins.	90	75	16	181	16	18	28	62	46	54	157	257	3	12	27	42
+45 mins.	97	73	9	179	18	16	17	51	55	41	140	236	2	24	22	48
Total Volume	347	311	44	702	76	78	80	234	191	185	537	913	16	82	94	192
% App. Total	49.4	44.3	6.3		32.5	33.3	34.2		20.9	20.3	58.8		8.3	42.7	49	
PHF	.894	.884	.688	.909	.679	.813	.714	.873	.868	.856	.855	.888	.571	.820	.870	.906

City of Riverside
 N/S: Sycamore Canyon Blvd
 E/W: Box Springs Road
 Weather: Clear

File Name : RIVSCBRPM
 Site Code : 06715392
 Start Date : 7/7/2015
 Page No : 1

Groups Printed- Passenger Vehicles

Start Time	Sycamore Canyon Blvd Southbound				Box Springs Road Westbound				Sycamore Canyon Blvd Northbound				Box Springs Road Eastbound				Int. Total
	Left	Thru	Right	App. Total	Left	Thru	Right	App. Total	Left	Thru	Right	App. Total	Left	Thru	Right	App. Total	
04:00 PM	44	59	10	113	18	18	16	52	41	42	117	200	2	11	22	35	400
04:15 PM	52	62	7	121	15	13	11	39	40	46	98	184	4	25	23	52	396
04:30 PM	51	69	5	125	28	18	19	65	43	47	136	226	5	19	21	45	461
04:45 PM	79	71	8	158	16	10	9	35	45	41	84	170	3	12	27	42	405
Total	226	261	30	517	77	59	55	191	169	176	435	780	14	67	93	174	1662
05:00 PM	63	73	10	146	27	19	19	65	45	54	142	241	1	22	22	45	497
05:15 PM	95	87	9	191	13	23	15	51	53	41	127	221	6	16	16	38	501
05:30 PM	89	75	16	180	15	18	28	61	41	24	110	175	2	20	20	42	458
05:45 PM	97	72	9	178	17	14	17	48	28	26	100	154	2	20	18	40	420
Total	344	307	44	695	72	74	79	225	167	145	479	791	11	78	76	165	1876
Grand Total	570	568	74	1212	149	133	134	416	336	321	914	1571	25	145	169	339	3538
Apprch %	47	46.9	6.1		35.8	32	32.2		21.4	20.4	58.2		7.4	42.8	49.9		
Total %	16.1	16.1	2.1	34.3	4.2	3.8	3.8	11.8	9.5	9.1	25.8	44.4	0.7	4.1	4.8	9.6	

Start Time	Sycamore Canyon Blvd Southbound				Box Springs Road Westbound				Sycamore Canyon Blvd Northbound				Box Springs Road Eastbound				Int. Total
	Left	Thru	Right	App. Total	Left	Thru	Right	App. Total	Left	Thru	Right	App. Total	Left	Thru	Right	App. Total	
04:30 PM	51	69	5	125	28	18	19	65	43	47	136	226	5	19	21	45	461
04:45 PM	79	71	8	158	16	10	9	35	45	41	84	170	3	12	27	42	405
05:00 PM	63	73	10	146	27	19	19	65	45	54	142	241	1	22	22	45	497
05:15 PM	95	87	9	191	13	23	15	51	53	41	127	221	6	16	16	38	501
Total Volume	288	300	32	620	84	70	62	216	186	183	489	858	15	69	86	170	1864
% App. Total	46.5	48.4	5.2		38.9	32.4	28.7		21.7	21.3	57		8.8	40.6	50.6		
PHF	.758	.862	.800	.812	.750	.761	.816	.831	.877	.847	.861	.890	.625	.784	.796	.944	.930

Peak Hour Analysis From 04:30 PM to 05:15 PM - Peak 1 of 1

Peak Hour for Entire Intersection Begins at 04:30 PM

City of Riverside
 N/S: Sycamore Canyon Blvd
 E/W: Box Springs Road
 Weather: Clear

File Name : RIVSCBRPM
 Site Code : 06715392
 Start Date : 7/7/2015
 Page No : 2

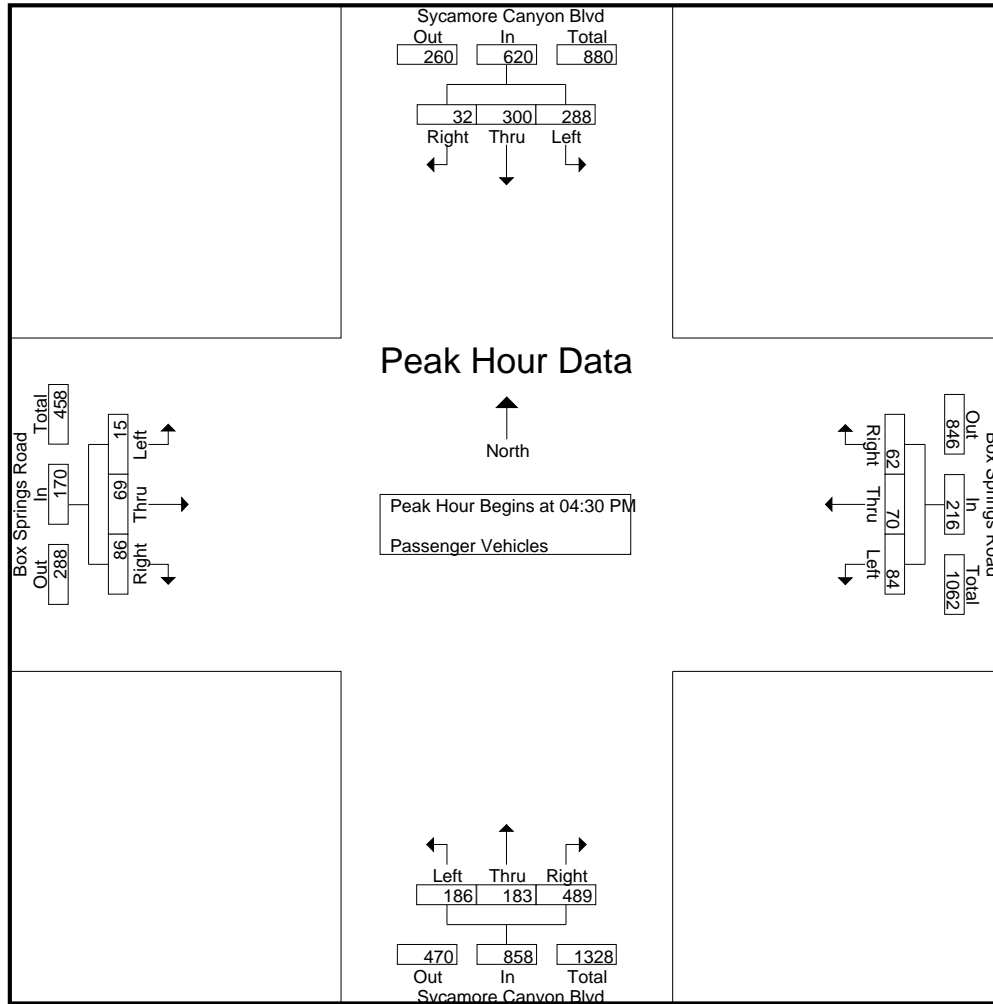

Peak Hour Analysis From 04:30 PM to 05:15 PM - Peak 1 of 1
 Peak Hour for Each Approach Begins at:

	04:30 PM				04:30 PM				04:30 PM				04:30 PM			
+0 mins.	51	69	5	125	28	18	19	65	43	47	136	226	5	19	21	45
+15 mins.	79	71	8	158	16	10	9	35	45	41	84	170	3	12	27	42
+30 mins.	63	73	10	146	27	19	19	65	45	54	142	241	1	22	22	45
+45 mins.	95	87	9	191	13	23	15	51	53	41	127	221	6	16	16	38
Total Volume	288	300	32	620	84	70	62	216	186	183	489	858	15	69	86	170
% App. Total	46.5	48.4	5.2		38.9	32.4	28.7		21.7	21.3	57		8.8	40.6	50.6	
PHF	.758	.862	.800	.812	.750	.761	.816	.831	.877	.847	.861	.890	.625	.784	.796	.944

City of Riverside
 N/S: Sycamore Canyon Blvd
 E/W: Box Springs Road
 Weather: Clear

File Name : RIVSCBRPM
 Site Code : 06715392
 Start Date : 7/7/2015
 Page No : 1

Groups Printed- Large 2 Axle Vehicles

Start Time	Sycamore Canyon Blvd Southbound				Box Springs Road Westbound				Sycamore Canyon Blvd Northbound				Box Springs Road Eastbound				Int. Total
	Left	Thru	Right	App. Total	Left	Thru	Right	App. Total	Left	Thru	Right	App. Total	Left	Thru	Right	App. Total	
04:00 PM	0	1	0	1	0	0	1	1	1	1	8	10	0	3	3	6	18
04:15 PM	1	1	0	2	4	0	2	6	0	0	4	4	0	0	1	1	13
04:30 PM	1	1	0	2	2	0	0	2	0	1	5	6	2	2	0	4	14
04:45 PM	1	1	0	2	3	0	1	4	2	1	7	10	0	0	0	0	16
Total	3	4	0	7	9	0	4	13	3	3	24	30	2	5	4	11	61
05:00 PM	1	2	0	3	1	1	0	2	1	0	8	9	1	2	0	3	17
05:15 PM	1	1	0	2	1	1	1	3	2	0	8	10	0	1	0	1	16
05:30 PM	1	0	0	1	1	0	0	1	0	0	3	3	1	0	0	1	6
05:45 PM	0	1	0	1	1	2	0	3	0	0	2	2	0	1	0	1	7
Total	3	4	0	7	4	4	1	9	3	0	21	24	2	4	0	6	46
Grand Total	6	8	0	14	13	4	5	22	6	3	45	54	4	9	4	17	107
Apprch %	42.9	57.1	0		59.1	18.2	22.7		11.1	5.6	83.3		23.5	52.9	23.5		
Total %	5.6	7.5	0	13.1	12.1	3.7	4.7	20.6	5.6	2.8	42.1	50.5	3.7	8.4	3.7	15.9	

Start Time	Sycamore Canyon Blvd Southbound				Box Springs Road Westbound				Sycamore Canyon Blvd Northbound				Box Springs Road Eastbound				Int. Total
	Left	Thru	Right	App. Total	Left	Thru	Right	App. Total	Left	Thru	Right	App. Total	Left	Thru	Right	App. Total	
04:30 PM	1	1	0	2	2	0	0	2	0	1	5	6	2	2	0	4	14
04:45 PM	1	1	0	2	3	0	1	4	2	1	7	10	0	0	0	0	16
05:00 PM	1	2	0	3	1	1	0	2	1	0	8	9	1	2	0	3	17
05:15 PM	1	1	0	2	1	1	1	3	2	0	8	10	0	1	0	1	16
Total Volume	4	5	0	9	7	2	2	11	5	2	28	35	3	5	0	8	63
% App. Total	44.4	55.6	0		63.6	18.2	18.2		14.3	5.7	80		37.5	62.5	0		
PHF	1.00	.625	.000	.750	.583	.500	.500	.688	.625	.500	.875	.875	.375	.625	.000	.500	.926

Peak Hour Analysis From 04:30 PM to 05:15 PM - Peak 1 of 1

Peak Hour for Entire Intersection Begins at 04:30 PM

City of Riverside
 N/S: Sycamore Canyon Blvd
 E/W: Box Springs Road
 Weather: Clear

File Name : RIVSCBRPM
 Site Code : 06715392
 Start Date : 7/7/2015
 Page No : 2

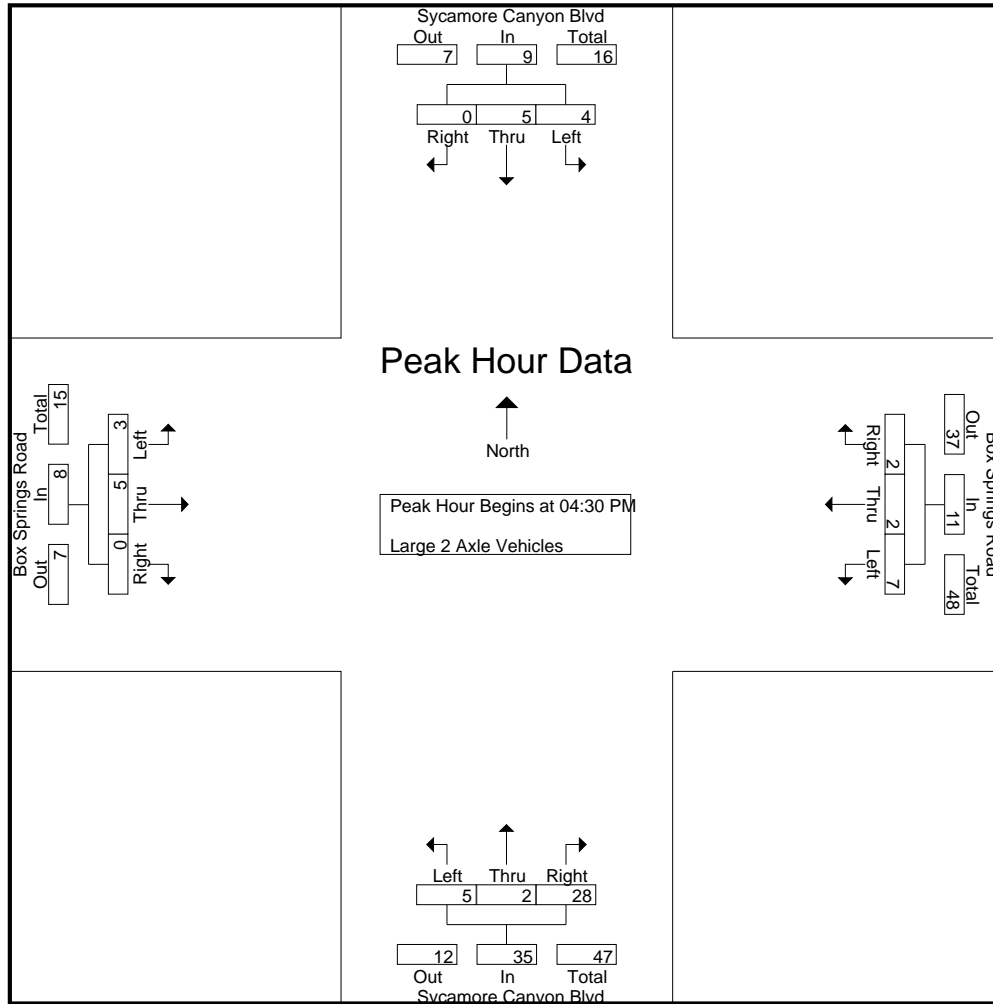

Peak Hour Analysis From 04:30 PM to 05:15 PM - Peak 1 of 1
 Peak Hour for Each Approach Begins at:

	04:30 PM				04:30 PM				04:30 PM				04:30 PM			
+0 mins.	1	1	0	2	2	0	0	2	0	1	5	6	2	2	0	4
+15 mins.	1	1	0	2	3	0	1	4	2	1	7	10	0	0	0	0
+30 mins.	1	2	0	3	1	1	0	2	1	0	8	9	1	2	0	3
+45 mins.	1	1	0	2	1	1	1	3	2	0	8	10	0	1	0	1
Total Volume	4	5	0	9	7	2	2	11	5	2	28	35	3	5	0	8
% App. Total	44.4	55.6	0		63.6	18.2	18.2		14.3	5.7	80		37.5	62.5	0	
PHF	1.00	.625	.000	.750	.583	.500	.500	.688	.625	.500	.875	.875	.375	.625	.000	.500
	0															

City of Riverside
 N/S: Sycamore Canyon Blvd
 E/W: Box Springs Road
 Weather: Clear

File Name : RIVSCBRPM
 Site Code : 06715392
 Start Date : 7/7/2015
 Page No : 1

Groups Printed- 3 Axle Vehicles

Start Time	Sycamore Canyon Blvd Southbound				Box Springs Road Westbound				Sycamore Canyon Blvd Northbound				Box Springs Road Eastbound				Int. Total
	Left	Thru	Right	App. Total	Left	Thru	Right	App. Total	Left	Thru	Right	App. Total	Left	Thru	Right	App. Total	
04:00 PM	0	0	0	0	0	0	0	0	0	0	1	1	0	0	0	0	1
04:15 PM	0	0	0	0	0	0	0	0	0	0	2	2	0	0	0	0	2
04:30 PM	0	0	0	0	0	0	0	0	0	0	0	0	0	0	0	0	0
04:45 PM	0	1	0	1	0	0	0	0	0	0	0	0	0	0	0	0	1
Total	0	1	0	1	0	0	0	0	0	0	3	3	0	0	0	0	4
05:00 PM	0	0	0	0	0	0	0	0	0	0	1	1	0	0	0	0	1
05:15 PM	0	0	0	0	0	0	0	0	0	0	1	1	0	0	0	0	1
05:30 PM	0	0	0	0	0	0	0	0	0	0	1	1	0	0	0	0	1
05:45 PM	0	0	0	0	0	0	0	0	0	0	1	1	0	0	0	0	1
Total	0	0	0	0	0	0	0	0	0	0	4	4	0	0	0	0	4
Grand Total	0	1	0	1	0	0	0	0	0	0	7	7	0	0	0	0	8
Apprch %	0	100	0		0	0	0		0	0	100		0	0	0		
Total %	0	12.5	0	12.5	0	0	0	0	0	0	87.5	87.5	0	0	0	0	

Start Time	Sycamore Canyon Blvd Southbound				Box Springs Road Westbound				Sycamore Canyon Blvd Northbound				Box Springs Road Eastbound				Int. Total
	Left	Thru	Right	App. Total	Left	Thru	Right	App. Total	Left	Thru	Right	App. Total	Left	Thru	Right	App. Total	
04:30 PM	0	0	0	0	0	0	0	0	0	0	0	0	0	0	0	0	0
04:45 PM	0	1	0	1	0	0	0	0	0	0	0	0	0	0	0	0	1
05:00 PM	0	0	0	0	0	0	0	0	0	0	1	1	0	0	0	0	1
05:15 PM	0	0	0	0	0	0	0	0	0	0	1	1	0	0	0	0	1
Total	0	1	0	1	0	0	0	0	0	0	2	2	0	0	0	0	3
Volume % App. Total	0	100	0		0	0	0		0	0	100		0	0	0		
PHF	.000	.250	.000	.250	.000	.000	.000	.000	.000	.000	.500	.500	.000	.000	.000	.000	.750

Peak Hour Analysis From 04:30 PM to 05:15 PM - Peak 1 of 1

Peak Hour for Entire Intersection Begins at 04:30 PM

City of Riverside
 N/S: Sycamore Canyon Blvd
 E/W: Box Springs Road
 Weather: Clear

File Name : RIVSCBRPM
 Site Code : 06715392
 Start Date : 7/7/2015
 Page No : 2

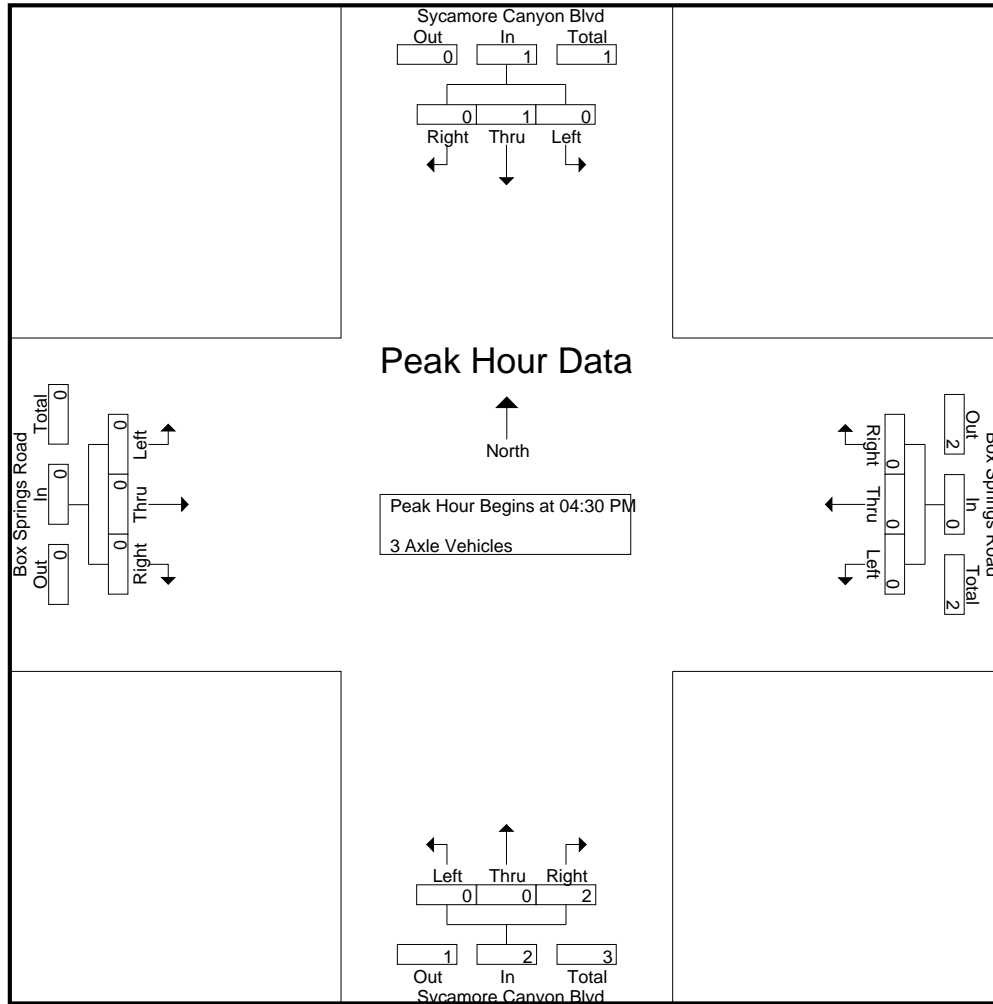

Peak Hour Analysis From 04:30 PM to 05:15 PM - Peak 1 of 1
 Peak Hour for Each Approach Begins at:

	04:30 PM				04:30 PM				04:30 PM				04:30 PM			
+0 mins.	0	0	0	0	0	0	0	0	0	0	0	0	0	0	0	0
+15 mins.	0	1	0	1	0	0	0	0	0	0	0	0	0	0	0	0
+30 mins.	0	0	0	0	0	0	0	0	0	0	1	1	0	0	0	0
+45 mins.	0	0	0	0	0	0	0	0	0	0	1	1	0	0	0	0
Total Volume	0	1	0	1	0	0	0	0	0	0	2	2	0	0	0	0
% App. Total	0	100	0		0	0	0		0	0	100		0	0	0	
PHF	.000	.250	.000	.250	.000	.000	.000	.000	.000	.000	.500	.500	.000	.000	.000	.000

City of Riverside
 N/S: Sycamore Canyon Blvd
 E/W: Box Springs Road
 Weather: Clear

File Name : RIVSCBRPM
 Site Code : 06715392
 Start Date : 7/7/2015
 Page No : 1

Groups Printed- 4+ Axle Trucks

Start Time	Sycamore Canyon Blvd Southbound				Box Springs Road Westbound				Sycamore Canyon Blvd Northbound				Box Springs Road Eastbound				Int. Total
	Left	Thru	Right	App. Total	Left	Thru	Right	App. Total	Left	Thru	Right	App. Total	Left	Thru	Right	App. Total	
04:00 PM	0	0	0	0	0	0	0	0	0	0	6	6	0	0	0	0	6
04:15 PM	0	0	0	0	0	0	0	0	0	0	5	5	0	0	0	0	5
04:30 PM	0	0	0	0	0	0	0	0	0	0	3	3	0	0	0	0	3
04:45 PM	0	0	0	0	0	0	0	0	0	0	5	5	0	0	0	0	5
Total	0	0	0	0	0	0	0	0	0	0	19	19	0	0	0	0	19
05:00 PM	0	0	0	0	0	0	0	0	0	0	6	6	0	0	0	0	6
05:15 PM	0	0	0	0	0	0	0	0	0	0	4	4	0	0	0	0	4
05:30 PM	0	0	0	0	0	0	0	0	0	0	4	4	0	0	0	0	4
05:45 PM	0	0	0	0	0	0	0	0	0	0	3	3	0	0	0	0	3
Total	0	0	0	0	0	0	0	0	0	0	17	17	0	0	0	0	17
Grand Total	0	0	0	0	0	0	0	0	0	0	36	36	0	0	0	0	36
Apprch %	0	0	0	0	0	0	0	0	0	0	100	100	0	0	0	0	
Total %	0	0	0	0	0	0	0	0	0	0	100	100	0	0	0	0	

Start Time	Sycamore Canyon Blvd Southbound				Box Springs Road Westbound				Sycamore Canyon Blvd Northbound				Box Springs Road Eastbound				Int. Total
	Left	Thru	Right	App. Total	Left	Thru	Right	App. Total	Left	Thru	Right	App. Total	Left	Thru	Right	App. Total	
04:30 PM	0	0	0	0	0	0	0	0	0	0	3	3	0	0	0	0	3
04:45 PM	0	0	0	0	0	0	0	0	0	0	5	5	0	0	0	0	5
05:00 PM	0	0	0	0	0	0	0	0	0	0	6	6	0	0	0	0	6
05:15 PM	0	0	0	0	0	0	0	0	0	0	4	4	0	0	0	0	4
Total	0	0	0	0	0	0	0	0	0	0	18	18	0	0	0	0	18
Volume	0	0	0	0	0	0	0	0	0	0	100	100	0	0	0	0	
% App. Total	0	0	0	0	0	0	0	0	0	0	100	100	0	0	0	0	
PHF	.000	.000	.000	.000	.000	.000	.000	.000	.000	.000	.750	.750	.000	.000	.000	.000	.750

Peak Hour Analysis From 04:30 PM to 05:15 PM - Peak 1 of 1

Peak Hour for Entire Intersection Begins at 04:30 PM

City of Riverside
 N/S: Sycamore Canyon Blvd
 E/W: Box Springs Road
 Weather: Clear

File Name : RIVSCBRPM
 Site Code : 06715392
 Start Date : 7/7/2015
 Page No : 2

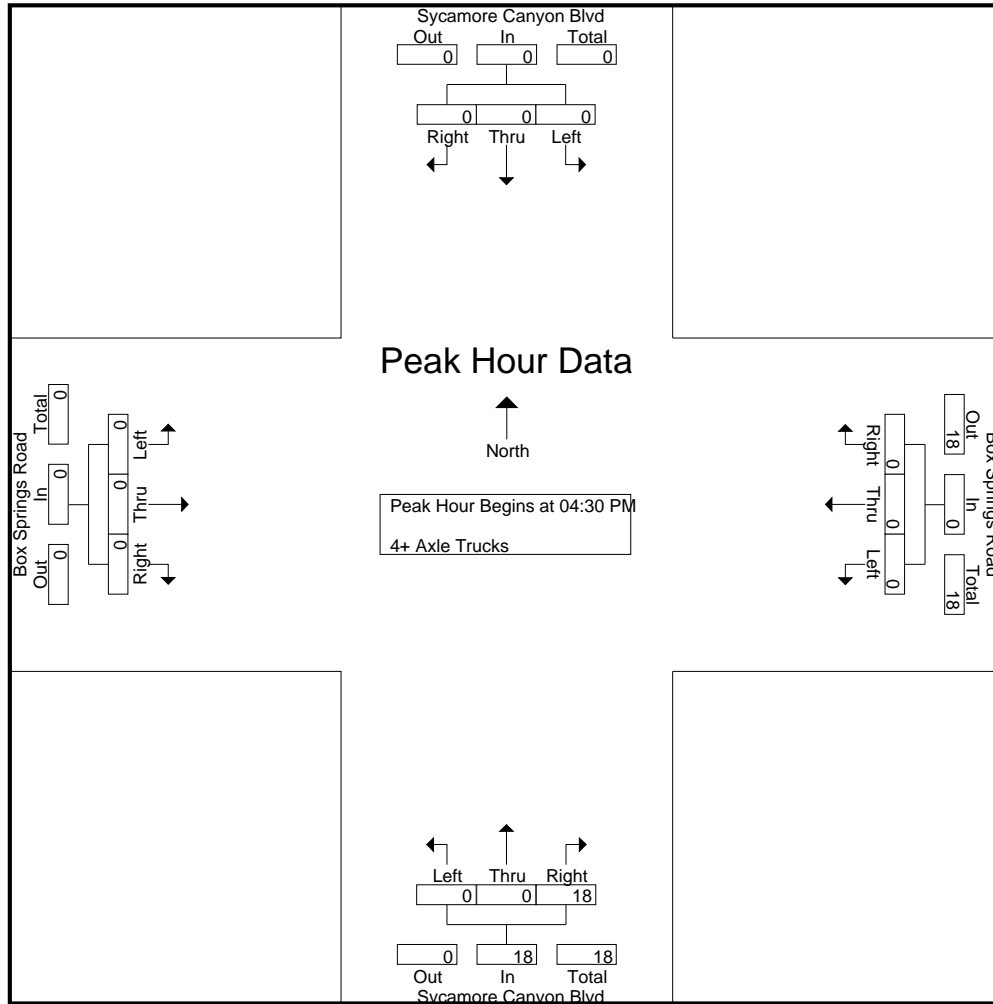

Peak Hour Analysis From 04:30 PM to 05:15 PM - Peak 1 of 1
 Peak Hour for Each Approach Begins at:

	04:30 PM				04:30 PM				04:30 PM				04:30 PM			
+0 mins.	0	0	0	0	0	0	0	0	0	0	3	3	0	0	0	0
+15 mins.	0	0	0	0	0	0	0	0	0	0	5	5	0	0	0	0
+30 mins.	0	0	0	0	0	0	0	0	0	0	6	6	0	0	0	0
+45 mins.	0	0	0	0	0	0	0	0	0	0	4	4	0	0	0	0
Total Volume	0	0	0	0	0	0	0	0	0	0	18	18	0	0	0	0
% App. Total	0	0	0	0	0	0	0	0	0	0	100	100	0	0	0	0
PHF	.000	.000	.000	.000	.000	.000	.000	.000	.000	.000	.750	.750	.000	.000	.000	.000

Counts Unlimited Inc
PO Box 1178
Corona, CA 92878
(951) 268-6268

City of Riverside
N/S: Sycamore Canyon Blvd
E/W: I-215 Southbound Ramp
Weather: Clear

File Name : RIV215SSCAM
Site Code : 06715392
Start Date : 7/7/2015
Page No : 1

Groups Printed- Passenger Vehicles - Large 2 Axle Vehicles - 3 Axle Vehicles - 4+ Axle Trucks

Start Time	Sycamore Canyon Blvd Southbound			I-215 Southbound Ramp Westbound			Sycamore Canyon Blvd Northbound			Int. Total
	Left	Thru	App. Total	Left	Right	App. Total	Thru	Right	App. Total	
07:00 AM	26	39	65	52	17	69	266	4	270	404
07:15 AM	26	48	74	75	32	107	335	6	341	522
07:30 AM	36	48	84	67	27	94	334	2	336	514
07:45 AM	25	66	91	89	36	125	288	8	296	512
Total	113	201	314	283	112	395	1223	20	1243	1952
08:00 AM	34	48	82	57	24	81	269	9	278	441
08:15 AM	32	51	83	32	29	61	233	11	244	388
08:30 AM	24	43	67	39	31	70	227	8	235	372
08:45 AM	31	51	82	53	22	75	139	15	154	311
Total	121	193	314	181	106	287	868	43	911	1512
Grand Total	234	394	628	464	218	682	2091	63	2154	3464
Apprch %	37.3	62.7		68	32		97.1	2.9		
Total %	6.8	11.4	18.1	13.4	6.3	19.7	60.4	1.8	62.2	
Passenger Vehicles	214	370	584	427	203	630	1940	56	1996	3210
% Passenger Vehicles	91.5	93.9	93	92	93.1	92.4	92.8	88.9	92.7	92.7
Large 2 Axle Vehicles	19	22	41	15	13	28	53	4	57	126
% Large 2 Axle Vehicles	8.1	5.6	6.5	3.2	6	4.1	2.5	6.3	2.6	3.6
3 Axle Vehicles	1	2	3	3	1	4	14	0	14	21
% 3 Axle Vehicles	0.4	0.5	0.5	0.6	0.5	0.6	0.7	0	0.6	0.6
4+ Axle Trucks	0	0	0	19	1	20	84	3	87	107
% 4+ Axle Trucks	0	0	0	4.1	0.5	2.9	4	4.8	4	3.1

Start Time	Sycamore Canyon Blvd Southbound			I-215 Southbound Ramp Westbound			Sycamore Canyon Blvd Northbound			Int. Total
	Left	Thru	App. Total	Left	Right	App. Total	Thru	Right	App. Total	
Peak Hour Analysis From 07:00 AM to 08:45 AM - Peak 1 of 1										
Peak Hour for Entire Intersection Begins at 07:15 AM										
07:15 AM	26	48	74	75	32	107	335	6	341	522
07:30 AM	36	48	84	67	27	94	334	2	336	514
07:45 AM	25	66	91	89	36	125	288	8	296	512
08:00 AM	34	48	82	57	24	81	269	9	278	441
Total Volume	121	210	331	288	119	407	1226	25	1251	1989
% App. Total	36.6	63.4		70.8	29.2		98	2		
PHF	.840	.795	.909	.809	.826	.814	.915	.694	.917	.953

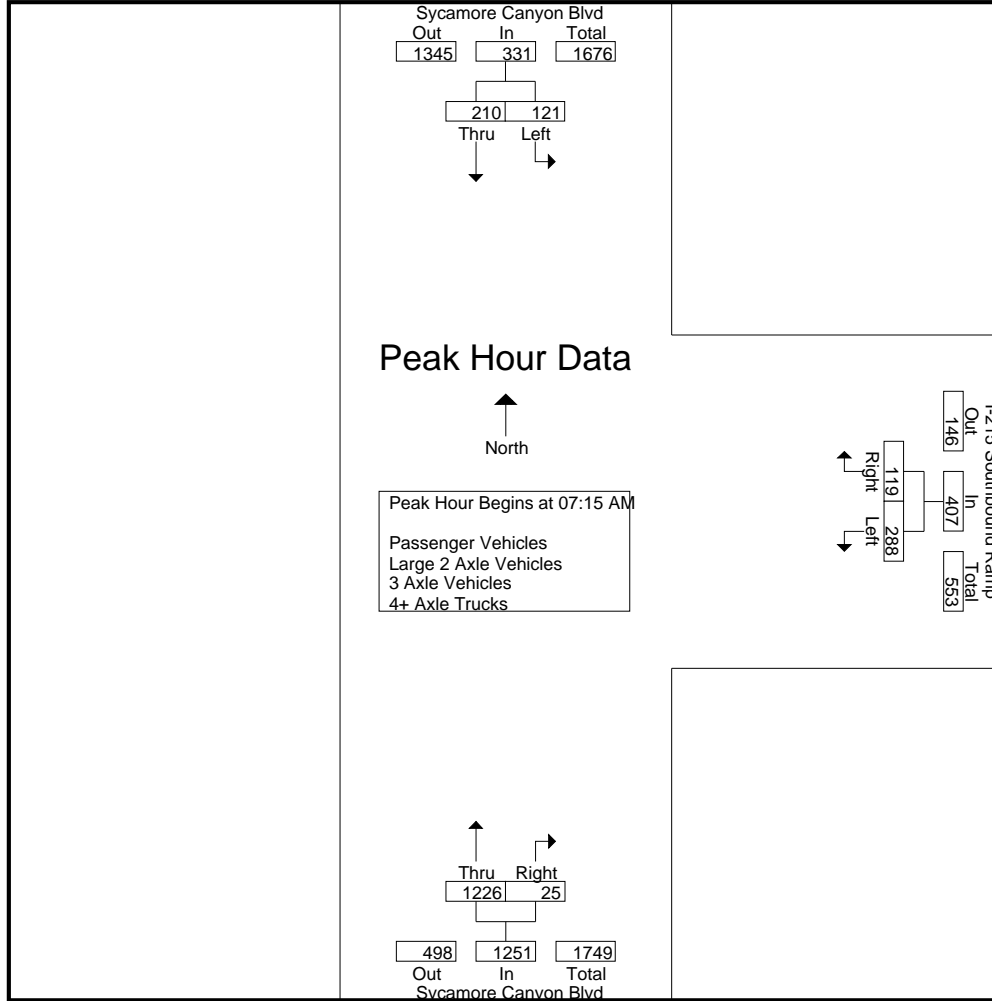

Peak Hour Analysis From 07:00 AM to 08:45 AM - Peak 1 of 1
 Peak Hour for Each Approach Begins at:

	07:30 AM			07:15 AM			07:15 AM		
+0 mins.	36	48	84	75	32	107	335	6	341
+15 mins.	25	66	91	67	27	94	334	2	336
+30 mins.	34	48	82	89	36	125	288	8	296
+45 mins.	32	51	83	57	24	81	269	9	278
Total Volume	127	213	340	288	119	407	1226	25	1251
% App. Total	37.4	62.6		70.8	29.2		98	2	
PHF	.882	.807	.934	.809	.826	.814	.915	.694	.917

Counts Unlimited Inc
PO Box 1178
Corona, CA 92878
(951) 268-6268

City of Riverside
 N/S: Sycamore Canyon Blvd
 EW: I-215 Southbound Ramp
 Weather: Clear

File Name : RIV215SSCAM
 Site Code : 06715392
 Start Date : 7/7/2015
 Page No : 1

Groups Printed- Passenger Vehicles

Start Time	Sycamore Canyon Blvd Southbound			I-215 Southbound Ramp Westbound			Sycamore Canyon Blvd Northbound			Int. Total
	Left	Thru	App. Total	Left	Right	App. Total	Thru	Right	App. Total	
07:00 AM	26	34	60	49	16	65	246	3	249	374
07:15 AM	24	44	68	68	30	98	314	6	320	486
07:30 AM	35	45	80	62	26	88	312	0	312	480
07:45 AM	24	65	89	83	36	119	265	8	273	481
Total	109	188	297	262	108	370	1137	17	1154	1821
08:00 AM	27	43	70	56	22	78	246	8	254	402
08:15 AM	27	50	77	26	22	48	213	10	223	348
08:30 AM	20	40	60	35	30	65	212	7	219	344
08:45 AM	31	49	80	48	21	69	132	14	146	295
Total	105	182	287	165	95	260	803	39	842	1389
Grand Total	214	370	584	427	203	630	1940	56	1996	3210
Apprch %	36.6	63.4		67.8	32.2		97.2	2.8		
Total %	6.7	11.5	18.2	13.3	6.3	19.6	60.4	1.7	62.2	

Start Time	Sycamore Canyon Blvd Southbound			I-215 Southbound Ramp Westbound			Sycamore Canyon Blvd Northbound			Int. Total
	Left	Thru	App. Total	Left	Right	App. Total	Thru	Right	App. Total	
Peak Hour Analysis From 07:15 AM to 08:00 AM - Peak 1 of 1										
Peak Hour for Entire Intersection Begins at 07:15 AM										
07:15 AM	24	44	68	68	30	98	314	6	320	486
07:30 AM	35	45	80	62	26	88	312	0	312	480
07:45 AM	24	65	89	83	36	119	265	8	273	481
08:00 AM	27	43	70	56	22	78	246	8	254	402
Total Volume	110	197	307	269	114	383	1137	22	1159	1849
% App. Total	35.8	64.2		70.2	29.8		98.1	1.9		
PHF	.786	.758	.862	.810	.792	.805	.905	.688	.905	.951

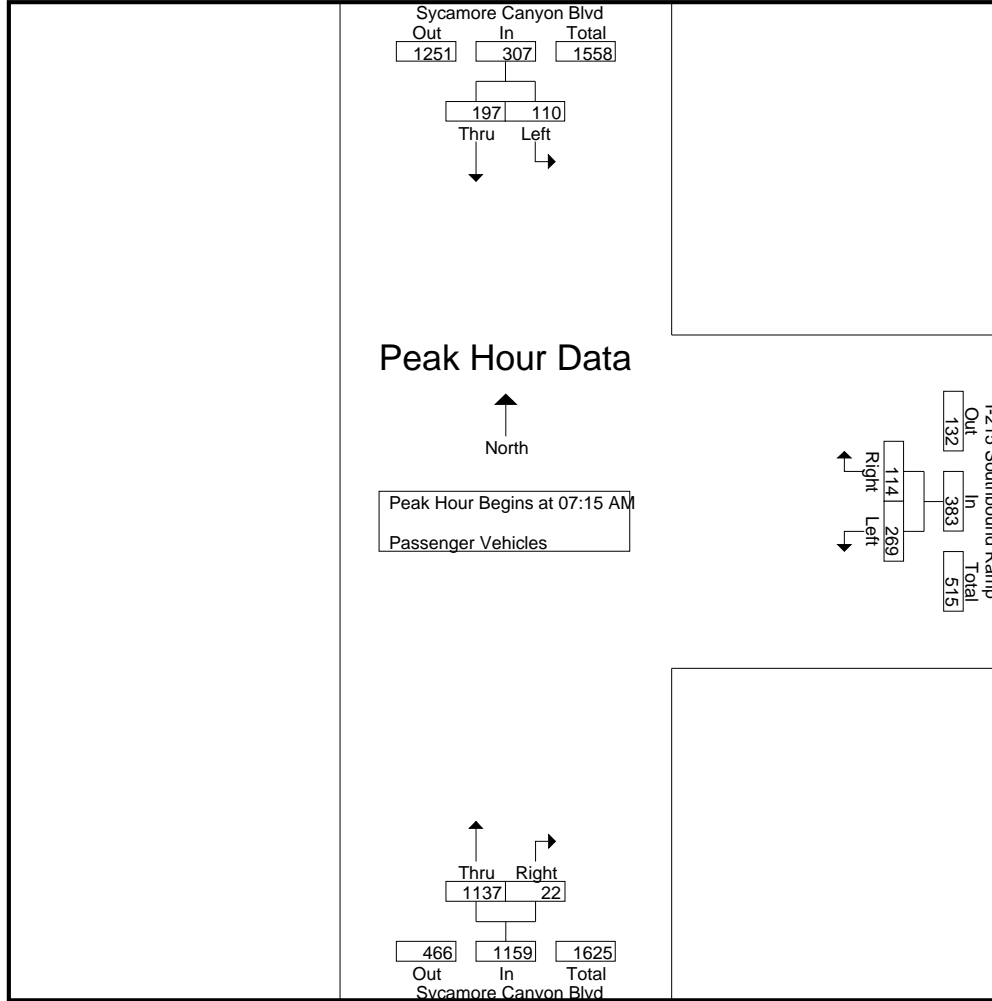

Peak Hour Analysis From 07:15 AM to 08:00 AM - Peak 1 of 1
 Peak Hour for Each Approach Begins at:

	07:15 AM			07:15 AM			07:15 AM		
+0 mins.	24	44	68	68	30	98	314	6	320
+15 mins.	35	45	80	62	26	88	312	0	312
+30 mins.	24	65	89	83	36	119	265	8	273
+45 mins.	27	43	70	56	22	78	246	8	254
Total Volume	110	197	307	269	114	383	1137	22	1159
% App. Total	35.8	64.2		70.2	29.8		98.1	1.9	
PHF	.786	.758	.862	.810	.792	.805	.905	.688	.905

Counts Unlimited Inc
 PO Box 1178
 Corona, CA 92878
 (951) 268-6268

City of Riverside
 N/S: Sycamore Canyon Blvd
 E/W: I-215 Southbound Ramp
 Weather: Clear

File Name : RIV215SSCAM
 Site Code : 06715392
 Start Date : 7/7/2015
 Page No : 1

Groups Printed- Large 2 Axle Vehicles

Start Time	Sycamore Canyon Blvd Southbound			I-215 Southbound Ramp Westbound			Sycamore Canyon Blvd Northbound			Int. Total
	Left	Thru	App. Total	Left	Right	App. Total	Thru	Right	App. Total	
07:00 AM	0	4	4	1	1	2	8	0	8	14
07:15 AM	2	3	5	0	2	2	8	0	8	15
07:30 AM	1	3	4	0	0	0	4	1	5	9
07:45 AM	1	1	2	4	0	4	9	0	9	15
Total	4	11	15	5	3	8	29	1	30	53
08:00 AM	7	5	12	0	2	2	7	1	8	22
08:15 AM	4	1	5	5	7	12	6	0	6	23
08:30 AM	4	3	7	3	0	3	5	1	6	16
08:45 AM	0	2	2	2	1	3	6	1	7	12
Total	15	11	26	10	10	20	24	3	27	73
Grand Total	19	22	41	15	13	28	53	4	57	126
Apprch %	46.3	53.7		53.6	46.4		93	7		
Total %	15.1	17.5	32.5	11.9	10.3	22.2	42.1	3.2	45.2	

Start Time	Sycamore Canyon Blvd Southbound			I-215 Southbound Ramp Westbound			Sycamore Canyon Blvd Northbound			Int. Total
	Left	Thru	App. Total	Left	Right	App. Total	Thru	Right	App. Total	
Peak Hour Analysis From 07:15 AM to 08:00 AM - Peak 1 of 1										
Peak Hour for Entire Intersection Begins at 07:15 AM										
07:15 AM	2	3	5	0	2	2	8	0	8	15
07:30 AM	1	3	4	0	0	0	4	1	5	9
07:45 AM	1	1	2	4	0	4	9	0	9	15
08:00 AM	7	5	12	0	2	2	7	1	8	22
Total Volume	11	12	23	4	4	8	28	2	30	61
% App. Total	47.8	52.2		50	50		93.3	6.7		
PHF	.393	.600	.479	.250	.500	.500	.778	.500	.833	.693

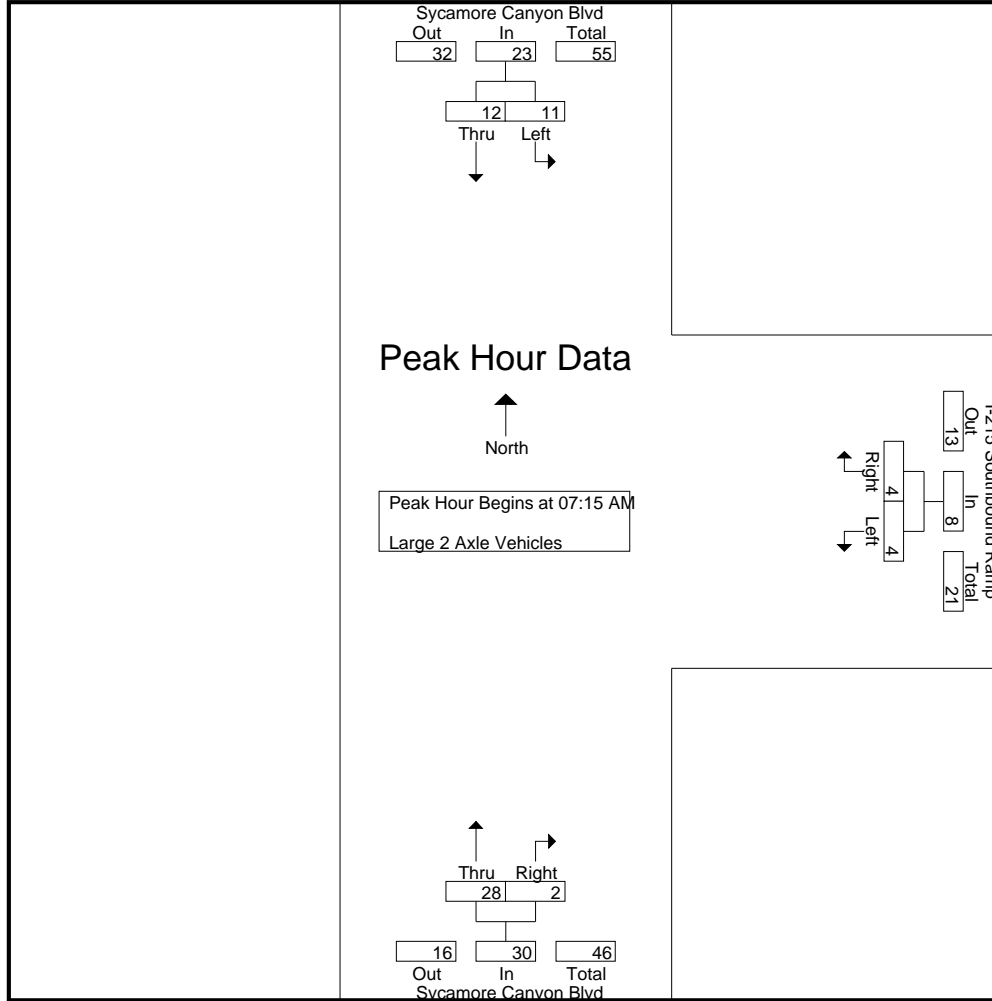

Peak Hour Analysis From 07:15 AM to 08:00 AM - Peak 1 of 1
 Peak Hour for Each Approach Begins at:

	07:15 AM			07:15 AM			07:15 AM		
+0 mins.	2	3	5	0	2	2	8	0	8
+15 mins.	1	3	4	0	0	0	4	1	5
+30 mins.	1	1	2	4	0	4	9	0	9
+45 mins.	7	5	12	0	2	2	7	1	8
Total Volume	11	12	23	4	4	8	28	2	30
% App. Total	47.8	52.2		50	50		93.3	6.7	
PHF	.393	.600	.479	.250	.500	.500	.778	.500	.833

Counts Unlimited Inc
PO Box 1178
Corona, CA 92878
(951) 268-6268

City of Riverside
 N/S: Sycamore Canyon Blvd
 E/W: I-215 Southbound Ramp
 Weather: Clear

File Name : RIV215SSCAM
 Site Code : 06715392
 Start Date : 7/7/2015
 Page No : 1

Groups Printed- 3 Axle Vehicles

Start Time	Sycamore Canyon Blvd Southbound			I-215 Southbound Ramp Westbound			Sycamore Canyon Blvd Northbound			Int. Total
	Left	Thru	App. Total	Left	Right	App. Total	Thru	Right	App. Total	
07:00 AM	0	1	1	0	0	0	1	0	1	2
07:15 AM	0	1	1	1	0	1	3	0	3	5
07:30 AM	0	0	0	2	1	3	1	0	1	4
07:45 AM	0	0	0	0	0	0	3	0	3	3
Total	0	2	2	3	1	4	8	0	8	14
08:00 AM	0	0	0	0	0	0	3	0	3	3
08:15 AM	1	0	1	0	0	0	0	0	0	1
08:30 AM	0	0	0	0	0	0	3	0	3	3
08:45 AM	0	0	0	0	0	0	0	0	0	0
Total	1	0	1	0	0	0	6	0	6	7
Grand Total	1	2	3	3	1	4	14	0	14	21
Apprch %	33.3	66.7		75	25		100	0		
Total %	4.8	9.5	14.3	14.3	4.8	19	66.7	0	66.7	

Start Time	Sycamore Canyon Blvd Southbound			I-215 Southbound Ramp Westbound			Sycamore Canyon Blvd Northbound			Int. Total
	Left	Thru	App. Total	Left	Right	App. Total	Thru	Right	App. Total	
07:15 AM	0	1	1	1	0	1	3	0	3	5
07:30 AM	0	0	0	2	1	3	1	0	1	4
07:45 AM	0	0	0	0	0	0	3	0	3	3
08:00 AM	0	0	0	0	0	0	3	0	3	3
Total Volume	0	1	1	3	1	4	10	0	10	15
% App. Total	0	100		75	25		100	0		
PHF	.000	.250	.250	.375	.250	.333	.833	.000	.833	.750

Peak Hour Analysis From 07:15 AM to 08:00 AM - Peak 1 of 1
 Peak Hour for Entire Intersection Begins at 07:15 AM

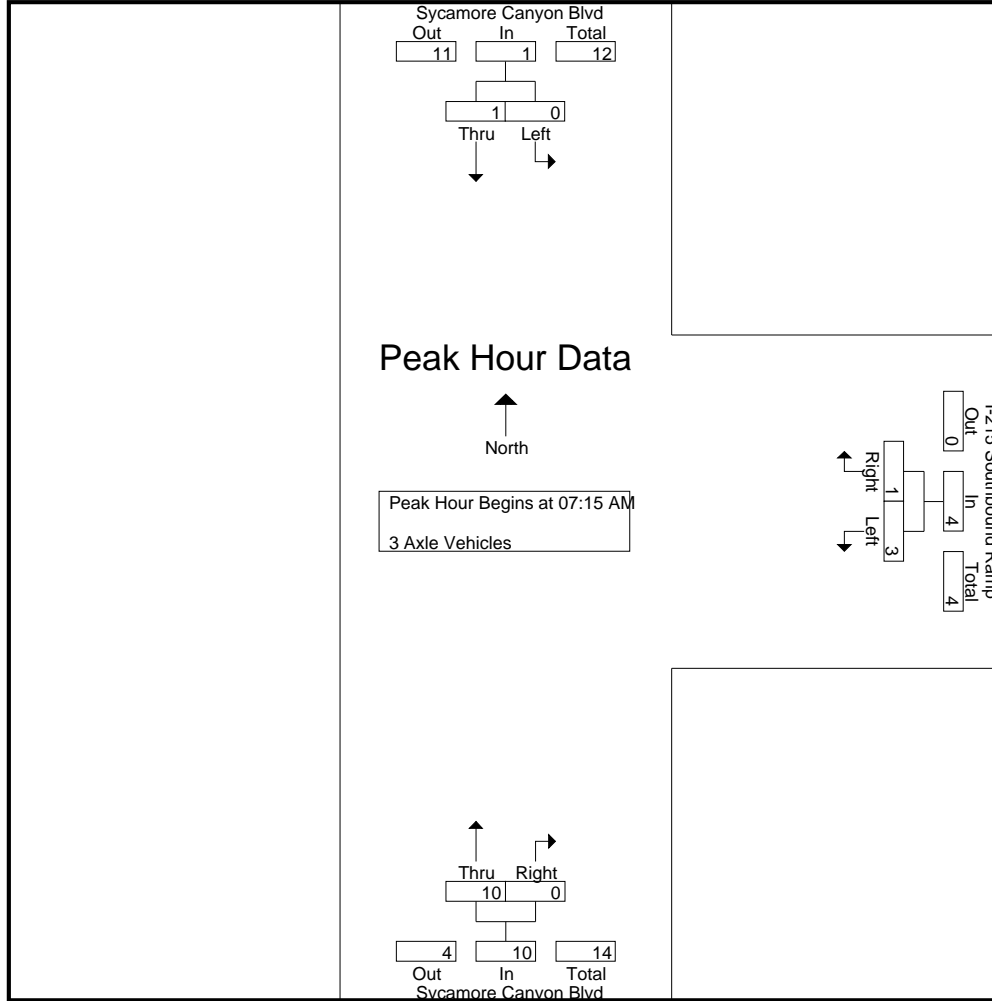

Peak Hour Analysis From 07:15 AM to 08:00 AM - Peak 1 of 1
 Peak Hour for Each Approach Begins at:

	07:15 AM			07:15 AM			07:15 AM		
+0 mins.	0	1	1	1	0	1	3	0	3
+15 mins.	0	0	0	2	1	3	1	0	1
+30 mins.	0	0	0	0	0	0	3	0	3
+45 mins.	0	0	0	0	0	0	3	0	3
Total Volume	0	1	1	3	1	4	10	0	10
% App. Total	0	100		75	25		100	0	
PHF	.000	.250	.250	.375	.250	.333	.833	.000	.833

Counts Unlimited Inc
PO Box 1178
Corona, CA 92878
(951) 268-6268

City of Riverside
 N/S: Sycamore Canyon Blvd
 E/W: I-215 Southbound Ramp
 Weather: Clear

File Name : RIV215SSCAM
 Site Code : 06715392
 Start Date : 7/7/2015
 Page No : 1

Groups Printed- 4+ Axle Trucks

Start Time	Sycamore Canyon Blvd Southbound			I-215 Southbound Ramp Westbound			Sycamore Canyon Blvd Northbound			Int. Total
	Left	Thru	App. Total	Left	Right	App. Total	Thru	Right	App. Total	
07:00 AM	0	0	0	2	0	2	11	1	12	14
07:15 AM	0	0	0	6	0	6	10	0	10	16
07:30 AM	0	0	0	3	0	3	17	1	18	21
07:45 AM	0	0	0	2	0	2	11	0	11	13
Total	0	0	0	13	0	13	49	2	51	64
08:00 AM	0	0	0	1	0	1	13	0	13	14
08:15 AM	0	0	0	1	0	1	14	1	15	16
08:30 AM	0	0	0	1	1	2	7	0	7	9
08:45 AM	0	0	0	3	0	3	1	0	1	4
Total	0	0	0	6	1	7	35	1	36	43
Grand Total	0	0	0	19	1	20	84	3	87	107
Apprch %	0	0		95	5		96.6	3.4		
Total %	0	0		17.8	0.9	18.7	78.5	2.8	81.3	

Start Time	Sycamore Canyon Blvd Southbound			I-215 Southbound Ramp Westbound			Sycamore Canyon Blvd Northbound			Int. Total
	Left	Thru	App. Total	Left	Right	App. Total	Thru	Right	App. Total	
Peak Hour Analysis From 07:15 AM to 08:00 AM - Peak 1 of 1										
Peak Hour for Entire Intersection Begins at 07:15 AM										
07:15 AM	0	0	0	6	0	6	10	0	10	16
07:30 AM	0	0	0	3	0	3	17	1	18	21
07:45 AM	0	0	0	2	0	2	11	0	11	13
08:00 AM	0	0	0	1	0	1	13	0	13	14
Total Volume	0	0	0	12	0	12	51	1	52	64
% App. Total	0	0		100	0		98.1	1.9		
PHF	.000	.000	.000	.500	.000	.500	.750	.250	.722	.762

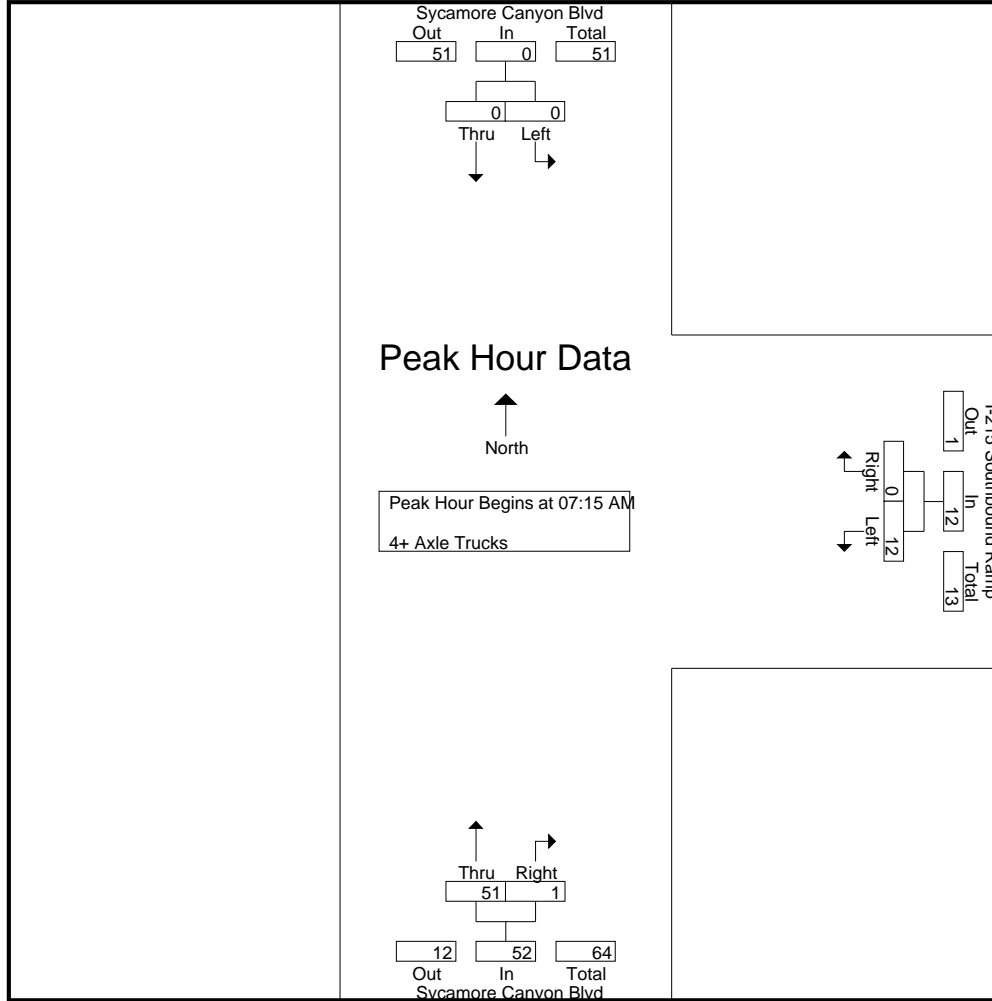

Peak Hour Analysis From 07:15 AM to 08:00 AM - Peak 1 of 1
 Peak Hour for Each Approach Begins at:

	07:15 AM			07:15 AM			07:15 AM		
+0 mins.	0	0	0	6	0	6	10	0	10
+15 mins.	0	0	0	3	0	3	17	1	18
+30 mins.	0	0	0	2	0	2	11	0	11
+45 mins.	0	0	0	1	0	1	13	0	13
Total Volume	0	0	0	12	0	12	51	1	52
% App. Total	0	0	0	100	0		98.1	1.9	
PHF	.000	.000	.000	.500	.000	.500	.750	.250	.722

Counts Unlimited Inc
 PO Box 1178
 Corona, CA 92878
 (951) 268-6268

City of Riverside
 N/S: Sycamore Canyon Blvd
 E/W: I-215 Southbound Ramps
 Weather: Clear

File Name : RIV215SSCPM
 Site Code : 06715392
 Start Date : 7/7/2015
 Page No : 1

Groups Printed- Passenger Vehicles - Large 2 Axle Vehicles - 3 Axle Vehicles - 4+ Axle Trucks

Start Time	Sycamore Canyon Blvd Southbound			I-215 S Ramps Westbound			Sycamore Canyon Blvd Northbound			Int. Total
	Left	Thru	App. Total	Left	Right	App. Total	Thru	Right	App. Total	
04:00 PM	18	92	110	28	48	76	172	31	203	389
04:15 PM	38	63	101	25	44	69	125	23	148	318
04:30 PM	36	75	111	27	58	85	179	22	201	397
04:45 PM	38	89	127	26	57	83	132	25	157	367
Total	130	319	449	106	207	313	608	101	709	1471
05:00 PM	30	86	116	21	33	54	213	48	261	431
05:15 PM	38	91	129	36	63	99	139	33	172	400
05:30 PM	42	76	118	22	60	82	103	18	121	321
05:45 PM	42	71	113	23	56	79	106	12	118	310
Total	152	324	476	102	212	314	561	111	672	1462
Grand Total	282	643	925	208	419	627	1169	212	1381	2933
Apprch %	30.5	69.5		33.2	66.8		84.6	15.4		
Total %	9.6	21.9	31.5	7.1	14.3	21.4	39.9	7.2	47.1	
Passenger Vehicles	276	633	909	170	411	581	1110	206	1316	2806
% Passenger Vehicles	97.9	98.4	98.3	81.7	98.1	92.7	95	97.2	95.3	95.7
Large 2 Axle Vehicles	6	10	16	7	8	15	17	2	19	50
% Large 2 Axle Vehicles	2.1	1.6	1.7	3.4	1.9	2.4	1.5	0.9	1.4	1.7
3 Axle Vehicles	0	0	0	9	0	9	7	1	8	17
% 3 Axle Vehicles	0	0	0	4.3	0	1.4	0.6	0.5	0.6	0.6
4+ Axle Trucks	0	0	0	22	0	22	35	3	38	60
% 4+ Axle Trucks	0	0	0	10.6	0	3.5	3	1.4	2.8	2

Start Time	Sycamore Canyon Blvd Southbound			I-215 S Ramps Westbound			Sycamore Canyon Blvd Northbound			Int. Total
	Left	Thru	App. Total	Left	Right	App. Total	Thru	Right	App. Total	
Peak Hour Analysis From 04:00 PM to 05:45 PM - Peak 1 of 1										
Peak Hour for Entire Intersection Begins at 04:30 PM										
04:30 PM	36	75	111	27	58	85	179	22	201	397
04:45 PM	38	89	127	26	57	83	132	25	157	367
05:00 PM	30	86	116	21	33	54	213	48	261	431
05:15 PM	38	91	129	36	63	99	139	33	172	400
Total Volume	142	341	483	110	211	321	663	128	791	1595
% App. Total	29.4	70.6		34.3	65.7		83.8	16.2		
PHF	.934	.937	.936	.764	.837	.811	.778	.667	.758	.925

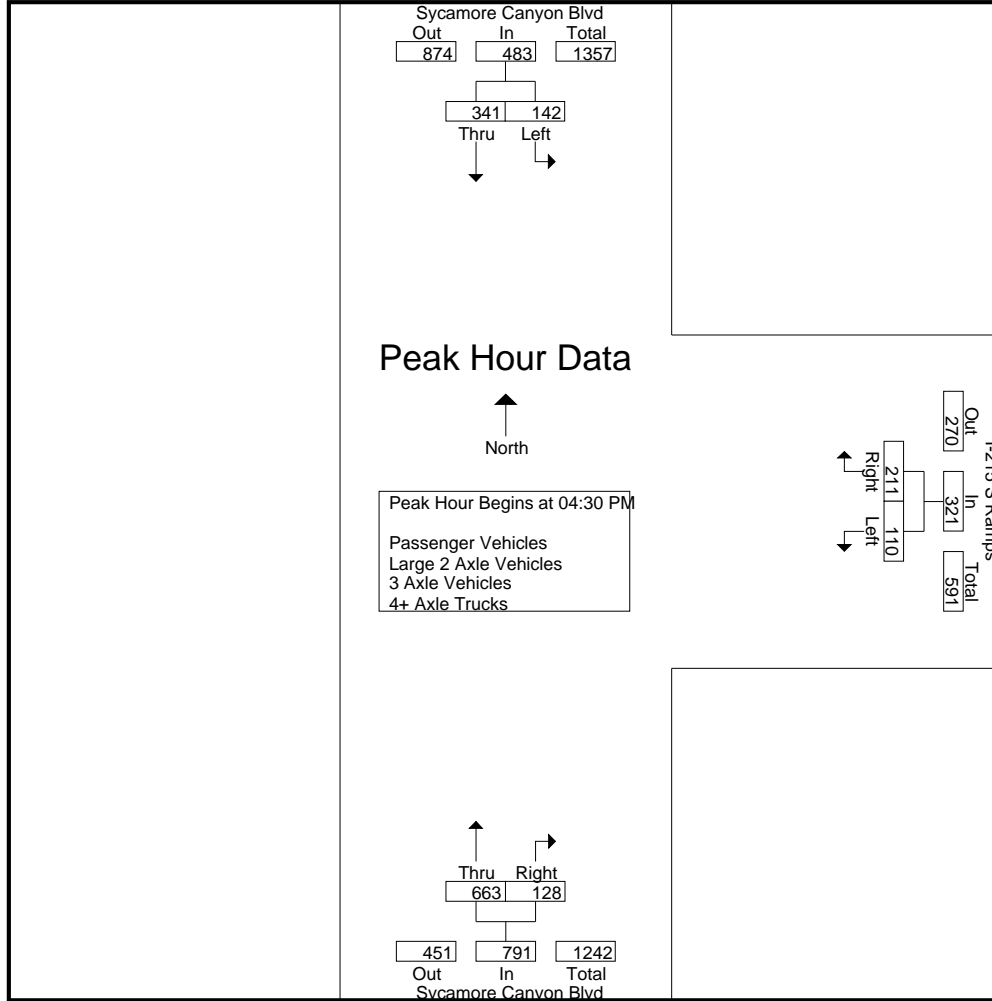

Peak Hour Analysis From 04:00 PM to 05:45 PM - Peak 1 of 1
 Peak Hour for Each Approach Begins at:

	04:45 PM			04:30 PM			04:30 PM		
+0 mins.	38	89	127	27	58	85	179	22	201
+15 mins.	30	86	116	26	57	83	132	25	157
+30 mins.	38	91	129	21	33	54	213	48	261
+45 mins.	42	76	118	36	63	99	139	33	172
Total Volume	148	342	490	110	211	321	663	128	791
% App. Total	30.2	69.8		34.3	65.7		83.8	16.2	
PHF	.881	.940	.950	.764	.837	.811	.778	.667	.758

Counts Unlimited Inc
 PO Box 1178
 Corona, CA 92878
 (951) 268-6268

City of Riverside
 N/S: Sycamore Canyon Blvd
 EW: I-215 Southbound Ramps
 Weather: Clear

File Name : RIV215SSCPM
 Site Code : 06715392
 Start Date : 7/7/2015
 Page No : 1

Groups Printed- Passenger Vehicles

Start Time	Sycamore Canyon Blvd Southbound			I-215 S Ramps Westbound			Sycamore Canyon Blvd Northbound			Int. Total
	Left	Thru	App. Total	Left	Right	App. Total	Thru	Right	App. Total	
04:00 PM	18	91	109	20	45	65	161	30	191	365
04:15 PM	36	62	98	22	44	66	118	23	141	305
04:30 PM	36	73	109	21	57	78	175	22	197	384
04:45 PM	35	89	124	24	56	80	122	25	147	351
Total	125	315	440	87	202	289	576	100	676	1405
05:00 PM	30	84	114	15	32	47	205	47	252	413
05:15 PM	38	89	127	30	61	91	131	31	162	380
05:30 PM	41	76	117	18	60	78	98	18	116	311
05:45 PM	42	69	111	20	56	76	100	10	110	297
Total	151	318	469	83	209	292	534	106	640	1401
Grand Total	276	633	909	170	411	581	1110	206	1316	2806
Apprch %	30.4	69.6		29.3	70.7		84.3	15.7		
Total %	9.8	22.6	32.4	6.1	14.6	20.7	39.6	7.3	46.9	

Start Time	Sycamore Canyon Blvd Southbound			I-215 S Ramps Westbound			Sycamore Canyon Blvd Northbound			Int. Total
	Left	Thru	App. Total	Left	Right	App. Total	Thru	Right	App. Total	
04:30 PM	36	73	109	21	57	78	175	22	197	384
04:45 PM	35	89	124	24	56	80	122	25	147	351
05:00 PM	30	84	114	15	32	47	205	47	252	413
05:15 PM	38	89	127	30	61	91	131	31	162	380
Total Volume	139	335	474	90	206	296	633	125	758	1528
% App. Total	29.3	70.7		30.4	69.6		83.5	16.5		
PHF	.914	.941	.933	.750	.844	.813	.772	.665	.752	.925

Peak Hour Analysis From 04:30 PM to 05:15 PM - Peak 1 of 1
 Peak Hour for Entire Intersection Begins at 04:30 PM

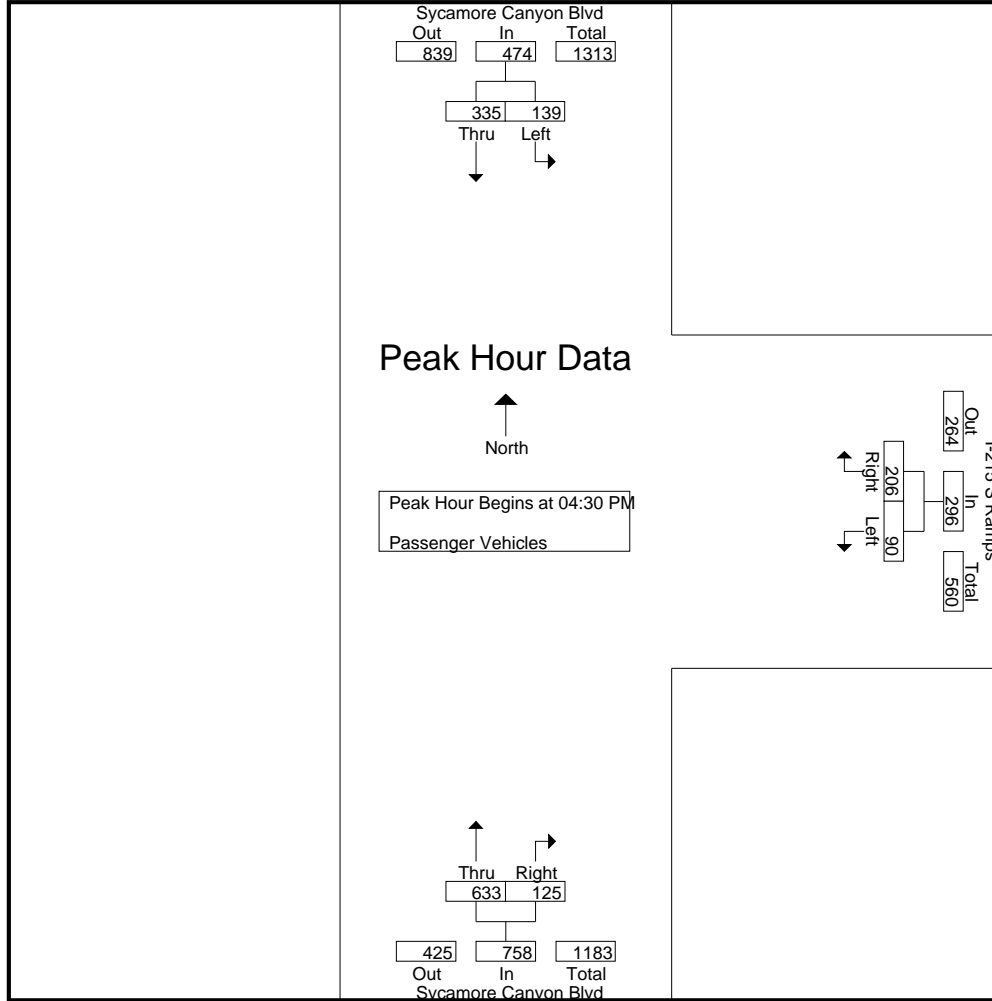

Peak Hour Analysis From 04:30 PM to 05:15 PM - Peak 1 of 1
 Peak Hour for Each Approach Begins at:

	04:30 PM			04:30 PM			04:30 PM		
+0 mins.	36	73	109	21	57	78	175	22	197
+15 mins.	35	89	124	24	56	80	122	25	147
+30 mins.	30	84	114	15	32	47	205	47	252
+45 mins.	38	89	127	30	61	91	131	31	162
Total Volume	139	335	474	90	206	296	633	125	758
% App. Total	29.3	70.7		30.4	69.6		83.5	16.5	
PHF	.914	.941	.933	.750	.844	.813	.772	.665	.752

Counts Unlimited Inc
 PO Box 1178
 Corona, CA 92878
 (951) 268-6268

City of Riverside
 N/S: Sycamore Canyon Blvd
 EW: I-215 Southbound Ramps
 Weather: Clear

File Name : RIV215SSCPM
 Site Code : 06715392
 Start Date : 7/7/2015
 Page No : 1

Groups Printed- Large 2 Axle Vehicles

Start Time	Sycamore Canyon Blvd Southbound			I-215 S Ramps Westbound			Sycamore Canyon Blvd Northbound			Int. Total
	Left	Thru	App. Total	Left	Right	App. Total	Thru	Right	App. Total	
04:00 PM	0	1	1	1	3	4	4	1	5	10
04:15 PM	2	1	3	0	0	0	0	0	0	3
04:30 PM	0	2	2	2	1	3	1	0	1	6
04:45 PM	3	0	3	0	1	1	5	0	5	9
Total	5	4	9	3	5	8	10	1	11	28
05:00 PM	0	2	2	1	1	2	2	1	3	7
05:15 PM	0	2	2	1	2	3	2	0	2	7
05:30 PM	1	0	1	1	0	1	1	0	1	3
05:45 PM	0	2	2	1	0	1	2	0	2	5
Total	1	6	7	4	3	7	7	1	8	22
Grand Total	6	10	16	7	8	15	17	2	19	50
Apprch %	37.5	62.5		46.7	53.3		89.5	10.5		
Total %	12	20	32	14	16	30	34	4	38	

Start Time	Sycamore Canyon Blvd Southbound			I-215 S Ramps Westbound			Sycamore Canyon Blvd Northbound			Int. Total
	Left	Thru	App. Total	Left	Right	App. Total	Thru	Right	App. Total	
04:30 PM	0	2	2	2	1	3	1	0	1	6
04:45 PM	3	0	3	0	1	1	5	0	5	9
05:00 PM	0	2	2	1	1	2	2	1	3	7
05:15 PM	0	2	2	1	2	3	2	0	2	7
Total Volume	3	6	9	4	5	9	10	1	11	29
% App. Total	33.3	66.7		44.4	55.6		90.9	9.1		
PHF	.250	.750	.750	.500	.625	.750	.500	.250	.550	.806

Peak Hour Analysis From 04:30 PM to 05:15 PM - Peak 1 of 1
 Peak Hour for Entire Intersection Begins at 04:30 PM

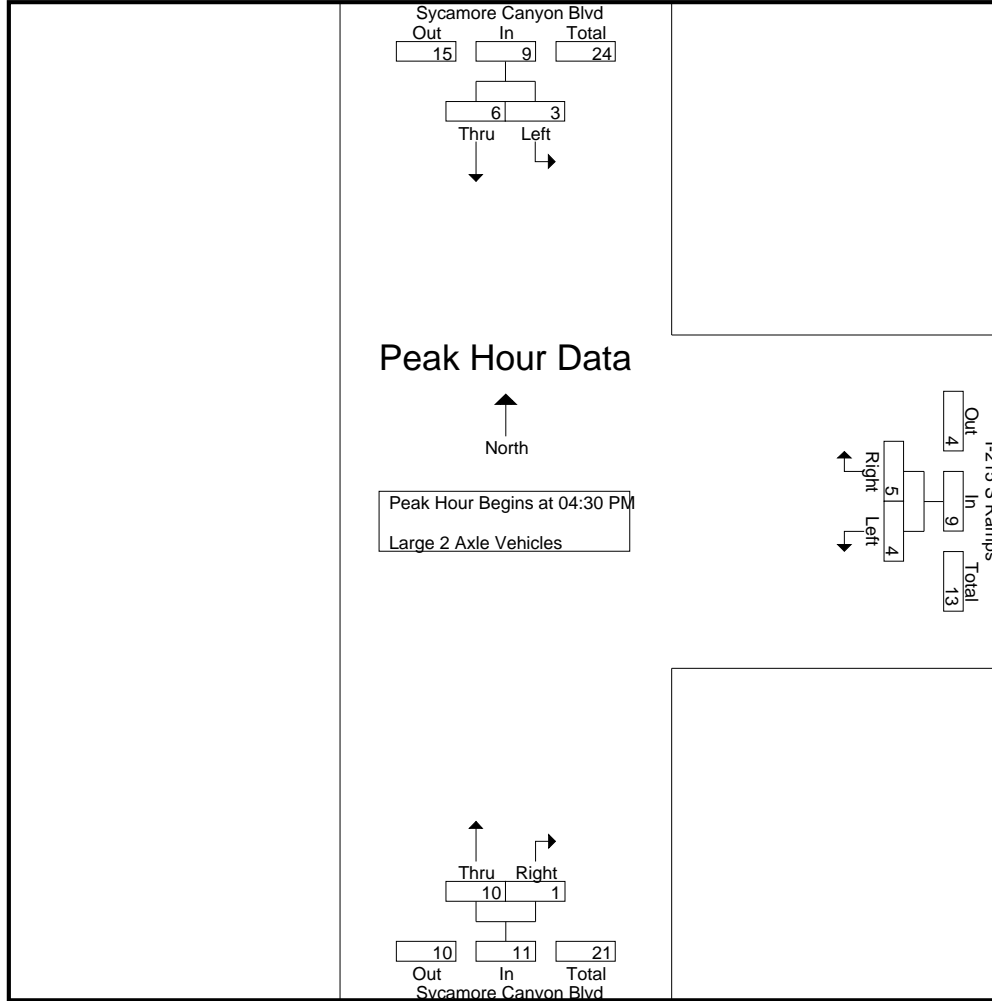

Peak Hour Analysis From 04:30 PM to 05:15 PM - Peak 1 of 1
 Peak Hour for Each Approach Begins at:

	04:30 PM			04:30 PM			04:30 PM		
+0 mins.	0	2	2	2	1	3	1	0	1
+15 mins.	3	0	3	0	1	1	5	0	5
+30 mins.	0	2	2	1	1	2	2	1	3
+45 mins.	0	2	2	1	2	3	2	0	2
Total Volume	3	6	9	4	5	9	10	1	11
% App. Total	33.3	66.7		44.4	55.6		90.9	9.1	
PHF	.250	.750	.750	.500	.625	.750	.500	.250	.550

Counts Unlimited Inc
 PO Box 1178
 Corona, CA 92878
 (951) 268-6268

City of Riverside
 N/S: Sycamore Canyon Blvd
 EW: I-215 Southbound Ramps
 Weather: Clear

File Name : RIV215SSCPM
 Site Code : 06715392
 Start Date : 7/7/2015
 Page No : 1

Groups Printed- 3 Axle Vehicles

Start Time	Sycamore Canyon Blvd Southbound			I-215 S Ramps Westbound			Sycamore Canyon Blvd Northbound			Int. Total
	Left	Thru	App. Total	Left	Right	App. Total	Thru	Right	App. Total	
04:00 PM	0	0	0	2	0	2	1	0	1	3
04:15 PM	0	0	0	0	0	0	2	0	2	2
04:30 PM	0	0	0	3	0	3	0	0	0	3
04:45 PM	0	0	0	1	0	1	0	0	0	1
Total	0	0	0	6	0	6	3	0	3	9
05:00 PM	0	0	0	2	0	2	1	0	1	3
05:15 PM	0	0	0	1	0	1	1	0	1	2
05:30 PM	0	0	0	0	0	0	1	0	1	1
05:45 PM	0	0	0	0	0	0	1	1	2	2
Total	0	0	0	3	0	3	4	1	5	8
Grand Total	0	0	0	9	0	9	7	1	8	17
Apprch %	0	0		100	0		87.5	12.5		
Total %	0	0		52.9	0	52.9	41.2	5.9	47.1	

Start Time	Sycamore Canyon Blvd Southbound			I-215 S Ramps Westbound			Sycamore Canyon Blvd Northbound			Int. Total
	Left	Thru	App. Total	Left	Right	App. Total	Thru	Right	App. Total	
04:30 PM	0	0	0	3	0	3	0	0	0	3
04:45 PM	0	0	0	1	0	1	0	0	0	1
05:00 PM	0	0	0	2	0	2	1	0	1	3
05:15 PM	0	0	0	1	0	1	1	0	1	2
Total Volume	0	0	0	7	0	7	2	0	2	9
% App. Total	0	0		100	0		100	0		
PHF	.000	.000	.000	.583	.000	.583	.500	.000	.500	.750

Peak Hour Analysis From 04:30 PM to 05:15 PM - Peak 1 of 1
 Peak Hour for Entire Intersection Begins at 04:30 PM

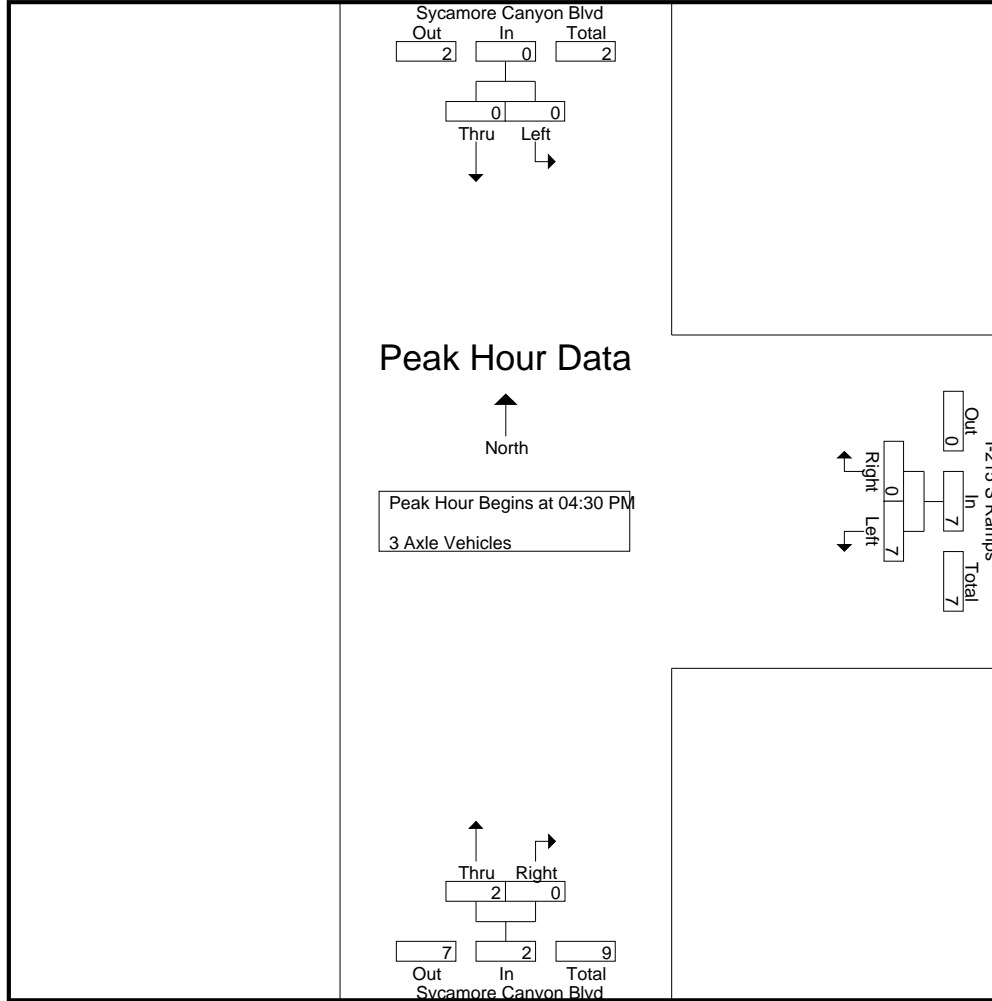

Peak Hour Analysis From 04:30 PM to 05:15 PM - Peak 1 of 1
 Peak Hour for Each Approach Begins at:

	04:30 PM			04:30 PM			04:30 PM		
+0 mins.	0	0	0	3	0	3	0	0	0
+15 mins.	0	0	0	1	0	1	0	0	0
+30 mins.	0	0	0	2	0	2	1	0	1
+45 mins.	0	0	0	1	0	1	1	0	1
Total Volume	0	0	0	7	0	7	2	0	2
% App. Total	0	0	0	100	0	100	100	0	100
PHF	.000	.000	.000	.583	.000	.583	.500	.000	.500

Counts Unlimited Inc
 PO Box 1178
 Corona, CA 92878
 (951) 268-6268

City of Riverside
 N/S: Sycamore Canyon Blvd
 EW: I-215 Southbound Ramps
 Weather: Clear

File Name : RIV215SSCPM
 Site Code : 06715392
 Start Date : 7/7/2015
 Page No : 1

Groups Printed- 4+ Axle Trucks

Start Time	Sycamore Canyon Blvd Southbound			I-215 S Ramps Westbound			Sycamore Canyon Blvd Northbound			Int. Total
	Left	Thru	App. Total	Left	Right	App. Total	Thru	Right	App. Total	
04:00 PM	0	0	0	5	0	5	6	0	6	11
04:15 PM	0	0	0	3	0	3	5	0	5	8
04:30 PM	0	0	0	1	0	1	3	0	3	4
04:45 PM	0	0	0	1	0	1	5	0	5	6
Total	0	0	0	10	0	10	19	0	19	29
05:00 PM	0	0	0	3	0	3	5	0	5	8
05:15 PM	0	0	0	4	0	4	5	2	7	11
05:30 PM	0	0	0	3	0	3	3	0	3	6
05:45 PM	0	0	0	2	0	2	3	1	4	6
Total	0	0	0	12	0	12	16	3	19	31
Grand Total	0	0	0	22	0	22	35	3	38	60
Apprch %	0	0		100	0		92.1	7.9		
Total %	0	0		36.7	0	36.7	58.3	5	63.3	

Start Time	Sycamore Canyon Blvd Southbound			I-215 S Ramps Westbound			Sycamore Canyon Blvd Northbound			Int. Total
	Left	Thru	App. Total	Left	Right	App. Total	Thru	Right	App. Total	
04:30 PM	0	0	0	1	0	1	3	0	3	4
04:45 PM	0	0	0	1	0	1	5	0	5	6
05:00 PM	0	0	0	3	0	3	5	0	5	8
05:15 PM	0	0	0	4	0	4	5	2	7	11
Total Volume	0	0	0	9	0	9	18	2	20	29
% App. Total	0	0		100	0		90	10		
PHF	.000	.000	.000	.563	.000	.563	.900	.250	.714	.659

Peak Hour Analysis From 04:30 PM to 05:15 PM - Peak 1 of 1
 Peak Hour for Entire Intersection Begins at 04:30 PM

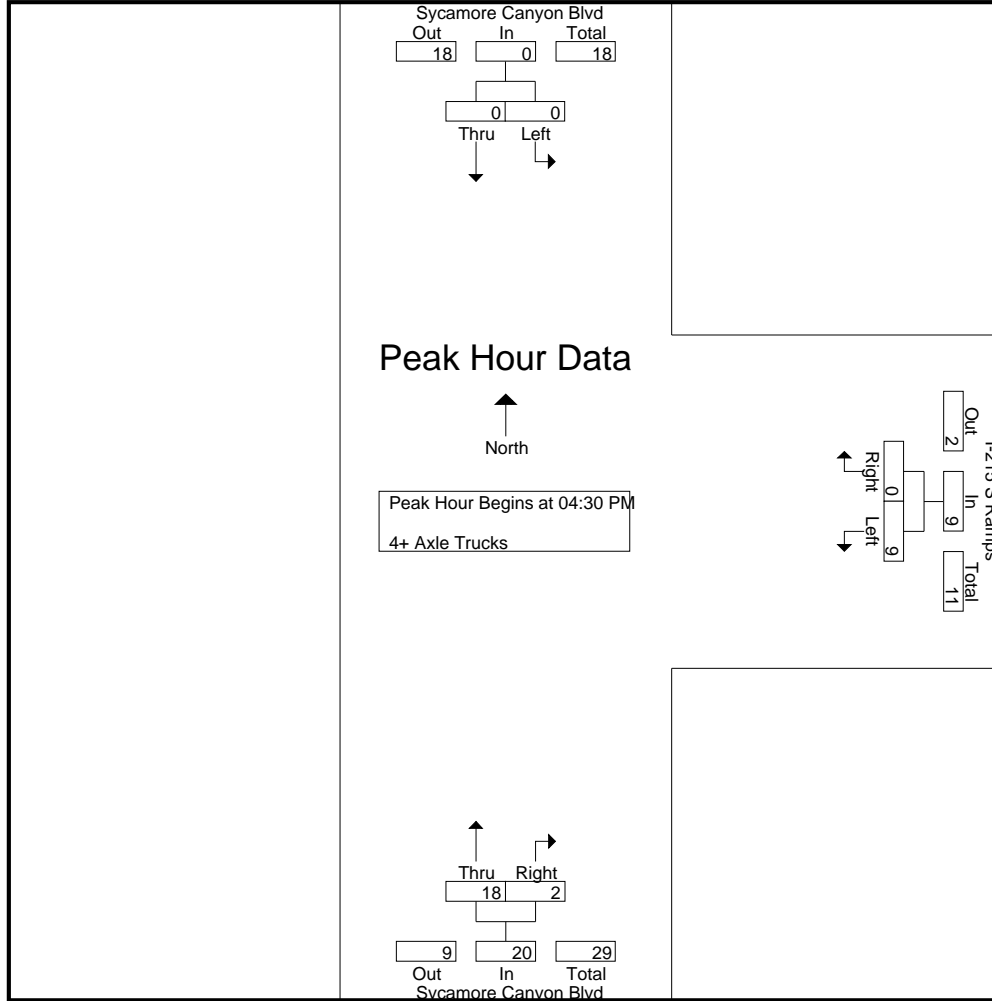

Peak Hour Analysis From 04:30 PM to 05:15 PM - Peak 1 of 1
 Peak Hour for Each Approach Begins at:

	04:30 PM			04:30 PM			04:30 PM		
+0 mins.	0	0	0	1	0	1	3	0	3
+15 mins.	0	0	0	1	0	1	5	0	5
+30 mins.	0	0	0	3	0	3	5	0	5
+45 mins.	0	0	0	4	0	4	5	2	7
Total Volume	0	0	0	9	0	9	18	2	20
% App. Total	0	0	0	100	0	100	90	10	100
PHF	.000	.000	.000	.563	.000	.563	.900	.250	.714

City of Riverside
 N/S: Sycamore Canyon Blvd
 E/W: Dan Kipper Road
 Weather: Clear

File Name : RIVSCDKAM
 Site Code : 06715392
 Start Date : 7/7/2015
 Page No : 1

Groups Printed- Passenger Vehicles - Large 2 Axle Vehicles - 3 Axle Vehicles - 4+ Axle Trucks

Start Time	Sycamore Canyon Blvd Southbound			Sycamore Canyon Blvd Northbound			Dan Kipper Road Eastbound			Int. Total
	Thru	Right	App. Total	Left	Thru	App. Total	Left	Right	App. Total	
07:00 AM	81	7	88	1	300	301	0	1	1	390
07:15 AM	101	17	118	3	337	340	0	0	0	458
07:30 AM	119	6	125	1	370	371	0	1	1	497
07:45 AM	144	5	149	3	316	319	0	0	0	468
Total	445	35	480	8	1323	1331	0	2	2	1813
08:00 AM	93	3	96	4	279	283	0	1	1	380
08:15 AM	66	4	70	0	233	233	0	0	0	303
08:30 AM	77	2	79	4	234	238	0	0	0	317
08:45 AM	82	12	94	0	148	148	0	0	0	242
Total	318	21	339	8	894	902	0	1	1	1242
Grand Total	763	56	819	16	2217	2233	0	3	3	3055
Apprch %	93.2	6.8		0.7	99.3		0	100		
Total %	25	1.8	26.8	0.5	72.6	73.1	0	0.1	0.1	
Passenger Vehicles	710	56	766	14	2058	2072	0	3	3	2841
% Passenger Vehicles	93.1	100	93.5	87.5	92.8	92.8	0	100	100	93
Large 2 Axle Vehicles	18	0	18	1	57	58	0	0	0	76
% Large 2 Axle Vehicles	2.4	0	2.2	6.2	2.6	2.6	0	0	0	2.5
3 Axle Vehicles	6	0	6	1	11	12	0	0	0	18
% 3 Axle Vehicles	0.8	0	0.7	6.2	0.5	0.5	0	0	0	0.6
4+ Axle Trucks	29	0	29	0	91	91	0	0	0	120
% 4+ Axle Trucks	3.8	0	3.5	0	4.1	4.1	0	0	0	3.9

Start Time	Sycamore Canyon Blvd Southbound			Sycamore Canyon Blvd Northbound			Dan Kipper Road Eastbound			Int. Total
	Thru	Right	App. Total	Left	Thru	App. Total	Left	Right	App. Total	
Peak Hour Analysis From 07:00 AM to 08:45 AM - Peak 1 of 1										
Peak Hour for Entire Intersection Begins at 07:00 AM										
07:00 AM	81	7	88	1	300	301	0	1	1	390
07:15 AM	101	17	118	3	337	340	0	0	0	458
07:30 AM	119	6	125	1	370	371	0	1	1	497
07:45 AM	144	5	149	3	316	319	0	0	0	468
Total Volume	445	35	480	8	1323	1331	0	2	2	1813
% App. Total	92.7	7.3		0.6	99.4		0	100		
PHF	.773	.515	.805	.667	.894	.897	.000	.500	.500	.912

City of Riverside
 N/S: Sycamore Canyon Blvd
 E/W: Dan Kipper Road
 Weather: Clear

File Name : RIVSCDKAM
 Site Code : 06715392
 Start Date : 7/7/2015
 Page No : 2

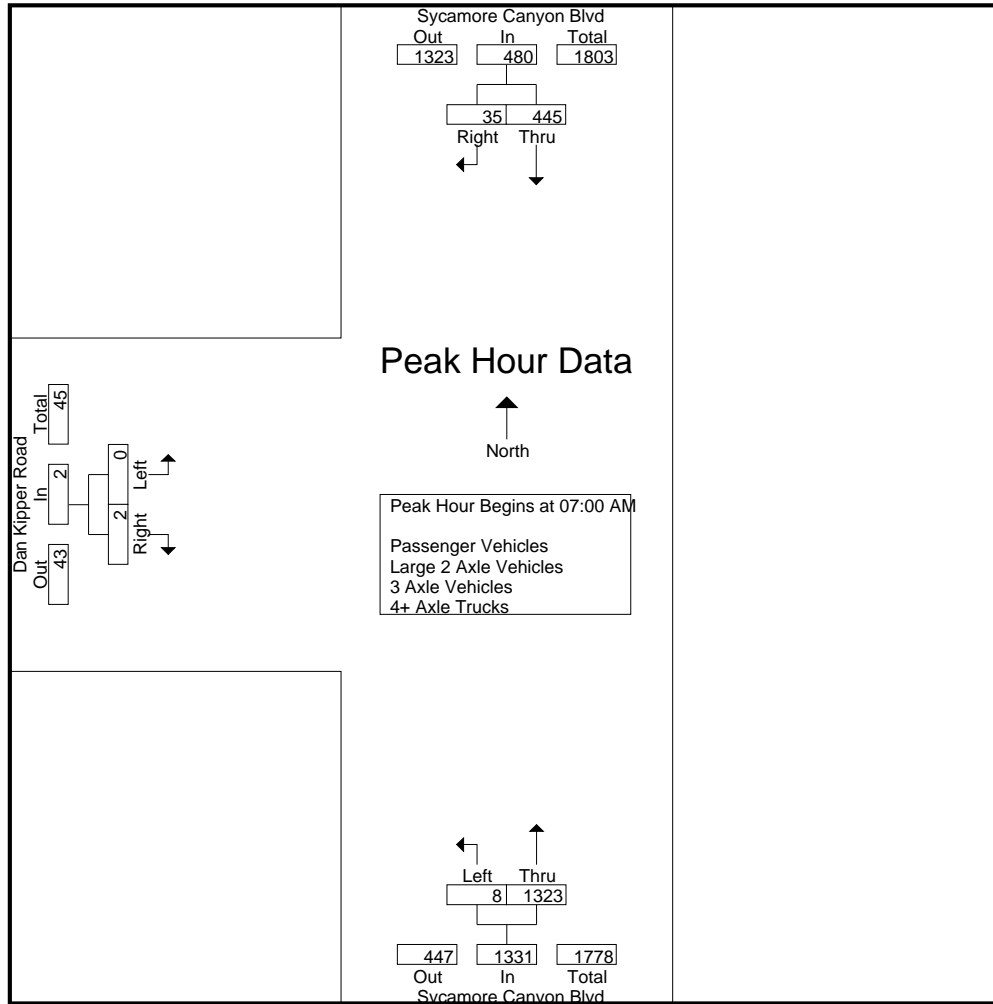

Peak Hour Analysis From 07:00 AM to 08:45 AM - Peak 1 of 1
 Peak Hour for Each Approach Begins at:

	07:15 AM			07:00 AM			07:00 AM		
+0 mins.	101	17	118	1	300	301	0	1	1
+15 mins.	119	6	125	3	337	340	0	0	0
+30 mins.	144	5	149	1	370	371	0	1	1
+45 mins.	93	3	96	3	316	319	0	0	0
Total Volume	457	31	488	8	1323	1331	0	2	2
% App. Total	93.6	6.4		0.6	99.4		0	100	
PHF	.793	.456	.819	.667	.894	.897	.000	.500	.500

City of Riverside
 N/S: Sycamore Canyon Blvd
 E/W: Dan Kipper Road
 Weather: Clear

File Name : RIVSCDKAM
 Site Code : 06715392
 Start Date : 7/7/2015
 Page No : 1

Groups Printed- Passenger Vehicles

Start Time	Sycamore Canyon Blvd Southbound			Sycamore Canyon Blvd Northbound			Dan Kipper Road Eastbound			Int. Total
	Thru	Right	App. Total	Left	Thru	App. Total	Left	Right	App. Total	
07:00 AM	78	7	85	1	291	292	0	1	1	378
07:15 AM	95	17	112	3	317	320	0	0	0	432
07:30 AM	108	6	114	1	346	347	0	1	1	462
07:45 AM	138	5	143	3	293	296	0	0	0	439
Total	419	35	454	8	1247	1255	0	2	2	1711
08:00 AM	86	3	89	3	260	263	0	1	1	353
08:15 AM	56	4	60	0	212	212	0	0	0	272
08:30 AM	71	2	73	3	211	214	0	0	0	287
08:45 AM	78	12	90	0	128	128	0	0	0	218
Total	291	21	312	6	811	817	0	1	1	1130
Grand Total	710	56	766	14	2058	2072	0	3	3	2841
Apprch %	92.7	7.3		0.7	99.3		0	100		
Total %	25	2	27	0.5	72.4	72.9	0	0.1	0.1	

Start Time	Sycamore Canyon Blvd Southbound			Sycamore Canyon Blvd Northbound			Dan Kipper Road Eastbound			Int. Total
	Thru	Right	App. Total	Left	Thru	App. Total	Left	Right	App. Total	
07:00 AM	78	7	85	1	291	292	0	1	1	378
07:15 AM	95	17	112	3	317	320	0	0	0	432
07:30 AM	108	6	114	1	346	347	0	1	1	462
07:45 AM	138	5	143	3	293	296	0	0	0	439
Total Volume	419	35	454	8	1247	1255	0	2	2	1711
% App. Total	92.3	7.7		0.6	99.4		0	100		
PHF	.759	.515	.794	.667	.901	.904	.000	.500	.500	.926

Peak Hour Analysis From 07:00 AM to 07:45 AM - Peak 1 of 1
 Peak Hour for Entire Intersection Begins at 07:00 AM

City of Riverside
 N/S: Sycamore Canyon Blvd
 E/W: Dan Kipper Road
 Weather: Clear

File Name : RIVSCDKAM
 Site Code : 06715392
 Start Date : 7/7/2015
 Page No : 2

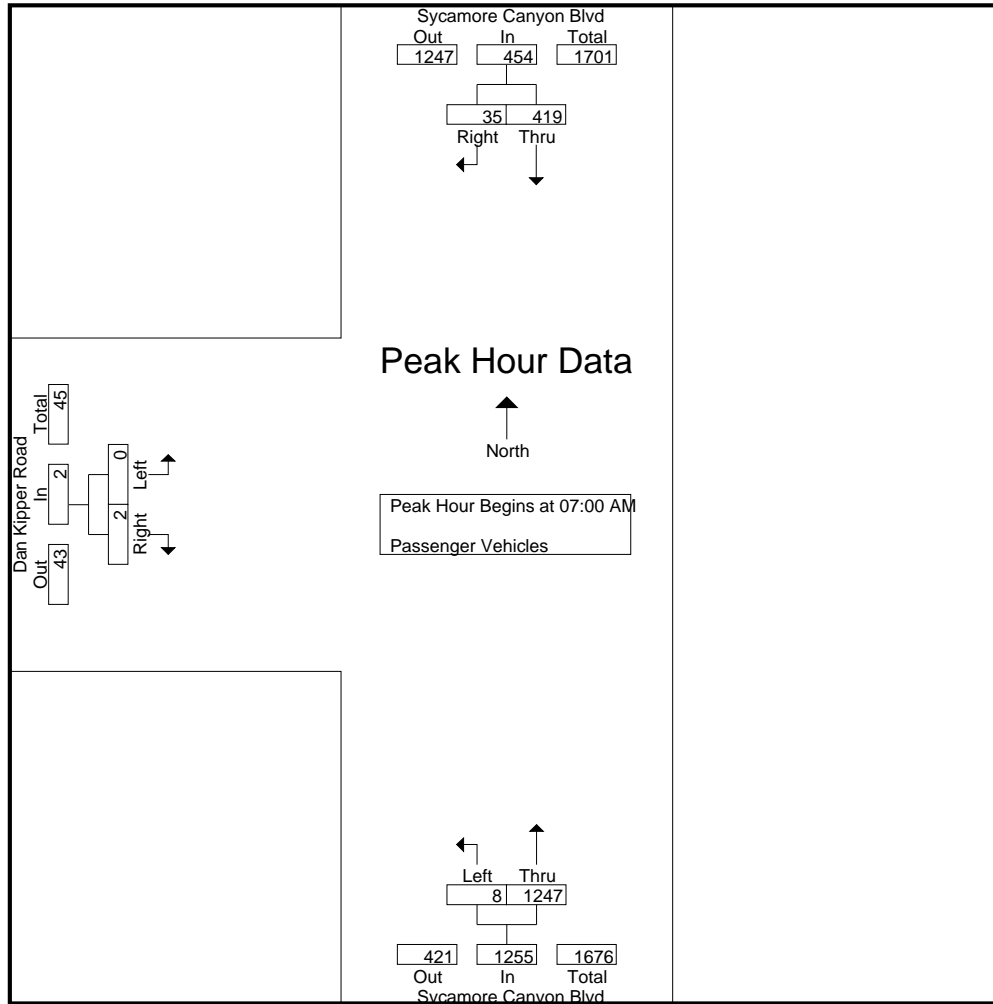

Peak Hour Analysis From 07:00 AM to 07:45 AM - Peak 1 of 1
 Peak Hour for Each Approach Begins at:

	07:00 AM			07:00 AM			07:00 AM		
+0 mins.	78	7	85	1	291	292	0	1	1
+15 mins.	95	17	112	3	317	320	0	0	0
+30 mins.	108	6	114	1	346	347	0	1	1
+45 mins.	138	5	143	3	293	296	0	0	0
Total Volume	419	35	454	8	1247	1255	0	2	2
% App. Total	92.3	7.7		0.6	99.4		0	100	
PHF	.759	.515	.794	.667	.901	.904	.000	.500	.500

City of Riverside
 N/S: Sycamore Canyon Blvd
 E/W: Dan Kipper Road
 Weather: Clear

File Name : RIVSCDKAM
 Site Code : 06715392
 Start Date : 7/7/2015
 Page No : 1

Groups Printed- Large 2 Axle Vehicles

Start Time	Sycamore Canyon Blvd Southbound			Sycamore Canyon Blvd Northbound			Dan Kipper Road Eastbound			Int. Total
	Thru	Right	App. Total	Left	Thru	App. Total	Left	Right	App. Total	
07:00 AM	0	0	0	0	2	2	0	0	0	2
07:15 AM	1	0	1	0	10	10	0	0	0	11
07:30 AM	7	0	7	0	10	10	0	0	0	17
07:45 AM	1	0	1	0	9	9	0	0	0	10
Total	9	0	9	0	31	31	0	0	0	40
08:00 AM	4	0	4	1	5	6	0	0	0	10
08:15 AM	2	0	2	0	8	8	0	0	0	10
08:30 AM	1	0	1	0	6	6	0	0	0	7
08:45 AM	2	0	2	0	7	7	0	0	0	9
Total	9	0	9	1	26	27	0	0	0	36
Grand Total	18	0	18	1	57	58	0	0	0	76
Apprch %	100	0		1.7	98.3		0	0		
Total %	23.7	0	23.7	1.3	75	76.3	0	0	0	

Start Time	Sycamore Canyon Blvd Southbound			Sycamore Canyon Blvd Northbound			Dan Kipper Road Eastbound			Int. Total
	Thru	Right	App. Total	Left	Thru	App. Total	Left	Right	App. Total	
07:00 AM	0	0	0	0	2	2	0	0	0	2
07:15 AM	1	0	1	0	10	10	0	0	0	11
07:30 AM	7	0	7	0	10	10	0	0	0	17
07:45 AM	1	0	1	0	9	9	0	0	0	10
Total Volume	9	0	9	0	31	31	0	0	0	40
% App. Total	100	0		0	100		0	0		
PHF	.321	.000	.321	.000	.775	.775	.000	.000	.000	.588

Peak Hour Analysis From 07:00 AM to 07:45 AM - Peak 1 of 1
 Peak Hour for Entire Intersection Begins at 07:00 AM

City of Riverside
 N/S: Sycamore Canyon Blvd
 E/W: Dan Kipper Road
 Weather: Clear

File Name : RIVSCDKAM
 Site Code : 06715392
 Start Date : 7/7/2015
 Page No : 2

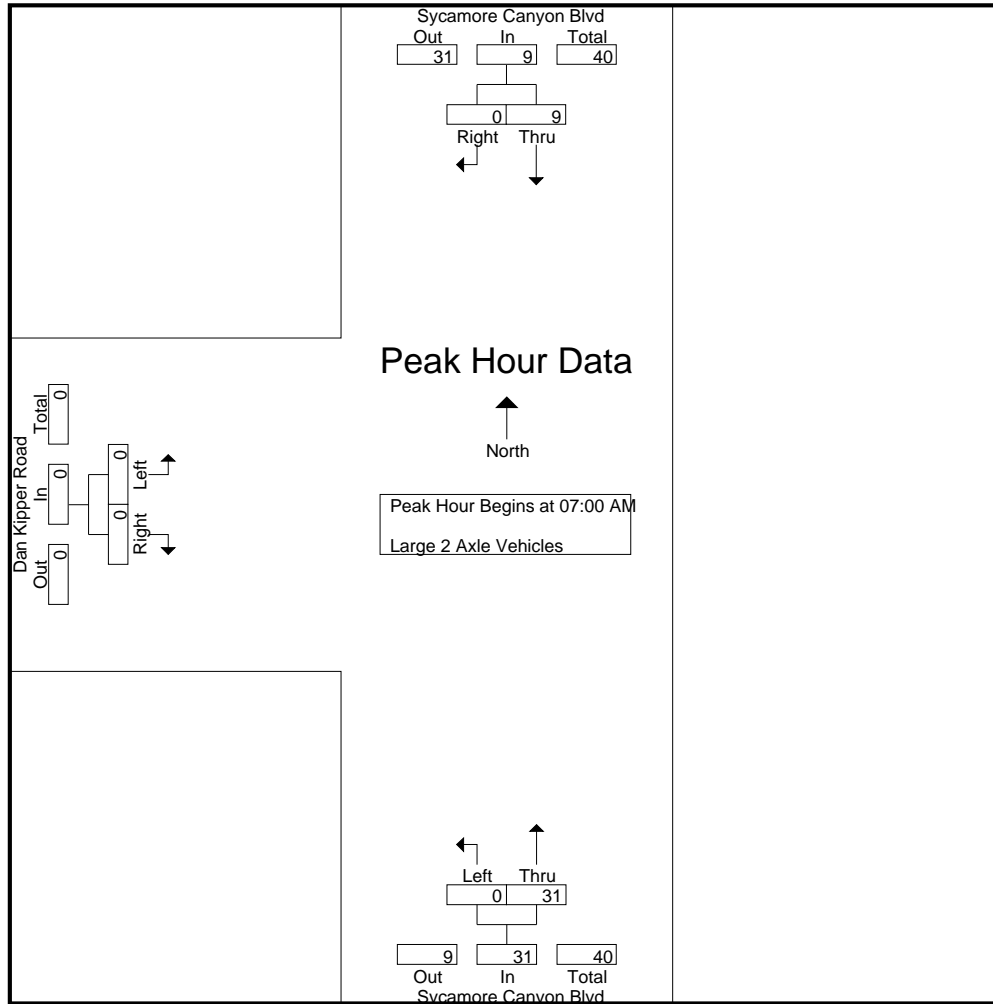

Peak Hour Analysis From 07:00 AM to 07:45 AM - Peak 1 of 1
 Peak Hour for Each Approach Begins at:

	07:00 AM			07:00 AM			07:00 AM		
+0 mins.	0	0	0	0	2	2	0	0	0
+15 mins.	1	0	1	0	10	10	0	0	0
+30 mins.	7	0	7	0	10	10	0	0	0
+45 mins.	1	0	1	0	9	9	0	0	0
Total Volume	9	0	9	0	31	31	0	0	0
% App. Total	100	0	100	0	100	100	0	0	0
PHF	.321	.000	.321	.000	.775	.775	.000	.000	.000

City of Riverside
 N/S: Sycamore Canyon Blvd
 E/W: Dan Kipper Road
 Weather: Clear

File Name : RIVSCDKAM
 Site Code : 06715392
 Start Date : 7/7/2015
 Page No : 1

Groups Printed- 3 Axle Vehicles

Start Time	Sycamore Canyon Blvd Southbound			Sycamore Canyon Blvd Northbound			Dan Kipper Road Eastbound			Int. Total
	Thru	Right	App. Total	Left	Thru	App. Total	Left	Right	App. Total	
07:00 AM	0	0	0	0	2	2	0	0	0	2
07:15 AM	0	0	0	0	0	0	0	0	0	0
07:30 AM	2	0	2	0	2	2	0	0	0	4
07:45 AM	0	0	0	0	1	1	0	0	0	1
Total	2	0	2	0	5	5	0	0	0	7
08:00 AM	1	0	1	0	2	2	0	0	0	3
08:15 AM	1	0	1	0	2	2	0	0	0	3
08:30 AM	2	0	2	1	1	2	0	0	0	4
08:45 AM	0	0	0	0	1	1	0	0	0	1
Total	4	0	4	1	6	7	0	0	0	11
Grand Total	6	0	6	1	11	12	0	0	0	18
Apprch %	100	0		8.3	91.7		0	0		
Total %	33.3	0	33.3	5.6	61.1	66.7	0	0	0	

Start Time	Sycamore Canyon Blvd Southbound			Sycamore Canyon Blvd Northbound			Dan Kipper Road Eastbound			Int. Total
	Thru	Right	App. Total	Left	Thru	App. Total	Left	Right	App. Total	
07:00 AM	0	0	0	0	2	2	0	0	0	2
07:15 AM	0	0	0	0	0	0	0	0	0	0
07:30 AM	2	0	2	0	2	2	0	0	0	4
07:45 AM	0	0	0	0	1	1	0	0	0	1
Total Volume	2	0	2	0	5	5	0	0	0	7
% App. Total	100	0		0	100		0	0		
PHF	.250	.000	.250	.000	.625	.625	.000	.000	.000	.438

Peak Hour Analysis From 07:00 AM to 07:45 AM - Peak 1 of 1
 Peak Hour for Entire Intersection Begins at 07:00 AM

City of Riverside
 N/S: Sycamore Canyon Blvd
 E/W: Dan Kipper Road
 Weather: Clear

File Name : RIVSCDKAM
 Site Code : 06715392
 Start Date : 7/7/2015
 Page No : 2

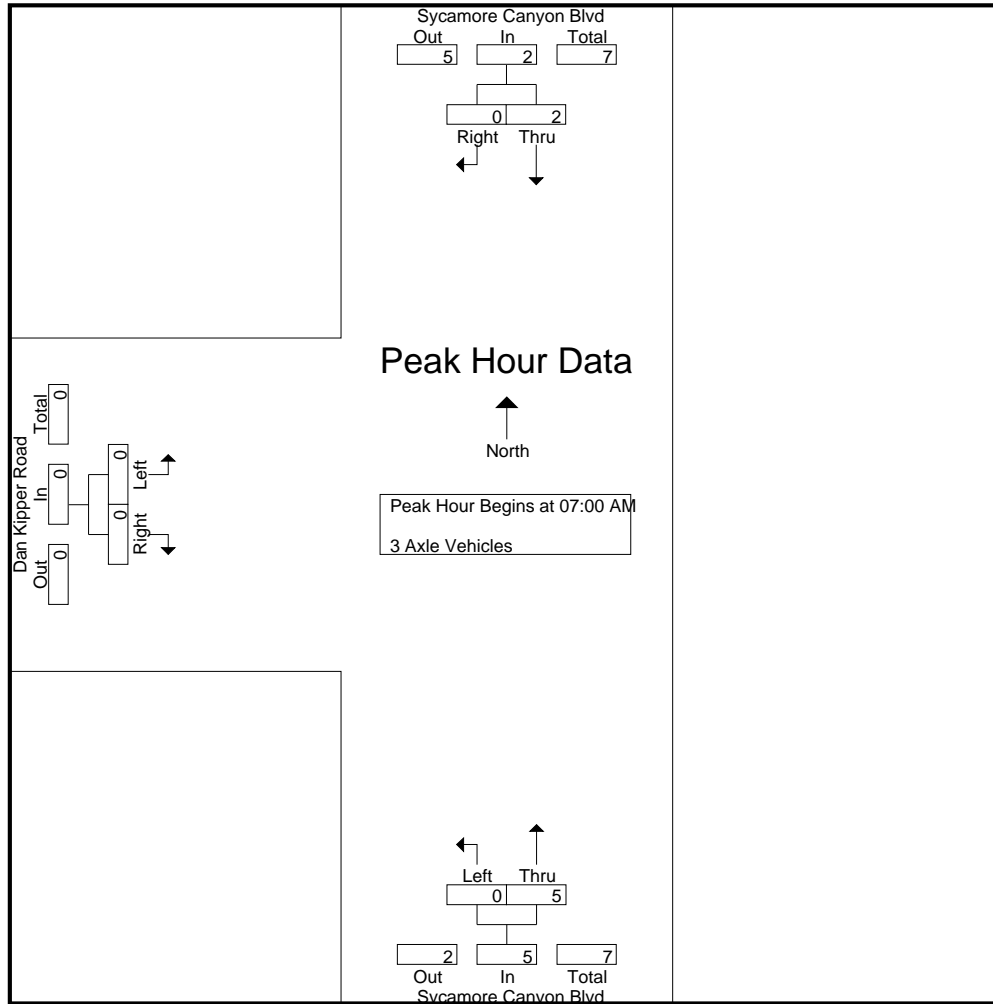

Peak Hour Analysis From 07:00 AM to 07:45 AM - Peak 1 of 1
 Peak Hour for Each Approach Begins at:

	07:00 AM			07:00 AM			07:00 AM		
+0 mins.	0	0	0	0	2	2	0	0	0
+15 mins.	0	0	0	0	0	0	0	0	0
+30 mins.	2	0	2	0	2	2	0	0	0
+45 mins.	0	0	0	0	1	1	0	0	0
Total Volume	2	0	2	0	5	5	0	0	0
% App. Total	100	0		0	100		0	0	
PHF	.250	.000	.250	.000	.625	.625	.000	.000	.000

City of Riverside
 N/S: Sycamore Canyon Blvd
 E/W: Dan Kipper Road
 Weather: Clear

File Name : RIVSCDKAM
 Site Code : 06715392
 Start Date : 7/7/2015
 Page No : 1

Groups Printed- 4+ Axle Trucks

Start Time	Sycamore Canyon Blvd Southbound			Sycamore Canyon Blvd Northbound			Dan Kipper Road Eastbound			Int. Total
	Thru	Right	App. Total	Left	Thru	App. Total	Left	Right	App. Total	
07:00 AM	3	0	3	0	5	5	0	0	0	8
07:15 AM	5	0	5	0	10	10	0	0	0	15
07:30 AM	2	0	2	0	12	12	0	0	0	14
07:45 AM	5	0	5	0	13	13	0	0	0	18
Total	15	0	15	0	40	40	0	0	0	55
08:00 AM	2	0	2	0	12	12	0	0	0	14
08:15 AM	7	0	7	0	11	11	0	0	0	18
08:30 AM	3	0	3	0	16	16	0	0	0	19
08:45 AM	2	0	2	0	12	12	0	0	0	14
Total	14	0	14	0	51	51	0	0	0	65
Grand Total	29	0	29	0	91	91	0	0	0	120
Apprch %	100	0		0	100		0	0		
Total %	24.2	0	24.2	0	75.8	75.8	0	0	0	

Start Time	Sycamore Canyon Blvd Southbound			Sycamore Canyon Blvd Northbound			Dan Kipper Road Eastbound			Int. Total
	Thru	Right	App. Total	Left	Thru	App. Total	Left	Right	App. Total	
07:00 AM	3	0	3	0	5	5	0	0	0	8
07:15 AM	5	0	5	0	10	10	0	0	0	15
07:30 AM	2	0	2	0	12	12	0	0	0	14
07:45 AM	5	0	5	0	13	13	0	0	0	18
Total Volume	15	0	15	0	40	40	0	0	0	55
% App. Total	100	0		0	100		0	0		
PHF	.750	.000	.750	.000	.769	.769	.000	.000	.000	.764

Peak Hour Analysis From 07:00 AM to 07:45 AM - Peak 1 of 1
 Peak Hour for Entire Intersection Begins at 07:00 AM

City of Riverside
 N/S: Sycamore Canyon Blvd
 E/W: Dan Kipper Road
 Weather: Clear

File Name : RIVSCDKAM
 Site Code : 06715392
 Start Date : 7/7/2015
 Page No : 2

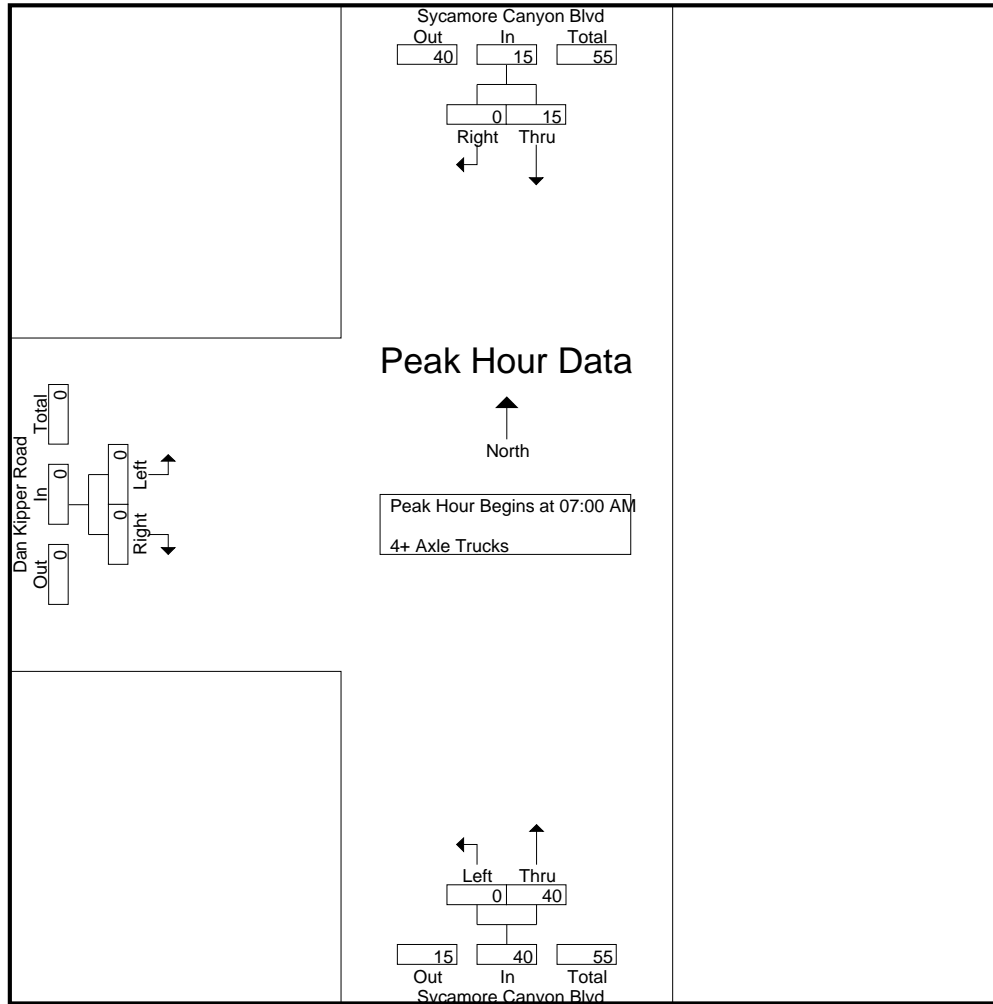

Peak Hour Analysis From 07:00 AM to 07:45 AM - Peak 1 of 1
 Peak Hour for Each Approach Begins at:

	07:00 AM			07:00 AM			07:00 AM		
+0 mins.	3	0	3	0	5	5	0	0	0
+15 mins.	5	0	5	0	10	10	0	0	0
+30 mins.	2	0	2	0	12	12	0	0	0
+45 mins.	5	0	5	0	13	13	0	0	0
Total Volume	15	0	15	0	40	40	0	0	0
% App. Total	100	0		0	100		0	0	
PHF	.750	.000	.750	.000	.769	.769	.000	.000	.000

City of Riverside
 N/S: Sycamore Canyon Blvd
 E/W: Dan Kipper Road
 Weather: Clear

File Name : RIVSCDKPM
 Site Code : 06715392
 Start Date : 7/7/2015
 Page No : 1

Groups Printed- Passenger Vehicles - Large 2 Axle Vehicles - 3 Axle Vehicles - 4+ Axle Trucks

Start Time	Sycamore Canyon Blvd Southbound			Sycamore Canyon Blvd Northbound			Dan Kipper Road Eastbound			Int. Total
	Thru	Right	App. Total	Left	Thru	App. Total	Left	Right	App. Total	
04:00 PM	121	2	123	5	199	204	0	0	0	327
04:15 PM	83	1	84	0	150	150	0	0	0	234
04:30 PM	91	1	92	0	213	213	0	0	0	305
04:45 PM	108	0	108	0	140	140	0	0	0	248
Total	403	4	407	5	702	707	0	0	0	1114
05:00 PM	108	0	108	0	250	250	0	0	0	358
05:15 PM	111	1	112	1	169	170	0	1	1	283
05:30 PM	90	0	90	0	106	106	0	0	0	196
05:45 PM	100	0	100	0	112	112	0	0	0	212
Total	409	1	410	1	637	638	0	1	1	1049
Grand Total	812	5	817	6	1339	1345	0	1	1	2163
Apprch %	99.4	0.6		0.4	99.6		0	100		
Total %	37.5	0.2	37.8	0.3	61.9	62.2	0	0	0	
Passenger Vehicles	776	3	779	6	1278	1284	0	1	1	2064
% Passenger Vehicles	95.6	60	95.3	100	95.4	95.5	0	100	100	95.4
Large 2 Axle Vehicles	6	1	7	0	17	17	0	0	0	24
% Large 2 Axle Vehicles	0.7	20	0.9	0	1.3	1.3	0	0	0	1.1
3 Axle Vehicles	9	0	9	0	7	7	0	0	0	16
% 3 Axle Vehicles	1.1	0	1.1	0	0.5	0.5	0	0	0	0.7
4+ Axle Trucks	21	1	22	0	37	37	0	0	0	59
% 4+ Axle Trucks	2.6	20	2.7	0	2.8	2.8	0	0	0	2.7

Start Time	Sycamore Canyon Blvd Southbound			Sycamore Canyon Blvd Northbound			Dan Kipper Road Eastbound			Int. Total
	Thru	Right	App. Total	Left	Thru	App. Total	Left	Right	App. Total	
Peak Hour Analysis From 04:00 PM to 05:45 PM - Peak 1 of 1										
Peak Hour for Entire Intersection Begins at 04:30 PM										
04:30 PM	91	1	92	0	213	213	0	0	0	305
04:45 PM	108	0	108	0	140	140	0	0	0	248
05:00 PM	108	0	108	0	250	250	0	0	0	358
05:15 PM	111	1	112	1	169	170	0	1	1	283
Total Volume	418	2	420	1	772	773	0	1	1	1194
% App. Total	99.5	0.5		0.1	99.9		0	100		
PHF	.941	.500	.938	.250	.772	.773	.000	.250	.250	.834

City of Riverside
 N/S: Sycamore Canyon Blvd
 E/W: Dan Kipper Road
 Weather: Clear

File Name : RIVSCDKPM
 Site Code : 06715392
 Start Date : 7/7/2015
 Page No : 2

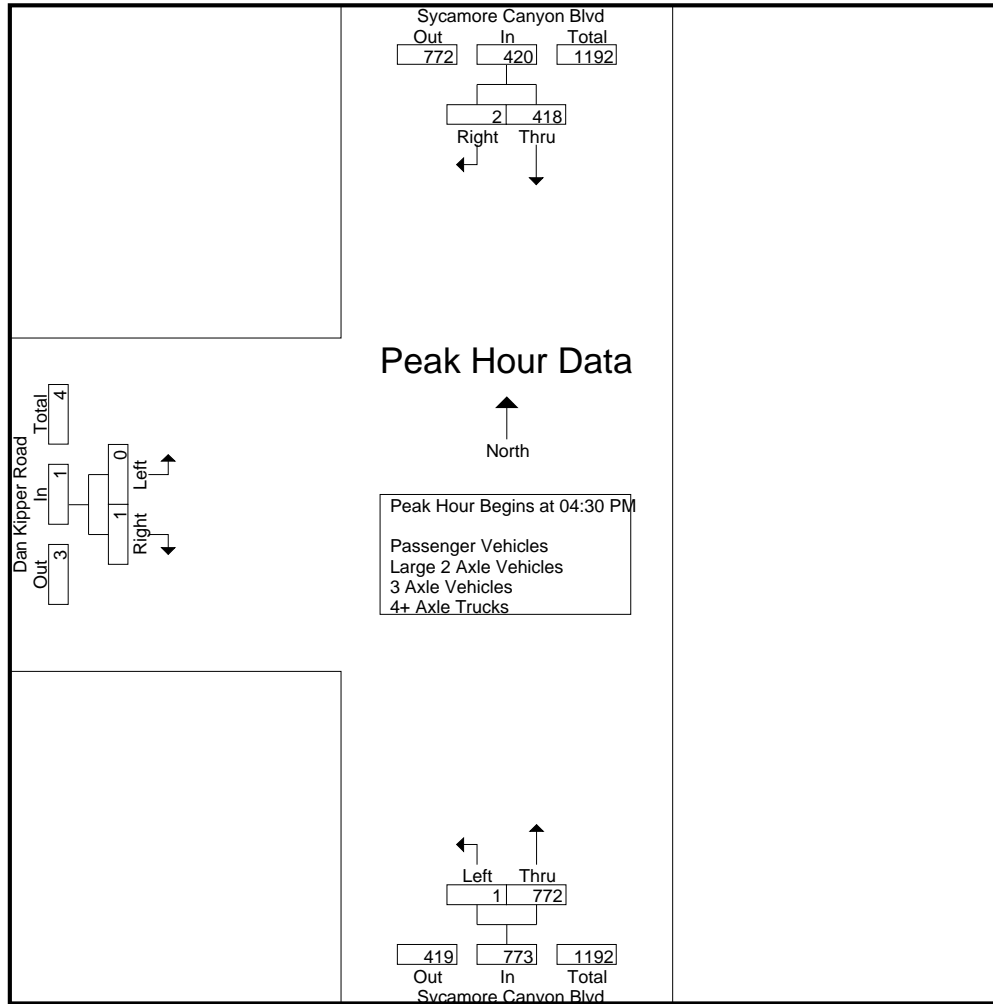

Peak Hour Analysis From 04:00 PM to 05:45 PM - Peak 1 of 1
 Peak Hour for Each Approach Begins at:

	04:30 PM			04:30 PM			04:30 PM		
+0 mins.	91	1	92	0	213	213	0	0	0
+15 mins.	108	0	108	0	140	140	0	0	0
+30 mins.	108	0	108	0	250	250	0	0	0
+45 mins.	111	1	112	1	169	170	0	1	1
Total Volume	418	2	420	1	772	773	0	1	1
% App. Total	99.5	0.5		0.1	99.9		0	100	
PHF	.941	.500	.938	.250	.772	.773	.000	.250	.250

City of Riverside
 N/S: Sycamore Canyon Blvd
 E/W: Dan Kipper Road
 Weather: Clear

File Name : RIVSCDKPM
 Site Code : 06715392
 Start Date : 7/7/2015
 Page No : 1

Groups Printed- Passenger Vehicles

Start Time	Sycamore Canyon Blvd Southbound			Sycamore Canyon Blvd Northbound			Dan Kipper Road Eastbound			Int. Total
	Thru	Right	App. Total	Left	Thru	App. Total	Left	Right	App. Total	
04:00 PM	112	2	114	5	188	193	0	0	0	307
04:15 PM	80	0	80	0	144	144	0	0	0	224
04:30 PM	86	0	86	0	204	204	0	0	0	290
04:45 PM	105	0	105	0	134	134	0	0	0	239
Total	383	2	385	5	670	675	0	0	0	1060
05:00 PM	101	0	101	0	242	242	0	0	0	343
05:15 PM	108	1	109	1	160	161	0	1	1	271
05:30 PM	86	0	86	0	100	100	0	0	0	186
05:45 PM	98	0	98	0	106	106	0	0	0	204
Total	393	1	394	1	608	609	0	1	1	1004
Grand Total	776	3	779	6	1278	1284	0	1	1	2064
Apprch %	99.6	0.4		0.5	99.5		0	100		
Total %	37.6	0.1	37.7	0.3	61.9	62.2	0	0	0	

Start Time	Sycamore Canyon Blvd Southbound			Sycamore Canyon Blvd Northbound			Dan Kipper Road Eastbound			Int. Total
	Thru	Right	App. Total	Left	Thru	App. Total	Left	Right	App. Total	
04:30 PM	86	0	86	0	204	204	0	0	0	290
04:45 PM	105	0	105	0	134	134	0	0	0	239
05:00 PM	101	0	101	0	242	242	0	0	0	343
05:15 PM	108	1	109	1	160	161	0	1	1	271
Total Volume	400	1	401	1	740	741	0	1	1	1143
% App. Total	99.8	0.2		0.1	99.9		0	100		
PHF	.926	.250	.920	.250	.764	.765	.000	.250	.250	.833

Peak Hour Analysis From 04:30 PM to 05:15 PM - Peak 1 of 1
 Peak Hour for Entire Intersection Begins at 04:30 PM

City of Riverside
 N/S: Sycamore Canyon Blvd
 E/W: Dan Kipper Road
 Weather: Clear

File Name : RIVSCDKPM
 Site Code : 06715392
 Start Date : 7/7/2015
 Page No : 2

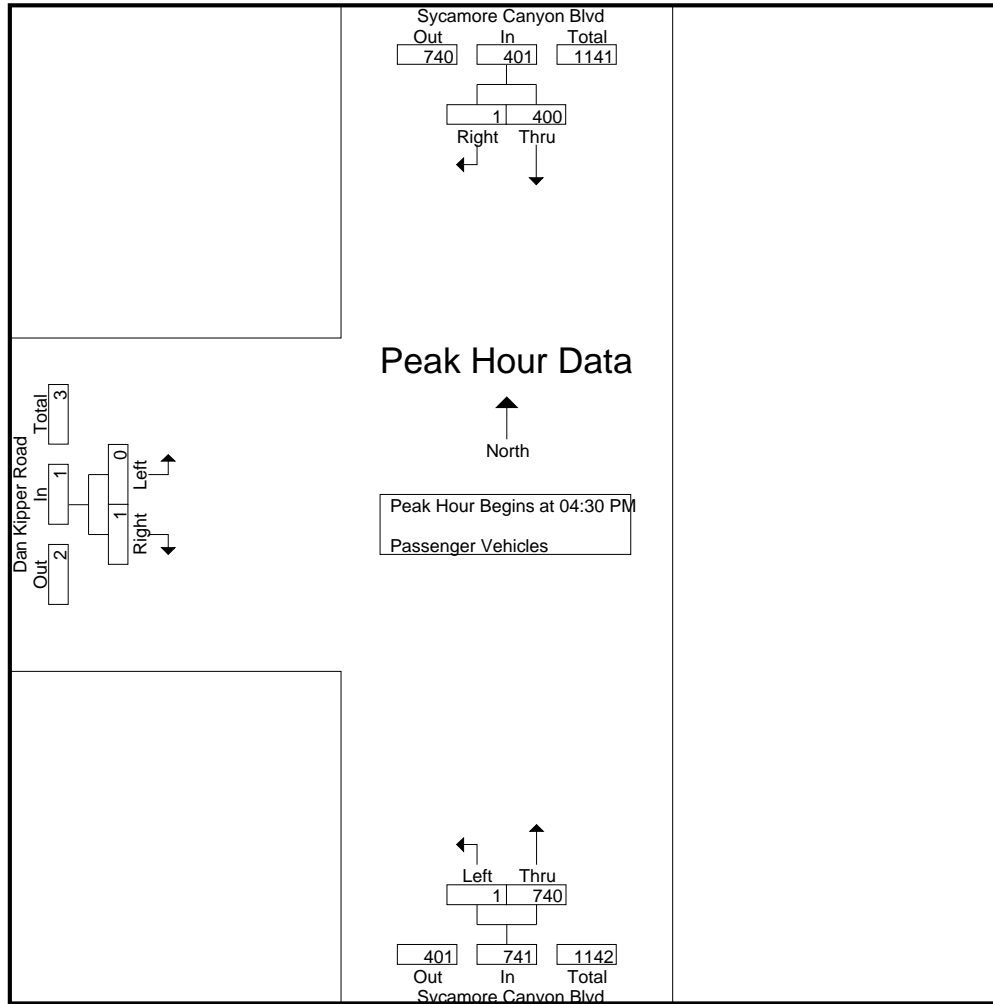

Peak Hour Analysis From 04:30 PM to 05:15 PM - Peak 1 of 1
 Peak Hour for Each Approach Begins at:

	04:30 PM			04:30 PM			04:30 PM		
+0 mins.	86	0	86	0	204	204	0	0	0
+15 mins.	105	0	105	0	134	134	0	0	0
+30 mins.	101	0	101	0	242	242	0	0	0
+45 mins.	108	1	109	1	160	161	0	1	1
Total Volume	400	1	401	1	740	741	0	1	1
% App. Total	99.8	0.2		0.1	99.9		0	100	
PHF	.926	.250	.920	.250	.764	.765	.000	.250	.250

City of Riverside
 N/S: Sycamore Canyon Blvd
 E/W: Dan Kipper Road
 Weather: Clear

File Name : RIVSCDKPM
 Site Code : 06715392
 Start Date : 7/7/2015
 Page No : 1

Groups Printed- Large 2 Axle Vehicles

Start Time	Sycamore Canyon Blvd Southbound			Sycamore Canyon Blvd Northbound			Dan Kipper Road Eastbound			Int. Total
	Thru	Right	App. Total	Left	Thru	App. Total	Left	Right	App. Total	
04:00 PM	1	0	1	0	3	3	0	0	0	4
04:15 PM	0	0	0	0	0	0	0	0	0	0
04:30 PM	2	1	3	0	4	4	0	0	0	7
04:45 PM	0	0	0	0	3	3	0	0	0	3
Total	3	1	4	0	10	10	0	0	0	14
05:00 PM	1	0	1	0	3	3	0	0	0	4
05:15 PM	1	0	1	0	1	1	0	0	0	2
05:30 PM	1	0	1	0	1	1	0	0	0	2
05:45 PM	0	0	0	0	2	2	0	0	0	2
Total	3	0	3	0	7	7	0	0	0	10
Grand Total	6	1	7	0	17	17	0	0	0	24
Apprch %	85.7	14.3		0	100		0	0		
Total %	25	4.2	29.2	0	70.8	70.8	0	0	0	

Start Time	Sycamore Canyon Blvd Southbound			Sycamore Canyon Blvd Northbound			Dan Kipper Road Eastbound			Int. Total
	Thru	Right	App. Total	Left	Thru	App. Total	Left	Right	App. Total	
04:30 PM	2	1	3	0	4	4	0	0	0	7
04:45 PM	0	0	0	0	3	3	0	0	0	3
05:00 PM	1	0	1	0	3	3	0	0	0	4
05:15 PM	1	0	1	0	1	1	0	0	0	2
Total Volume	4	1	5	0	11	11	0	0	0	16
% App. Total	80	20		0	100		0	0		
PHF	.500	.250	.417	.000	.688	.688	.000	.000	.000	.571

Peak Hour Analysis From 04:30 PM to 05:15 PM - Peak 1 of 1
 Peak Hour for Entire Intersection Begins at 04:30 PM

City of Riverside
 N/S: Sycamore Canyon Blvd
 E/W: Dan Kipper Road
 Weather: Clear

File Name : RIVSCDKPM
 Site Code : 06715392
 Start Date : 7/7/2015
 Page No : 2

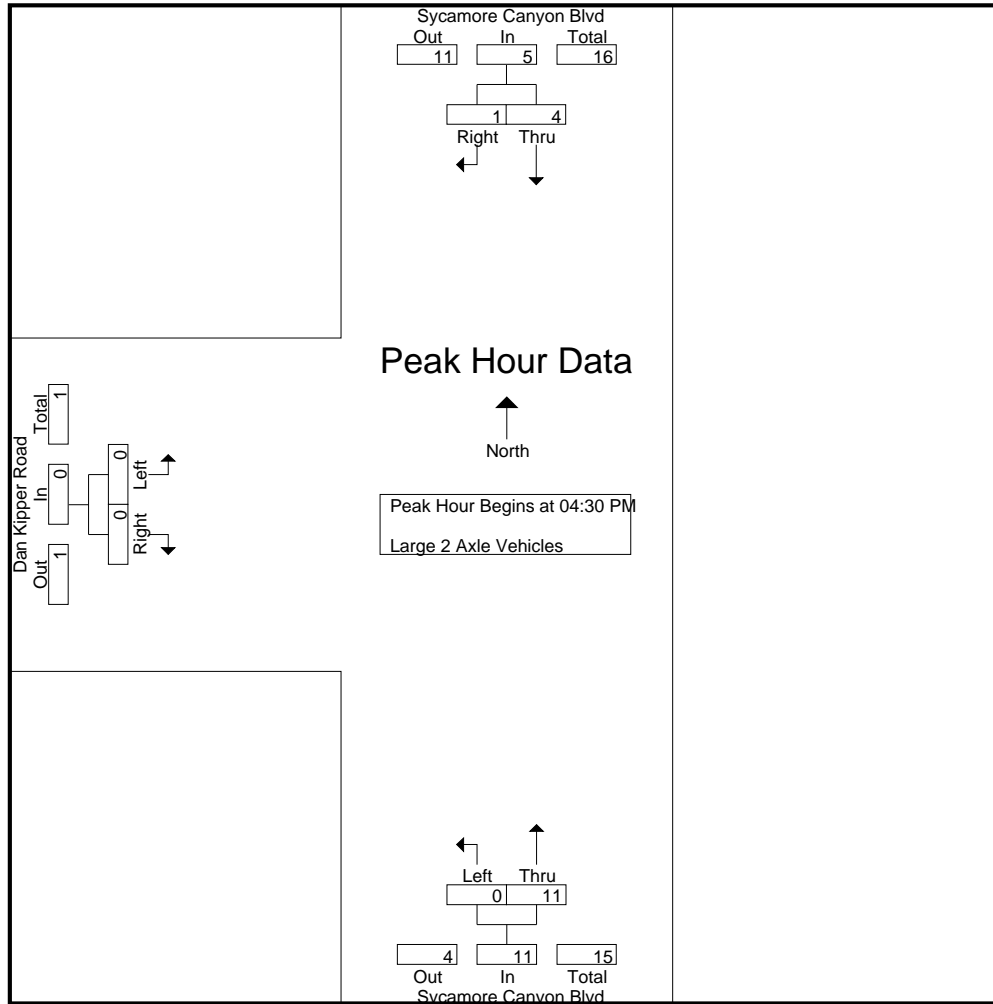

Peak Hour Analysis From 04:30 PM to 05:15 PM - Peak 1 of 1
 Peak Hour for Each Approach Begins at:

	04:30 PM			04:30 PM			04:30 PM		
+0 mins.	2	1	3	0	4	4	0	0	0
+15 mins.	0	0	0	0	3	3	0	0	0
+30 mins.	1	0	1	0	3	3	0	0	0
+45 mins.	1	0	1	0	1	1	0	0	0
Total Volume	4	1	5	0	11	11	0	0	0
% App. Total	80	20		0	100		0	0	
PHF	.500	.250	.417	.000	.688	.688	.000	.000	.000

City of Riverside
 N/S: Sycamore Canyon Blvd
 E/W: Dan Kipper Road
 Weather: Clear

File Name : RIVSCDKPM
 Site Code : 06715392
 Start Date : 7/7/2015
 Page No : 1

Groups Printed- 3 Axle Vehicles

Start Time	Sycamore Canyon Blvd Southbound			Sycamore Canyon Blvd Northbound			Dan Kipper Road Eastbound			Int. Total
	Thru	Right	App. Total	Left	Thru	App. Total	Left	Right	App. Total	
04:00 PM	2	0	2	0	2	2	0	0	0	4
04:15 PM	0	0	0	0	1	1	0	0	0	1
04:30 PM	3	0	3	0	0	0	0	0	0	3
04:45 PM	1	0	1	0	0	0	0	0	0	1
Total	6	0	6	0	3	3	0	0	0	9
05:00 PM	3	0	3	0	1	1	0	0	0	4
05:15 PM	0	0	0	0	1	1	0	0	0	1
05:30 PM	0	0	0	0	1	1	0	0	0	1
05:45 PM	0	0	0	0	1	1	0	0	0	1
Total	3	0	3	0	4	4	0	0	0	7
Grand Total	9	0	9	0	7	7	0	0	0	16
Apprch %	100	0		0	100		0	0		
Total %	56.2	0	56.2	0	43.8	43.8	0	0	0	

Start Time	Sycamore Canyon Blvd Southbound			Sycamore Canyon Blvd Northbound			Dan Kipper Road Eastbound			Int. Total
	Thru	Right	App. Total	Left	Thru	App. Total	Left	Right	App. Total	
04:30 PM	3	0	3	0	0	0	0	0	0	3
04:45 PM	1	0	1	0	0	0	0	0	0	1
05:00 PM	3	0	3	0	1	1	0	0	0	4
05:15 PM	0	0	0	0	1	1	0	0	0	1
Total Volume	7	0	7	0	2	2	0	0	0	9
% App. Total	100	0		0	100		0	0		
PHF	.583	.000	.583	.000	.500	.500	.000	.000	.000	.563

Peak Hour Analysis From 04:30 PM to 05:15 PM - Peak 1 of 1
 Peak Hour for Entire Intersection Begins at 04:30 PM

City of Riverside
 N/S: Sycamore Canyon Blvd
 E/W: Dan Kipper Road
 Weather: Clear

File Name : RIVSCDKPM
 Site Code : 06715392
 Start Date : 7/7/2015
 Page No : 2

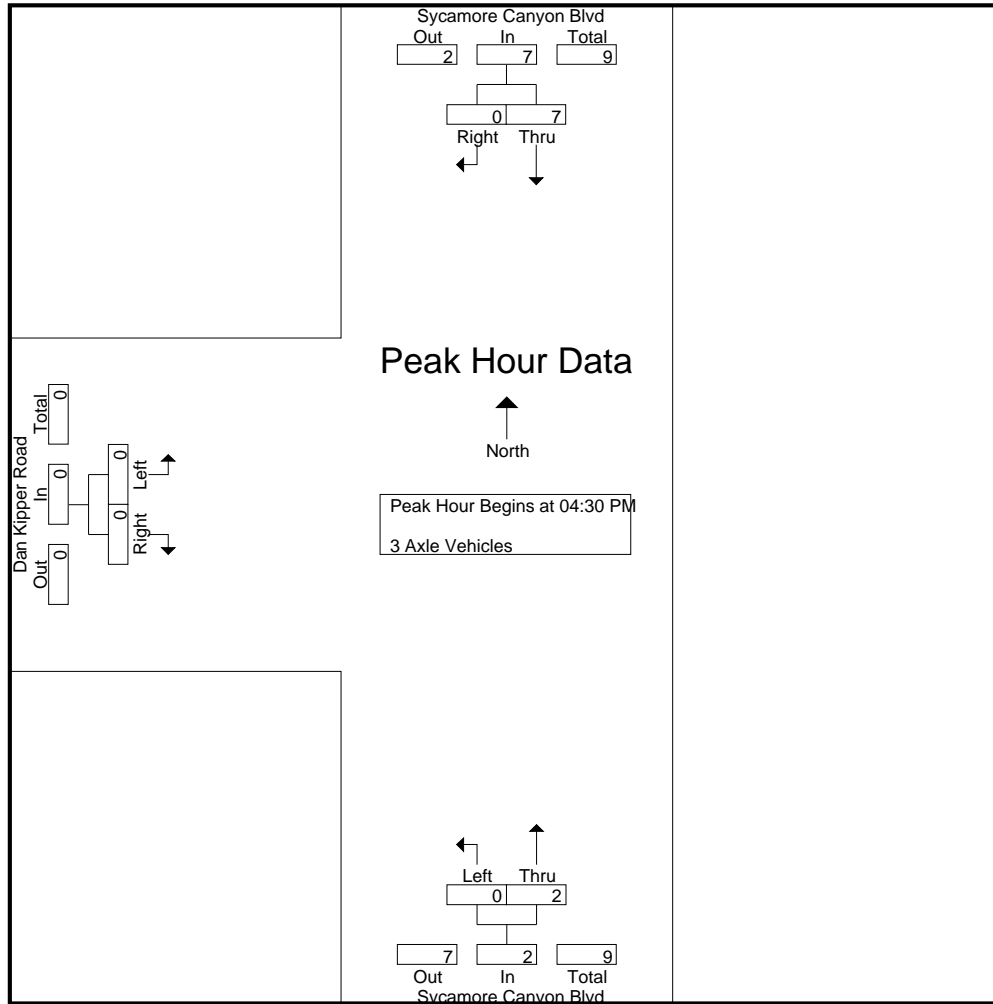

Peak Hour Analysis From 04:30 PM to 05:15 PM - Peak 1 of 1
 Peak Hour for Each Approach Begins at:

	04:30 PM			04:30 PM			04:30 PM		
+0 mins.	3	0	3	0	0	0	0	0	0
+15 mins.	1	0	1	0	0	0	0	0	0
+30 mins.	3	0	3	0	1	1	0	0	0
+45 mins.	0	0	0	0	1	1	0	0	0
Total Volume	7	0	7	0	2	2	0	0	0
% App. Total	100	0		0	100		0	0	
PHF	.583	.000	.583	.000	.500	.500	.000	.000	.000

City of Riverside
 N/S: Sycamore Canyon Blvd
 E/W: Dan Kipper Road
 Weather: Clear

File Name : RIVSCDKPM
 Site Code : 06715392
 Start Date : 7/7/2015
 Page No : 1

Groups Printed- 4+ Axle Trucks

Start Time	Sycamore Canyon Blvd Southbound			Sycamore Canyon Blvd Northbound			Dan Kipper Road Eastbound			Int. Total
	Thru	Right	App. Total	Left	Thru	App. Total	Left	Right	App. Total	
04:00 PM	6	0	6	0	6	6	0	0	0	12
04:15 PM	3	1	4	0	5	5	0	0	0	9
04:30 PM	0	0	0	0	5	5	0	0	0	5
04:45 PM	2	0	2	0	3	3	0	0	0	5
Total	11	1	12	0	19	19	0	0	0	31
05:00 PM	3	0	3	0	4	4	0	0	0	7
05:15 PM	2	0	2	0	7	7	0	0	0	9
05:30 PM	3	0	3	0	4	4	0	0	0	7
05:45 PM	2	0	2	0	3	3	0	0	0	5
Total	10	0	10	0	18	18	0	0	0	28
Grand Total	21	1	22	0	37	37	0	0	0	59
Apprch %	95.5	4.5		0	100		0	0		
Total %	35.6	1.7	37.3	0	62.7	62.7	0	0	0	

Start Time	Sycamore Canyon Blvd Southbound			Sycamore Canyon Blvd Northbound			Dan Kipper Road Eastbound			Int. Total
	Thru	Right	App. Total	Left	Thru	App. Total	Left	Right	App. Total	
04:30 PM	0	0	0	0	5	5	0	0	0	5
04:45 PM	2	0	2	0	3	3	0	0	0	5
05:00 PM	3	0	3	0	4	4	0	0	0	7
05:15 PM	2	0	2	0	7	7	0	0	0	9
Total Volume	7	0	7	0	19	19	0	0	0	26
% App. Total	100	0		0	100		0	0		
PHF	.583	.000	.583	.000	.679	.679	.000	.000	.000	.722

Peak Hour Analysis From 04:30 PM to 05:15 PM - Peak 1 of 1
 Peak Hour for Entire Intersection Begins at 04:30 PM

City of Riverside
 N/S: Sycamore Canyon Blvd
 E/W: Dan Kipper Road
 Weather: Clear

File Name : RIVSCDKPM
 Site Code : 06715392
 Start Date : 7/7/2015
 Page No : 2

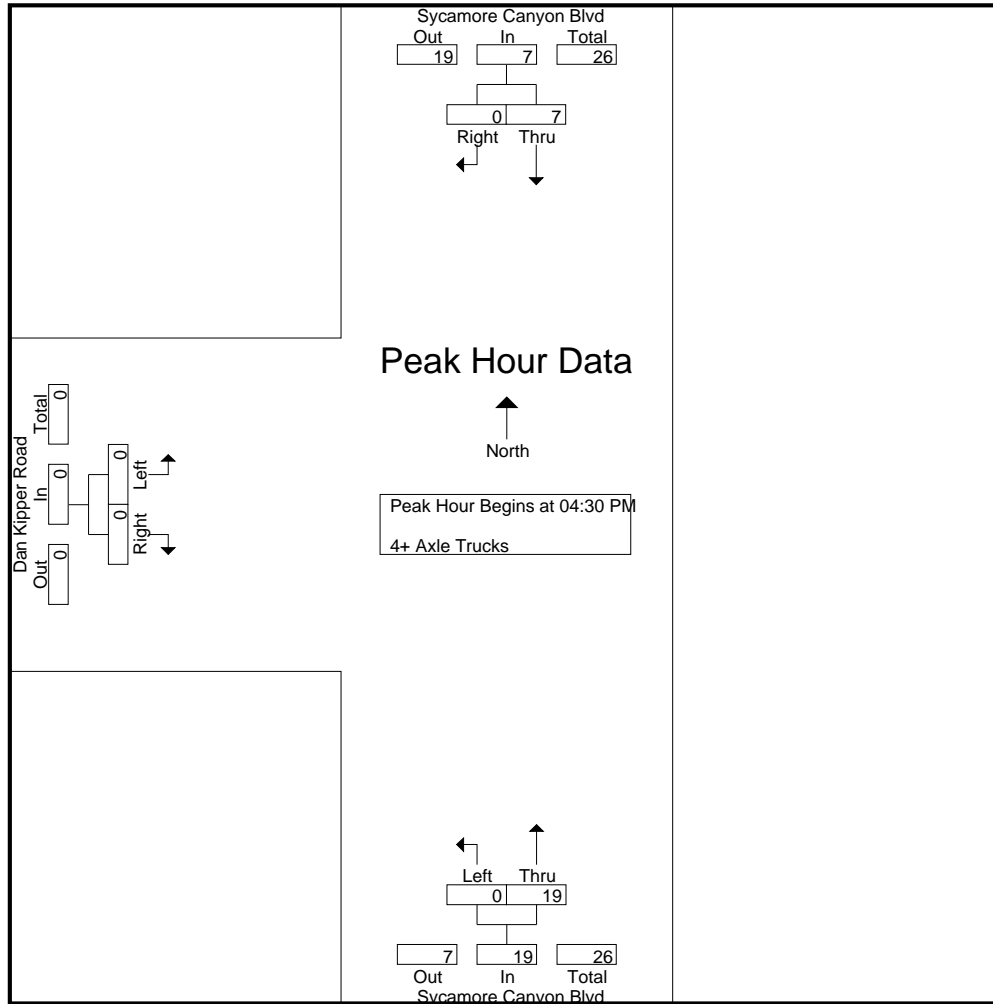

Peak Hour Analysis From 04:30 PM to 05:15 PM - Peak 1 of 1
 Peak Hour for Each Approach Begins at:

	04:30 PM			04:30 PM			04:30 PM		
+0 mins.	0	0	0	0	5	5	0	0	0
+15 mins.	2	0	2	0	3	3	0	0	0
+30 mins.	3	0	3	0	4	4	0	0	0
+45 mins.	2	0	2	0	7	7	0	0	0
Total Volume	7	0	7	0	19	19	0	0	0
% App. Total	100	0		0	100		0	0	
PHF	.583	.000	.583	.000	.679	.679	.000	.000	.000

City of Riverside
 N/S: Sycamore Canyon Blvd
 E/W: Box Springs Blvd
 Weather: Clear

File Name : RIVSCBBAM
 Site Code : 06715392
 Start Date : 7/7/2015
 Page No : 1

Groups Printed- Passenger Vehicles - Large 2 Axle Vehicles - 3 Axle Vehicles - 4+ Axle Trucks

Start Time	Sycamore Canyon Blvd Southbound				Box Springs Blvd Westbound				Sycamore Canyon Blvd Northbound				Box Springs Blvd Eastbound				Int. Total
	Left	Thru	Right	App. Total	Left	Thru	Right	App. Total	Left	Thru	Right	App. Total	Left	Thru	Right	App. Total	
07:00 AM	19	64	0	83	3	0	37	40	0	266	4	270	0	0	0	0	393
07:15 AM	27	68	0	95	5	0	66	71	0	271	1	272	0	0	0	0	438
07:30 AM	38	78	0	116	2	0	73	75	0	299	4	303	0	0	0	0	494
07:45 AM	41	101	0	142	3	0	40	43	0	265	9	274	0	0	0	0	459
Total	125	311	0	436	13	0	216	229	0	1101	18	1119	0	0	0	0	1784
08:00 AM	39	53	0	92	2	0	53	55	0	230	4	234	0	0	0	0	381
08:15 AM	28	44	0	72	0	0	32	32	0	214	4	218	0	0	0	0	322
08:30 AM	17	56	0	73	0	0	23	23	0	209	4	213	0	0	0	0	309
08:45 AM	31	52	0	83	4	0	29	33	0	123	4	127	0	0	0	0	243
Total	115	205	0	320	6	0	137	143	0	776	16	792	0	0	0	0	1255
Grand Total	240	516	0	756	19	0	353	372	0	1877	34	1911	0	0	0	0	3039
Apprch %	31.7	68.3	0		5.1	0	94.9		0	98.2	1.8		0	0	0		
Total %	7.9	17	0	24.9	0.6	0	11.6	12.2	0	61.8	1.1	62.9	0	0	0	0	
Passenger Vehicles	229	490	0	719	13	0	335	348	0	1742	21	1763	0	0	0	0	2830
% Passenger Vehicles	95.4	95	0	95.1	68.4	0	94.9	93.5	0	92.8	61.8	92.3	0	0	0	0	93.1
Large 2 Axle Vehicles	6	13	0	19	2	0	8	10	0	41	3	44	0	0	0	0	73
% Large 2 Axle Vehicles	2.5	2.5	0	2.5	10.5	0	2.3	2.7	0	2.2	8.8	2.3	0	0	0	0	2.4
3 Axle Vehicles	2	2	0	4	2	0	5	7	0	12	2	14	0	0	0	0	25
% 3 Axle Vehicles	0.8	0.4	0	0.5	10.5	0	1.4	1.9	0	0.6	5.9	0.7	0	0	0	0	0.8
4+ Axle Trucks	3	11	0	14	2	0	5	7	0	82	8	90	0	0	0	0	111
% 4+ Axle Trucks	1.2	2.1	0	1.9	10.5	0	1.4	1.9	0	4.4	23.5	4.7	0	0	0	0	3.7

Start Time	Sycamore Canyon Blvd Southbound				Box Springs Blvd Westbound				Sycamore Canyon Blvd Northbound				Box Springs Blvd Eastbound				Int. Total
	Left	Thru	Right	App. Total	Left	Thru	Right	App. Total	Left	Thru	Right	App. Total	Left	Thru	Right	App. Total	
07:00 AM	19	64	0	83	3	0	37	40	0	266	4	270	0	0	0	0	393
07:15 AM	27	68	0	95	5	0	66	71	0	271	1	272	0	0	0	0	438
07:30 AM	38	78	0	116	2	0	73	75	0	299	4	303	0	0	0	0	494
07:45 AM	41	101	0	142	3	0	40	43	0	265	9	274	0	0	0	0	459
Total Volume	125	311	0	436	13	0	216	229	0	1101	18	1119	0	0	0	0	1784
% App. Total	28.7	71.3	0		5.7	0	94.3		0	98.4	1.6		0	0	0		
PHF	.762	.770	.000	.768	.650	.000	.740	.763	.000	.921	.500	.923	.000	.000	.000	.000	.903

Peak Hour Analysis From 07:00 AM to 08:45 AM - Peak 1 of 1

Peak Hour for Entire Intersection Begins at 07:00 AM

City of Riverside
 N/S: Sycamore Canyon Blvd
 E/W: Box Springs Blvd
 Weather: Clear

File Name : RIVSCBBAM
 Site Code : 06715392
 Start Date : 7/7/2015
 Page No : 2

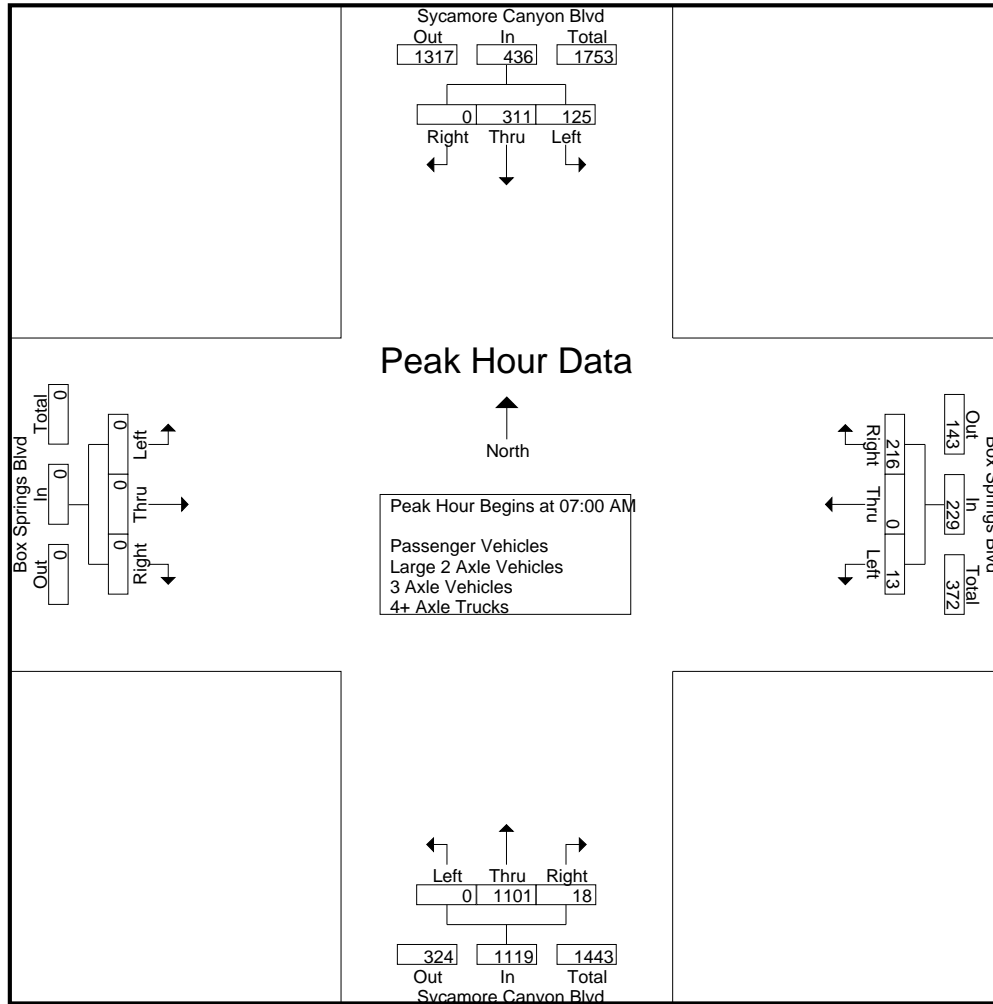

Peak Hour Analysis From 07:00 AM to 08:45 AM - Peak 1 of 1
 Peak Hour for Each Approach Begins at:

	07:15 AM				07:15 AM				07:00 AM				07:00 AM			
+0 mins.	27	68	0	95	5	0	66	71	0	266	4	270	0	0	0	0
+15 mins.	38	78	0	116	2	0	73	75	0	271	1	272	0	0	0	0
+30 mins.	41	101	0	142	3	0	40	43	0	299	4	303	0	0	0	0
+45 mins.	39	53	0	92	2	0	53	55	0	265	9	274	0	0	0	0
Total Volume	145	300	0	445	12	0	232	244	0	1101	18	1119	0	0	0	0
% App. Total	32.6	67.4	0		4.9	0	95.1		0	98.4	1.6		0	0	0	
PHF	.884	.743	.000	.783	.600	.000	.795	.813	.000	.921	.500	.923	.000	.000	.000	.000

City of Riverside
 N/S: Sycamore Canyon Blvd
 E/W: Box Springs Blvd
 Weather: Clear

File Name : RIVSCBBAM
 Site Code : 06715392
 Start Date : 7/7/2015
 Page No : 1

Groups Printed- Passenger Vehicles

Start Time	Sycamore Canyon Blvd Southbound				Box Springs Blvd Westbound				Sycamore Canyon Blvd Northbound				Box Springs Blvd Eastbound				Int. Total
	Left	Thru	Right	App. Total	Left	Thru	Right	App. Total	Left	Thru	Right	App. Total	Left	Thru	Right	App. Total	
07:00 AM	18	61	0	79	2	0	36	38	0	254	2	256	0	0	0	0	373
07:15 AM	26	62	0	88	3	0	65	68	0	259	1	260	0	0	0	0	416
07:30 AM	36	75	0	111	1	0	71	72	0	279	3	282	0	0	0	0	465
07:45 AM	41	99	0	140	2	0	38	40	0	248	5	253	0	0	0	0	433
Total	121	297	0	418	8	0	210	218	0	1040	11	1051	0	0	0	0	1687
08:00 AM	38	51	0	89	2	0	47	49	0	212	1	213	0	0	0	0	351
08:15 AM	28	41	0	69	0	0	29	29	0	196	4	200	0	0	0	0	298
08:30 AM	16	52	0	68	0	0	22	22	0	190	2	192	0	0	0	0	282
08:45 AM	26	49	0	75	3	0	27	30	0	104	3	107	0	0	0	0	212
Total	108	193	0	301	5	0	125	130	0	702	10	712	0	0	0	0	1143
Grand Total	229	490	0	719	13	0	335	348	0	1742	21	1763	0	0	0	0	2830
Apprch %	31.8	68.2	0		3.7	0	96.3		0	98.8	1.2		0	0	0		
Total %	8.1	17.3	0	25.4	0.5	0	11.8	12.3	0	61.6	0.7	62.3	0	0	0	0	

Start Time	Sycamore Canyon Blvd Southbound				Box Springs Blvd Westbound				Sycamore Canyon Blvd Northbound				Box Springs Blvd Eastbound				Int. Total
	Left	Thru	Right	App. Total	Left	Thru	Right	App. Total	Left	Thru	Right	App. Total	Left	Thru	Right	App. Total	
07:00 AM	18	61	0	79	2	0	36	38	0	254	2	256	0	0	0	0	373
07:15 AM	26	62	0	88	3	0	65	68	0	259	1	260	0	0	0	0	416
07:30 AM	36	75	0	111	1	0	71	72	0	279	3	282	0	0	0	0	465
07:45 AM	41	99	0	140	2	0	38	40	0	248	5	253	0	0	0	0	433
Total	121	297	0	418	8	0	210	218	0	1040	11	1051	0	0	0	0	1687
Total Volume																	
% App. Total	28.9	71.1	0		3.7	0	96.3		0	99	1		0	0	0		
PHF	.738	.750	.000	.746	.667	.000	.739	.757	.000	.932	.550	.932	.000	.000	.000	.000	.907

Peak Hour Analysis From 07:00 AM to 07:45 AM - Peak 1 of 1
 Peak Hour for Entire Intersection Begins at 07:00 AM

City of Riverside
 N/S: Sycamore Canyon Blvd
 E/W: Box Springs Blvd
 Weather: Clear

File Name : RIVSCBBAM
 Site Code : 06715392
 Start Date : 7/7/2015
 Page No : 2

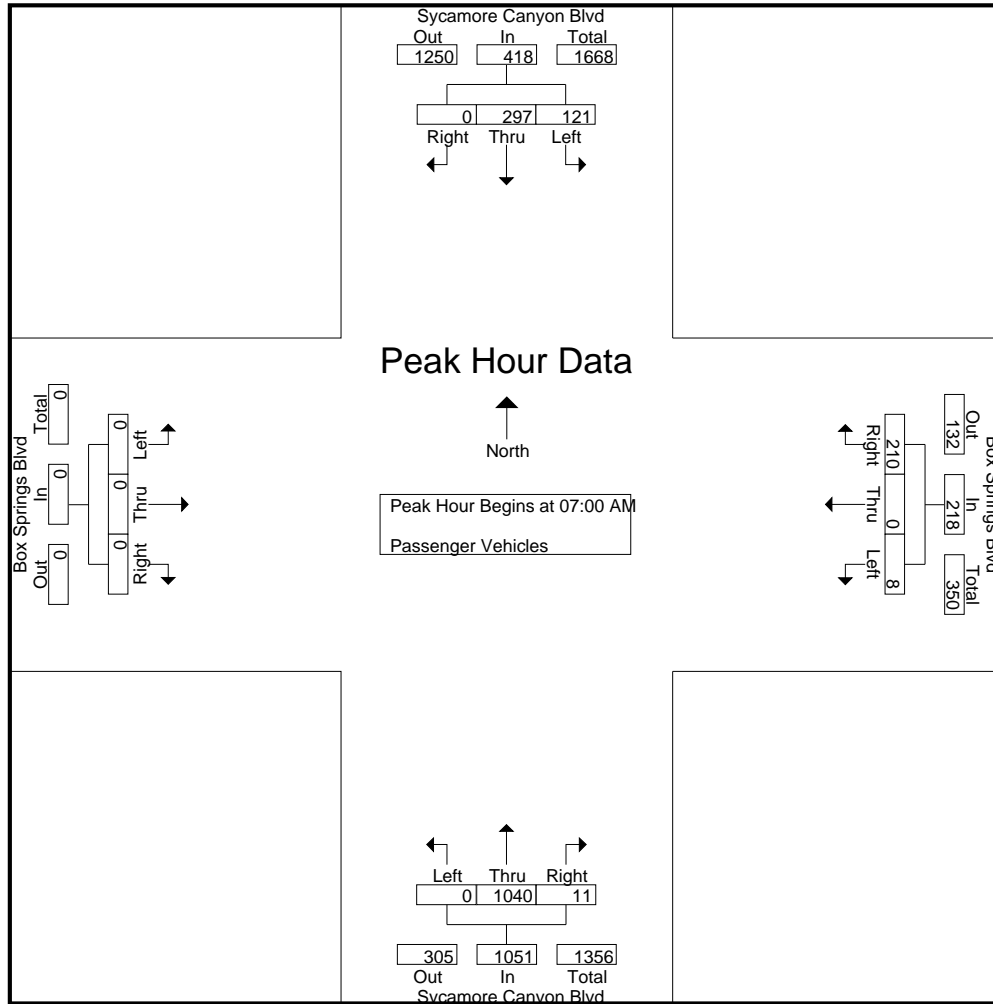

Peak Hour Analysis From 07:00 AM to 07:45 AM - Peak 1 of 1
 Peak Hour for Each Approach Begins at:

	07:00 AM				07:00 AM				07:00 AM				07:00 AM			
+0 mins.	18	61	0	79	2	0	36	38	0	254	2	256	0	0	0	0
+15 mins.	26	62	0	88	3	0	65	68	0	259	1	260	0	0	0	0
+30 mins.	36	75	0	111	1	0	71	72	0	279	3	282	0	0	0	0
+45 mins.	41	99	0	140	2	0	38	40	0	248	5	253	0	0	0	0
Total Volume	121	297	0	418	8	0	210	218	0	1040	11	1051	0	0	0	0
% App. Total	28.9	71.1	0		3.7	0	96.3		0	99	1		0	0	0	
PHF	.738	.750	.000	.746	.667	.000	.739	.757	.000	.932	.550	.932	.000	.000	.000	.000

City of Riverside
 N/S: Sycamore Canyon Blvd
 E/W: Box Springs Blvd
 Weather: Clear

File Name : RIVSCBBAM
 Site Code : 06715392
 Start Date : 7/7/2015
 Page No : 1

Groups Printed- Large 2 Axle Vehicles

Start Time	Sycamore Canyon Blvd Southbound				Box Springs Blvd Westbound				Sycamore Canyon Blvd Northbound				Box Springs Blvd Eastbound				Int. Total
	Left	Thru	Right	App. Total	Left	Thru	Right	App. Total	Left	Thru	Right	App. Total	Left	Thru	Right	App. Total	
07:00 AM	1	1	0	2	0	0	0	0	0	2	1	3	0	0	0	0	5
07:15 AM	0	2	0	2	2	0	1	3	0	3	0	3	0	0	0	0	8
07:30 AM	0	2	0	2	0	0	0	0	0	7	0	7	0	0	0	0	9
07:45 AM	0	2	0	2	0	0	0	0	0	4	0	4	0	0	0	0	6
Total	1	7	0	8	2	0	1	3	0	16	1	17	0	0	0	0	28
08:00 AM	1	0	0	1	0	0	4	4	0	5	1	6	0	0	0	0	11
08:15 AM	0	2	0	2	0	0	2	2	0	3	0	3	0	0	0	0	7
08:30 AM	1	3	0	4	0	0	1	1	0	6	1	7	0	0	0	0	12
08:45 AM	3	1	0	4	0	0	0	0	0	11	0	11	0	0	0	0	15
Total	5	6	0	11	0	0	7	7	0	25	2	27	0	0	0	0	45
Grand Total	6	13	0	19	2	0	8	10	0	41	3	44	0	0	0	0	73
Apprch %	31.6	68.4	0		20	0	80		0	93.2	6.8		0	0	0		
Total %	8.2	17.8	0	26	2.7	0	11	13.7	0	56.2	4.1	60.3	0	0	0	0	

Start Time	Sycamore Canyon Blvd Southbound				Box Springs Blvd Westbound				Sycamore Canyon Blvd Northbound				Box Springs Blvd Eastbound				Int. Total
	Left	Thru	Right	App. Total	Left	Thru	Right	App. Total	Left	Thru	Right	App. Total	Left	Thru	Right	App. Total	
07:00 AM	1	1	0	2	0	0	0	0	0	2	1	3	0	0	0	0	5
07:15 AM	0	2	0	2	2	0	1	3	0	3	0	3	0	0	0	0	8
07:30 AM	0	2	0	2	0	0	0	0	0	7	0	7	0	0	0	0	9
07:45 AM	0	2	0	2	0	0	0	0	0	4	0	4	0	0	0	0	6
Total	1	7	0	8	2	0	1	3	0	16	1	17	0	0	0	0	28
Total Volume % App. Total	12.5	87.5	0		66.7	0	33.3		0	94.1	5.9		0	0	0		
PHF	.250	.875	.000	1.00	.250	.000	.250	.250	.000	.571	.250	.607	.000	.000	.000	.000	.778

Peak Hour Analysis From 07:00 AM to 07:45 AM - Peak 1 of 1

Peak Hour for Entire Intersection Begins at 07:00 AM

City of Riverside
 N/S: Sycamore Canyon Blvd
 E/W: Box Springs Blvd
 Weather: Clear

File Name : RIVSCBBAM
 Site Code : 06715392
 Start Date : 7/7/2015
 Page No : 2

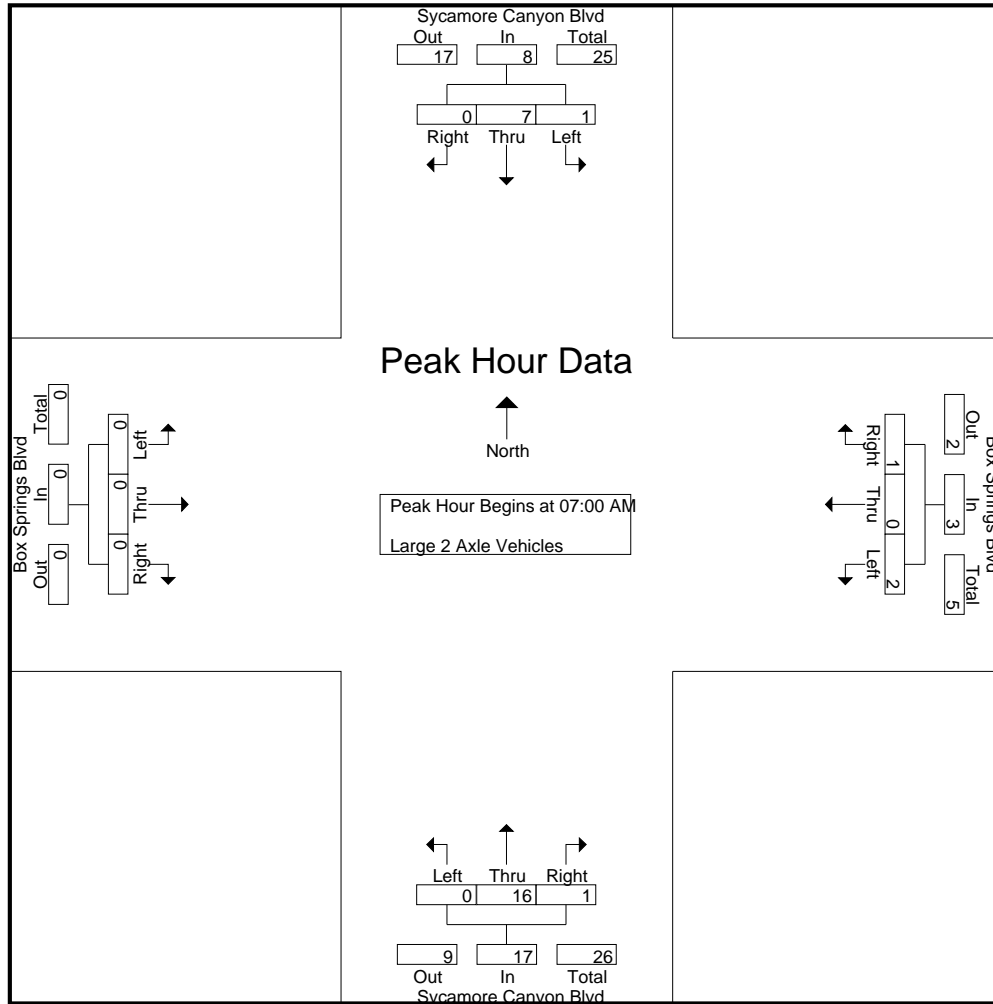

Peak Hour Analysis From 07:00 AM to 07:45 AM - Peak 1 of 1
 Peak Hour for Each Approach Begins at:

	07:00 AM				07:00 AM				07:00 AM				07:00 AM			
+0 mins.	1	1	0	2	0	0	0	0	0	2	1	3	0	0	0	0
+15 mins.	0	2	0	2	2	0	1	3	0	3	0	3	0	0	0	0
+30 mins.	0	2	0	2	0	0	0	0	0	7	0	7	0	0	0	0
+45 mins.	0	2	0	2	0	0	0	0	0	4	0	4	0	0	0	0
Total Volume	1	7	0	8	2	0	1	3	0	16	1	17	0	0	0	0
% App. Total	12.5	87.5	0		66.7	0	33.3		0	94.1	5.9		0	0	0	
PHF	.250	.875	.000	1.000	.250	.000	.250	.250	.000	.571	.250	.607	.000	.000	.000	.000

City of Riverside
 N/S: Sycamore Canyon Blvd
 E/W: Box Springs Blvd
 Weather: Clear

File Name : RIVSCBBAM
 Site Code : 06715392
 Start Date : 7/7/2015
 Page No : 1

Groups Printed- 3 Axle Vehicles

Start Time	Sycamore Canyon Blvd Southbound				Box Springs Blvd Westbound				Sycamore Canyon Blvd Northbound				Box Springs Blvd Eastbound				Int. Total
	Left	Thru	Right	App. Total	Left	Thru	Right	App. Total	Left	Thru	Right	App. Total	Left	Thru	Right	App. Total	
07:00 AM	0	1	0	1	0	0	0	0	0	1	0	1	0	0	0	0	2
07:15 AM	1	1	0	2	0	0	0	0	0	1	0	1	0	0	0	0	3
07:30 AM	1	0	0	1	0	0	2	2	0	0	0	0	0	0	0	0	3
07:45 AM	0	0	0	0	1	0	1	2	0	4	1	5	0	0	0	0	7
Total	2	2	0	4	1	0	3	4	0	6	1	7	0	0	0	0	15
08:00 AM	0	0	0	0	0	0	0	0	0	0	0	0	0	0	0	0	0
08:15 AM	0	0	0	0	0	0	0	0	0	3	0	3	0	0	0	0	3
08:30 AM	0	0	0	0	0	0	0	0	0	1	0	1	0	0	0	0	1
08:45 AM	0	0	0	0	1	0	2	3	0	2	1	3	0	0	0	0	6
Total	0	0	0	0	1	0	2	3	0	6	1	7	0	0	0	0	10
Grand Total	2	2	0	4	2	0	5	7	0	12	2	14	0	0	0	0	25
Apprch %	50	50	0		28.6	0	71.4		0	85.7	14.3		0	0	0		
Total %	8	8	0	16	8	0	20	28	0	48	8	56	0	0	0	0	

Start Time	Sycamore Canyon Blvd Southbound				Box Springs Blvd Westbound				Sycamore Canyon Blvd Northbound				Box Springs Blvd Eastbound				Int. Total
	Left	Thru	Right	App. Total	Left	Thru	Right	App. Total	Left	Thru	Right	App. Total	Left	Thru	Right	App. Total	
07:00 AM	0	1	0	1	0	0	0	0	0	1	0	1	0	0	0	0	2
07:15 AM	1	1	0	2	0	0	0	0	0	1	0	1	0	0	0	0	3
07:30 AM	1	0	0	1	0	0	2	2	0	0	0	0	0	0	0	0	3
07:45 AM	0	0	0	0	1	0	1	2	0	4	1	5	0	0	0	0	7
Total	2	2	0	4	1	0	3	4	0	6	1	7	0	0	0	0	15
Total Volume % App. Total	50	50	0		25	0	75		0	85.7	14.3		0	0	0		
PHF	.500	.500	.000	.500	.250	.000	.375	.500	.000	.375	.250	.350	.000	.000	.000	.000	.536

Peak Hour Analysis From 07:00 AM to 07:45 AM - Peak 1 of 1

Peak Hour for Entire Intersection Begins at 07:00 AM

City of Riverside
 N/S: Sycamore Canyon Blvd
 E/W: Box Springs Blvd
 Weather: Clear

File Name : RIVSCBBAM
 Site Code : 06715392
 Start Date : 7/7/2015
 Page No : 2

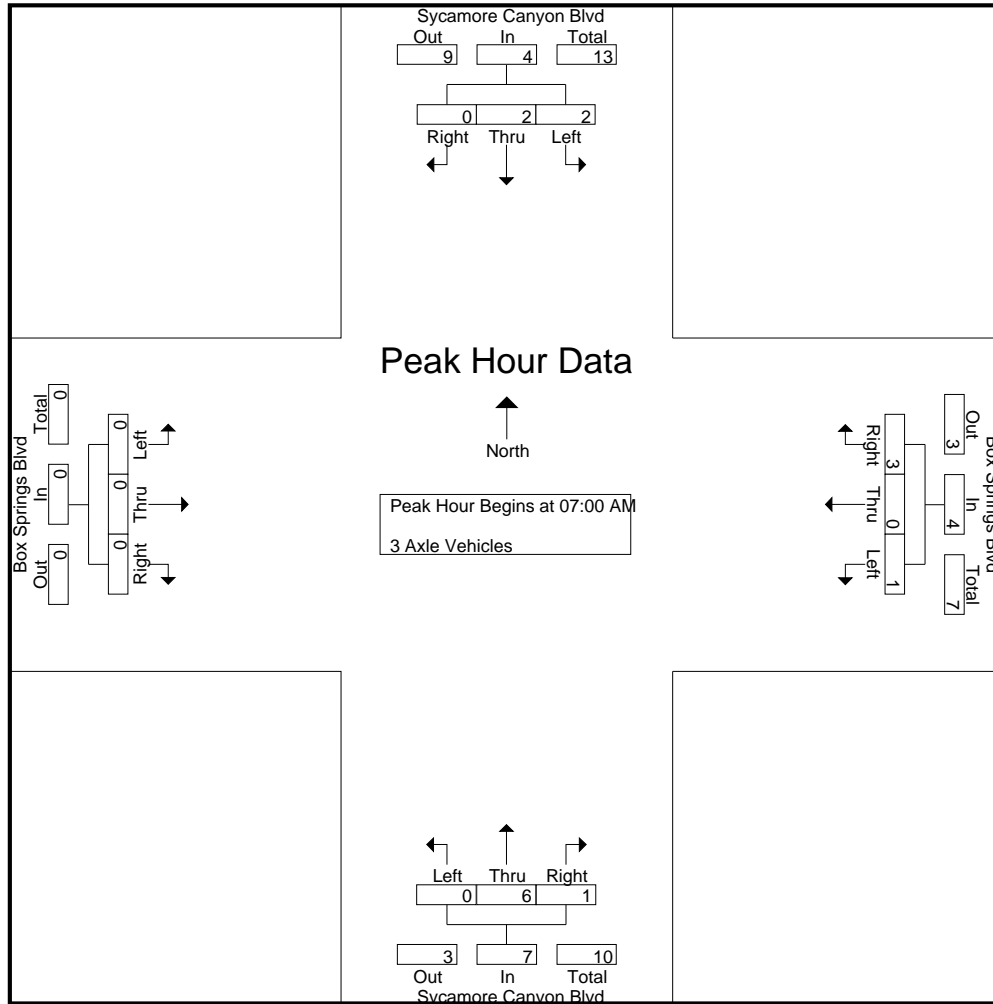

Peak Hour Analysis From 07:00 AM to 07:45 AM - Peak 1 of 1
 Peak Hour for Each Approach Begins at:

	07:00 AM				07:00 AM				07:00 AM				07:00 AM			
+0 mins.	0	1	0	1	0	0	0	0	0	1	0	1	0	0	0	0
+15 mins.	1	1	0	2	0	0	0	0	0	1	0	1	0	0	0	0
+30 mins.	1	0	0	1	0	0	2	2	0	0	0	0	0	0	0	0
+45 mins.	0	0	0	0	1	0	1	2	0	4	1	5	0	0	0	0
Total Volume	2	2	0	4	1	0	3	4	0	6	1	7	0	0	0	0
% App. Total	50	50	0		25	0	75		0	85.7	14.3		0	0	0	
PHF	.500	.500	.000	.500	.250	.000	.375	.500	.000	.375	.250	.350	.000	.000	.000	.000

City of Riverside
 N/S: Sycamore Canyon Blvd
 E/W: Box Springs Blvd
 Weather: Clear

File Name : RIVSCBBAM
 Site Code : 06715392
 Start Date : 7/7/2015
 Page No : 1

Groups Printed- 4+ Axle Trucks

Start Time	Sycamore Canyon Blvd Southbound				Box Springs Blvd Westbound				Sycamore Canyon Blvd Northbound				Box Springs Blvd Eastbound				Int. Total
	Left	Thru	Right	App. Total	Left	Thru	Right	App. Total	Left	Thru	Right	App. Total	Left	Thru	Right	App. Total	
07:00 AM	0	1	0	1	1	0	1	2	0	9	1	10	0	0	0	0	13
07:15 AM	0	3	0	3	0	0	0	0	0	8	0	8	0	0	0	0	11
07:30 AM	1	1	0	2	1	0	0	1	0	13	1	14	0	0	0	0	17
07:45 AM	0	0	0	0	0	0	1	1	0	9	3	12	0	0	0	0	13
Total	1	5	0	6	2	0	2	4	0	39	5	44	0	0	0	0	54
08:00 AM	0	2	0	2	0	0	2	2	0	13	2	15	0	0	0	0	19
08:15 AM	0	1	0	1	0	0	1	1	0	12	0	12	0	0	0	0	14
08:30 AM	0	1	0	1	0	0	0	0	0	12	1	13	0	0	0	0	14
08:45 AM	2	2	0	4	0	0	0	0	0	6	0	6	0	0	0	0	10
Total	2	6	0	8	0	0	3	3	0	43	3	46	0	0	0	0	57
Grand Total	3	11	0	14	2	0	5	7	0	82	8	90	0	0	0	0	111
Apprch %	21.4	78.6	0		28.6	0	71.4		0	91.1	8.9		0	0	0		
Total %	2.7	9.9	0	12.6	1.8	0	4.5	6.3	0	73.9	7.2	81.1	0	0	0	0	

Start Time	Sycamore Canyon Blvd Southbound				Box Springs Blvd Westbound				Sycamore Canyon Blvd Northbound				Box Springs Blvd Eastbound				Int. Total
	Left	Thru	Right	App. Total	Left	Thru	Right	App. Total	Left	Thru	Right	App. Total	Left	Thru	Right	App. Total	
07:00 AM	0	1	0	1	1	0	1	2	0	9	1	10	0	0	0	0	13
07:15 AM	0	3	0	3	0	0	0	0	0	8	0	8	0	0	0	0	11
07:30 AM	1	1	0	2	1	0	0	1	0	13	1	14	0	0	0	0	17
07:45 AM	0	0	0	0	0	0	1	1	0	9	3	12	0	0	0	0	13
Total	1	5	0	6	2	0	2	4	0	39	5	44	0	0	0	0	54
Total Volume																	
% App. Total	16.7	83.3	0		50	0	50		0	88.6	11.4		0	0	0		
PHF	.250	.417	.000	.500	.500	.000	.500	.500	.000	.750	.417	.786	.000	.000	.000	.000	.794

Peak Hour Analysis From 07:00 AM to 07:45 AM - Peak 1 of 1

Peak Hour for Entire Intersection Begins at 07:00 AM

City of Riverside
 N/S: Sycamore Canyon Blvd
 E/W: Box Springs Blvd
 Weather: Clear

File Name : RIVSCBBAM
 Site Code : 06715392
 Start Date : 7/7/2015
 Page No : 2

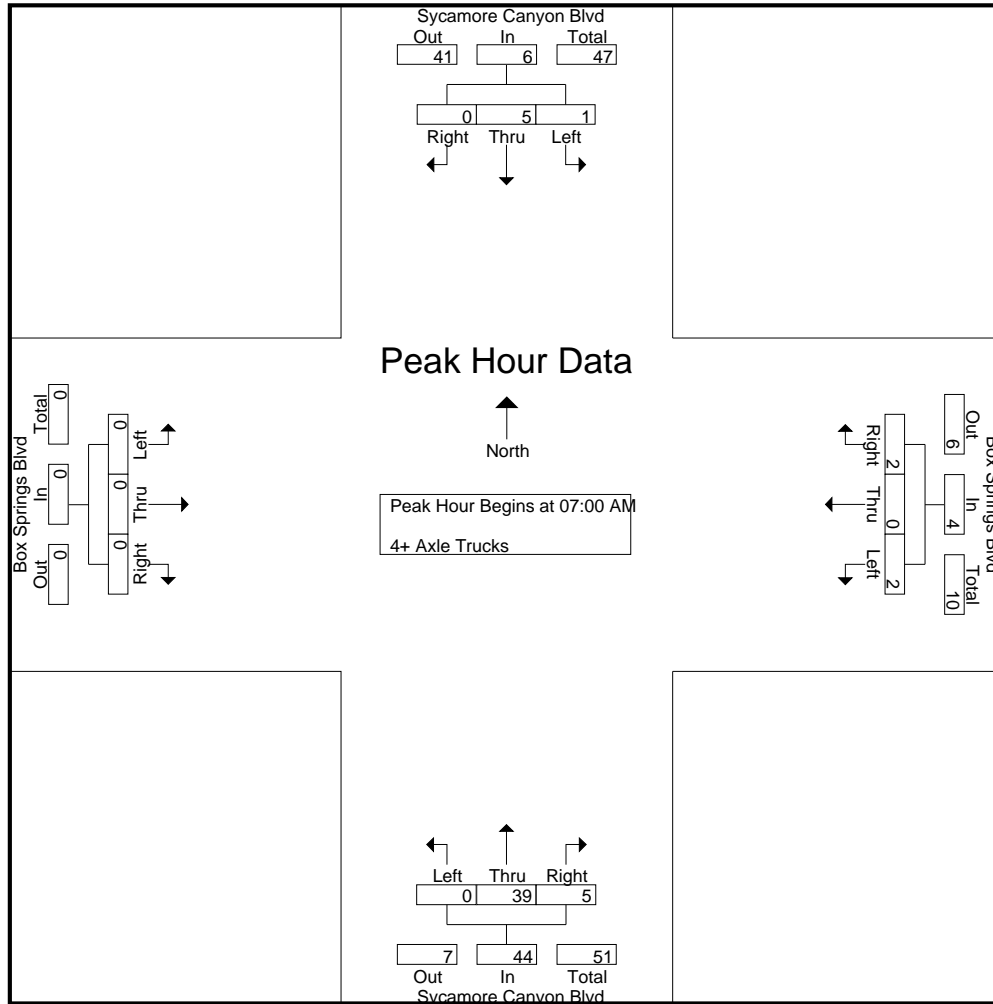

Peak Hour Analysis From 07:00 AM to 07:45 AM - Peak 1 of 1
 Peak Hour for Each Approach Begins at:

	07:00 AM				07:00 AM				07:00 AM				07:00 AM			
+0 mins.	0	1	0	1	1	0	1	2	0	9	1	10	0	0	0	0
+15 mins.	0	3	0	3	0	0	0	0	0	8	0	8	0	0	0	0
+30 mins.	1	1	0	2	1	0	0	1	0	13	1	14	0	0	0	0
+45 mins.	0	0	0	0	0	0	1	1	0	9	3	12	0	0	0	0
Total Volume	1	5	0	6	2	0	2	4	0	39	5	44	0	0	0	0
% App. Total	16.7	83.3	0		50	0	50		0	88.6	11.4		0	0	0	
PHF	.250	.417	.000	.500	.500	.000	.500	.500	.000	.750	.417	.786	.000	.000	.000	.000

City of Riverside
 N/S: Sycamore Canyon Blvd
 E/W: Box Springs Blvd
 Weather: Clear

File Name : RIVSCBBPM
 Site Code : 06715392
 Start Date : 7/7/2015
 Page No : 1

Groups Printed- Passenger Vehicles - Large 2 Axle Vehicles - 3 Axle Vehicles - 4+ Axle Trucks

Start Time	Sycamore Canyon Blvd Southbound				Box Springs Blvd Westbound				Sycamore Canyon Blvd Northbound				Box Springs Blvd Eastbound				Int. Total
	Left	Thru	Right	App. Total	Left	Thru	Right	App. Total	Left	Thru	Right	App. Total	Left	Thru	Right	App. Total	
04:00 PM	14	110	0	124	2	0	49	51	0	133	1	134	15	1	7	23	332
04:15 PM	9	67	0	76	2	0	30	32	0	104	6	110	5	0	3	8	226
04:30 PM	8	80	0	88	3	0	53	56	0	118	4	122	28	1	10	39	305
04:45 PM	19	87	0	106	2	0	40	42	0	94	0	94	6	0	0	6	248
Total	50	344	0	394	9	0	172	181	0	449	11	460	54	2	20	76	1111
05:00 PM	7	98	0	105	5	0	84	89	0	147	0	147	7	0	4	11	352
05:15 PM	9	108	0	117	0	0	38	38	1	127	1	129	0	0	1	1	285
05:30 PM	4	85	0	89	3	0	18	21	0	89	2	91	2	0	2	4	205
05:45 PM	11	90	0	101	1	0	28	29	0	81	0	81	0	0	0	0	211
Total	31	381	0	412	9	0	168	177	1	444	3	448	9	0	7	16	1053
Grand Total	81	725	0	806	18	0	340	358	1	893	14	908	63	2	27	92	2164
Apprch %	10	90	0		5	0	95		0.1	98.3	1.5		68.5	2.2	29.3		
Total %	3.7	33.5	0	37.2	0.8	0	15.7	16.5	0	41.3	0.6	42	2.9	0.1	1.2	4.3	
Passenger Vehicles	69	691	0	760	13	0	326	339	1	840	12	853	63	2	27	92	2044
% Passenger Vehicles	85.2	95.3	0	94.3	72.2	0	95.9	94.7	100	94.1	85.7	93.9	100	100	100	100	94.5
Large 2 Axle Vehicles	10	13	0	23	2	0	4	6	0	16	0	16	0	0	0	0	45
% Large 2 Axle Vehicles	12.3	1.8	0	2.9	11.1	0	1.2	1.7	0	1.8	0	1.8	0	0	0	0	2.1
3 Axle Vehicles	1	2	0	3	0	0	3	3	0	8	0	8	0	0	0	0	14
% 3 Axle Vehicles	1.2	0.3	0	0.4	0	0	0.9	0.8	0	0.9	0	0.9	0	0	0	0	0.6
4+ Axle Trucks	1	19	0	20	3	0	7	10	0	29	2	31	0	0	0	0	61
% 4+ Axle Trucks	1.2	2.6	0	2.5	16.7	0	2.1	2.8	0	3.2	14.3	3.4	0	0	0	0	2.8

Start Time	Sycamore Canyon Blvd Southbound				Box Springs Blvd Westbound				Sycamore Canyon Blvd Northbound				Box Springs Blvd Eastbound				Int. Total
	Left	Thru	Right	App. Total	Left	Thru	Right	App. Total	Left	Thru	Right	App. Total	Left	Thru	Right	App. Total	
04:30 PM	8	80	0	88	3	0	53	56	0	118	4	122	28	1	10	39	305
04:45 PM	19	87	0	106	2	0	40	42	0	94	0	94	6	0	0	6	248
05:00 PM	7	98	0	105	5	0	84	89	0	147	0	147	7	0	4	11	352
05:15 PM	9	108	0	117	0	0	38	38	1	127	1	129	0	0	1	1	285
Total Volume	43	373	0	416	10	0	215	225	1	486	5	492	41	1	15	57	1190
% App. Total	10.3	89.7	0		4.4	0	95.6		0.2	98.8	1		71.9	1.8	26.3		
PHF	.566	.863	.000	.889	.500	.000	.640	.632	.250	.827	.313	.837	.366	.250	.375	.365	.845

Peak Hour Analysis From 04:00 PM to 05:45 PM - Peak 1 of 1
 Peak Hour for Entire Intersection Begins at 04:30 PM

City of Riverside
 N/S: Sycamore Canyon Blvd
 E/W: Box Springs Blvd
 Weather: Clear

File Name : RIVSCBBPM
 Site Code : 06715392
 Start Date : 7/7/2015
 Page No : 2

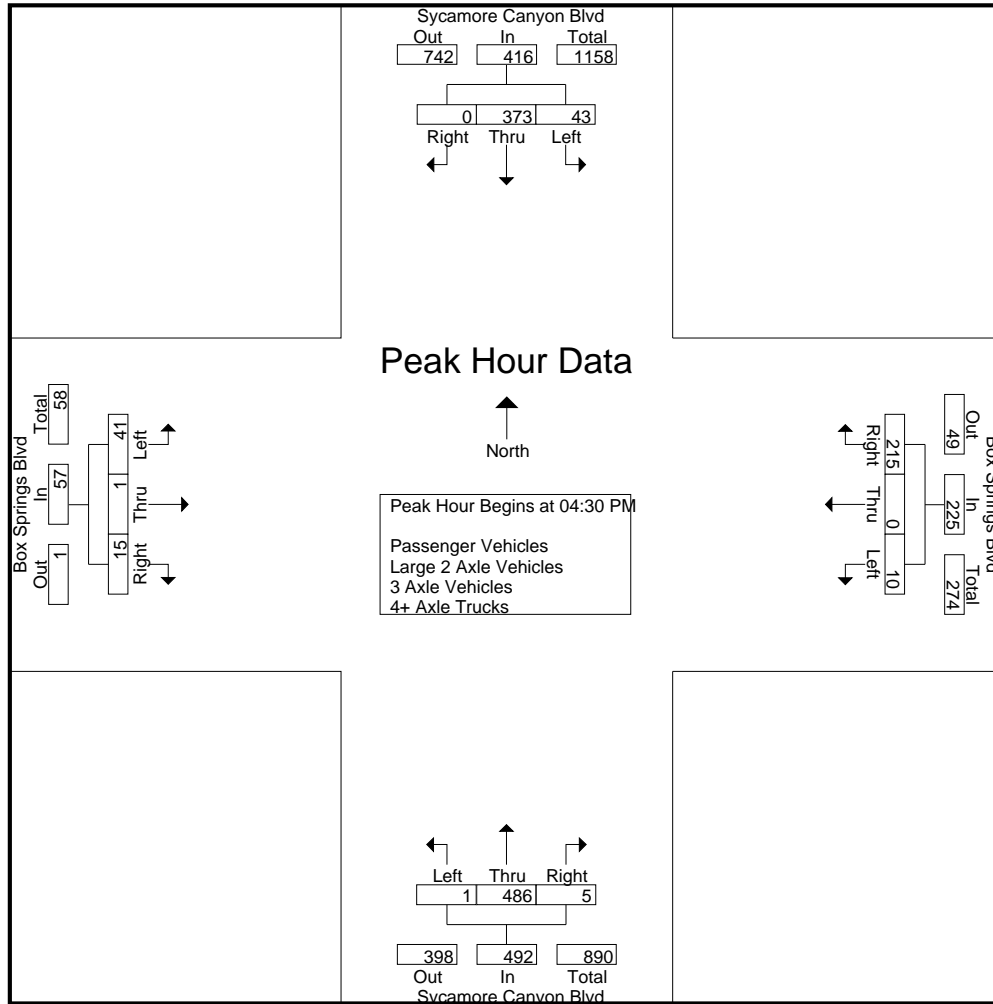

Peak Hour Analysis From 04:00 PM to 05:45 PM - Peak 1 of 1
 Peak Hour for Each Approach Begins at:

	04:45 PM				04:30 PM				04:30 PM				04:00 PM			
+0 mins.	19	87	0	106	3	0	53	56	0	118	4	122	15	1	7	23
+15 mins.	7	98	0	105	2	0	40	42	0	94	0	94	5	0	3	8
+30 mins.	9	108	0	117	5	0	84	89	0	147	0	147	28	1	10	39
+45 mins.	4	85	0	89	0	0	38	38	1	127	1	129	6	0	0	6
Total Volume	39	378	0	417	10	0	215	225	1	486	5	492	54	2	20	76
% App. Total	9.4	90.6	0		4.4	0	95.6		0.2	98.8	1		71.1	2.6	26.3	
PHF	.513	.875	.000	.891	.500	.000	.640	.632	.250	.827	.313	.837	.482	.500	.500	.487

City of Riverside
 N/S: Sycamore Canyon Blvd
 E/W: Box Springs Blvd
 Weather: Clear

File Name : RIVSCBBPM
 Site Code : 06715392
 Start Date : 7/7/2015
 Page No : 1

Groups Printed- Passenger Vehicles

Start Time	Sycamore Canyon Blvd Southbound				Box Springs Blvd Westbound				Sycamore Canyon Blvd Northbound				Box Springs Blvd Eastbound				Int. Total
	Left	Thru	Right	App. Total	Left	Thru	Right	App. Total	Left	Thru	Right	App. Total	Left	Thru	Right	App. Total	
04:00 PM	13	102	0	115	2	0	48	50	0	121	1	122	15	1	7	23	310
04:15 PM	7	64	0	71	2	0	29	31	0	99	5	104	5	0	3	8	214
04:30 PM	7	75	0	82	2	0	52	54	0	112	4	116	28	1	10	39	291
04:45 PM	16	83	0	99	1	0	38	39	0	90	0	90	6	0	0	6	234
Total	43	324	0	367	7	0	167	174	0	422	10	432	54	2	20	76	1049
05:00 PM	5	95	0	100	4	0	80	84	0	142	0	142	7	0	4	11	337
05:15 PM	8	102	0	110	0	0	37	37	1	118	0	119	0	0	1	1	267
05:30 PM	4	83	0	87	1	0	17	18	0	82	2	84	2	0	2	4	193
05:45 PM	9	87	0	96	1	0	25	26	0	76	0	76	0	0	0	0	198
Total	26	367	0	393	6	0	159	165	1	418	2	421	9	0	7	16	995
Grand Total	69	691	0	760	13	0	326	339	1	840	12	853	63	2	27	92	2044
Apprch %	9.1	90.9	0		3.8	0	96.2		0.1	98.5	1.4		68.5	2.2	29.3		
Total %	3.4	33.8	0	37.2	0.6	0	15.9	16.6	0	41.1	0.6	41.7	3.1	0.1	1.3	4.5	

Start Time	Sycamore Canyon Blvd Southbound				Box Springs Blvd Westbound				Sycamore Canyon Blvd Northbound				Box Springs Blvd Eastbound				Int. Total
	Left	Thru	Right	App. Total	Left	Thru	Right	App. Total	Left	Thru	Right	App. Total	Left	Thru	Right	App. Total	
04:30 PM	7	75	0	82	2	0	52	54	0	112	4	116	28	1	10	39	291
04:45 PM	16	83	0	99	1	0	38	39	0	90	0	90	6	0	0	6	234
05:00 PM	5	95	0	100	4	0	80	84	0	142	0	142	7	0	4	11	337
05:15 PM	8	102	0	110	0	0	37	37	1	118	0	119	0	0	1	1	267
Total Volume	36	355	0	391	7	0	207	214	1	462	4	467	41	1	15	57	1129
% App. Total	9.2	90.8	0		3.3	0	96.7		0.2	98.9	0.9		71.9	1.8	26.3		
PHF	.563	.870	.000	.889	.438	.000	.647	.637	.250	.813	.250	.822	.366	.250	.375	.365	.838

Peak Hour Analysis From 04:30 PM to 05:15 PM - Peak 1 of 1

Peak Hour for Entire Intersection Begins at 04:30 PM

City of Riverside
 N/S: Sycamore Canyon Blvd
 E/W: Box Springs Blvd
 Weather: Clear

File Name : RIVSCBBPM
 Site Code : 06715392
 Start Date : 7/7/2015
 Page No : 2

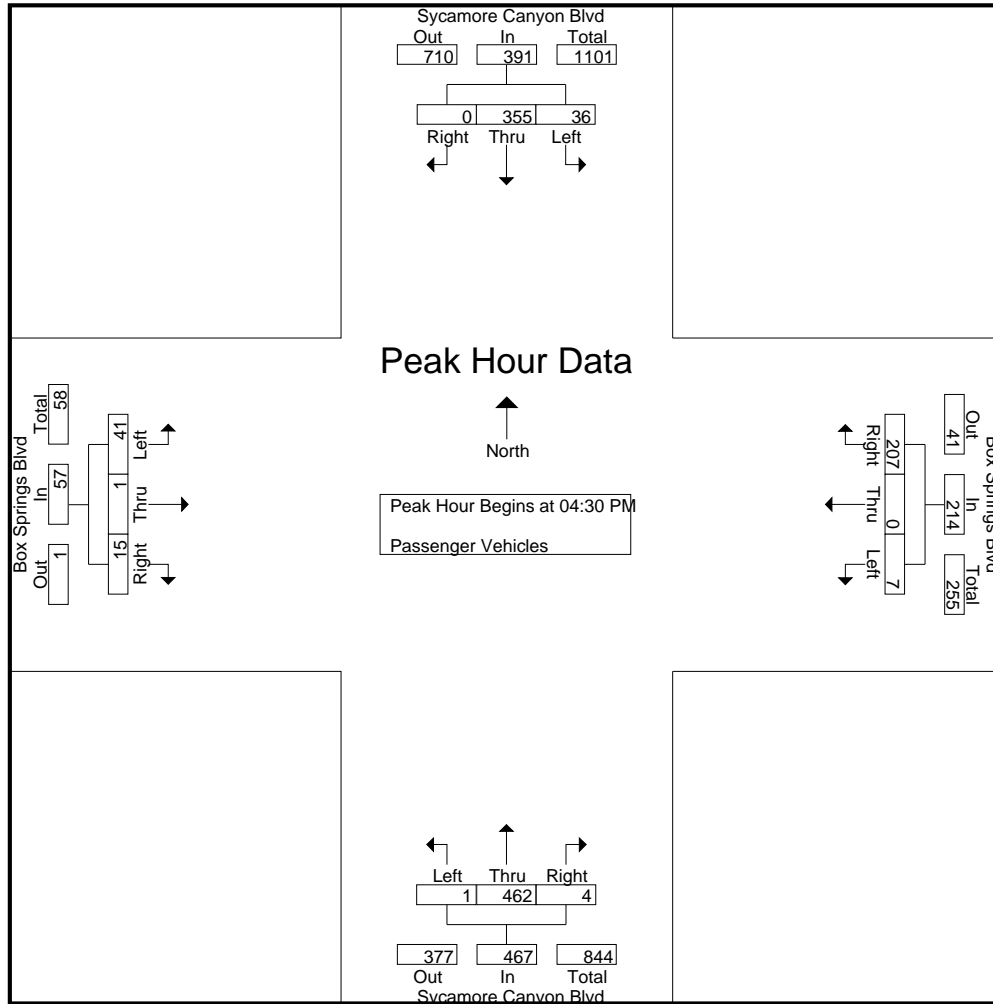

Peak Hour Analysis From 04:30 PM to 05:15 PM - Peak 1 of 1
 Peak Hour for Each Approach Begins at:

	04:30 PM				04:30 PM				04:30 PM				04:30 PM			
+0 mins.	7	75	0	82	2	0	52	54	0	112	4	116	28	1	10	39
+15 mins.	16	83	0	99	1	0	38	39	0	90	0	90	6	0	0	6
+30 mins.	5	95	0	100	4	0	80	84	0	142	0	142	7	0	4	11
+45 mins.	8	102	0	110	0	0	37	37	1	118	0	119	0	0	1	1
Total Volume	36	355	0	391	7	0	207	214	1	462	4	467	41	1	15	57
% App. Total	9.2	90.8	0		3.3	0	96.7		0.2	98.9	0.9		71.9	1.8	26.3	
PHF	.563	.870	.000	.889	.438	.000	.647	.637	.250	.813	.250	.822	.366	.250	.375	.365

City of Riverside
 N/S: Sycamore Canyon Blvd
 E/W: Box Springs Blvd
 Weather: Clear

File Name : RIVSCBBPM
 Site Code : 06715392
 Start Date : 7/7/2015
 Page No : 1

Groups Printed- Large 2 Axle Vehicles

Start Time	Sycamore Canyon Blvd Southbound				Box Springs Blvd Westbound				Sycamore Canyon Blvd Northbound				Box Springs Blvd Eastbound				Int. Total
	Left	Thru	Right	App. Total	Left	Thru	Right	App. Total	Left	Thru	Right	App. Total	Left	Thru	Right	App. Total	
04:00 PM	1	4	0	5	0	0	1	1	0	3	0	3	0	0	0	0	9
04:15 PM	2	0	0	2	0	0	0	0	0	0	0	0	0	0	0	0	2
04:30 PM	0	1	0	1	0	0	1	1	0	1	0	1	0	0	0	0	3
04:45 PM	3	2	0	5	0	0	0	0	0	3	0	3	0	0	0	0	8
Total	6	7	0	13	0	0	2	2	0	7	0	7	0	0	0	0	22
05:00 PM	1	0	0	1	0	0	2	2	0	0	0	0	0	0	0	0	3
05:15 PM	1	4	0	5	0	0	0	0	0	2	0	2	0	0	0	0	7
05:30 PM	0	0	0	0	2	0	0	2	0	4	0	4	0	0	0	0	6
05:45 PM	2	2	0	4	0	0	0	0	0	3	0	3	0	0	0	0	7
Total	4	6	0	10	2	0	2	4	0	9	0	9	0	0	0	0	23
Grand Total	10	13	0	23	2	0	4	6	0	16	0	16	0	0	0	0	45
Apprch %	43.5	56.5	0		33.3	0	66.7		0	100	0		0	0	0		
Total %	22.2	28.9	0	51.1	4.4	0	8.9	13.3	0	35.6	0	35.6	0	0	0	0	

Start Time	Sycamore Canyon Blvd Southbound				Box Springs Blvd Westbound				Sycamore Canyon Blvd Northbound				Box Springs Blvd Eastbound				Int. Total
	Left	Thru	Right	App. Total	Left	Thru	Right	App. Total	Left	Thru	Right	App. Total	Left	Thru	Right	App. Total	
04:30 PM	0	1	0	1	0	0	1	1	0	1	0	1	0	0	0	0	3
04:45 PM	3	2	0	5	0	0	0	0	0	3	0	3	0	0	0	0	8
05:00 PM	1	0	0	1	0	0	2	2	0	0	0	0	0	0	0	0	3
05:15 PM	1	4	0	5	0	0	0	0	0	2	0	2	0	0	0	0	7
Total Volume	5	7	0	12	0	0	3	3	0	6	0	6	0	0	0	0	21
% App. Total	41.7	58.3	0		0	0	100		0	100	0		0	0	0		
PHF	.417	.438	.000	.600	.000	.000	.375	.375	.000	.500	.000	.500	.000	.000	.000	.000	.656

Peak Hour Analysis From 04:30 PM to 05:15 PM - Peak 1 of 1

Peak Hour for Entire Intersection Begins at 04:30 PM

City of Riverside
 N/S: Sycamore Canyon Blvd
 E/W: Box Springs Blvd
 Weather: Clear

File Name : RIVSCBBPM
 Site Code : 06715392
 Start Date : 7/7/2015
 Page No : 2

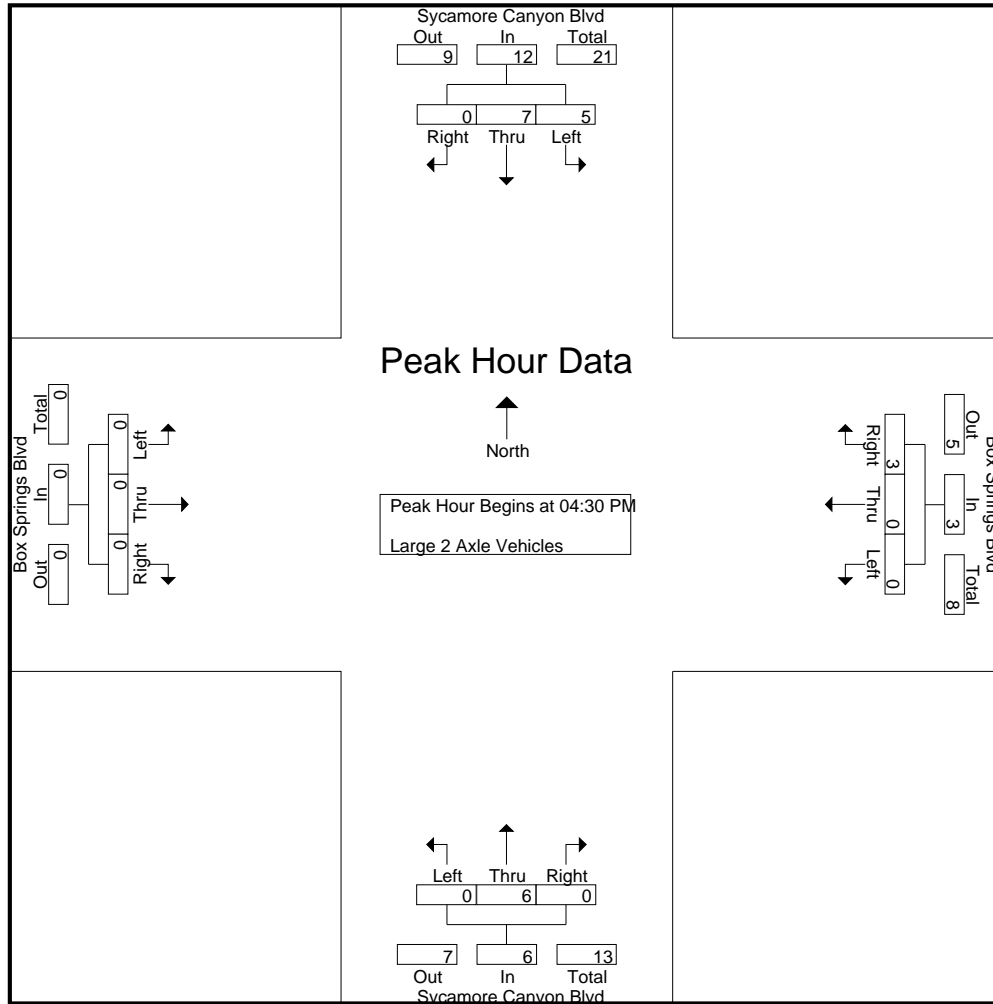

Peak Hour Analysis From 04:30 PM to 05:15 PM - Peak 1 of 1
 Peak Hour for Each Approach Begins at:

	04:30 PM				04:30 PM				04:30 PM				04:30 PM			
+0 mins.	0	1	0	1	0	0	1	1	0	1	0	1	0	0	0	0
+15 mins.	3	2	0	5	0	0	0	0	0	3	0	3	0	0	0	0
+30 mins.	1	0	0	1	0	0	2	2	0	0	0	0	0	0	0	0
+45 mins.	1	4	0	5	0	0	0	0	0	2	0	2	0	0	0	0
Total Volume	5	7	0	12	0	0	3	3	0	6	0	6	0	0	0	0
% App. Total	41.7	58.3	0		0	0	100		0	100	0		0	0	0	
PHF	.417	.438	.000	.600	.000	.000	.375	.375	.000	.500	.000	.500	.000	.000	.000	.000

City of Riverside
 N/S: Sycamore Canyon Blvd
 E/W: Box Springs Blvd
 Weather: Clear

File Name : RIVSCBBPM
 Site Code : 06715392
 Start Date : 7/7/2015
 Page No : 1

Groups Printed- 3 Axle Vehicles

Start Time	Sycamore Canyon Blvd Southbound				Box Springs Blvd Westbound				Sycamore Canyon Blvd Northbound				Box Springs Blvd Eastbound				Int. Total
	Left	Thru	Right	App. Total	Left	Thru	Right	App. Total	Left	Thru	Right	App. Total	Left	Thru	Right	App. Total	
04:00 PM	0	0	0	0	0	0	0	0	0	3	0	3	0	0	0	0	3
04:15 PM	0	0	0	0	0	0	0	0	0	0	0	0	0	0	0	0	0
04:30 PM	1	1	0	2	0	0	0	0	0	2	0	2	0	0	0	0	4
04:45 PM	0	0	0	0	0	0	1	1	0	0	0	0	0	0	0	0	1
Total	1	1	0	2	0	0	1	1	0	5	0	5	0	0	0	0	8
05:00 PM	0	1	0	1	0	0	0	0	0	2	0	2	0	0	0	0	3
05:15 PM	0	0	0	0	0	0	0	0	0	0	0	0	0	0	0	0	0
05:30 PM	0	0	0	0	0	0	0	0	0	0	0	0	0	0	0	0	0
05:45 PM	0	0	0	0	0	0	2	2	0	1	0	1	0	0	0	0	3
Total	0	1	0	1	0	0	2	2	0	3	0	3	0	0	0	0	6
Grand Total	1	2	0	3	0	0	3	3	0	8	0	8	0	0	0	0	14
Apprch %	33.3	66.7	0		0	0	100		0	100	0		0	0	0		
Total %	7.1	14.3	0	21.4	0	0	21.4	21.4	0	57.1	0	57.1	0	0	0	0	

Start Time	Sycamore Canyon Blvd Southbound				Box Springs Blvd Westbound				Sycamore Canyon Blvd Northbound				Box Springs Blvd Eastbound				Int. Total
	Left	Thru	Right	App. Total	Left	Thru	Right	App. Total	Left	Thru	Right	App. Total	Left	Thru	Right	App. Total	
04:30 PM	1	1	0	2	0	0	0	0	0	2	0	2	0	0	0	0	4
04:45 PM	0	0	0	0	0	0	1	1	0	0	0	0	0	0	0	0	1
05:00 PM	0	1	0	1	0	0	0	0	0	2	0	2	0	0	0	0	3
05:15 PM	0	0	0	0	0	0	0	0	0	0	0	0	0	0	0	0	0
Total Volume	1	2	0	3	0	0	1	1	0	4	0	4	0	0	0	0	8
% App. Total	33.3	66.7	0		0	0	100		0	100	0		0	0	0		
PHF	.250	.500	.000	.375	.000	.000	.250	.250	.000	.500	.000	.500	.000	.000	.000	.000	.500

Peak Hour Analysis From 04:30 PM to 05:15 PM - Peak 1 of 1

Peak Hour for Entire Intersection Begins at 04:30 PM

City of Riverside
 N/S: Sycamore Canyon Blvd
 E/W: Box Springs Blvd
 Weather: Clear

File Name : RIVSCBBPM
 Site Code : 06715392
 Start Date : 7/7/2015
 Page No : 2

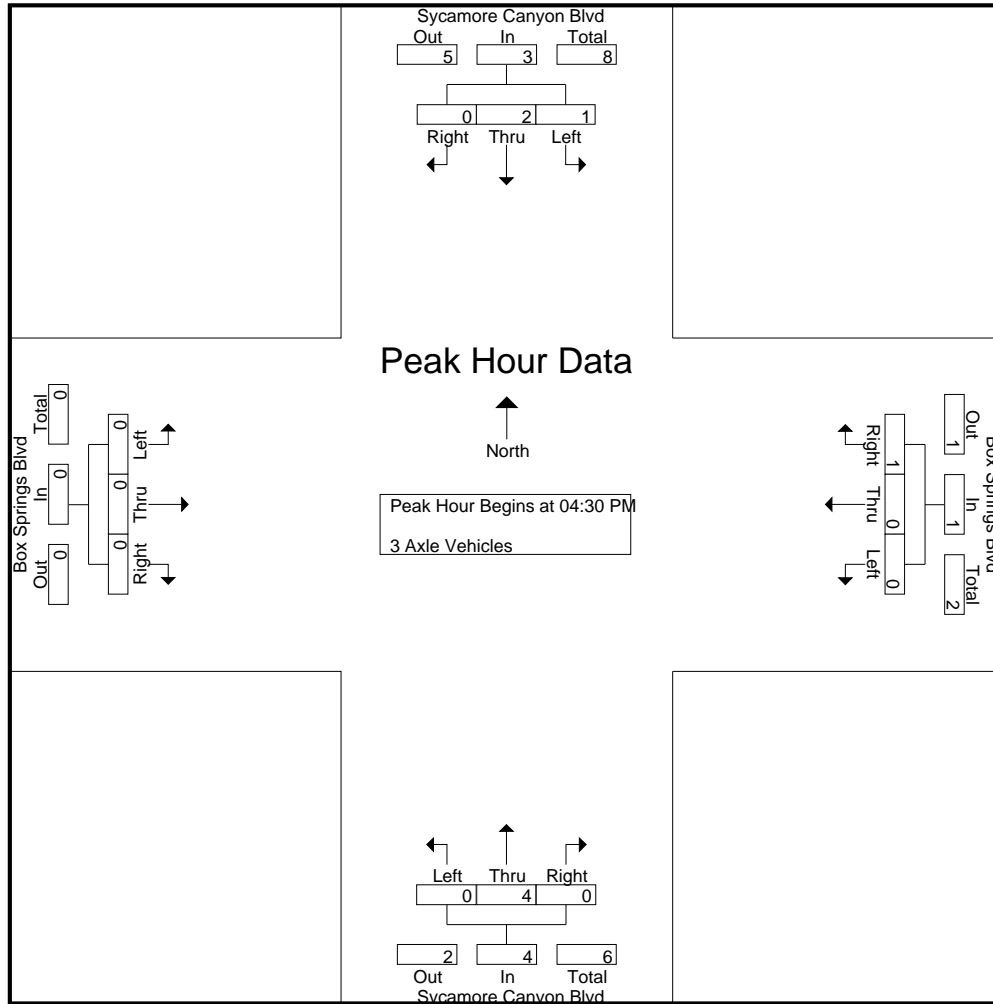

Peak Hour Analysis From 04:30 PM to 05:15 PM - Peak 1 of 1
 Peak Hour for Each Approach Begins at:

	04:30 PM				04:30 PM				04:30 PM				04:30 PM			
+0 mins.	1	1	0	2	0	0	0	0	0	2	0	2	0	0	0	0
+15 mins.	0	0	0	0	0	0	1	1	0	0	0	0	0	0	0	0
+30 mins.	0	1	0	1	0	0	0	0	0	2	0	2	0	0	0	0
+45 mins.	0	0	0	0	0	0	0	0	0	0	0	0	0	0	0	0
Total Volume	1	2	0	3	0	0	1	1	0	4	0	4	0	0	0	0
% App. Total	33.3	66.7	0		0	0	100		0	100	0		0	0	0	
PHF	.250	.500	.000	.375	.000	.000	.250	.250	.000	.500	.000	.500	.000	.000	.000	.000

City of Riverside
 N/S: Sycamore Canyon Blvd
 E/W: Box Springs Blvd
 Weather: Clear

File Name : RIVSCBBPM
 Site Code : 06715392
 Start Date : 7/7/2015
 Page No : 1

Groups Printed- 4+ Axle Trucks

Start Time	Sycamore Canyon Blvd Southbound				Box Springs Blvd Westbound				Sycamore Canyon Blvd Northbound				Box Springs Blvd Eastbound				Int. Total
	Left	Thru	Right	App. Total	Left	Thru	Right	App. Total	Left	Thru	Right	App. Total	Left	Thru	Right	App. Total	
04:00 PM	0	4	0	4	0	0	0	0	0	6	0	6	0	0	0	0	10
04:15 PM	0	3	0	3	0	0	1	1	0	5	1	6	0	0	0	0	10
04:30 PM	0	3	0	3	1	0	0	1	0	3	0	3	0	0	0	0	7
04:45 PM	0	2	0	2	1	0	1	2	0	1	0	1	0	0	0	0	5
Total	0	12	0	12	2	0	2	4	0	15	1	16	0	0	0	0	32
05:00 PM	1	2	0	3	1	0	2	3	0	3	0	3	0	0	0	0	9
05:15 PM	0	2	0	2	0	0	1	1	0	7	1	8	0	0	0	0	11
05:30 PM	0	2	0	2	0	0	1	1	0	3	0	3	0	0	0	0	6
05:45 PM	0	1	0	1	0	0	1	1	0	1	0	1	0	0	0	0	3
Total	1	7	0	8	1	0	5	6	0	14	1	15	0	0	0	0	29
Grand Total	1	19	0	20	3	0	7	10	0	29	2	31	0	0	0	0	61
Apprch %	5	95	0		30	0	70		0	93.5	6.5		0	0	0		
Total %	1.6	31.1	0	32.8	4.9	0	11.5	16.4	0	47.5	3.3	50.8	0	0	0	0	

Start Time	Sycamore Canyon Blvd Southbound				Box Springs Blvd Westbound				Sycamore Canyon Blvd Northbound				Box Springs Blvd Eastbound				Int. Total
	Left	Thru	Right	App. Total	Left	Thru	Right	App. Total	Left	Thru	Right	App. Total	Left	Thru	Right	App. Total	
04:30 PM	0	3	0	3	1	0	0	1	0	3	0	3	0	0	0	0	7
04:45 PM	0	2	0	2	1	0	1	2	0	1	0	1	0	0	0	0	5
05:00 PM	1	2	0	3	1	0	2	3	0	3	0	3	0	0	0	0	9
05:15 PM	0	2	0	2	0	0	1	1	0	7	1	8	0	0	0	0	11
Total	1	9	0	10	3	0	4	7	0	14	1	15	0	0	0	0	32
% App. Total	10	90	0		42.9	0	57.1		0	93.3	6.7		0	0	0		
PHF	.250	.750	.000	.833	.750	.000	.500	.583	.000	.500	.250	.469	.000	.000	.000	.000	.727

Peak Hour Analysis From 04:30 PM to 05:15 PM - Peak 1 of 1

Peak Hour for Entire Intersection Begins at 04:30 PM

City of Riverside
 N/S: Sycamore Canyon Blvd
 E/W: Box Springs Blvd
 Weather: Clear

File Name : RIVSCBBPM
 Site Code : 06715392
 Start Date : 7/7/2015
 Page No : 2

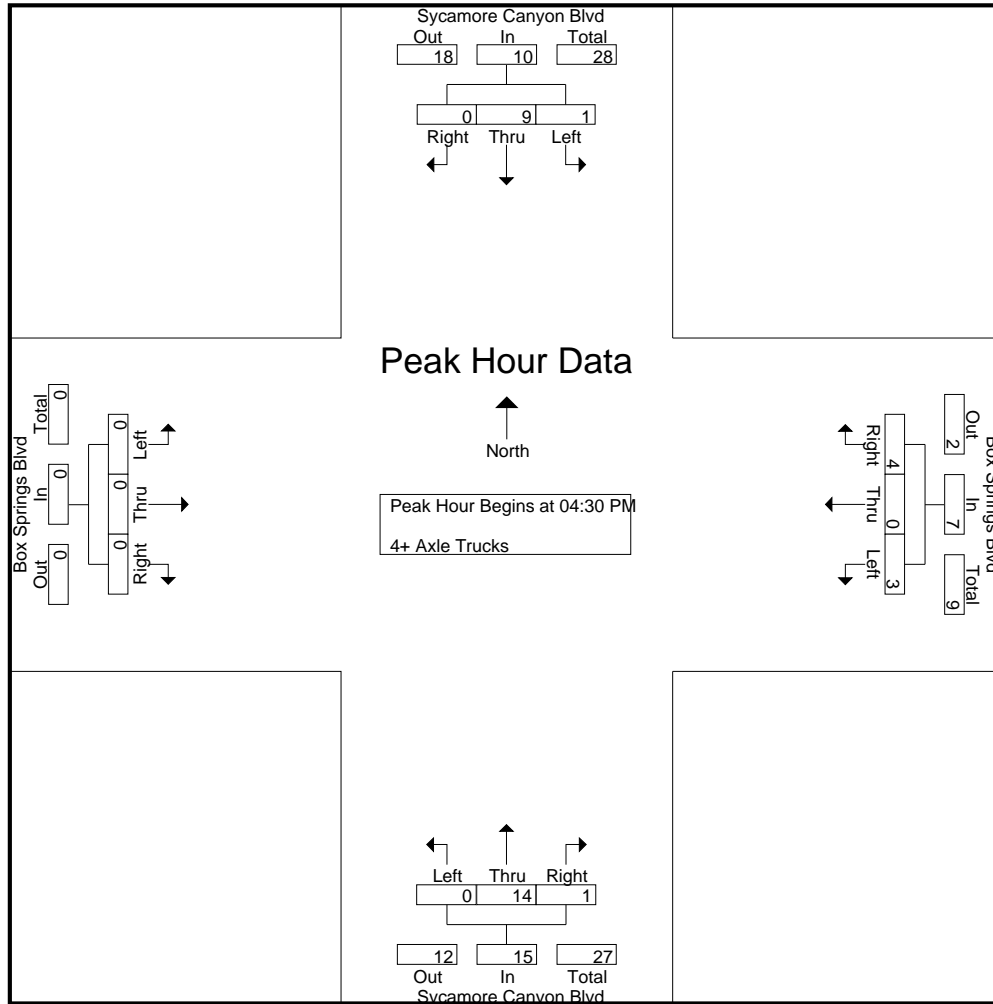

Peak Hour Analysis From 04:30 PM to 05:15 PM - Peak 1 of 1
 Peak Hour for Each Approach Begins at:

	04:30 PM				04:30 PM				04:30 PM				04:30 PM			
+0 mins.	0	3	0	3	1	0	0	1	0	3	0	3	0	0	0	0
+15 mins.	0	2	0	2	1	0	1	2	0	1	0	1	0	0	0	0
+30 mins.	1	2	0	3	1	0	2	3	0	3	0	3	0	0	0	0
+45 mins.	0	2	0	2	0	0	1	1	0	7	1	8	0	0	0	0
Total Volume	1	9	0	10	3	0	4	7	0	14	1	15	0	0	0	0
% App. Total	10	90	0		42.9	0	57.1		0	93.3	6.7		0	0	0	
PHF	.250	.750	.000	.833	.750	.000	.500	.583	.000	.500	.250	.469	.000	.000	.000	.000

Counts Unlimited Inc
 PO Box 1178
 Corona, CA 92878
 (951) 268-6268

City of Riverside
 N/S: Sycamore Canyon Blvd
 E/W: Sierra Ridge Drive
 Weather: Clear

File Name : RIVSCSRAM
 Site Code : 06715392
 Start Date : 7/7/2015
 Page No : 1

Groups Printed- Passenger Vehicles - Large 2 Axle Vehicles - 3 Axle Vehicles - 4+ Axle Trucks

Start Time	Sycamore Canyon Blvd Southbound			Sycamore Canyon Blvd Northbound			Sierra Ridge Drive Eastbound			Int. Total
	Thru	Right	App. Total	Left	Thru	App. Total	Left	Right	App. Total	
07:00 AM	54	8	62	11	272	283	3	1	4	349
07:15 AM	62	9	71	26	274	300	1	4	5	376
07:30 AM	68	9	77	36	337	373	8	5	13	463
07:45 AM	89	16	105	57	270	327	2	8	10	442
Total	273	42	315	130	1153	1283	14	18	32	1630
08:00 AM	40	10	50	27	226	253	8	12	20	323
08:15 AM	32	12	44	42	227	269	4	10	14	327
08:30 AM	41	11	52	25	209	234	13	12	25	311
08:45 AM	41	15	56	30	121	151	6	17	23	230
Total	154	48	202	124	783	907	31	51	82	1191
Grand Total	427	90	517	254	1936	2190	45	69	114	2821
Apprch %	82.6	17.4		11.6	88.4		39.5	60.5		
Total %	15.1	3.2	18.3	9	68.6	77.6	1.6	2.4	4	
Passenger Vehicles	388	73	461	240	1774	2014	30	63	93	2568
% Passenger Vehicles	90.9	81.1	89.2	94.5	91.6	92	66.7	91.3	81.6	91
Large 2 Axle Vehicles	13	5	18	11	52	63	4	3	7	88
% Large 2 Axle Vehicles	3	5.6	3.5	4.3	2.7	2.9	8.9	4.3	6.1	3.1
3 Axle Vehicles	4	0	4	0	15	15	0	0	0	19
% 3 Axle Vehicles	0.9	0	0.8	0	0.8	0.7	0	0	0	0.7
4+ Axle Trucks	22	12	34	3	95	98	11	3	14	146
% 4+ Axle Trucks	5.2	13.3	6.6	1.2	4.9	4.5	24.4	4.3	12.3	5.2

Start Time	Sycamore Canyon Blvd Southbound			Sycamore Canyon Blvd Northbound			Sierra Ridge Drive Eastbound			Int. Total
	Thru	Right	App. Total	Left	Thru	App. Total	Left	Right	App. Total	
Peak Hour Analysis From 07:00 AM to 08:45 AM - Peak 1 of 1										
Peak Hour for Entire Intersection Begins at 07:00 AM										
07:00 AM	54	8	62	11	272	283	3	1	4	349
07:15 AM	62	9	71	26	274	300	1	4	5	376
07:30 AM	68	9	77	36	337	373	8	5	13	463
07:45 AM	89	16	105	57	270	327	2	8	10	442
Total Volume	273	42	315	130	1153	1283	14	18	32	1630
% App. Total	86.7	13.3		10.1	89.9		43.8	56.2		
PHF	.767	.656	.750	.570	.855	.860	.438	.563	.615	.880

City of Riverside
 N/S: Sycamore Canyon Blvd
 E/W: Sierra Ridge Drive
 Weather: Clear

File Name : RIVSCSRAM
 Site Code : 06715392
 Start Date : 7/7/2015
 Page No : 2

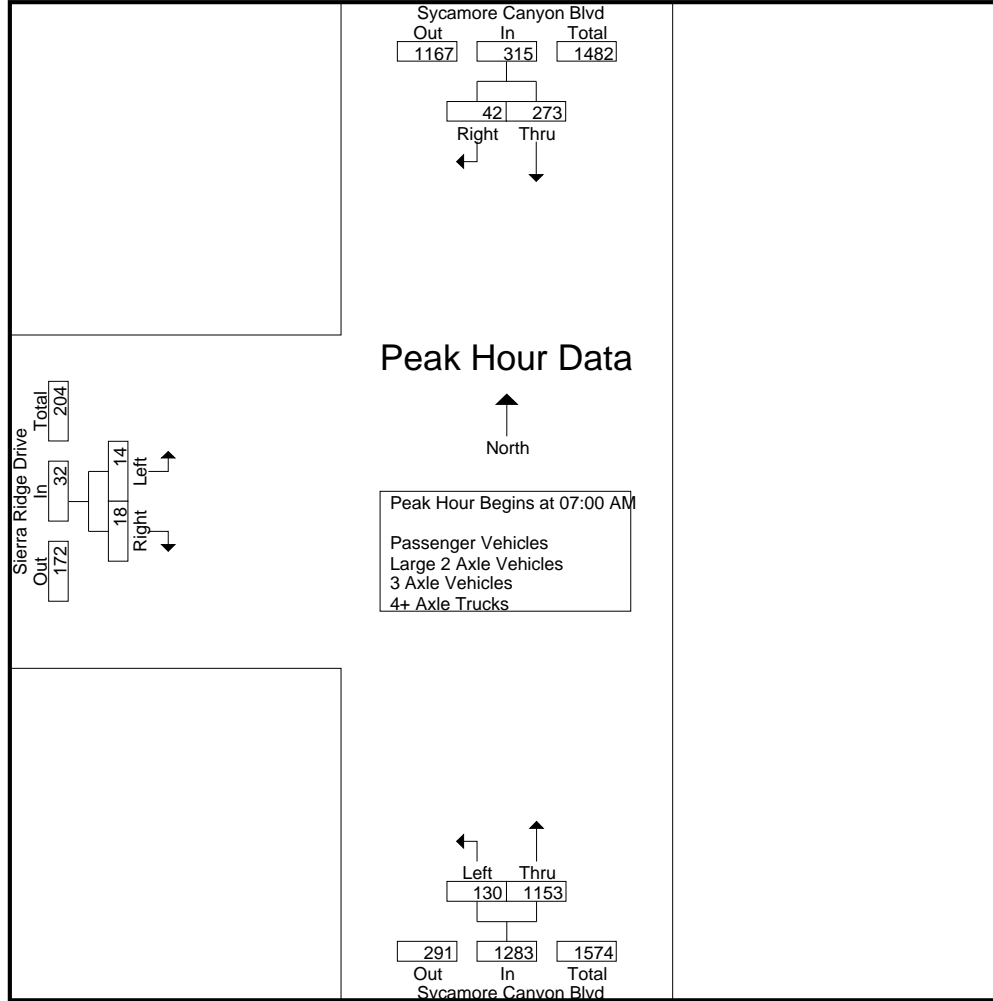

Peak Hour Analysis From 07:00 AM to 08:45 AM - Peak 1 of 1
 Peak Hour for Each Approach Begins at:

	07:00 AM			07:00 AM			08:00 AM		
+0 mins.	54	8	62	11	272	283	8	12	20
+15 mins.	62	9	71	26	274	300	4	10	14
+30 mins.	68	9	77	36	337	373	13	12	25
+45 mins.	89	16	105	57	270	327	6	17	23
Total Volume	273	42	315	130	1153	1283	31	51	82
% App. Total	86.7	13.3		10.1	89.9		37.8	62.2	
PHF	.767	.656	.750	.570	.855	.860	.596	.750	.820

Counts Unlimited Inc
 PO Box 1178
 Corona, CA 92878
 (951) 268-6268

City of Riverside
 N/S: Sycamore Canyon Blvd
 E/W: Sierra Ridge Drive
 Weather: Clear

File Name : RIVSCSRAM
 Site Code : 06715392
 Start Date : 7/7/2015
 Page No : 1

Groups Printed- Passenger Vehicles

Start Time	Sycamore Canyon Blvd Southbound			Sycamore Canyon Blvd Northbound			Sierra Ridge Drive Eastbound			Int. Total
	Thru	Right	App. Total	Left	Thru	App. Total	Left	Right	App. Total	
07:00 AM	48	5	53	10	243	253	3	0	3	309
07:15 AM	56	6	62	25	254	279	0	2	2	343
07:30 AM	66	5	71	32	314	346	4	5	9	426
07:45 AM	82	13	95	54	251	305	1	7	8	408
Total	252	29	281	121	1062	1183	8	14	22	1486
08:00 AM	38	8	46	27	200	227	6	11	17	290
08:15 AM	28	10	38	40	205	245	2	9	11	294
08:30 AM	36	11	47	23	198	221	10	12	22	290
08:45 AM	34	15	49	29	109	138	4	17	21	208
Total	136	44	180	119	712	831	22	49	71	1082
Grand Total	388	73	461	240	1774	2014	30	63	93	2568
Apprch %	84.2	15.8		11.9	88.1		32.3	67.7		
Total %	15.1	2.8	18	9.3	69.1	78.4	1.2	2.5	3.6	

Start Time	Sycamore Canyon Blvd Southbound			Sycamore Canyon Blvd Northbound			Sierra Ridge Drive Eastbound			Int. Total
	Thru	Right	App. Total	Left	Thru	App. Total	Left	Right	App. Total	
07:00 AM	48	5	53	10	243	253	3	0	3	309
07:15 AM	56	6	62	25	254	279	0	2	2	343
07:30 AM	66	5	71	32	314	346	4	5	9	426
07:45 AM	82	13	95	54	251	305	1	7	8	408
Total Volume	252	29	281	121	1062	1183	8	14	22	1486
% App. Total	89.7	10.3		10.2	89.8		36.4	63.6		
PHF	.768	.558	.739	.560	.846	.855	.500	.500	.611	.872

Peak Hour Analysis From 07:00 AM to 07:45 AM - Peak 1 of 1
 Peak Hour for Entire Intersection Begins at 07:00 AM

City of Riverside
 N/S: Sycamore Canyon Blvd
 E/W: Sierra Ridge Drive
 Weather: Clear

File Name : RIVSCSRAM
 Site Code : 06715392
 Start Date : 7/7/2015
 Page No : 2

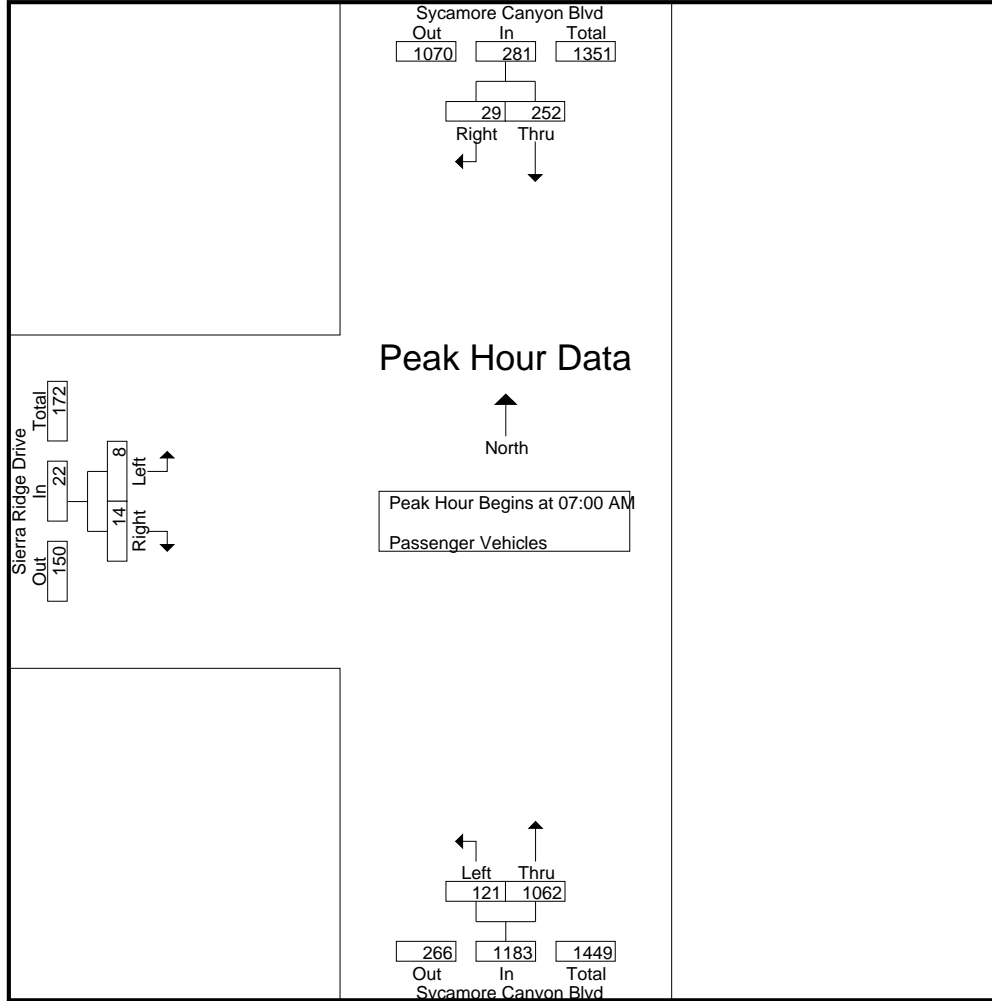

Peak Hour Analysis From 07:00 AM to 07:45 AM - Peak 1 of 1
 Peak Hour for Each Approach Begins at:

	07:00 AM			07:00 AM			07:00 AM		
+0 mins.	48	5	53	10	243	253	3	0	3
+15 mins.	56	6	62	25	254	279	0	2	2
+30 mins.	66	5	71	32	314	346	4	5	9
+45 mins.	82	13	95	54	251	305	1	7	8
Total Volume	252	29	281	121	1062	1183	8	14	22
% App. Total	89.7	10.3		10.2	89.8		36.4	63.6	
PHF	.768	.558	.739	.560	.846	.855	.500	.500	.611

Counts Unlimited Inc
 PO Box 1178
 Corona, CA 92878
 (951) 268-6268

City of Riverside
 N/S: Sycamore Canyon Blvd
 E/W: Sierra Ridge Drive
 Weather: Clear

File Name : RIVSCSRAM
 Site Code : 06715392
 Start Date : 7/7/2015
 Page No : 1

Groups Printed- Large 2 Axle Vehicles

Start Time	Sycamore Canyon Blvd Southbound			Sycamore Canyon Blvd Northbound			Sierra Ridge Drive Eastbound			Int. Total
	Thru	Right	App. Total	Left	Thru	App. Total	Left	Right	App. Total	
07:00 AM	2	1	3	1	12	13	0	0	0	16
07:15 AM	2	0	2	1	8	9	0	1	1	12
07:30 AM	0	1	1	3	6	9	0	0	0	10
07:45 AM	2	1	3	2	8	10	0	1	1	14
Total	6	3	9	7	34	41	0	2	2	52
08:00 AM	2	1	3	0	5	5	1	0	1	9
08:15 AM	2	1	3	1	6	7	0	1	1	11
08:30 AM	1	0	1	2	1	3	1	0	1	5
08:45 AM	2	0	2	1	6	7	2	0	2	11
Total	7	2	9	4	18	22	4	1	5	36
Grand Total	13	5	18	11	52	63	4	3	7	88
Apprch %	72.2	27.8		17.5	82.5		57.1	42.9		
Total %	14.8	5.7	20.5	12.5	59.1	71.6	4.5	3.4	8	

Start Time	Sycamore Canyon Blvd Southbound			Sycamore Canyon Blvd Northbound			Sierra Ridge Drive Eastbound			Int. Total
	Thru	Right	App. Total	Left	Thru	App. Total	Left	Right	App. Total	
07:00 AM	2	1	3	1	12	13	0	0	0	16
07:15 AM	2	0	2	1	8	9	0	1	1	12
07:30 AM	0	1	1	3	6	9	0	0	0	10
07:45 AM	2	1	3	2	8	10	0	1	1	14
Total Volume	6	3	9	7	34	41	0	2	2	52
% App. Total	66.7	33.3		17.1	82.9		0	100		
PHF	.750	.750	.750	.583	.708	.788	.000	.500	.500	.813

Peak Hour Analysis From 07:00 AM to 07:45 AM - Peak 1 of 1
 Peak Hour for Entire Intersection Begins at 07:00 AM

City of Riverside
 N/S: Sycamore Canyon Blvd
 E/W: Sierra Ridge Drive
 Weather: Clear

File Name : RIVSCSRAM
 Site Code : 06715392
 Start Date : 7/7/2015
 Page No : 2

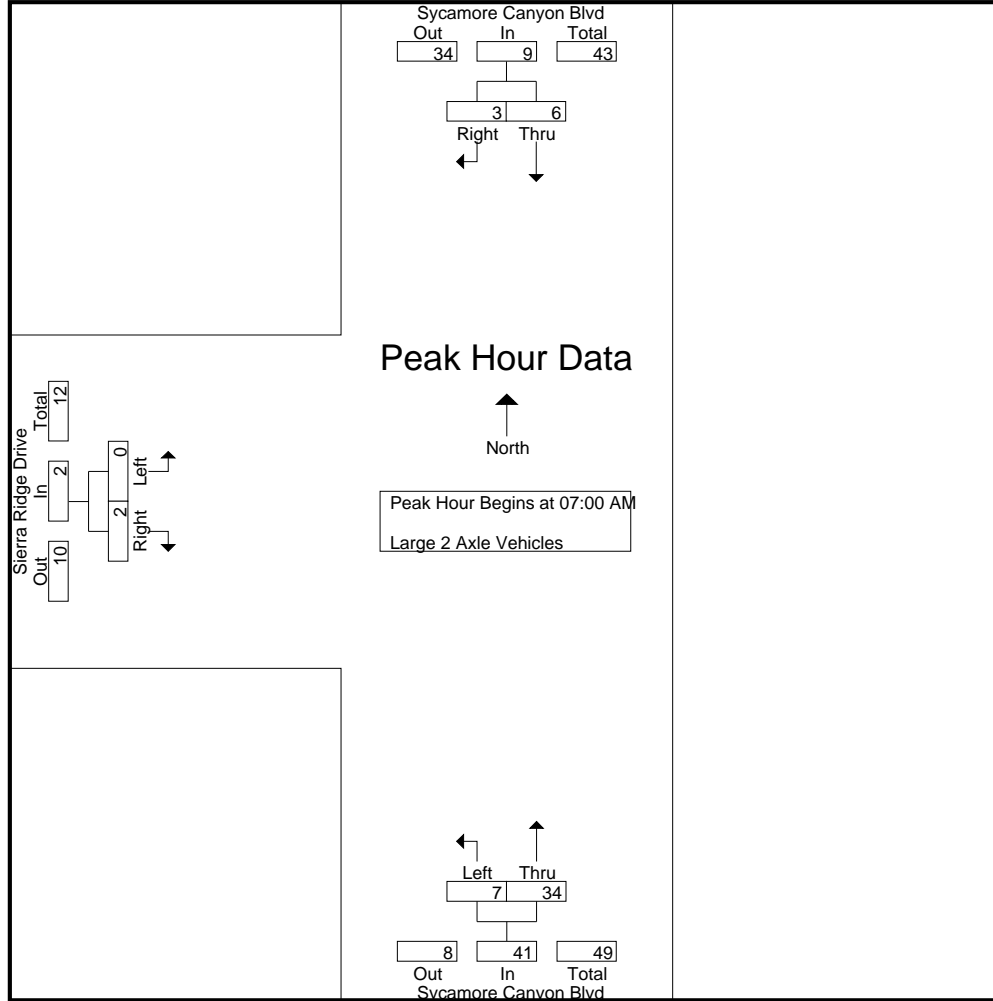

Peak Hour Analysis From 07:00 AM to 07:45 AM - Peak 1 of 1
 Peak Hour for Each Approach Begins at:

	07:00 AM			07:00 AM			07:00 AM		
+0 mins.	2	1	3	1	12	13	0	0	0
+15 mins.	2	0	2	1	8	9	0	1	1
+30 mins.	0	1	1	3	6	9	0	0	0
+45 mins.	2	1	3	2	8	10	0	1	1
Total Volume	6	3	9	7	34	41	0	2	2
% App. Total	66.7	33.3		17.1	82.9		0	100	
PHF	.750	.750	.750	.583	.708	.788	.000	.500	.500

Counts Unlimited Inc
 PO Box 1178
 Corona, CA 92878
 (951) 268-6268

City of Riverside
 N/S: Sycamore Canyon Blvd
 E/W: Sierra Ridge Drive
 Weather: Clear

File Name : RIVSCSRAM
 Site Code : 06715392
 Start Date : 7/7/2015
 Page No : 1

Groups Printed- 3 Axle Vehicles

Start Time	Sycamore Canyon Blvd Southbound			Sycamore Canyon Blvd Northbound			Sierra Ridge Drive Eastbound			Int. Total
	Thru	Right	App. Total	Left	Thru	App. Total	Left	Right	App. Total	
07:00 AM	0	0	0	0	0	0	0	0	0	0
07:15 AM	1	0	1	0	2	2	0	0	0	3
07:30 AM	0	0	0	0	4	4	0	0	0	4
07:45 AM	3	0	3	0	2	2	0	0	0	5
Total	4	0	4	0	8	8	0	0	0	12
08:00 AM	0	0	0	0	4	4	0	0	0	4
08:15 AM	0	0	0	0	0	0	0	0	0	0
08:30 AM	0	0	0	0	3	3	0	0	0	3
08:45 AM	0	0	0	0	0	0	0	0	0	0
Total	0	0	0	0	7	7	0	0	0	7
Grand Total	4	0	4	0	15	15	0	0	0	19
Apprch %	100	0		0	100		0	0		
Total %	21.1	0	21.1	0	78.9	78.9	0	0	0	

Start Time	Sycamore Canyon Blvd Southbound			Sycamore Canyon Blvd Northbound			Sierra Ridge Drive Eastbound			Int. Total
	Thru	Right	App. Total	Left	Thru	App. Total	Left	Right	App. Total	
Peak Hour Analysis From 07:00 AM to 07:45 AM - Peak 1 of 1										
Peak Hour for Entire Intersection Begins at 07:00 AM										
07:00 AM	0	0	0	0	0	0	0	0	0	0
07:15 AM	1	0	1	0	2	2	0	0	0	3
07:30 AM	0	0	0	0	4	4	0	0	0	4
07:45 AM	3	0	3	0	2	2	0	0	0	5
Total Volume	4	0	4	0	8	8	0	0	0	12
% App. Total	100	0		0	100		0	0		
PHF	.333	.000	.333	.000	.500	.500	.000	.000	.000	.600

City of Riverside
 N/S: Sycamore Canyon Blvd
 E/W: Sierra Ridge Drive
 Weather: Clear

File Name : RIVSCSRAM
 Site Code : 06715392
 Start Date : 7/7/2015
 Page No : 2

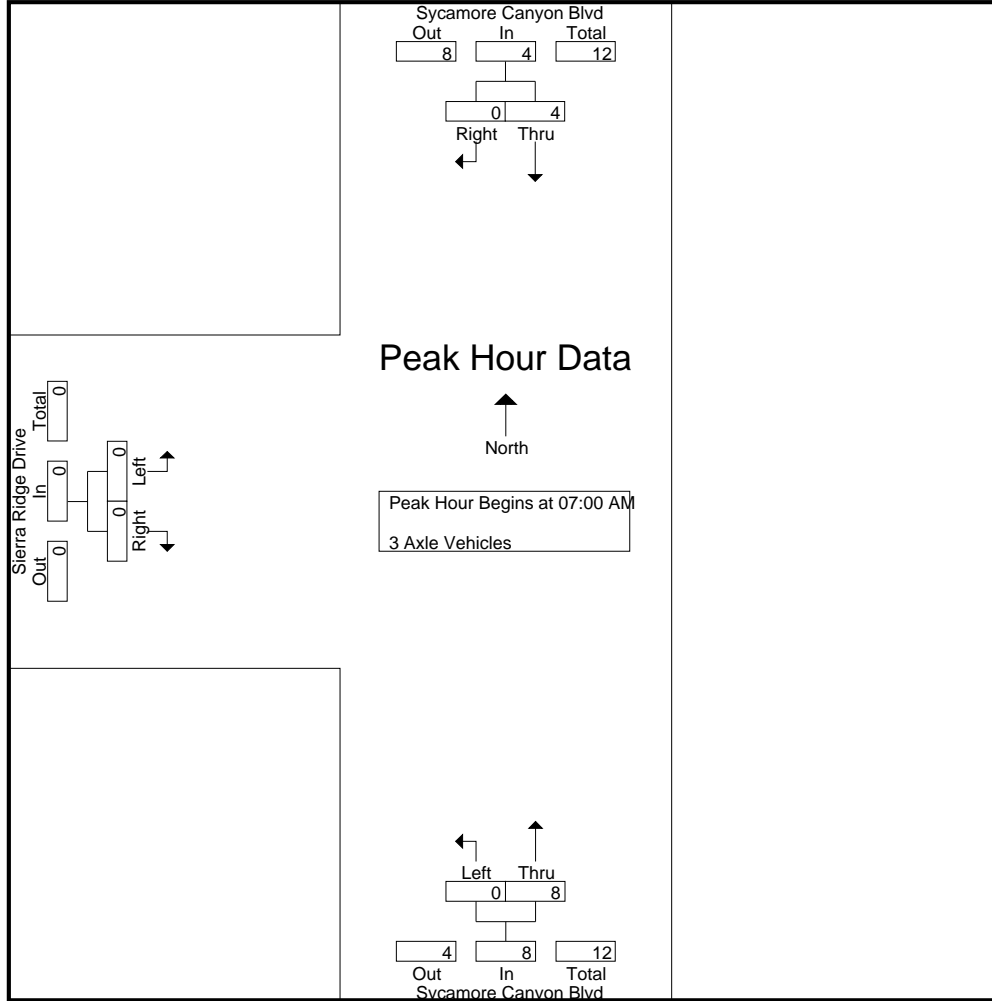

Peak Hour Analysis From 07:00 AM to 07:45 AM - Peak 1 of 1
 Peak Hour for Each Approach Begins at:

	07:00 AM			07:00 AM			07:00 AM		
+0 mins.	0	0	0	0	0	0	0	0	0
+15 mins.	1	0	1	0	2	2	0	0	0
+30 mins.	0	0	0	0	4	4	0	0	0
+45 mins.	3	0	3	0	2	2	0	0	0
Total Volume	4	0	4	0	8	8	0	0	0
% App. Total	100	0		0	100		0	0	
PHF	.333	.000	.333	.000	.500	.500	.000	.000	.000

Counts Unlimited Inc
 PO Box 1178
 Corona, CA 92878
 (951) 268-6268

City of Riverside
 N/S: Sycamore Canyon Blvd
 E/W: Sierra Ridge Drive
 Weather: Clear

File Name : RIVSCSRAM
 Site Code : 06715392
 Start Date : 7/7/2015
 Page No : 1

Groups Printed- 4+ Axle Trucks

Start Time	Sycamore Canyon Blvd Southbound			Sycamore Canyon Blvd Northbound			Sierra Ridge Drive Eastbound			Int. Total
	Thru	Right	App. Total	Left	Thru	App. Total	Left	Right	App. Total	
07:00 AM	4	2	6	0	17	17	0	1	1	24
07:15 AM	3	3	6	0	10	10	1	1	2	18
07:30 AM	2	3	5	1	13	14	4	0	4	23
07:45 AM	2	2	4	1	9	10	1	0	1	15
Total	11	10	21	2	49	51	6	2	8	80
08:00 AM	0	1	1	0	17	17	1	1	2	20
08:15 AM	2	1	3	1	16	17	2	0	2	22
08:30 AM	4	0	4	0	7	7	2	0	2	13
08:45 AM	5	0	5	0	6	6	0	0	0	11
Total	11	2	13	1	46	47	5	1	6	66
Grand Total	22	12	34	3	95	98	11	3	14	146
Apprch %	64.7	35.3		3.1	96.9		78.6	21.4		
Total %	15.1	8.2	23.3	2.1	65.1	67.1	7.5	2.1	9.6	

Start Time	Sycamore Canyon Blvd Southbound			Sycamore Canyon Blvd Northbound			Sierra Ridge Drive Eastbound			Int. Total
	Thru	Right	App. Total	Left	Thru	App. Total	Left	Right	App. Total	
07:00 AM	4	2	6	0	17	17	0	1	1	24
07:15 AM	3	3	6	0	10	10	1	1	2	18
07:30 AM	2	3	5	1	13	14	4	0	4	23
07:45 AM	2	2	4	1	9	10	1	0	1	15
Total Volume	11	10	21	2	49	51	6	2	8	80
% App. Total	52.4	47.6		3.9	96.1		75	25		
PHF	.688	.833	.875	.500	.721	.750	.375	.500	.500	.833

Peak Hour Analysis From 07:00 AM to 07:45 AM - Peak 1 of 1
 Peak Hour for Entire Intersection Begins at 07:00 AM

City of Riverside
 N/S: Sycamore Canyon Blvd
 E/W: Sierra Ridge Drive
 Weather: Clear

File Name : RIVSCSRAM
 Site Code : 06715392
 Start Date : 7/7/2015
 Page No : 2

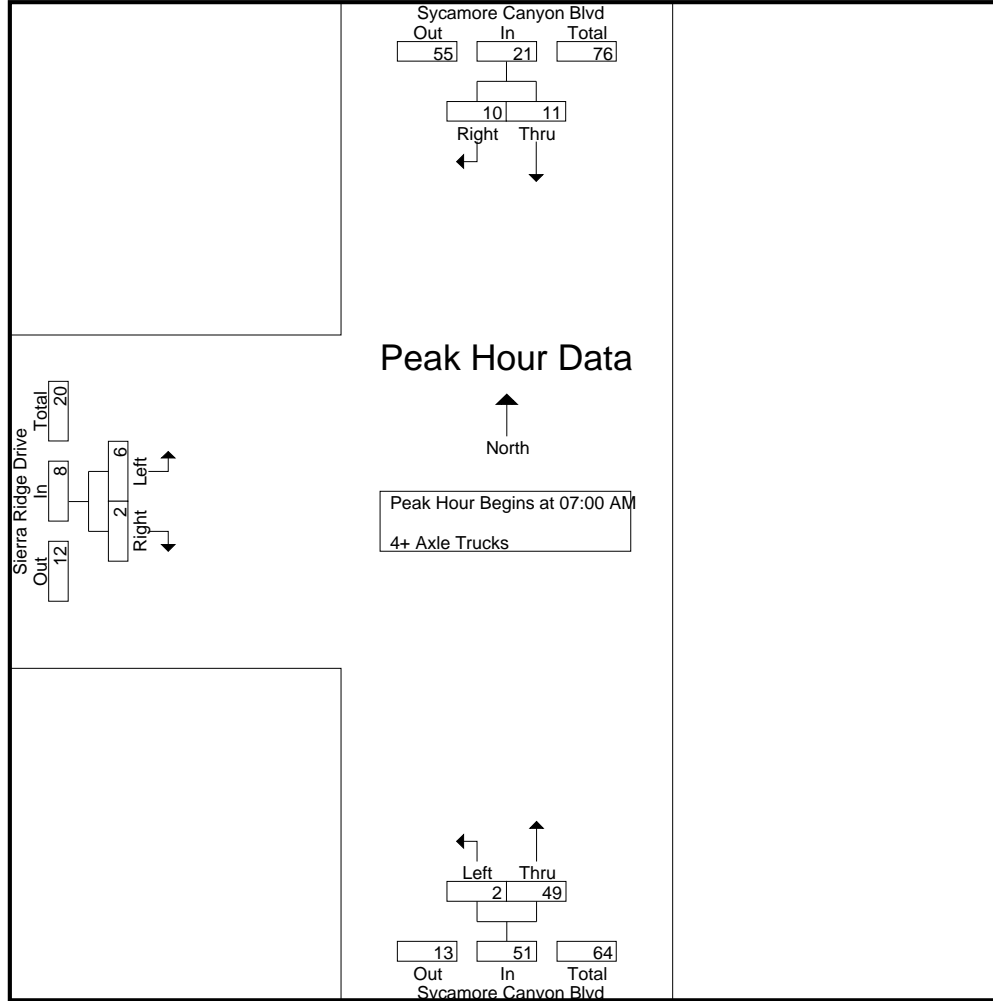

Peak Hour Analysis From 07:00 AM to 07:45 AM - Peak 1 of 1
 Peak Hour for Each Approach Begins at:

	07:00 AM			07:00 AM			07:00 AM		
+0 mins.	4	2	6	0	17	17	0	1	1
+15 mins.	3	3	6	0	10	10	1	1	2
+30 mins.	2	3	5	1	13	14	4	0	4
+45 mins.	2	2	4	1	9	10	1	0	1
Total Volume	11	10	21	2	49	51	6	2	8
% App. Total	52.4	47.6		3.9	96.1		75	25	
PHF	.688	.833	.875	.500	.721	.750	.375	.500	.500

City of Riverside
 N/S: Sycamore Canyon Blvd
 E/W: Sierra Ridge Drive
 Weather: Clear

File Name : RIVSCSRPM
 Site Code : 06715392
 Start Date : 7/7/2015
 Page No : 1

Groups Printed- Passenger Vehicles - Large 2 Axle Vehicles - 3 Axle Vehicles - 4+ Axle Trucks

Start Time	Sycamore Canyon Blvd Southbound			Sycamore Canyon Blvd Northbound			Sierra Ridge Drive Eastbound			Int. Total
	Thru	Right	App. Total	Left	Thru	App. Total	Left	Right	App. Total	
04:00 PM	100	16	116	30	107	137	21	29	50	303
04:15 PM	55	14	69	22	99	121	18	16	34	224
04:30 PM	86	11	97	30	99	129	17	25	42	268
04:45 PM	91	6	97	29	92	121	9	14	23	241
Total	332	47	379	111	397	508	65	84	149	1036
05:00 PM	113	3	116	2	140	142	15	22	37	295
05:15 PM	107	3	110	6	108	114	17	22	39	263
05:30 PM	96	3	99	9	74	83	9	6	15	197
05:45 PM	84	2	86	7	80	87	7	2	9	182
Total	400	11	411	24	402	426	48	52	100	937
Grand Total	732	58	790	135	799	934	113	136	249	1973
Apprch %	92.7	7.3		14.5	85.5		45.4	54.6		
Total %	37.1	2.9	40	6.8	40.5	47.3	5.7	6.9	12.6	
Passenger Vehicles	703	54	757	130	747	877	103	130	233	1867
% Passenger Vehicles	96	93.1	95.8	96.3	93.5	93.9	91.2	95.6	93.6	94.6
Large 2 Axle Vehicles	10	0	10	1	18	19	0	3	3	32
% Large 2 Axle Vehicles	1.4	0	1.3	0.7	2.3	2	0	2.2	1.2	1.6
3 Axle Vehicles	1	0	1	0	3	3	1	0	1	5
% 3 Axle Vehicles	0.1	0	0.1	0	0.4	0.3	0.9	0	0.4	0.3
4+ Axle Trucks	18	4	22	4	31	35	9	3	12	69
% 4+ Axle Trucks	2.5	6.9	2.8	3	3.9	3.7	8	2.2	4.8	3.5

Start Time	Sycamore Canyon Blvd Southbound			Sycamore Canyon Blvd Northbound			Sierra Ridge Drive Eastbound			Int. Total
	Thru	Right	App. Total	Left	Thru	App. Total	Left	Right	App. Total	
Peak Hour Analysis From 04:00 PM to 05:45 PM - Peak 1 of 1										
Peak Hour for Entire Intersection Begins at 04:30 PM										
04:30 PM	86	11	97	30	99	129	17	25	42	268
04:45 PM	91	6	97	29	92	121	9	14	23	241
05:00 PM	113	3	116	2	140	142	15	22	37	295
05:15 PM	107	3	110	6	108	114	17	22	39	263
Total Volume	397	23	420	67	439	506	58	83	141	1067
% App. Total	94.5	5.5		13.2	86.8		41.1	58.9		
PHF	.878	.523	.905	.558	.784	.891	.853	.830	.839	.904

City of Riverside
 N/S: Sycamore Canyon Blvd
 E/W: Sierra Ridge Drive
 Weather: Clear

File Name : RIVSCSRPM
 Site Code : 06715392
 Start Date : 7/7/2015
 Page No : 2

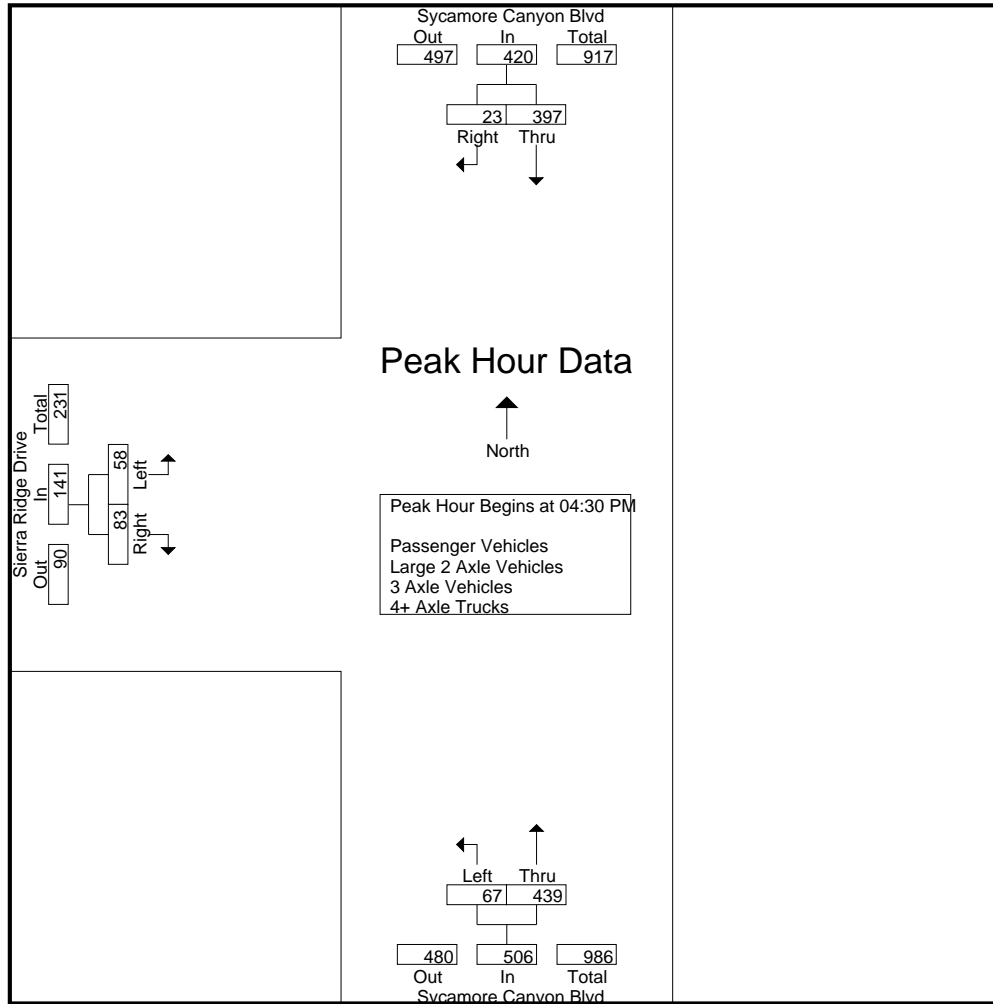

Peak Hour Analysis From 04:00 PM to 05:45 PM - Peak 1 of 1
 Peak Hour for Each Approach Begins at:

	04:45 PM			04:15 PM			04:00 PM		
+0 mins.	91	6	97	22	99	121	21	29	50
+15 mins.	113	3	116	30	99	129	18	16	34
+30 mins.	107	3	110	29	92	121	17	25	42
+45 mins.	96	3	99	2	140	142	9	14	23
Total Volume	407	15	422	83	430	513	65	84	149
% App. Total	96.4	3.6		16.2	83.8		43.6	56.4	
PHF	.900	.625	.909	.692	.768	.903	.774	.724	.745

City of Riverside
 N/S: Sycamore Canyon Blvd
 E/W: Sierra Ridge Drive
 Weather: Clear

File Name : RIVSCSRPM
 Site Code : 06715392
 Start Date : 7/7/2015
 Page No : 1

Groups Printed- Passenger Vehicles

Start Time	Sycamore Canyon Blvd Southbound			Sycamore Canyon Blvd Northbound			Sierra Ridge Drive Eastbound			Int. Total
	Thru	Right	App. Total	Left	Thru	App. Total	Left	Right	App. Total	
04:00 PM	96	15	111	28	96	124	19	27	46	281
04:15 PM	51	14	65	22	96	118	18	16	34	217
04:30 PM	83	11	94	28	92	120	15	25	40	254
04:45 PM	88	6	94	29	85	114	9	12	21	229
Total	318	46	364	107	369	476	61	80	141	981
05:00 PM	107	2	109	2	135	137	15	21	36	282
05:15 PM	104	2	106	5	99	104	16	21	37	247
05:30 PM	92	3	95	9	67	76	8	6	14	185
05:45 PM	82	1	83	7	77	84	3	2	5	172
Total	385	8	393	23	378	401	42	50	92	886
Grand Total	703	54	757	130	747	877	103	130	233	1867
Apprch %	92.9	7.1		14.8	85.2		44.2	55.8		
Total %	37.7	2.9	40.5	7	40	47	5.5	7	12.5	

Start Time	Sycamore Canyon Blvd Southbound			Sycamore Canyon Blvd Northbound			Sierra Ridge Drive Eastbound			Int. Total
	Thru	Right	App. Total	Left	Thru	App. Total	Left	Right	App. Total	
04:30 PM	83	11	94	28	92	120	15	25	40	254
04:45 PM	88	6	94	29	85	114	9	12	21	229
05:00 PM	107	2	109	2	135	137	15	21	36	282
05:15 PM	104	2	106	5	99	104	16	21	37	247
Total Volume	382	21	403	64	411	475	55	79	134	1012
% App. Total	94.8	5.2		13.5	86.5		41	59		
PHF	.893	.477	.924	.552	.761	.867	.859	.790	.838	.897

Peak Hour Analysis From 04:30 PM to 05:15 PM - Peak 1 of 1
 Peak Hour for Entire Intersection Begins at 04:30 PM

City of Riverside
 N/S: Sycamore Canyon Blvd
 E/W: Sierra Ridge Drive
 Weather: Clear

File Name : RIVSCSRPM
 Site Code : 06715392
 Start Date : 7/7/2015
 Page No : 2

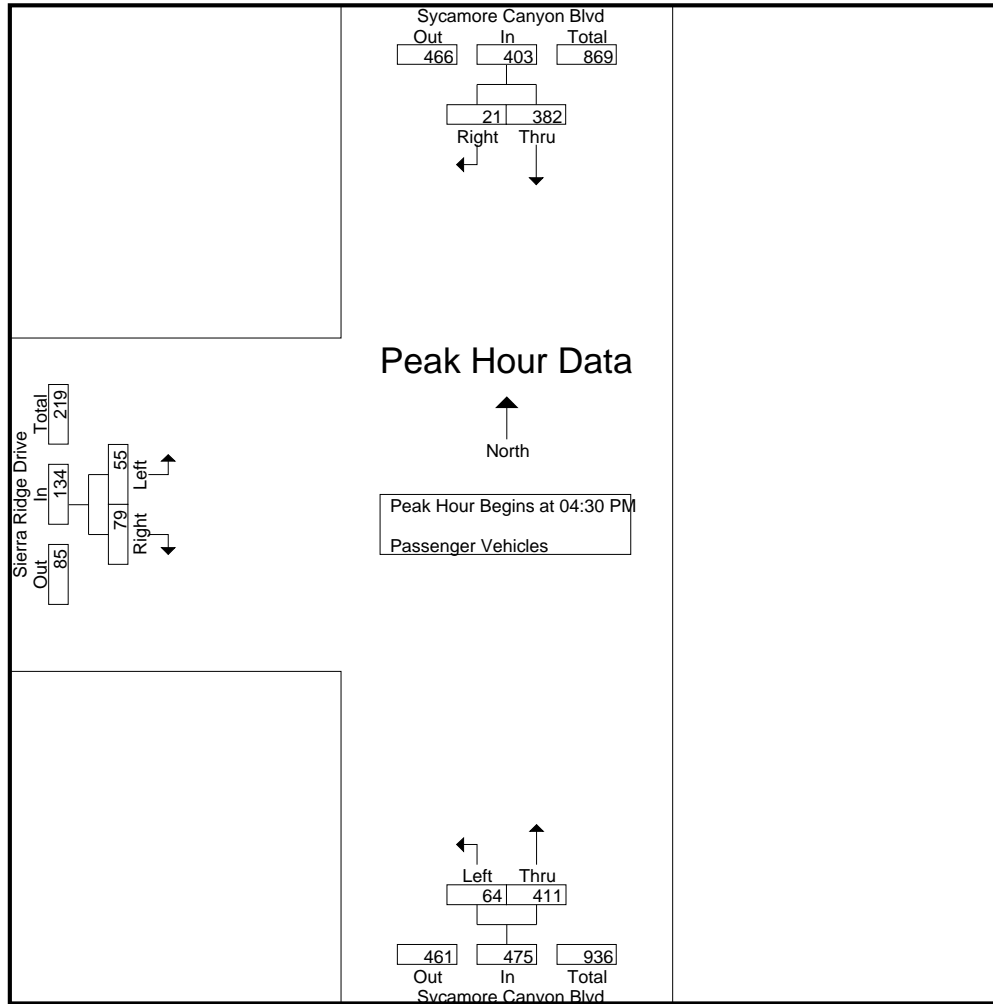

Peak Hour Analysis From 04:30 PM to 05:15 PM - Peak 1 of 1
 Peak Hour for Each Approach Begins at:

	04:30 PM			04:30 PM			04:30 PM		
+0 mins.	83	11	94	28	92	120	15	25	40
+15 mins.	88	6	94	29	85	114	9	12	21
+30 mins.	107	2	109	2	135	137	15	21	36
+45 mins.	104	2	106	5	99	104	16	21	37
Total Volume	382	21	403	64	411	475	55	79	134
% App. Total	94.8	5.2		13.5	86.5		41	59	
PHF	.893	.477	.924	.552	.761	.867	.859	.790	.838

City of Riverside
 N/S: Sycamore Canyon Blvd
 E/W: Sierra Ridge Drive
 Weather: Clear

File Name : RIVSCSRPM
 Site Code : 06715392
 Start Date : 7/7/2015
 Page No : 1

Groups Printed- Large 2 Axle Vehicles

Start Time	Sycamore Canyon Blvd Southbound			Sycamore Canyon Blvd Northbound			Sierra Ridge Drive Eastbound			Int. Total
	Thru	Right	App. Total	Left	Thru	App. Total	Left	Right	App. Total	
04:00 PM	1	0	1	0	5	5	0	1	1	7
04:15 PM	1	0	1	0	0	0	0	0	0	1
04:30 PM	1	0	1	1	3	4	0	0	0	5
04:45 PM	2	0	2	0	2	2	0	2	2	6
Total	5	0	5	1	10	11	0	3	3	19
05:00 PM	1	0	1	0	2	2	0	0	0	3
05:15 PM	1	0	1	0	1	1	0	0	0	2
05:30 PM	3	0	3	0	3	3	0	0	0	6
05:45 PM	0	0	0	0	2	2	0	0	0	2
Total	5	0	5	0	8	8	0	0	0	13
Grand Total	10	0	10	1	18	19	0	3	3	32
Apprch %	100	0		5.3	94.7		0	100		
Total %	31.2	0	31.2	3.1	56.2	59.4	0	9.4	9.4	

Start Time	Sycamore Canyon Blvd Southbound			Sycamore Canyon Blvd Northbound			Sierra Ridge Drive Eastbound			Int. Total
	Thru	Right	App. Total	Left	Thru	App. Total	Left	Right	App. Total	
04:30 PM	1	0	1	1	3	4	0	0	0	5
04:45 PM	2	0	2	0	2	2	0	2	2	6
05:00 PM	1	0	1	0	2	2	0	0	0	3
05:15 PM	1	0	1	0	1	1	0	0	0	2
Total Volume	5	0	5	1	8	9	0	2	2	16
% App. Total	100	0		11.1	88.9		0	100		
PHF	.625	.000	.625	.250	.667	.563	.000	.250	.250	.667

Peak Hour Analysis From 04:30 PM to 05:15 PM - Peak 1 of 1
 Peak Hour for Entire Intersection Begins at 04:30 PM

City of Riverside
 N/S: Sycamore Canyon Blvd
 E/W: Sierra Ridge Drive
 Weather: Clear

File Name : RIVSCSRPM
 Site Code : 06715392
 Start Date : 7/7/2015
 Page No : 2

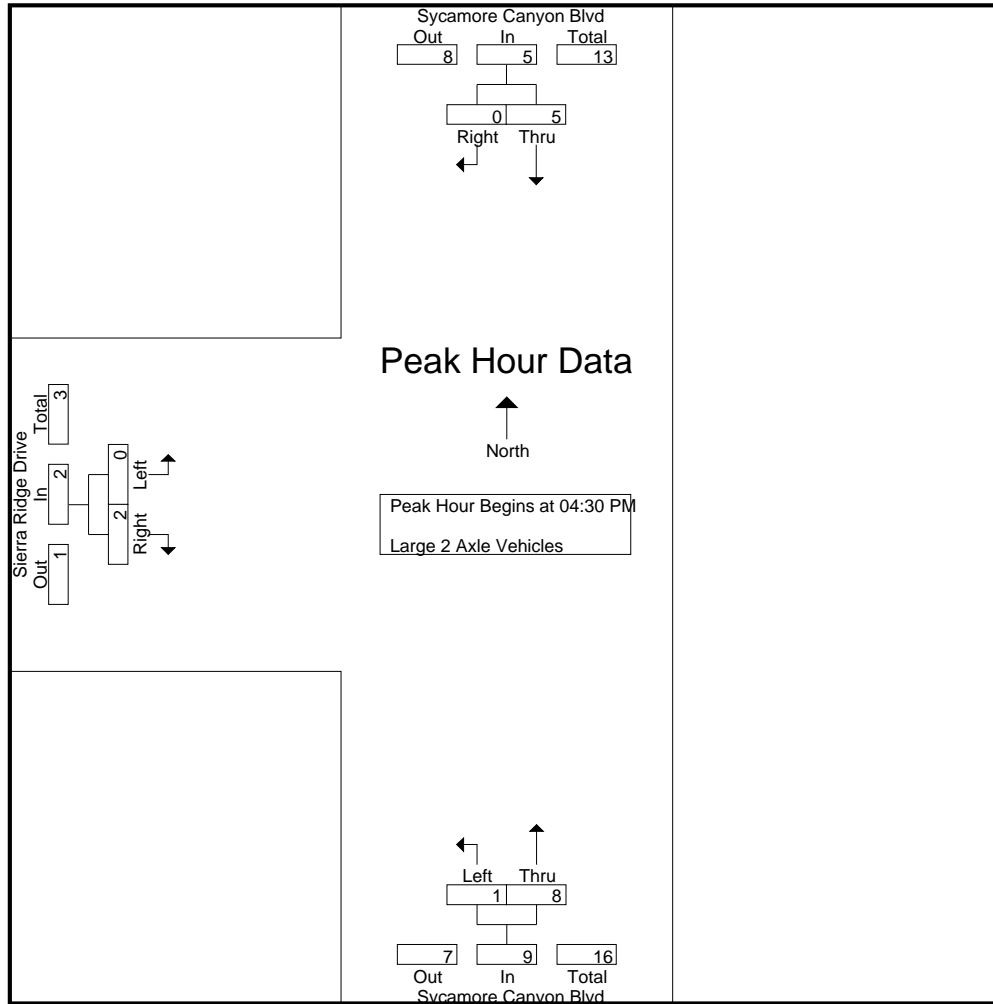

Peak Hour Analysis From 04:30 PM to 05:15 PM - Peak 1 of 1
 Peak Hour for Each Approach Begins at:

	04:30 PM			04:30 PM			04:30 PM		
+0 mins.	1	0	1	1	3	4	0	0	0
+15 mins.	2	0	2	0	2	2	0	2	2
+30 mins.	1	0	1	0	2	2	0	0	0
+45 mins.	1	0	1	0	1	1	0	0	0
Total Volume	5	0	5	1	8	9	0	2	2
% App. Total	100	0		11.1	88.9		0	100	
PHF	.625	.000	.625	.250	.667	.563	.000	.250	.250

City of Riverside
 N/S: Sycamore Canyon Blvd
 E/W: Sierra Ridge Drive
 Weather: Clear

File Name : RIVSCSRPM
 Site Code : 06715392
 Start Date : 7/7/2015
 Page No : 1

Groups Printed- 3 Axle Vehicles

Start Time	Sycamore Canyon Blvd Southbound			Sycamore Canyon Blvd Northbound			Sierra Ridge Drive Eastbound			Int. Total
	Thru	Right	App. Total	Left	Thru	App. Total	Left	Right	App. Total	
04:00 PM	0	0	0	0	1	1	0	0	0	1
04:15 PM	0	0	0	0	0	0	0	0	0	0
04:30 PM	0	0	0	0	0	0	0	0	0	0
04:45 PM	0	0	0	0	0	0	0	0	0	0
Total	0	0	0	0	1	1	0	0	0	1
05:00 PM	1	0	1	0	0	0	0	0	0	1
05:15 PM	0	0	0	0	0	0	0	0	0	0
05:30 PM	0	0	0	0	1	1	0	0	0	1
05:45 PM	0	0	0	0	1	1	1	0	1	2
Total	1	0	1	0	2	2	1	0	1	4
Grand Total	1	0	1	0	3	3	1	0	1	5
Apprch %	100	0		0	100		100	0		
Total %	20	0	20	0	60	60	20	0	20	

Start Time	Sycamore Canyon Blvd Southbound			Sycamore Canyon Blvd Northbound			Sierra Ridge Drive Eastbound			Int. Total
	Thru	Right	App. Total	Left	Thru	App. Total	Left	Right	App. Total	
04:30 PM	0	0	0	0	0	0	0	0	0	0
04:45 PM	0	0	0	0	0	0	0	0	0	0
05:00 PM	1	0	1	0	0	0	0	0	0	1
05:15 PM	0	0	0	0	0	0	0	0	0	0
Total Volume	1	0	1	0	0	0	0	0	0	1
% App. Total	100	0		0	0		0	0		
PHF	.250	.000	.250	.000	.000	.000	.000	.000	.000	.250

Peak Hour Analysis From 04:30 PM to 05:15 PM - Peak 1 of 1
 Peak Hour for Entire Intersection Begins at 04:30 PM

City of Riverside
 N/S: Sycamore Canyon Blvd
 E/W: Sierra Ridge Drive
 Weather: Clear

File Name : RIVSCSRPM
 Site Code : 06715392
 Start Date : 7/7/2015
 Page No : 1

Groups Printed- 4+ Axle Trucks

Start Time	Sycamore Canyon Blvd Southbound			Sycamore Canyon Blvd Northbound			Sierra Ridge Drive Eastbound			Int. Total
	Thru	Right	App. Total	Left	Thru	App. Total	Left	Right	App. Total	
04:00 PM	3	1	4	2	5	7	2	1	3	14
04:15 PM	3	0	3	0	3	3	0	0	0	6
04:30 PM	2	0	2	1	4	5	2	0	2	9
04:45 PM	1	0	1	0	5	5	0	0	0	6
Total	9	1	10	3	17	20	4	1	5	35
05:00 PM	4	1	5	0	3	3	0	1	1	9
05:15 PM	2	1	3	1	8	9	1	1	2	14
05:30 PM	1	0	1	0	3	3	1	0	1	5
05:45 PM	2	1	3	0	0	0	3	0	3	6
Total	9	3	12	1	14	15	5	2	7	34
Grand Total	18	4	22	4	31	35	9	3	12	69
Apprch %	81.8	18.2		11.4	88.6		75	25		
Total %	26.1	5.8	31.9	5.8	44.9	50.7	13	4.3	17.4	

Start Time	Sycamore Canyon Blvd Southbound			Sycamore Canyon Blvd Northbound			Sierra Ridge Drive Eastbound			Int. Total
	Thru	Right	App. Total	Left	Thru	App. Total	Left	Right	App. Total	
04:30 PM	2	0	2	1	4	5	2	0	2	9
04:45 PM	1	0	1	0	5	5	0	0	0	6
05:00 PM	4	1	5	0	3	3	0	1	1	9
05:15 PM	2	1	3	1	8	9	1	1	2	14
Total Volume	9	2	11	2	20	22	3	2	5	38
% App. Total	81.8	18.2		9.1	90.9		60	40		
PHF	.563	.500	.550	.500	.625	.611	.375	.500	.625	.679

Peak Hour Analysis From 04:30 PM to 05:15 PM - Peak 1 of 1
 Peak Hour for Entire Intersection Begins at 04:30 PM

City of Riverside
 N/S: Sycamore Canyon Blvd
 E/W: Sierra Ridge Drive
 Weather: Clear

File Name : RIVSCSRPM
 Site Code : 06715392
 Start Date : 7/7/2015
 Page No : 2

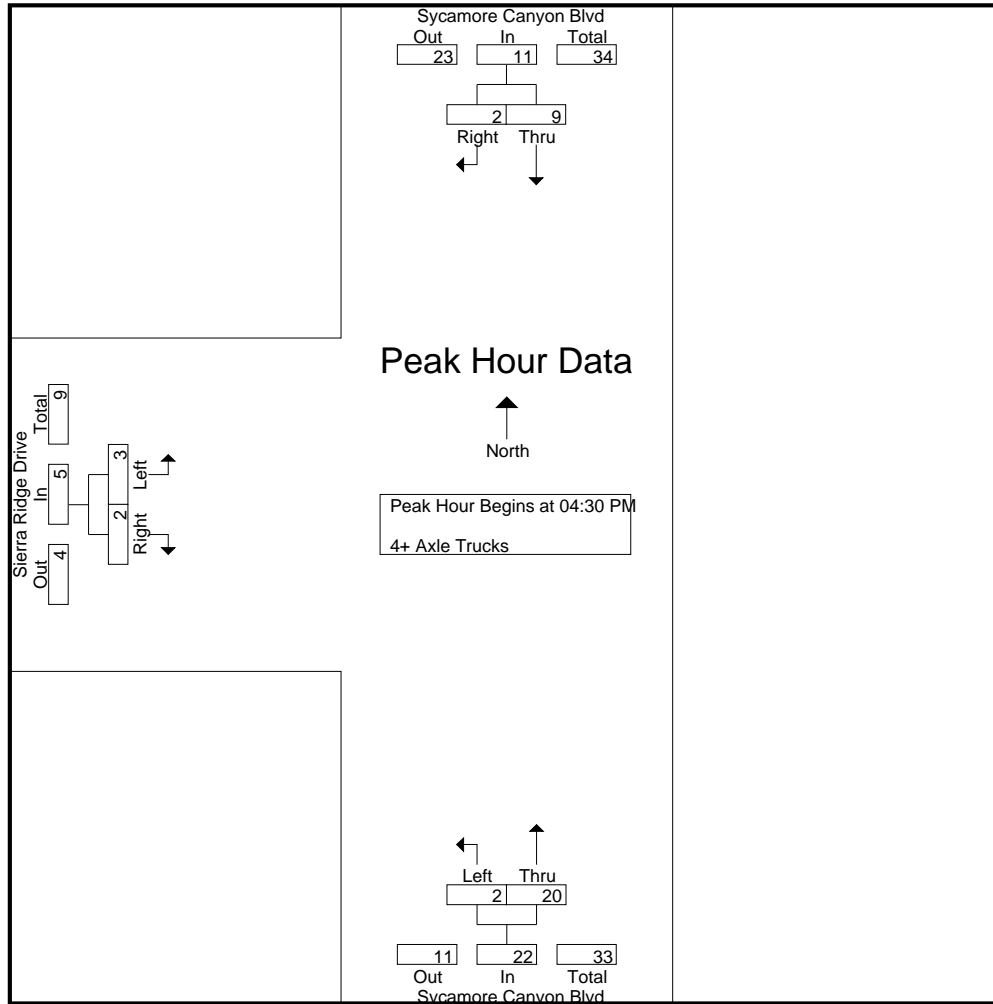

Peak Hour Analysis From 04:30 PM to 05:15 PM - Peak 1 of 1
 Peak Hour for Each Approach Begins at:

	04:30 PM			04:30 PM			04:30 PM		
+0 mins.	2	0	2	1	4	5	2	0	2
+15 mins.	1	0	1	0	5	5	0	0	0
+30 mins.	4	1	5	0	3	3	0	1	1
+45 mins.	2	1	3	1	8	9	1	1	2
Total Volume	9	2	11	2	20	22	3	2	5
% App. Total	81.8	18.2		9.1	90.9		60	40	
PHF	.563	.500	.550	.500	.625	.611	.375	.500	.625

Counts Unlimited Inc
 PO Box 1178
 Corona, CA 92878
 (951) 268-6268

City of Riverside
 N/S: Sycamore Canyon Blvd
 E/W: Eastridge Ave
 Weather: Clear

File Name : RIVSCERAM
 Site Code : 06715392
 Start Date : 7/7/2015
 Page No : 1

Groups Printed- Passenger Vehicles - Large 2 Axle Vehicles - 3 Axle Vehicles - 4+ Axle Trucks

Start Time	Sycamore Canyon Blvd Southbound				Eastridge Ave Westbound				Sycamore Canyon Blvd Northbound				Eastridge Ave Eastbound				Int. Total
	Left	Thru	Right	App. Total	Left	Thru	Right	App. Total	Left	Thru	Right	App. Total	Left	Thru	Right	App. Total	
07:00 AM	7	36	5	48	19	22	117	158	16	162	20	198	7	12	2	21	425
07:15 AM	13	27	12	52	30	24	112	166	17	187	26	230	7	7	2	16	464
07:30 AM	14	19	6	39	28	39	125	192	34	230	22	286	10	14	7	31	548
07:45 AM	29	22	11	62	24	32	115	171	62	198	33	293	7	13	7	27	553
Total	63	104	34	201	101	117	469	687	129	777	101	1007	31	46	18	95	1990
08:00 AM	24	17	7	48	20	39	97	156	19	147	24	190	9	14	2	25	419
08:15 AM	19	12	4	35	11	21	93	125	13	158	11	182	12	18	5	35	377
08:30 AM	30	31	5	66	14	17	69	100	15	147	20	182	10	18	6	34	382
08:45 AM	26	26	6	58	9	21	75	105	7	65	17	89	3	8	5	16	268
Total	99	86	22	207	54	98	334	486	54	517	72	643	34	58	18	110	1446
Grand Total	162	190	56	408	155	215	803	1173	183	1294	173	1650	65	104	36	205	3436
Apprch %	39.7	46.6	13.7		13.2	18.3	68.5		11.1	78.4	10.5		31.7	50.7	17.6		
Total %	4.7	5.5	1.6	11.9	4.5	6.3	23.4	34.1	5.3	37.7	5	48	1.9	3	1	6	
Passenger Vehicles	147	175	50	372	132	162	757	1051	174	1217	148	1539	36	55	26	117	3079
% Passenger Vehicles	90.7	92.1	89.3	91.2	85.2	75.3	94.3	89.6	95.1	94	85.5	93.3	55.4	52.9	72.2	57.1	89.6
Large 2 Axle Vehicles	7	9	1	17	4	10	13	27	0	24	7	31	3	5	5	13	88
% Large 2 Axle Vehicles	4.3	4.7	1.8	4.2	2.6	4.7	1.6	2.3	0	1.9	4	1.9	4.6	4.8	13.9	6.3	2.6
3 Axle Vehicles	1	1	1	3	2	3	5	10	1	5	3	9	1	2	1	4	26
% 3 Axle Vehicles	0.6	0.5	1.8	0.7	1.3	1.4	0.6	0.9	0.5	0.4	1.7	0.5	1.5	1.9	2.8	2	0.8
4+ Axle Trucks	7	5	4	16	17	40	28	85	8	48	15	71	25	42	4	71	243
% 4+ Axle Trucks	4.3	2.6	7.1	3.9	11	18.6	3.5	7.2	4.4	3.7	8.7	4.3	38.5	40.4	11.1	34.6	7.1

Start Time	Sycamore Canyon Blvd Southbound				Eastridge Ave Westbound				Sycamore Canyon Blvd Northbound				Eastridge Ave Eastbound				Int. Total
	Left	Thru	Right	App. Total	Left	Thru	Right	App. Total	Left	Thru	Right	App. Total	Left	Thru	Right	App. Total	
Peak Hour Analysis From 07:00 AM to 08:45 AM - Peak 1 of 1																	
Peak Hour for Entire Intersection Begins at 07:00 AM																	
07:00 AM	7	36	5	48	19	22	117	158	16	162	20	198	7	12	2	21	425
07:15 AM	13	27	12	52	30	24	112	166	17	187	26	230	7	7	2	16	464
07:30 AM	14	19	6	39	28	39	125	192	34	230	22	286	10	14	7	31	548
07:45 AM	29	22	11	62	24	32	115	171	62	198	33	293	7	13	7	27	553
Total Volume	63	104	34	201	101	117	469	687	129	777	101	1007	31	46	18	95	1990
% App. Total	31.3	51.7	16.9		14.7	17	68.3		12.8	77.2	10		32.6	48.4	18.9		
PHF	.543	.722	.708	.810	.842	.750	.938	.895	.520	.845	.765	.859	.775	.821	.643	.766	.900

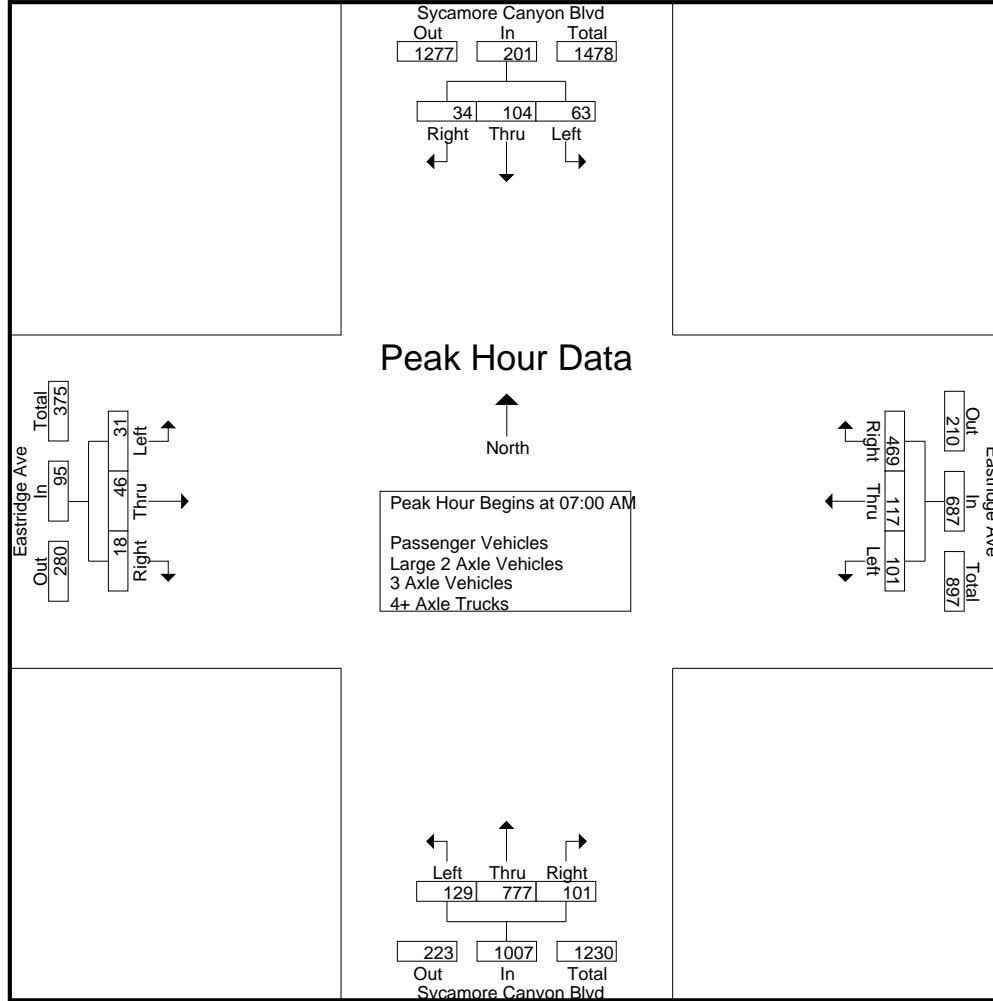

Peak Hour Analysis From 07:00 AM to 08:45 AM - Peak 1 of 1
 Peak Hour for Each Approach Begins at:

	07:45 AM				07:00 AM				07:00 AM				07:45 AM			
+0 mins.	29	22	11	62	19	22	117	158	16	162	20	198	7	13	7	27
+15 mins.	24	17	7	48	30	24	112	166	17	187	26	230	9	14	2	25
+30 mins.	19	12	4	35	28	39	125	192	34	230	22	286	12	18	5	35
+45 mins.	30	31	5	66	24	32	115	171	62	198	33	293	10	18	6	34
Total Volume	102	82	27	211	101	117	469	687	129	777	101	1007	38	63	20	121
% App. Total	48.3	38.9	12.8		14.7	17	68.3		12.8	77.2	10		31.4	52.1	16.5	
PHF	.850	.661	.614	.799	.842	.750	.938	.895	.520	.845	.765	.859	.792	.875	.714	.864

Counts Unlimited Inc
 PO Box 1178
 Corona, CA 92878
 (951) 268-6268

City of Riverside
 N/S: Sycamore Canyon Blvd
 E/W: Eastridge Ave
 Weather: Clear

File Name : RIVSCERAM
 Site Code : 06715392
 Start Date : 7/7/2015
 Page No : 1

Groups Printed- Passenger Vehicles

Start Time	Sycamore Canyon Blvd Southbound				Eastridge Ave Westbound				Sycamore Canyon Blvd Northbound				Eastridge Ave Eastbound				Int. Total
	Left	Thru	Right	App. Total	Left	Thru	Right	App. Total	Left	Thru	Right	App. Total	Left	Thru	Right	App. Total	
07:00 AM	6	33	4	43	17	13	114	144	15	154	16	185	4	8	0	12	384
07:15 AM	12	22	12	46	23	15	103	141	16	177	23	216	2	4	1	7	410
07:30 AM	12	19	4	35	25	34	121	180	31	216	19	266	7	8	5	20	501
07:45 AM	27	22	10	59	22	27	108	157	61	189	28	278	4	4	4	12	506
Total	57	96	30	183	87	89	446	622	123	736	86	945	17	24	10	51	1801
08:00 AM	21	15	7	43	15	31	93	139	18	138	20	176	3	6	2	11	369
08:15 AM	17	12	4	33	10	16	86	112	12	147	8	167	9	11	4	24	336
08:30 AM	29	30	4	63	13	12	66	91	14	138	19	171	4	10	6	20	345
08:45 AM	23	22	5	50	7	14	66	87	7	58	15	80	3	4	4	11	228
Total	90	79	20	189	45	73	311	429	51	481	62	594	19	31	16	66	1278
Grand Total	147	175	50	372	132	162	757	1051	174	1217	148	1539	36	55	26	117	3079
Apprch %	39.5	47	13.4		12.6	15.4	72		11.3	79.1	9.6		30.8	47	22.2		
Total %	4.8	5.7	1.6	12.1	4.3	5.3	24.6	34.1	5.7	39.5	4.8	50	1.2	1.8	0.8	3.8	

Start Time	Sycamore Canyon Blvd Southbound				Eastridge Ave Westbound				Sycamore Canyon Blvd Northbound				Eastridge Ave Eastbound				Int. Total
	Left	Thru	Right	App. Total	Left	Thru	Right	App. Total	Left	Thru	Right	App. Total	Left	Thru	Right	App. Total	
Peak Hour Analysis From 07:00 AM to 07:45 AM - Peak 1 of 1																	
Peak Hour for Entire Intersection Begins at 07:00 AM																	
07:00 AM	6	33	4	43	17	13	114	144	15	154	16	185	4	8	0	12	384
07:15 AM	12	22	12	46	23	15	103	141	16	177	23	216	2	4	1	7	410
07:30 AM	12	19	4	35	25	34	121	180	31	216	19	266	7	8	5	20	501
07:45 AM	27	22	10	59	22	27	108	157	61	189	28	278	4	4	4	12	506
Total Volume	57	96	30	183	87	89	446	622	123	736	86	945	17	24	10	51	1801
% App. Total	31.1	52.5	16.4		14	14.3	71.7		13	77.9	9.1		33.3	47.1	19.6		
PHF	.528	.727	.625	.775	.870	.654	.921	.864	.504	.852	.768	.850	.607	.750	.500	.638	.890

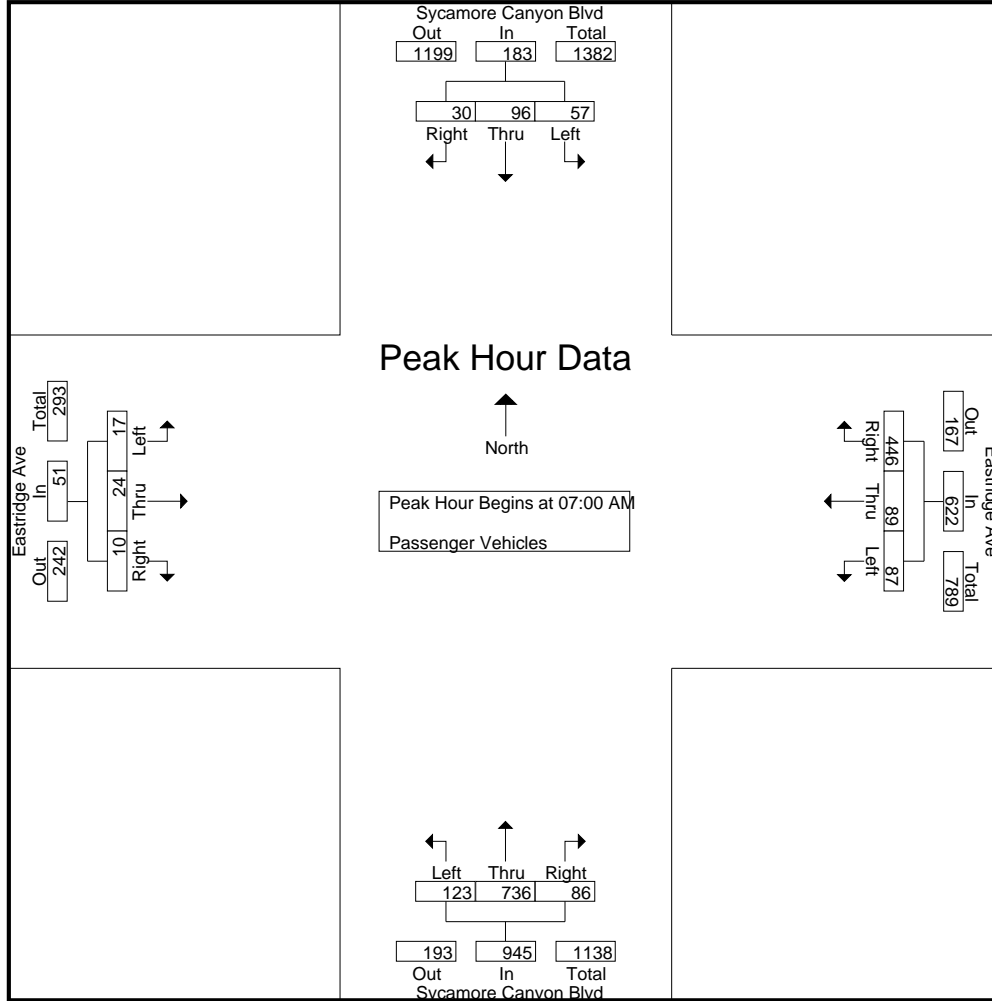

Peak Hour Analysis From 07:00 AM to 07:45 AM - Peak 1 of 1
 Peak Hour for Each Approach Begins at:

	07:00 AM				07:00 AM				07:00 AM				07:00 AM			
+0 mins.	6	33	4	43	17	13	114	144	15	154	16	185	4	8	0	12
+15 mins.	12	22	12	46	23	15	103	141	16	177	23	216	2	4	1	7
+30 mins.	12	19	4	35	25	34	121	180	31	216	19	266	7	8	5	20
+45 mins.	27	22	10	59	22	27	108	157	61	189	28	278	4	4	4	12
Total Volume	57	96	30	183	87	89	446	622	123	736	86	945	17	24	10	51
% App. Total	31.1	52.5	16.4		14	14.3	71.7		13	77.9	9.1		33.3	47.1	19.6	
PHF	.528	.727	.625	.775	.870	.654	.921	.864	.504	.852	.768	.850	.607	.750	.500	.638

Counts Unlimited Inc
PO Box 1178
Corona, CA 92878
(951) 268-6268

City of Riverside
N/S: Sycamore Canyon Blvd
E/W: Eastridge Ave
Weather: Clear

File Name : RIVSCERAM
Site Code : 06715392
Start Date : 7/7/2015
Page No : 1

Groups Printed- Large 2 Axle Vehicles

Start Time	Sycamore Canyon Blvd Southbound				Eastridge Ave Westbound				Sycamore Canyon Blvd Northbound				Eastridge Ave Eastbound				Int. Total
	Left	Thru	Right	App. Total	Left	Thru	Right	App. Total	Left	Thru	Right	App. Total	Left	Thru	Right	App. Total	
07:00 AM	0	1	0	1	1	0	0	1	0	3	2	5	1	1	2	4	11
07:15 AM	0	4	0	4	0	3	1	4	0	2	0	2	1	1	0	2	12
07:30 AM	2	0	0	2	0	0	2	2	0	6	0	6	1	1	0	2	12
07:45 AM	1	0	0	1	2	0	1	3	0	1	1	2	0	0	1	1	7
Total	3	5	0	8	3	3	4	10	0	12	3	15	3	3	3	9	42
08:00 AM	1	1	0	2	1	2	2	5	0	4	1	5	0	0	0	0	12
08:15 AM	2	0	0	2	0	2	1	3	0	2	0	2	0	1	1	2	9
08:30 AM	0	1	0	1	0	1	1	2	0	3	1	4	0	1	0	1	8
08:45 AM	1	2	1	4	0	2	5	7	0	3	2	5	0	0	1	1	17
Total	4	4	1	9	1	7	9	17	0	12	4	16	0	2	2	4	46
Grand Total	7	9	1	17	4	10	13	27	0	24	7	31	3	5	5	13	88
Apprch %	41.2	52.9	5.9		14.8	37	48.1		0	77.4	22.6		23.1	38.5	38.5		
Total %	8	10.2	1.1	19.3	4.5	11.4	14.8	30.7	0	27.3	8	35.2	3.4	5.7	5.7	14.8	

Start Time	Sycamore Canyon Blvd Southbound				Eastridge Ave Westbound				Sycamore Canyon Blvd Northbound				Eastridge Ave Eastbound				Int. Total
	Left	Thru	Right	App. Total	Left	Thru	Right	App. Total	Left	Thru	Right	App. Total	Left	Thru	Right	App. Total	
Peak Hour Analysis From 07:00 AM to 07:45 AM - Peak 1 of 1																	
Peak Hour for Entire Intersection Begins at 07:00 AM																	
07:00 AM	0	1	0	1	1	0	0	1	0	3	2	5	1	1	2	4	11
07:15 AM	0	4	0	4	0	3	1	4	0	2	0	2	1	1	0	2	12
07:30 AM	2	0	0	2	0	0	2	2	0	6	0	6	1	1	0	2	12
07:45 AM	1	0	0	1	2	0	1	3	0	1	1	2	0	0	1	1	7
Total Volume	3	5	0	8	3	3	4	10	0	12	3	15	3	3	3	9	42
% App. Total	37.5	62.5	0		30	30	40		0	80	20		33.3	33.3	33.3		
PHF	.375	.313	.000	.500	.375	.250	.500	.625	.000	.500	.375	.625	.750	.750	.375	.563	.875

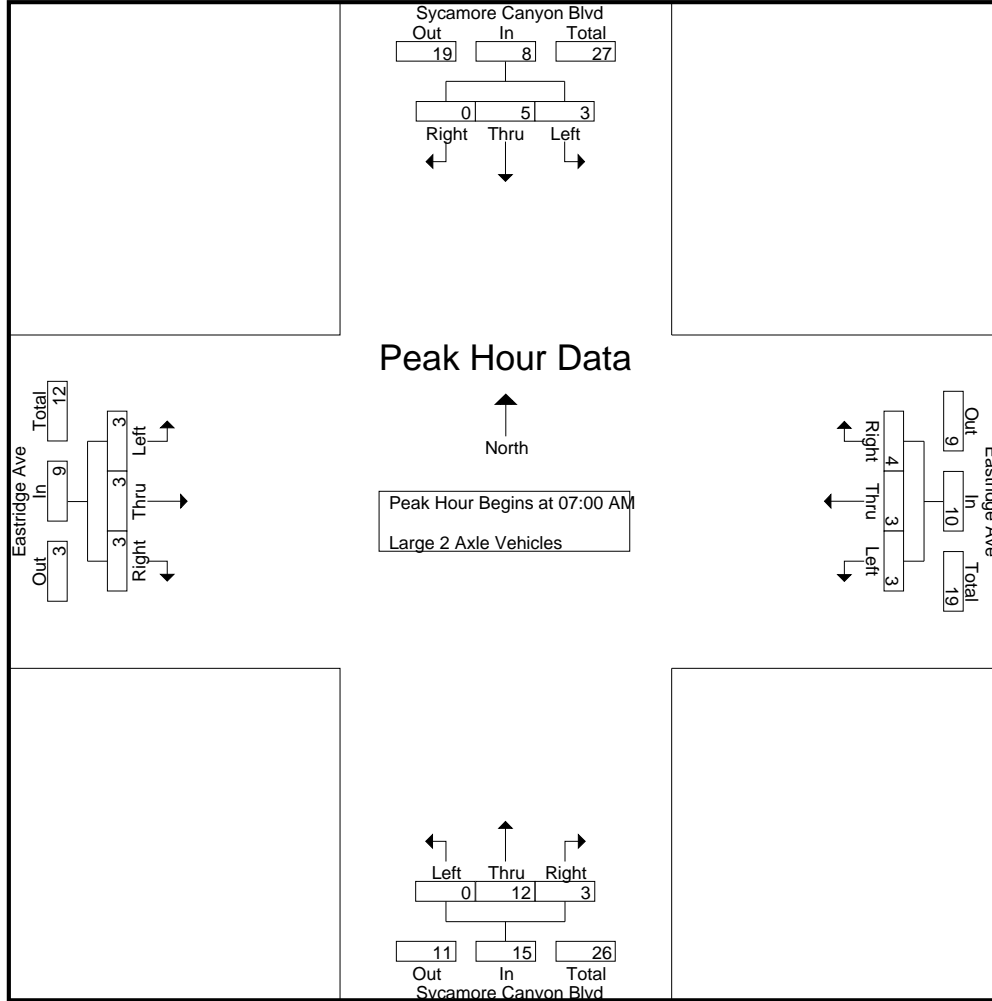

Peak Hour Analysis From 07:00 AM to 07:45 AM - Peak 1 of 1
 Peak Hour for Each Approach Begins at:

	07:00 AM				07:00 AM				07:00 AM				07:00 AM			
+0 mins.	0	1	0	1	1	0	0	1	0	3	2	5	1	1	2	4
+15 mins.	0	4	0	4	0	3	1	4	0	2	0	2	1	1	0	2
+30 mins.	2	0	0	2	0	0	2	2	0	6	0	6	1	1	0	2
+45 mins.	1	0	0	1	2	0	1	3	0	1	1	2	0	0	1	1
Total Volume	3	5	0	8	3	3	4	10	0	12	3	15	3	3	3	9
% App. Total	37.5	62.5	0		30	30	40		0	80	20		33.3	33.3	33.3	
PHF	.375	.313	.000	.500	.375	.250	.500	.625	.000	.500	.375	.625	.750	.750	.375	.563

Counts Unlimited Inc
PO Box 1178
Corona, CA 92878
(951) 268-6268

City of Riverside
N/S: Sycamore Canyon Blvd
E/W: Eastridge Ave
Weather: Clear

File Name : RIVSCERAM
Site Code : 06715392
Start Date : 7/7/2015
Page No : 1

Groups Printed- 3 Axle Vehicles

Start Time	Sycamore Canyon Blvd Southbound				Eastridge Ave Westbound				Sycamore Canyon Blvd Northbound				Eastridge Ave Eastbound				Int. Total
	Left	Thru	Right	App. Total	Left	Thru	Right	App. Total	Left	Thru	Right	App. Total	Left	Thru	Right	App. Total	
07:00 AM	0	1	0	1	0	1	0	1	0	0	0	0	0	0	0	0	2
07:15 AM	0	0	0	0	1	0	0	1	0	1	1	2	0	0	0	0	3
07:30 AM	0	0	0	0	0	1	0	1	1	0	0	1	0	0	0	0	2
07:45 AM	0	0	1	1	0	0	4	4	0	0	1	1	0	0	1	1	7
Total	0	1	1	2	1	2	4	7	1	1	2	4	0	0	1	1	14
08:00 AM	0	0	0	0	1	0	0	1	0	1	1	2	0	2	0	2	5
08:15 AM	0	0	0	0	0	1	1	2	0	2	0	2	0	0	0	0	4
08:30 AM	1	0	0	1	0	0	0	0	0	1	0	1	1	0	0	1	3
08:45 AM	0	0	0	0	0	0	0	0	0	0	0	0	0	0	0	0	0
Total	1	0	0	1	1	1	1	3	0	4	1	5	1	2	0	3	12
Grand Total	1	1	1	3	2	3	5	10	1	5	3	9	1	2	1	4	26
Apprch %	33.3	33.3	33.3		20	30	50		11.1	55.6	33.3		25	50	25		
Total %	3.8	3.8	3.8	11.5	7.7	11.5	19.2	38.5	3.8	19.2	11.5	34.6	3.8	7.7	3.8	15.4	

Start Time	Sycamore Canyon Blvd Southbound				Eastridge Ave Westbound				Sycamore Canyon Blvd Northbound				Eastridge Ave Eastbound				Int. Total
	Left	Thru	Right	App. Total	Left	Thru	Right	App. Total	Left	Thru	Right	App. Total	Left	Thru	Right	App. Total	
Peak Hour Analysis From 07:00 AM to 07:45 AM - Peak 1 of 1																	
Peak Hour for Entire Intersection Begins at 07:00 AM																	
07:00 AM	0	1	0	1	0	1	0	1	0	0	0	0	0	0	0	0	2
07:15 AM	0	0	0	0	1	0	0	1	0	1	1	2	0	0	0	0	3
07:30 AM	0	0	0	0	0	1	0	1	1	0	0	1	0	0	0	0	2
07:45 AM	0	0	1	1	0	0	4	4	0	0	1	1	0	0	1	1	7
Total Volume	0	1	1	2	1	2	4	7	1	1	2	4	0	0	1	1	14
% App. Total	0	50	50		14.3	28.6	57.1		25	25	50		0	0	100		
PHF	.000	.250	.250	.500	.250	.500	.250	.438	.250	.250	.500	.500	.000	.000	.250	.250	.500

City of Riverside
 N/S: Sycamore Canyon Blvd
 E/W: Eastridge Ave
 Weather: Clear

File Name : RIVSCERAM
 Site Code : 06715392
 Start Date : 7/7/2015
 Page No : 2

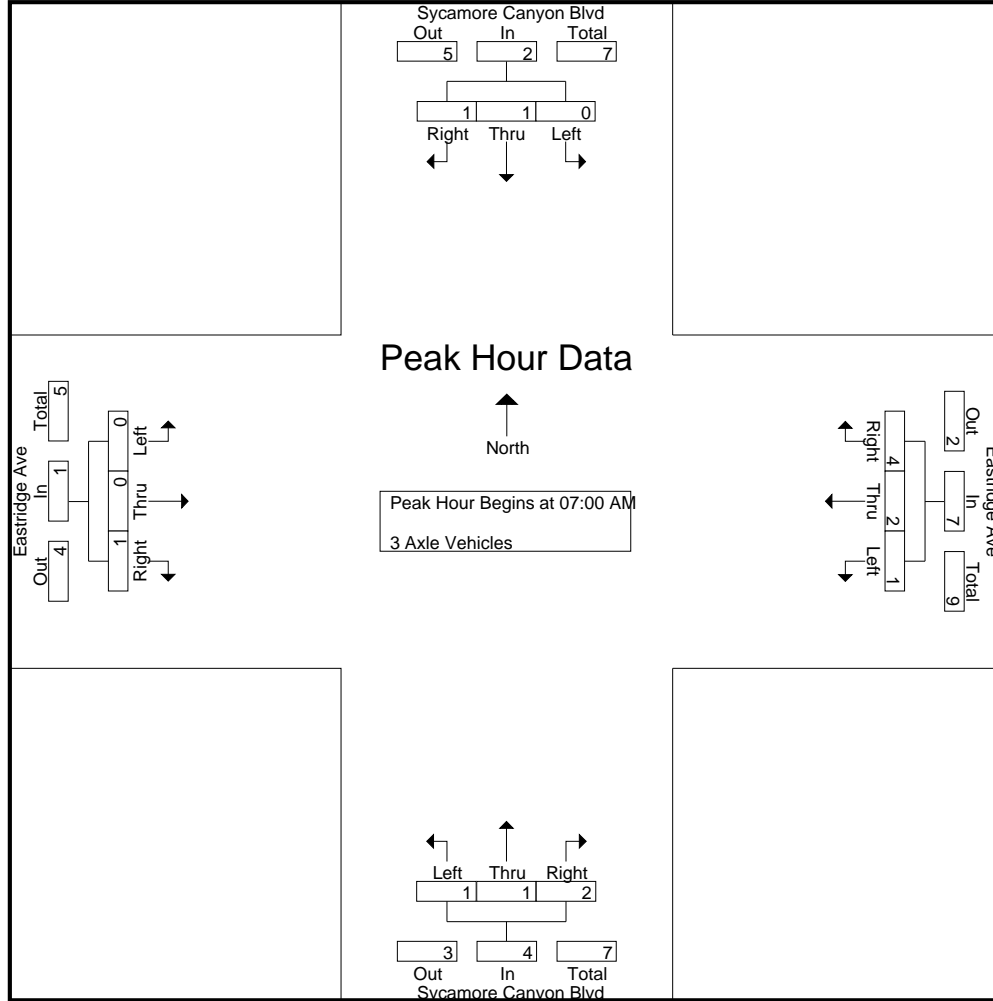

Peak Hour Analysis From 07:00 AM to 07:45 AM - Peak 1 of 1
 Peak Hour for Each Approach Begins at:

	07:00 AM				07:00 AM				07:00 AM				07:00 AM			
+0 mins.	0	1	0	1	0	1	0	1	0	0	0	0	0	0	0	0
+15 mins.	0	0	0	0	1	0	0	1	0	1	1	2	0	0	0	0
+30 mins.	0	0	0	0	0	1	0	1	1	0	0	1	0	0	0	0
+45 mins.	0	0	1	1	0	0	4	4	0	0	1	1	0	0	1	1
Total Volume	0	1	1	2	1	2	4	7	1	1	2	4	0	0	1	1
% App. Total	0	50	50		14.3	28.6	57.1		25	25	50		0	0	100	
PHF	.000	.250	.250	.500	.250	.500	.250	.438	.250	.250	.500	.500	.000	.000	.250	.250

Counts Unlimited Inc
PO Box 1178
Corona, CA 92878
(951) 268-6268

City of Riverside
N/S: Sycamore Canyon Blvd
E/W: Eastridge Ave
Weather: Clear

File Name : RIVSCERAM
Site Code : 06715392
Start Date : 7/7/2015
Page No : 1

Groups Printed- 4+ Axle Trucks

Start Time	Sycamore Canyon Blvd Southbound				Eastridge Ave Westbound				Sycamore Canyon Blvd Northbound				Eastridge Ave Eastbound				Int. Total
	Left	Thru	Right	App. Total	Left	Thru	Right	App. Total	Left	Thru	Right	App. Total	Left	Thru	Right	App. Total	
07:00 AM	1	1	1	3	1	8	3	12	1	5	2	8	2	3	0	5	28
07:15 AM	1	1	0	2	6	6	8	20	1	7	2	10	4	2	1	7	39
07:30 AM	0	0	2	2	3	4	2	9	2	8	3	13	2	5	2	9	33
07:45 AM	1	0	0	1	0	5	2	7	1	8	3	12	3	9	1	13	33
Total	3	2	3	8	10	23	15	48	5	28	10	43	11	19	4	34	133
08:00 AM	2	1	0	3	3	6	2	11	1	4	2	7	6	6	0	12	33
08:15 AM	0	0	0	0	1	2	5	8	1	7	3	11	3	6	0	9	28
08:30 AM	0	0	1	1	1	4	2	7	1	5	0	6	5	7	0	12	26
08:45 AM	2	2	0	4	2	5	4	11	0	4	0	4	0	4	0	4	23
Total	4	3	1	8	7	17	13	37	3	20	5	28	14	23	0	37	110
Grand Total	7	5	4	16	17	40	28	85	8	48	15	71	25	42	4	71	243
Apprch %	43.8	31.2	25		20	47.1	32.9		11.3	67.6	21.1		35.2	59.2	5.6		
Total %	2.9	2.1	1.6	6.6	7	16.5	11.5	35	3.3	19.8	6.2	29.2	10.3	17.3	1.6	29.2	

Start Time	Sycamore Canyon Blvd Southbound				Eastridge Ave Westbound				Sycamore Canyon Blvd Northbound				Eastridge Ave Eastbound				Int. Total
	Left	Thru	Right	App. Total	Left	Thru	Right	App. Total	Left	Thru	Right	App. Total	Left	Thru	Right	App. Total	
Peak Hour Analysis From 07:00 AM to 07:45 AM - Peak 1 of 1																	
Peak Hour for Entire Intersection Begins at 07:00 AM																	
07:00 AM	1	1	1	3	1	8	3	12	1	5	2	8	2	3	0	5	28
07:15 AM	1	1	0	2	6	6	8	20	1	7	2	10	4	2	1	7	39
07:30 AM	0	0	2	2	3	4	2	9	2	8	3	13	2	5	2	9	33
07:45 AM	1	0	0	1	0	5	2	7	1	8	3	12	3	9	1	13	33
Total Volume	3	2	3	8	10	23	15	48	5	28	10	43	11	19	4	34	133
% App. Total	37.5	25	37.5		20.8	47.9	31.2		11.6	65.1	23.3		32.4	55.9	11.8		
PHF	.750	.500	.375	.667	.417	.719	.469	.600	.625	.875	.833	.827	.688	.528	.500	.654	.853

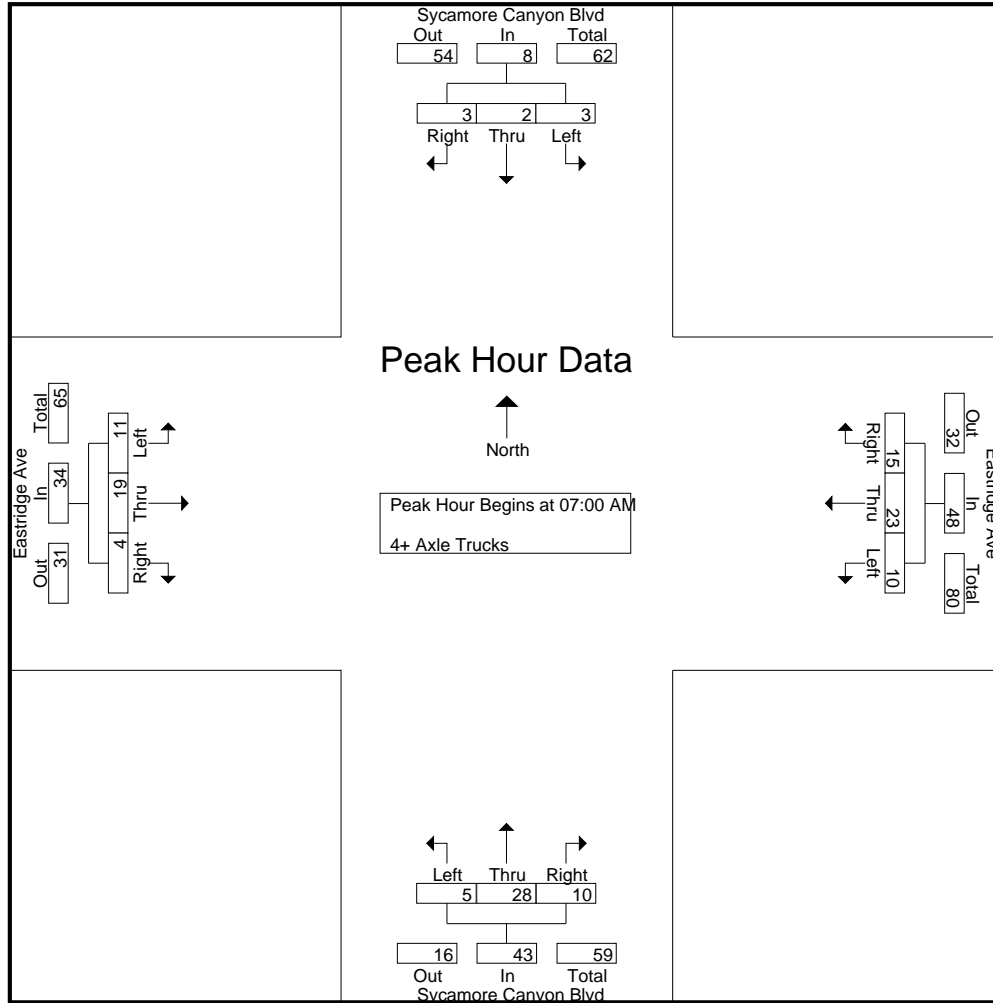

Peak Hour Analysis From 07:00 AM to 07:45 AM - Peak 1 of 1
 Peak Hour for Each Approach Begins at:

	07:00 AM				07:00 AM				07:00 AM				07:00 AM			
+0 mins.	1	1	1	3	1	8	3	12	1	5	2	8	2	3	0	5
+15 mins.	1	1	0	2	6	6	8	20	1	7	2	10	4	2	1	7
+30 mins.	0	0	2	2	3	4	2	9	2	8	3	13	2	5	2	9
+45 mins.	1	0	0	1	0	5	2	7	1	8	3	12	3	9	1	13
Total Volume	3	2	3	8	10	23	15	48	5	28	10	43	11	19	4	34
% App. Total	37.5	25	37.5		20.8	47.9	31.2		11.6	65.1	23.3		32.4	55.9	11.8	
PHF	.750	.500	.375	.667	.417	.719	.469	.600	.625	.875	.833	.827	.688	.528	.500	.654

Counts Unlimited Inc
PO Box 1178
Corona, CA 92878
(951) 268-6268

City of Riverside
N/S: Sycamore Canyon Blvd
E/W: Eastridge Ave
Weather: Clear

File Name : RIVSCERPM
Site Code : 06715392
Start Date : 7/7/2015
Page No : 1

Groups Printed- Passenger Vehicles - Large 2 Axle Vehicles - 3 Axle Vehicles - 4+ Axle Trucks

Start Time	Sycamore Canyon Blvd Southbound				Eastridge Ave Westbound				Sycamore Canyon Blvd Northbound				Eastridge Ave Eastbound				Int. Total
	Left	Thru	Right	App. Total	Left	Thru	Right	App. Total	Left	Thru	Right	App. Total	Left	Thru	Right	App. Total	
04:00 PM	83	66	11	160	34	16	58	108	10	49	27	86	22	44	18	84	438
04:15 PM	56	40	1	97	21	12	56	89	7	44	30	81	11	23	10	44	311
04:30 PM	68	63	6	137	52	10	57	119	7	53	32	92	17	35	11	63	411
04:45 PM	56	60	3	119	32	16	56	104	8	43	25	76	10	27	8	45	344
Total	263	229	21	513	139	54	227	420	32	189	114	335	60	129	47	236	1504
05:00 PM	94	93	1	188	45	13	38	96	11	53	40	104	21	38	28	87	475
05:15 PM	58	99	2	159	32	18	42	92	8	50	21	79	14	22	13	49	379
05:30 PM	47	60	3	110	40	17	29	86	7	32	17	56	8	19	5	32	284
05:45 PM	34	53	6	93	32	18	33	83	7	40	13	60	10	13	10	33	269
Total	233	305	12	550	149	66	142	357	33	175	91	299	53	92	56	201	1407
Grand Total	496	534	33	1063	288	120	369	777	65	364	205	634	113	221	103	437	2911
Apprch %	46.7	50.2	3.1		37.1	15.4	47.5		10.3	57.4	32.3		25.9	50.6	23.6		
Total %	17	18.3	1.1	36.5	9.9	4.1	12.7	26.7	2.2	12.5	7	21.8	3.9	7.6	3.5	15	
Passenger Vehicles	486	525	20	1031	280	78	346	704	59	352	188	599	94	168	98	360	2694
% Passenger Vehicles	98	98.3	60.6	97	97.2	65	93.8	90.6	90.8	96.7	91.7	94.5	83.2	76	95.1	82.4	92.5
Large 2 Axle Vehicles	1	4	8	13	2	8	9	19	3	2	2	7	6	5	2	13	52
% Large 2 Axle Vehicles	0.2	0.7	24.2	1.2	0.7	6.7	2.4	2.4	4.6	0.5	1	1.1	5.3	2.3	1.9	3	1.8
3 Axle Vehicles	3	2	1	6	0	2	7	9	1	3	0	4	1	2	1	4	23
% 3 Axle Vehicles	0.6	0.4	3	0.6	0	1.7	1.9	1.2	1.5	0.8	0	0.6	0.9	0.9	1	0.9	0.8
4+ Axle Trucks	6	3	4	13	6	32	7	45	2	7	15	24	12	46	2	60	142
% 4+ Axle Trucks	1.2	0.6	12.1	1.2	2.1	26.7	1.9	5.8	3.1	1.9	7.3	3.8	10.6	20.8	1.9	13.7	4.9

Start Time	Sycamore Canyon Blvd Southbound				Eastridge Ave Westbound				Sycamore Canyon Blvd Northbound				Eastridge Ave Eastbound				Int. Total
	Left	Thru	Right	App. Total	Left	Thru	Right	App. Total	Left	Thru	Right	App. Total	Left	Thru	Right	App. Total	
Peak Hour Analysis From 04:00 PM to 05:45 PM - Peak 1 of 1																	
Peak Hour for Entire Intersection Begins at 04:30 PM																	
04:30 PM	68	63	6	137	52	10	57	119	7	53	32	92	17	35	11	63	411
04:45 PM	56	60	3	119	32	16	56	104	8	43	25	76	10	27	8	45	344
05:00 PM	94	93	1	188	45	13	38	96	11	53	40	104	21	38	28	87	475
05:15 PM	58	99	2	159	32	18	42	92	8	50	21	79	14	22	13	49	379
Total Volume	276	315	12	603	161	57	193	411	34	199	118	351	62	122	60	244	1609
% App. Total	45.8	52.2	2		39.2	13.9	47		9.7	56.7	33.6		25.4	50	24.6		
PHF	.734	.795	.500	.802	.774	.792	.846	.863	.773	.939	.738	.844	.738	.803	.536	.701	.847

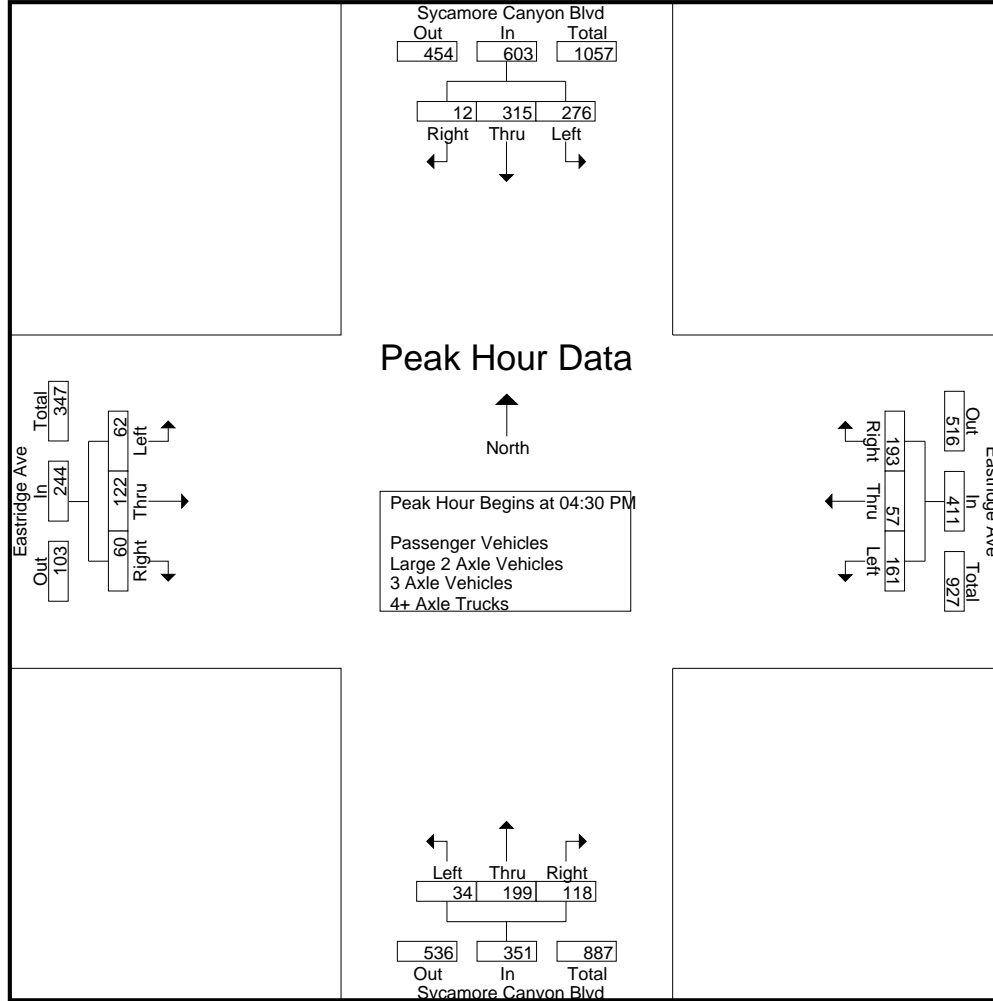

Peak Hour Analysis From 04:00 PM to 05:45 PM - Peak 1 of 1
 Peak Hour for Each Approach Begins at:

	04:30 PM				04:00 PM				04:15 PM				04:30 PM			
+0 mins.	68	63	6	137	34	16	58	108	7	44	30	81	17	35	11	63
+15 mins.	56	60	3	119	21	12	56	89	7	53	32	92	10	27	8	45
+30 mins.	94	93	1	188	52	10	57	119	8	43	25	76	21	38	28	87
+45 mins.	58	99	2	159	32	16	56	104	11	53	40	104	14	22	13	49
Total Volume	276	315	12	603	139	54	227	420	33	193	127	353	62	122	60	244
% App. Total	45.8	52.2	2		33.1	12.9	54		9.3	54.7	36		25.4	50	24.6	
PHF	.734	.795	.500	.802	.668	.844	.978	.882	.750	.910	.794	.849	.738	.803	.536	.701

Counts Unlimited Inc
PO Box 1178
Corona, CA 92878
(951) 268-6268

City of Riverside
 N/S: Sycamore Canyon Blvd
 E/W: Eastridge Ave
 Weather: Clear

File Name : RIVSCERPM
 Site Code : 06715392
 Start Date : 7/7/2015
 Page No : 1

Groups Printed- Passenger Vehicles

Start Time	Sycamore Canyon Blvd Southbound				Eastridge Ave Westbound				Sycamore Canyon Blvd Northbound				Eastridge Ave Eastbound				Int. Total
	Left	Thru	Right	App. Total	Left	Thru	Right	App. Total	Left	Thru	Right	App. Total	Left	Thru	Right	App. Total	
04:00 PM	82	65	7	154	34	9	54	97	8	48	25	81	19	34	18	71	403
04:15 PM	56	40	1	97	18	5	56	79	7	41	28	76	10	15	10	35	287
04:30 PM	68	63	3	134	51	7	55	113	7	51	28	86	15	26	10	51	384
04:45 PM	53	58	1	112	31	10	50	91	6	43	22	71	8	22	7	37	311
Total	259	226	12	497	134	31	215	380	28	183	103	314	52	97	45	194	1385
05:00 PM	93	92	0	185	45	10	38	93	10	52	36	98	19	34	27	80	456
05:15 PM	56	97	1	154	32	11	39	82	8	47	20	75	11	18	11	40	351
05:30 PM	44	57	3	104	38	13	27	78	6	30	17	53	5	10	5	20	255
05:45 PM	34	53	4	91	31	13	27	71	7	40	12	59	7	9	10	26	247
Total	227	299	8	534	146	47	131	324	31	169	85	285	42	71	53	166	1309
Grand Total	486	525	20	1031	280	78	346	704	59	352	188	599	94	168	98	360	2694
Apprch %	47.1	50.9	1.9		39.8	11.1	49.1		9.8	58.8	31.4		26.1	46.7	27.2		
Total %	18	19.5	0.7	38.3	10.4	2.9	12.8	26.1	2.2	13.1	7	22.2	3.5	6.2	3.6	13.4	

Start Time	Sycamore Canyon Blvd Southbound				Eastridge Ave Westbound				Sycamore Canyon Blvd Northbound				Eastridge Ave Eastbound				Int. Total
	Left	Thru	Right	App. Total	Left	Thru	Right	App. Total	Left	Thru	Right	App. Total	Left	Thru	Right	App. Total	
Peak Hour Analysis From 04:30 PM to 05:15 PM - Peak 1 of 1																	
Peak Hour for Entire Intersection Begins at 04:30 PM																	
04:30 PM	68	63	3	134	51	7	55	113	7	51	28	86	15	26	10	51	384
04:45 PM	53	58	1	112	31	10	50	91	6	43	22	71	8	22	7	37	311
05:00 PM	93	92	0	185	45	10	38	93	10	52	36	98	19	34	27	80	456
05:15 PM	56	97	1	154	32	11	39	82	8	47	20	75	11	18	11	40	351
Total Volume	270	310	5	585	159	38	182	379	31	193	106	330	53	100	55	208	1502
% App. Total	46.2	53	0.9		42	10	48		9.4	58.5	32.1		25.5	48.1	26.4		
PHF	.726	.799	.417	.791	.779	.864	.827	.838	.775	.928	.736	.842	.697	.735	.509	.650	.823

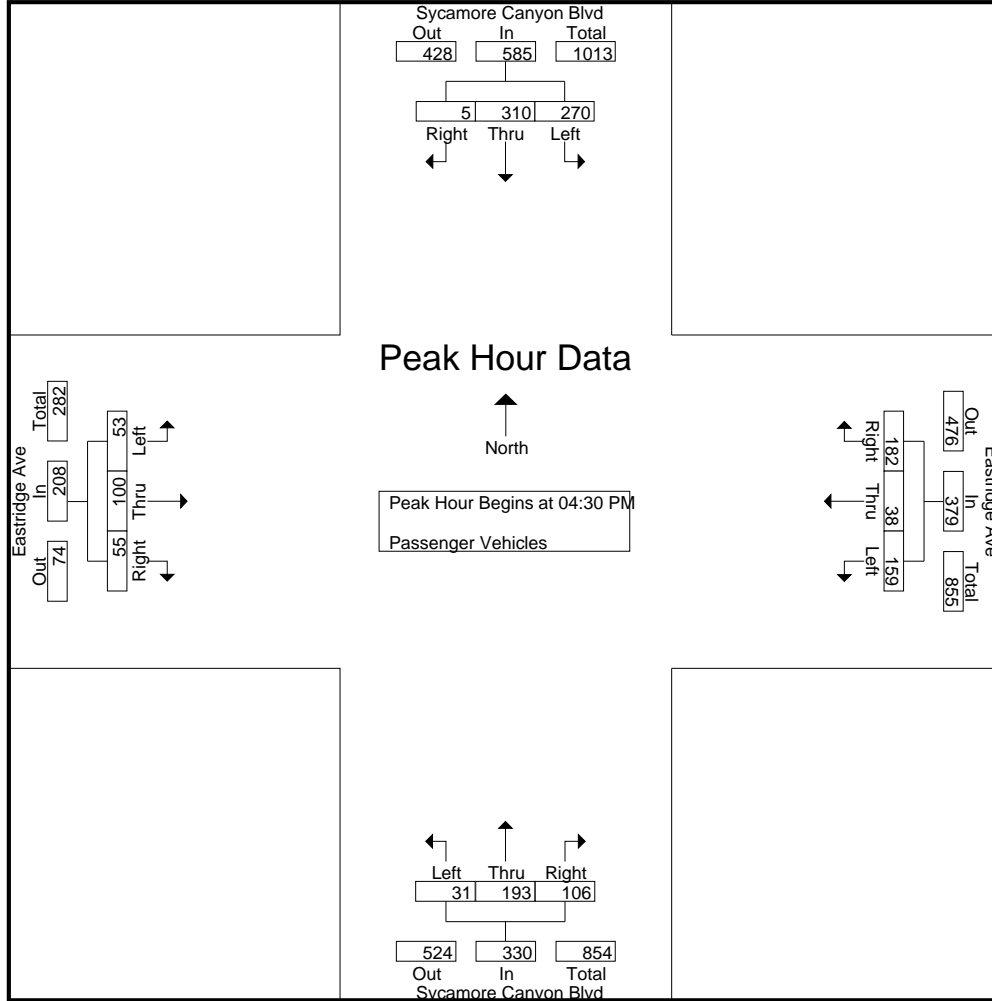

Peak Hour Analysis From 04:30 PM to 05:15 PM - Peak 1 of 1
 Peak Hour for Each Approach Begins at:

	04:30 PM				04:30 PM				04:30 PM				04:30 PM			
+0 mins.	68	63	3	134	51	7	55	113	7	51	28	86	15	26	10	51
+15 mins.	53	58	1	112	31	10	50	91	6	43	22	71	8	22	7	37
+30 mins.	93	92	0	185	45	10	38	93	10	52	36	98	19	34	27	80
+45 mins.	56	97	1	154	32	11	39	82	8	47	20	75	11	18	11	40
Total Volume	270	310	5	585	159	38	182	379	31	193	106	330	53	100	55	208
% App. Total	46.2	53	0.9		42	10	48		9.4	58.5	32.1		25.5	48.1	26.4	
PHF	.726	.799	.417	.791	.779	.864	.827	.838	.775	.928	.736	.842	.697	.735	.509	.650

Counts Unlimited Inc
 PO Box 1178
 Corona, CA 92878
 (951) 268-6268

City of Riverside
 N/S: Sycamore Canyon Blvd
 E/W: Eastridge Ave
 Weather: Clear

File Name : RIVSCERPM
 Site Code : 06715392
 Start Date : 7/7/2015
 Page No : 1

Groups Printed- Large 2 Axle Vehicles

Start Time	Sycamore Canyon Blvd Southbound				Eastridge Ave Westbound				Sycamore Canyon Blvd Northbound				Eastridge Ave Eastbound				Int. Total
	Left	Thru	Right	App. Total	Left	Thru	Right	App. Total	Left	Thru	Right	App. Total	Left	Thru	Right	App. Total	
04:00 PM	1	1	3	5	0	2	2	4	2	1	0	3	0	0	0	0	12
04:15 PM	0	0	0	0	2	2	0	4	0	0	0	0	0	1	0	1	5
04:30 PM	0	0	0	0	0	1	0	1	0	0	1	1	1	2	1	4	6
04:45 PM	0	1	2	3	0	0	2	2	0	0	1	1	1	0	1	2	8
Total	1	2	5	8	2	5	4	11	2	1	2	5	2	3	2	7	31
05:00 PM	0	0	0	0	0	0	0	0	1	0	0	1	0	0	0	0	1
05:15 PM	0	0	1	1	0	2	1	3	0	0	0	0	1	1	0	2	6
05:30 PM	0	2	0	2	0	1	2	3	0	1	0	1	2	1	0	3	9
05:45 PM	0	0	2	2	0	0	2	2	0	0	0	0	1	0	0	1	5
Total	0	2	3	5	0	3	5	8	1	1	0	2	4	2	0	6	21
Grand Total	1	4	8	13	2	8	9	19	3	2	2	7	6	5	2	13	52
Apprch %	7.7	30.8	61.5		10.5	42.1	47.4		42.9	28.6	28.6		46.2	38.5	15.4		
Total %	1.9	7.7	15.4	25	3.8	15.4	17.3	36.5	5.8	3.8	3.8	13.5	11.5	9.6	3.8	25	

Start Time	Sycamore Canyon Blvd Southbound				Eastridge Ave Westbound				Sycamore Canyon Blvd Northbound				Eastridge Ave Eastbound				Int. Total
	Left	Thru	Right	App. Total	Left	Thru	Right	App. Total	Left	Thru	Right	App. Total	Left	Thru	Right	App. Total	
Peak Hour Analysis From 04:30 PM to 05:15 PM - Peak 1 of 1																	
Peak Hour for Entire Intersection Begins at 04:30 PM																	
04:30 PM	0	0	0	0	0	1	0	1	0	0	1	1	1	2	1	4	6
04:45 PM	0	1	2	3	0	0	2	2	0	0	1	1	1	0	1	2	8
05:00 PM	0	0	0	0	0	0	0	0	1	0	0	1	0	0	0	0	1
05:15 PM	0	0	1	1	0	2	1	3	0	0	0	0	1	1	0	2	6
Total Volume	0	1	3	4	0	3	3	6	1	0	2	3	3	3	2	8	21
% App. Total	0	25	75		0	50	50		33.3	0	66.7		37.5	37.5	25		
PHF	.000	.250	.375	.333	.000	.375	.375	.500	.250	.000	.500	.750	.750	.375	.500	.500	.656

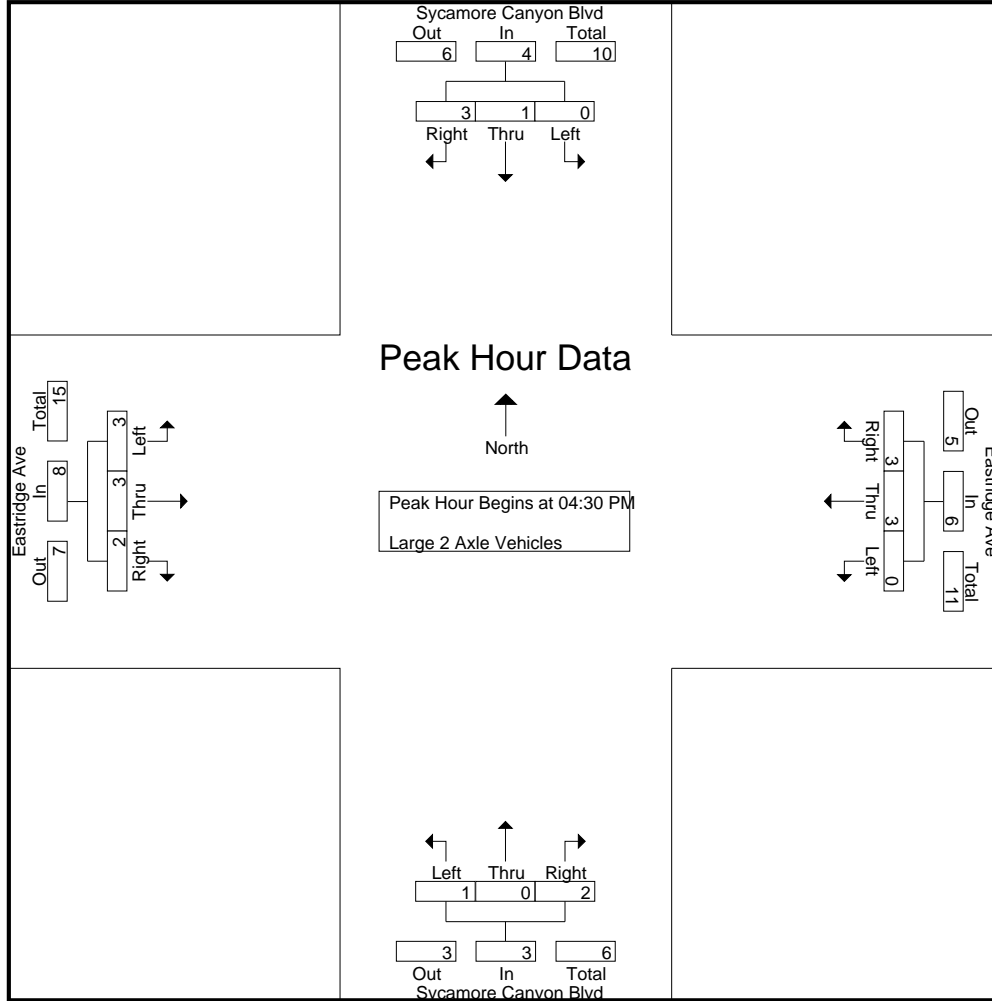

Peak Hour Analysis From 04:30 PM to 05:15 PM - Peak 1 of 1
 Peak Hour for Each Approach Begins at:

	04:30 PM				04:30 PM				04:30 PM				04:30 PM			
+0 mins.	0	0	0	0	0	1	0	1	0	0	1	1	1	2	1	4
+15 mins.	0	1	2	3	0	0	2	2	0	0	1	1	1	0	1	2
+30 mins.	0	0	0	0	0	0	0	0	1	0	0	1	0	0	0	0
+45 mins.	0	0	1	1	0	2	1	3	0	0	0	0	1	1	0	2
Total Volume	0	1	3	4	0	3	3	6	1	0	2	3	3	3	2	8
% App. Total	0	25	75		0	50	50		33.3	0	66.7		37.5	37.5	25	
PHF	.000	.250	.375	.333	.000	.375	.375	.500	.250	.000	.500	.750	.750	.375	.500	.500

Counts Unlimited Inc
 PO Box 1178
 Corona, CA 92878
 (951) 268-6268

City of Riverside
 N/S: Sycamore Canyon Blvd
 E/W: Eastridge Ave
 Weather: Clear

File Name : RIVSCERPM
 Site Code : 06715392
 Start Date : 7/7/2015
 Page No : 1

Groups Printed- 3 Axle Vehicles

Start Time	Sycamore Canyon Blvd Southbound				Eastridge Ave Westbound				Sycamore Canyon Blvd Northbound				Eastridge Ave Eastbound				Int. Total	
	Left	Thru	Right	App. Total	Left	Thru	Right	App. Total	Left	Thru	Right	App. Total	Left	Thru	Right	App. Total		
04:00 PM	0	0	0	0	0	0	1	1	0	0	0	0	0	0	0	0	0	1
04:15 PM	0	0	0	0	0	1	0	1	0	1	0	1	0	0	0	0	0	2
04:30 PM	0	0	0	0	0	0	1	1	0	1	0	1	0	0	0	0	0	2
04:45 PM	1	0	0	1	0	0	2	2	0	0	0	0	0	0	0	0	0	3
Total	1	0	0	1	0	1	4	5	0	2	0	2	0	0	0	0	0	8
05:00 PM	0	0	1	1	0	1	0	1	0	0	0	0	1	0	0	0	1	3
05:15 PM	0	2	0	2	0	0	1	1	0	1	0	1	0	1	1	1	2	6
05:30 PM	2	0	0	2	0	0	0	0	1	0	0	1	0	1	0	1	1	4
05:45 PM	0	0	0	0	0	0	2	2	0	0	0	0	0	0	0	0	0	2
Total	2	2	1	5	0	1	3	4	1	1	0	2	1	2	1	4	4	15
Grand Total	3	2	1	6	0	2	7	9	1	3	0	4	1	2	1	4	4	23
Apprch %	50	33.3	16.7		0	22.2	77.8		25	75	0		25	50	25			
Total %	13	8.7	4.3	26.1	0	8.7	30.4	39.1	4.3	13	0	17.4	4.3	8.7	4.3	17.4		

Start Time	Sycamore Canyon Blvd Southbound				Eastridge Ave Westbound				Sycamore Canyon Blvd Northbound				Eastridge Ave Eastbound				Int. Total	
	Left	Thru	Right	App. Total	Left	Thru	Right	App. Total	Left	Thru	Right	App. Total	Left	Thru	Right	App. Total		
Peak Hour Analysis From 04:30 PM to 05:15 PM - Peak 1 of 1																		
Peak Hour for Entire Intersection Begins at 04:30 PM																		
04:30 PM	0	0	0	0	0	0	1	1	0	1	0	1	0	0	0	0	0	2
04:45 PM	1	0	0	1	0	0	2	2	0	0	0	0	0	0	0	0	0	3
05:00 PM	0	0	1	1	0	1	0	1	0	0	0	0	1	0	0	1	1	3
05:15 PM	0	2	0	2	0	0	1	1	0	1	0	1	0	1	1	2	2	6
Total Volume	1	2	1	4	0	1	4	5	0	2	0	2	1	1	1	3	3	14
% App. Total	25	50	25		0	20	80		0	100	0		33.3	33.3	33.3			
PHF	.250	.250	.250	.500	.000	.250	.500	.625	.000	.500	.000	.500	.250	.250	.250	.375	.583	

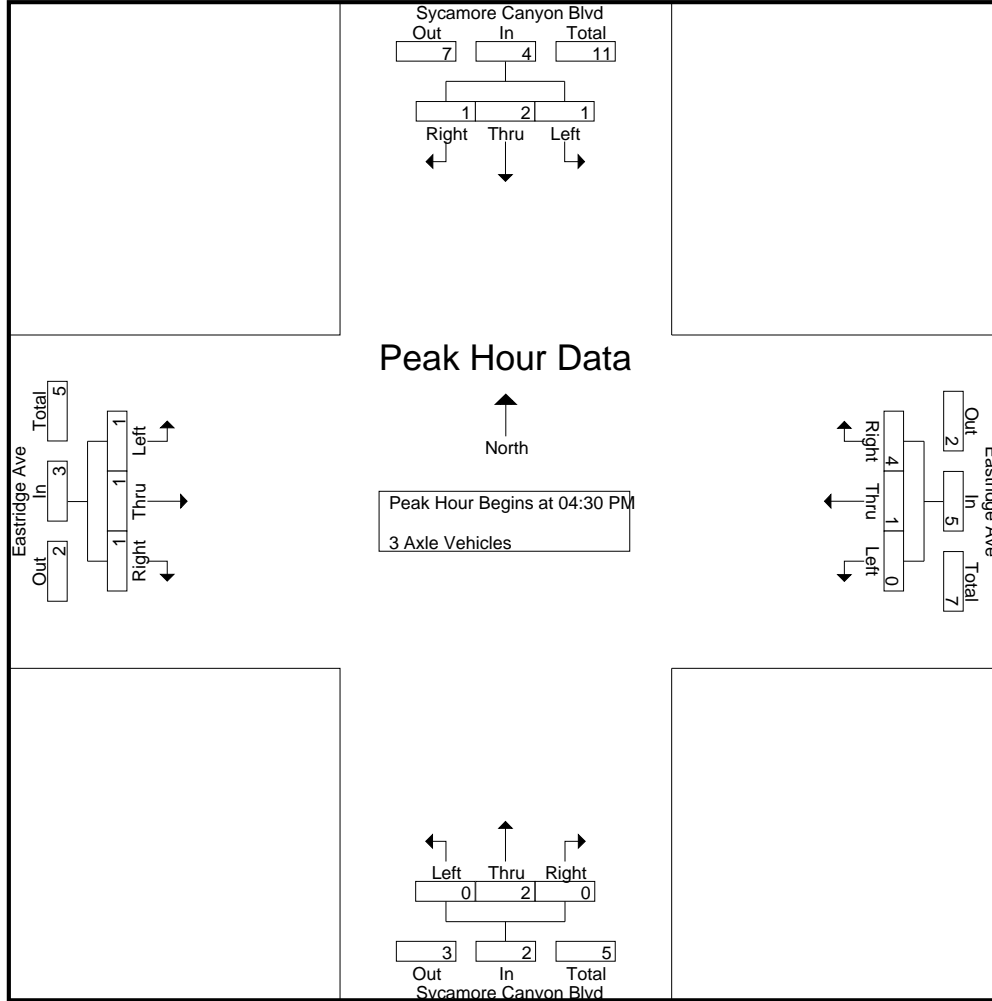

Peak Hour Analysis From 04:30 PM to 05:15 PM - Peak 1 of 1
 Peak Hour for Each Approach Begins at:

	04:30 PM				04:30 PM				04:30 PM				04:30 PM			
+0 mins.	0	0	0	0	0	0	1	1	0	1	0	1	0	0	0	0
+15 mins.	1	0	0	1	0	0	2	2	0	0	0	0	0	0	0	0
+30 mins.	0	0	1	1	0	1	0	1	0	0	0	0	1	0	0	1
+45 mins.	0	2	0	2	0	0	1	1	0	1	0	1	0	1	1	2
Total Volume	1	2	1	4	0	1	4	5	0	2	0	2	1	1	1	3
% App. Total	25	50	25		0	20	80		0	100	0		33.3	33.3	33.3	
PHF	.250	.250	.250	.500	.000	.250	.500	.625	.000	.500	.000	.500	.250	.250	.250	.375

Counts Unlimited Inc
 PO Box 1178
 Corona, CA 92878
 (951) 268-6268

City of Riverside
 N/S: Sycamore Canyon Blvd
 E/W: Eastridge Ave
 Weather: Clear

File Name : RIVSCERPM
 Site Code : 06715392
 Start Date : 7/7/2015
 Page No : 1

Groups Printed- 4+ Axle Trucks

Start Time	Sycamore Canyon Blvd Southbound				Eastridge Ave Westbound				Sycamore Canyon Blvd Northbound				Eastridge Ave Eastbound				Int. Total
	Left	Thru	Right	App. Total	Left	Thru	Right	App. Total	Left	Thru	Right	App. Total	Left	Thru	Right	App. Total	
04:00 PM	0	0	1	1	0	5	1	6	0	0	2	2	3	10	0	13	22
04:15 PM	0	0	0	0	1	4	0	5	0	2	2	4	1	7	0	8	17
04:30 PM	0	0	3	3	1	2	1	4	0	1	3	4	1	7	0	8	19
04:45 PM	2	1	0	3	1	6	2	9	2	0	2	4	1	5	0	6	22
Total	2	1	4	7	3	17	4	24	2	3	9	14	6	29	0	35	80
05:00 PM	1	1	0	2	0	2	0	2	0	1	4	5	1	4	1	6	15
05:15 PM	2	0	0	2	0	5	1	6	0	2	1	3	2	2	1	5	16
05:30 PM	1	1	0	2	2	3	0	5	0	1	0	1	1	7	0	8	16
05:45 PM	0	0	0	0	1	5	2	8	0	0	1	1	2	4	0	6	15
Total	4	2	0	6	3	15	3	21	0	4	6	10	6	17	2	25	62
Grand Total	6	3	4	13	6	32	7	45	2	7	15	24	12	46	2	60	142
Apprch %	46.2	23.1	30.8		13.3	71.1	15.6		8.3	29.2	62.5		20	76.7	3.3		
Total %	4.2	2.1	2.8	9.2	4.2	22.5	4.9	31.7	1.4	4.9	10.6	16.9	8.5	32.4	1.4	42.3	

Start Time	Sycamore Canyon Blvd Southbound				Eastridge Ave Westbound				Sycamore Canyon Blvd Northbound				Eastridge Ave Eastbound				Int. Total
	Left	Thru	Right	App. Total	Left	Thru	Right	App. Total	Left	Thru	Right	App. Total	Left	Thru	Right	App. Total	
Peak Hour Analysis From 04:30 PM to 05:15 PM - Peak 1 of 1																	
Peak Hour for Entire Intersection Begins at 04:30 PM																	
04:30 PM	0	0	3	3	1	2	1	4	0	1	3	4	1	7	0	8	19
04:45 PM	2	1	0	3	1	6	2	9	2	0	2	4	1	5	0	6	22
05:00 PM	1	1	0	2	0	2	0	2	0	1	4	5	1	4	1	6	15
05:15 PM	2	0	0	2	0	5	1	6	0	2	1	3	2	2	1	5	16
Total Volume	5	2	3	10	2	15	4	21	2	4	10	16	5	18	2	25	72
% App. Total	50	20	30		9.5	71.4	19		12.5	25	62.5		20	72	8		
PHF	.625	.500	.250	.833	.500	.625	.500	.583	.250	.500	.625	.800	.625	.643	.500	.781	.818

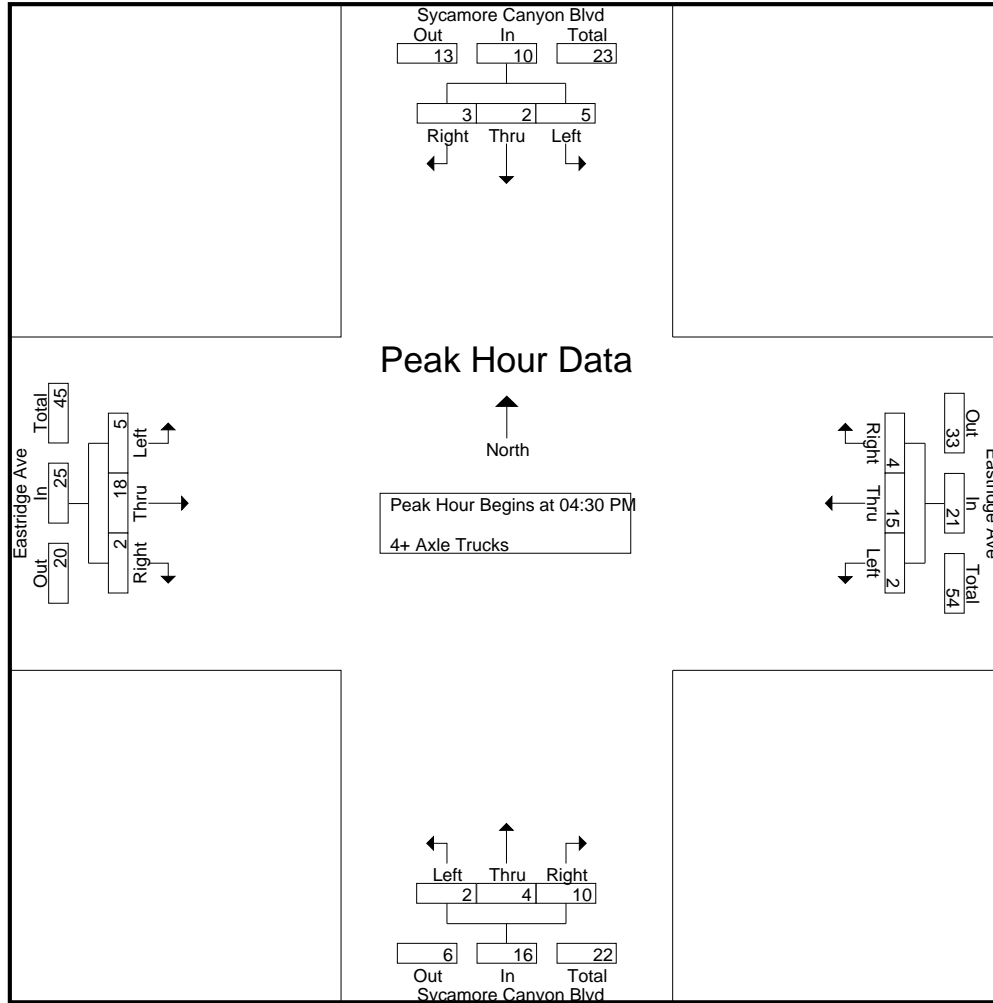

Peak Hour Analysis From 04:30 PM to 05:15 PM - Peak 1 of 1
 Peak Hour for Each Approach Begins at:

	04:30 PM				04:30 PM				04:30 PM				04:30 PM			
+0 mins.	0	0	3	3	1	2	1	4	0	1	3	4	1	7	0	8
+15 mins.	2	1	0	3	1	6	2	9	2	0	2	4	1	5	0	6
+30 mins.	1	1	0	2	0	2	0	2	0	1	4	5	1	4	1	6
+45 mins.	2	0	0	2	0	5	1	6	0	2	1	3	2	2	1	5
Total Volume	5	2	3	10	2	15	4	21	2	4	10	16	5	18	2	25
% App. Total	50	20	30		9.5	71.4	19		12.5	25	62.5		20	72	8	
PHF	.625	.500	.250	.833	.500	.625	.500	.583	.250	.500	.625	.800	.625	.643	.500	.781

Counts Unlimited Inc
PO Box 1178
Corona, CA 92878
(951) 268-6268

City of Riverside
N/S: Box Springs Blvd
E/W: Eastridge Ave
Weather: Clear

File Name : RIVBBERAM
Site Code : 06715392
Start Date : 7/7/2015
Page No : 1

Groups Printed- Passenger Vehicles - Large 2 Axle Vehicles - 3 Axle Vehicles - 4+ Axle Trucks

Start Time	Box Springs Blvd Southbound				Eastridge Ave Westbound				Box Springs Blvd Northbound				Eastridge Ave Eastbound				Int. Total
	Left	Thru	Right	App. Total	Left	Thru	Right	App. Total	Left	Thru	Right	App. Total	Left	Thru	Right	App. Total	
07:00 AM	4	0	2	6	15	156	62	233	2	1	1	4	11	30	4	45	288
07:15 AM	8	0	2	10	7	156	80	243	2	8	3	13	13	33	2	48	314
07:30 AM	5	1	0	6	15	182	89	286	5	1	3	9	9	48	2	59	360
07:45 AM	7	1	0	8	9	168	85	262	1	0	0	1	16	51	4	71	342
Total	24	2	4	30	46	662	316	1024	10	10	7	27	49	162	12	223	1304
08:00 AM	8	1	0	9	11	146	85	242	1	0	0	1	12	48	0	60	312
08:15 AM	10	1	0	11	3	123	46	172	0	1	0	1	4	43	0	47	231
08:30 AM	15	0	0	15	10	97	36	143	0	1	0	1	7	68	0	75	234
08:45 AM	13	1	1	15	10	103	39	152	4	1	1	6	9	36	2	47	220
Total	46	3	1	50	34	469	206	709	5	3	1	9	32	195	2	229	997
Grand Total	70	5	5	80	80	1131	522	1733	15	13	8	36	81	357	14	452	2301
Apprch %	87.5	6.2	6.2		4.6	65.3	30.1		41.7	36.1	22.2		17.9	79	3.1		
Total %	3	0.2	0.2	3.5	3.5	49.2	22.7	75.3	0.7	0.6	0.3	1.6	3.5	15.5	0.6	19.6	
Passenger Vehicles	54	4	1	59	71	1015	514	1600	13	10	7	30	69	280	13	362	2051
% Passenger Vehicles	77.1	80	20	73.8	88.8	89.7	98.5	92.3	86.7	76.9	87.5	83.3	85.2	78.4	92.9	80.1	89.1
Large 2 Axle Vehicles	7	0	1	8	5	27	3	35	1	3	1	5	7	16	1	24	72
% Large 2 Axle Vehicles	10	0	20	10	6.2	2.4	0.6	2	6.7	23.1	12.5	13.9	8.6	4.5	7.1	5.3	3.1
3 Axle Vehicles	1	0	0	1	0	7	1	8	1	0	0	1	2	3	0	5	15
% 3 Axle Vehicles	1.4	0	0	1.2	0	0.6	0.2	0.5	6.7	0	0	2.8	2.5	0.8	0	1.1	0.7
4+ Axle Trucks	8	1	3	12	4	82	4	90	0	0	0	0	3	58	0	61	163
% 4+ Axle Trucks	11.4	20	60	15	5	7.3	0.8	5.2	0	0	0	0	3.7	16.2	0	13.5	7.1

Start Time	Box Springs Blvd Southbound				Eastridge Ave Westbound				Box Springs Blvd Northbound				Eastridge Ave Eastbound				Int. Total
	Left	Thru	Right	App. Total	Left	Thru	Right	App. Total	Left	Thru	Right	App. Total	Left	Thru	Right	App. Total	
Peak Hour Analysis From 07:00 AM to 08:45 AM - Peak 1 of 1																	
Peak Hour for Entire Intersection Begins at 07:15 AM																	
07:15 AM	8	0	2	10	7	156	80	243	2	8	3	13	13	33	2	48	314
07:30 AM	5	1	0	6	15	182	89	286	5	1	3	9	9	48	2	59	360
07:45 AM	7	1	0	8	9	168	85	262	1	0	0	1	16	51	4	71	342
08:00 AM	8	1	0	9	11	146	85	242	1	0	0	1	12	48	0	60	312
Total Volume	28	3	2	33	42	652	339	1033	9	9	6	24	50	180	8	238	1328
% App. Total	84.8	9.1	6.1		4.1	63.1	32.8		37.5	37.5	25		21	75.6	3.4		
PHF	.875	.750	.250	.825	.700	.896	.952	.903	.450	.281	.500	.462	.781	.882	.500	.838	.922

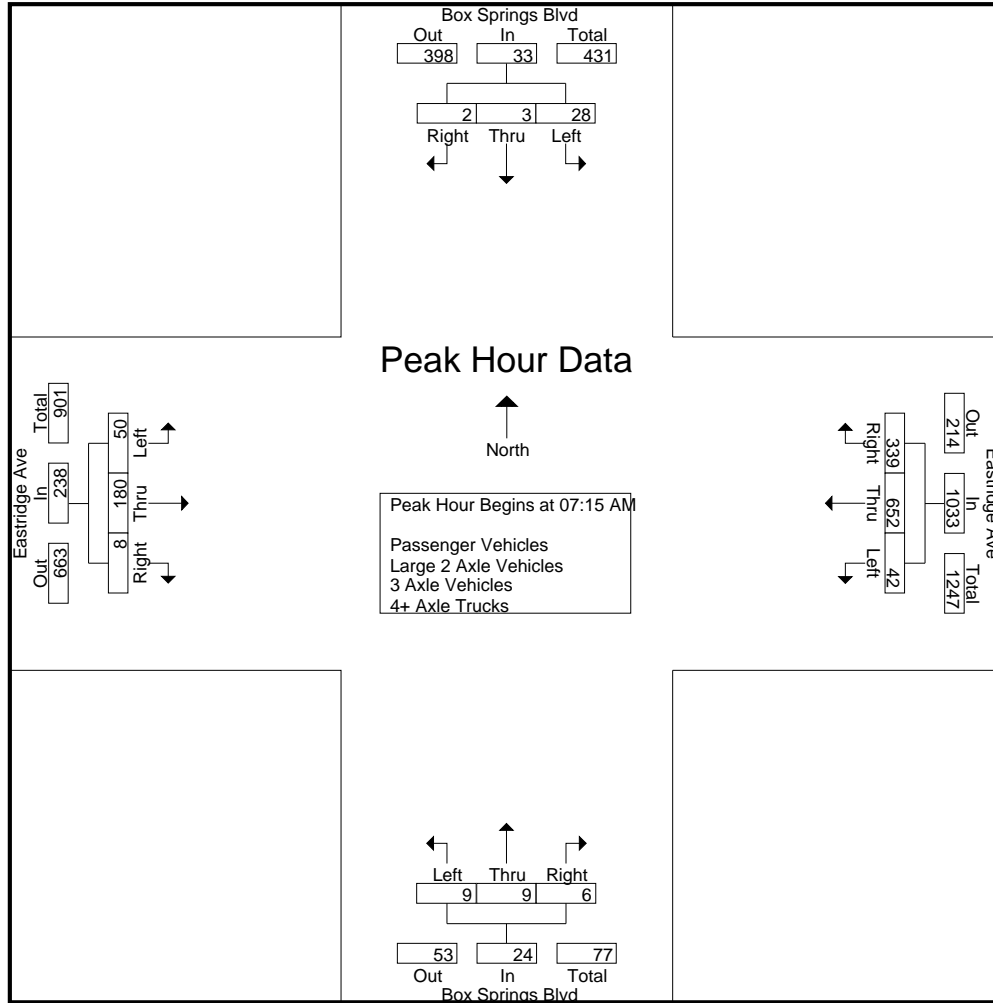

Peak Hour Analysis From 07:00 AM to 08:45 AM - Peak 1 of 1
 Peak Hour for Each Approach Begins at:

	08:00 AM				07:15 AM				07:00 AM				07:45 AM			
+0 mins.	8	1	0	9	7	156	80	243	2	1	1	4	16	51	4	71
+15 mins.	10	1	0	11	15	182	89	286	2	8	3	13	12	48	0	60
+30 mins.	15	0	0	15	9	168	85	262	5	1	3	9	4	43	0	47
+45 mins.	13	1	1	15	11	146	85	242	1	0	0	1	7	68	0	75
Total Volume	46	3	1	50	42	652	339	1033	10	10	7	27	39	210	4	253
% App. Total	92	6	2		4.1	63.1	32.8		37	37	25.9		15.4	83	1.6	
PHF	.767	.750	.250	.833	.700	.896	.952	.903	.500	.313	.583	.519	.609	.772	.250	.843

Counts Unlimited Inc
PO Box 1178
Corona, CA 92878
(951) 268-6268

City of Riverside
N/S: Box Springs Blvd
E/W: Eastridge Ave
Weather: Clear

File Name : RIVBBERAM
Site Code : 06715392
Start Date : 7/7/2015
Page No : 1

Groups Printed- Passenger Vehicles

Start Time	Box Springs Blvd Southbound				Eastridge Ave Westbound				Box Springs Blvd Northbound				Eastridge Ave Eastbound				Int. Total
	Left	Thru	Right	App. Total	Left	Thru	Right	App. Total	Left	Thru	Right	App. Total	Left	Thru	Right	App. Total	
07:00 AM	4	0	1	5	14	140	61	215	2	1	1	4	9	22	3	34	258
07:15 AM	5	0	0	5	7	136	80	223	2	7	3	12	10	29	2	41	281
07:30 AM	3	0	0	3	13	172	89	274	4	1	3	8	8	37	2	47	332
07:45 AM	6	1	0	7	8	159	81	248	1	0	0	1	15	38	4	57	313
Total	18	1	1	20	42	607	311	960	9	9	7	25	42	126	11	179	1184
08:00 AM	6	1	0	7	8	127	84	219	1	0	0	1	10	37	0	47	274
08:15 AM	7	1	0	8	2	107	45	154	0	1	0	1	3	31	0	34	197
08:30 AM	13	0	0	13	10	87	36	133	0	0	0	0	6	58	0	64	210
08:45 AM	10	1	0	11	9	87	38	134	3	0	0	3	8	28	2	38	186
Total	36	3	0	39	29	408	203	640	4	1	0	5	27	154	2	183	867
Grand Total	54	4	1	59	71	1015	514	1600	13	10	7	30	69	280	13	362	2051
Apprch %	91.5	6.8	1.7		4.4	63.4	32.1		43.3	33.3	23.3		19.1	77.3	3.6		
Total %	2.6	0.2	0	2.9	3.5	49.5	25.1	78	0.6	0.5	0.3	1.5	3.4	13.7	0.6	17.6	

Start Time	Box Springs Blvd Southbound				Eastridge Ave Westbound				Box Springs Blvd Northbound				Eastridge Ave Eastbound				Int. Total
	Left	Thru	Right	App. Total	Left	Thru	Right	App. Total	Left	Thru	Right	App. Total	Left	Thru	Right	App. Total	
Peak Hour Analysis From 07:15 AM to 08:00 AM - Peak 1 of 1																	
Peak Hour for Entire Intersection Begins at 07:15 AM																	
07:15 AM	5	0	0	5	7	136	80	223	2	7	3	12	10	29	2	41	281
07:30 AM	3	0	0	3	13	172	89	274	4	1	3	8	8	37	2	47	332
07:45 AM	6	1	0	7	8	159	81	248	1	0	0	1	15	38	4	57	313
08:00 AM	6	1	0	7	8	127	84	219	1	0	0	1	10	37	0	47	274
Total Volume	20	2	0	22	36	594	334	964	8	8	6	22	43	141	8	192	1200
% App. Total	90.9	9.1	0		3.7	61.6	34.6		36.4	36.4	27.3		22.4	73.4	4.2		
PHF	.833	.500	.000	.786	.692	.863	.938	.880	.500	.286	.500	.458	.717	.928	.500	.842	.904

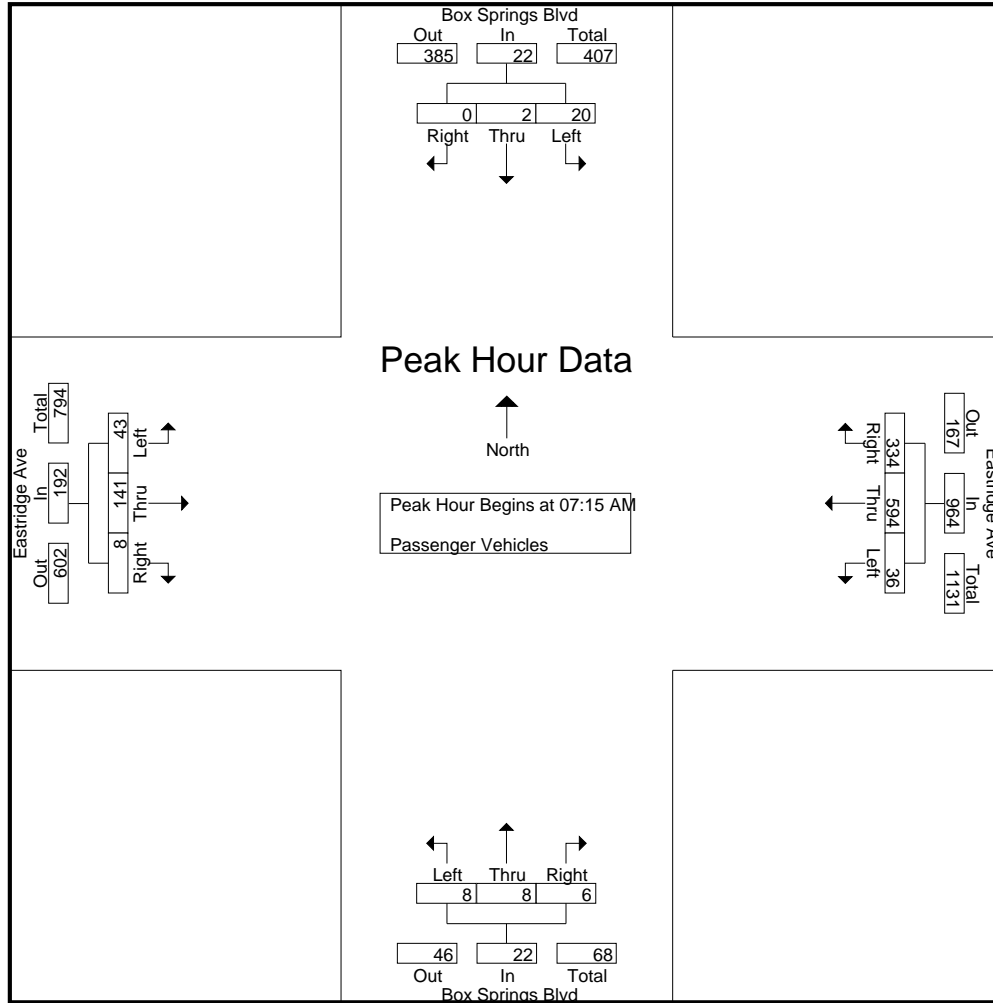

Peak Hour Analysis From 07:15 AM to 08:00 AM - Peak 1 of 1
 Peak Hour for Each Approach Begins at:

	07:15 AM				07:15 AM				07:15 AM				07:15 AM			
+0 mins.	5	0	0	5	7	136	80	223	2	7	3	12	10	29	2	41
+15 mins.	3	0	0	3	13	172	89	274	4	1	3	8	8	37	2	47
+30 mins.	6	1	0	7	8	159	81	248	1	0	0	1	15	38	4	57
+45 mins.	6	1	0	7	8	127	84	219	1	0	0	1	10	37	0	47
Total Volume	20	2	0	22	36	594	334	964	8	8	6	22	43	141	8	192
% App. Total	90.9	9.1	0		3.7	61.6	34.6		36.4	36.4	27.3		22.4	73.4	4.2	
PHF	.833	.500	.000	.786	.692	.863	.938	.880	.500	.286	.500	.458	.717	.928	.500	.842

Counts Unlimited Inc
PO Box 1178
Corona, CA 92878
(951) 268-6268

City of Riverside
N/S: Box Springs Blvd
E/W: Eastridge Ave
Weather: Clear

File Name : RIVBBERAM
Site Code : 06715392
Start Date : 7/7/2015
Page No : 1

Groups Printed- Large 2 Axle Vehicles

Start Time	Box Springs Blvd Southbound				Eastridge Ave Westbound				Box Springs Blvd Northbound				Eastridge Ave Eastbound				Int. Total
	Left	Thru	Right	App. Total	Left	Thru	Right	App. Total	Left	Thru	Right	App. Total	Left	Thru	Right	App. Total	
07:00 AM	0	0	1	1	0	1	0	1	0	0	0	0	2	1	1	4	6
07:15 AM	1	0	0	1	0	4	0	4	0	1	0	1	1	1	0	2	8
07:30 AM	2	0	0	2	2	1	0	3	0	0	0	0	1	3	0	4	9
07:45 AM	0	0	0	0	0	3	2	5	0	0	0	0	1	1	0	2	7
Total	3	0	1	4	2	9	2	13	0	1	0	1	5	6	1	12	30
08:00 AM	1	0	0	1	2	6	1	9	0	0	0	0	0	1	0	1	11
08:15 AM	1	0	0	1	0	4	0	4	0	0	0	0	0	3	0	3	8
08:30 AM	0	0	0	0	0	3	0	3	0	1	0	1	1	3	0	4	8
08:45 AM	2	0	0	2	1	5	0	6	1	1	1	3	1	3	0	4	15
Total	4	0	0	4	3	18	1	22	1	2	1	4	2	10	0	12	42
Grand Total	7	0	1	8	5	27	3	35	1	3	1	5	7	16	1	24	72
Apprch %	87.5	0	12.5		14.3	77.1	8.6		20	60	20		29.2	66.7	4.2		
Total %	9.7	0	1.4	11.1	6.9	37.5	4.2	48.6	1.4	4.2	1.4	6.9	9.7	22.2	1.4	33.3	

Start Time	Box Springs Blvd Southbound				Eastridge Ave Westbound				Box Springs Blvd Northbound				Eastridge Ave Eastbound				Int. Total
	Left	Thru	Right	App. Total	Left	Thru	Right	App. Total	Left	Thru	Right	App. Total	Left	Thru	Right	App. Total	
Peak Hour Analysis From 07:15 AM to 08:00 AM - Peak 1 of 1																	
Peak Hour for Entire Intersection Begins at 07:15 AM																	
07:15 AM	1	0	0	1	0	4	0	4	0	1	0	1	1	1	0	2	8
07:30 AM	2	0	0	2	2	1	0	3	0	0	0	0	1	3	0	4	9
07:45 AM	0	0	0	0	0	3	2	5	0	0	0	0	1	1	0	2	7
08:00 AM	1	0	0	1	2	6	1	9	0	0	0	0	0	1	0	1	11
Total Volume	4	0	0	4	4	14	3	21	0	1	0	1	3	6	0	9	35
% App. Total	100	0	0		19	66.7	14.3		0	100	0		33.3	66.7	0		
PHF	.500	.000	.000	.500	.500	.583	.375	.583	.000	.250	.000	.250	.750	.500	.000	.563	.795

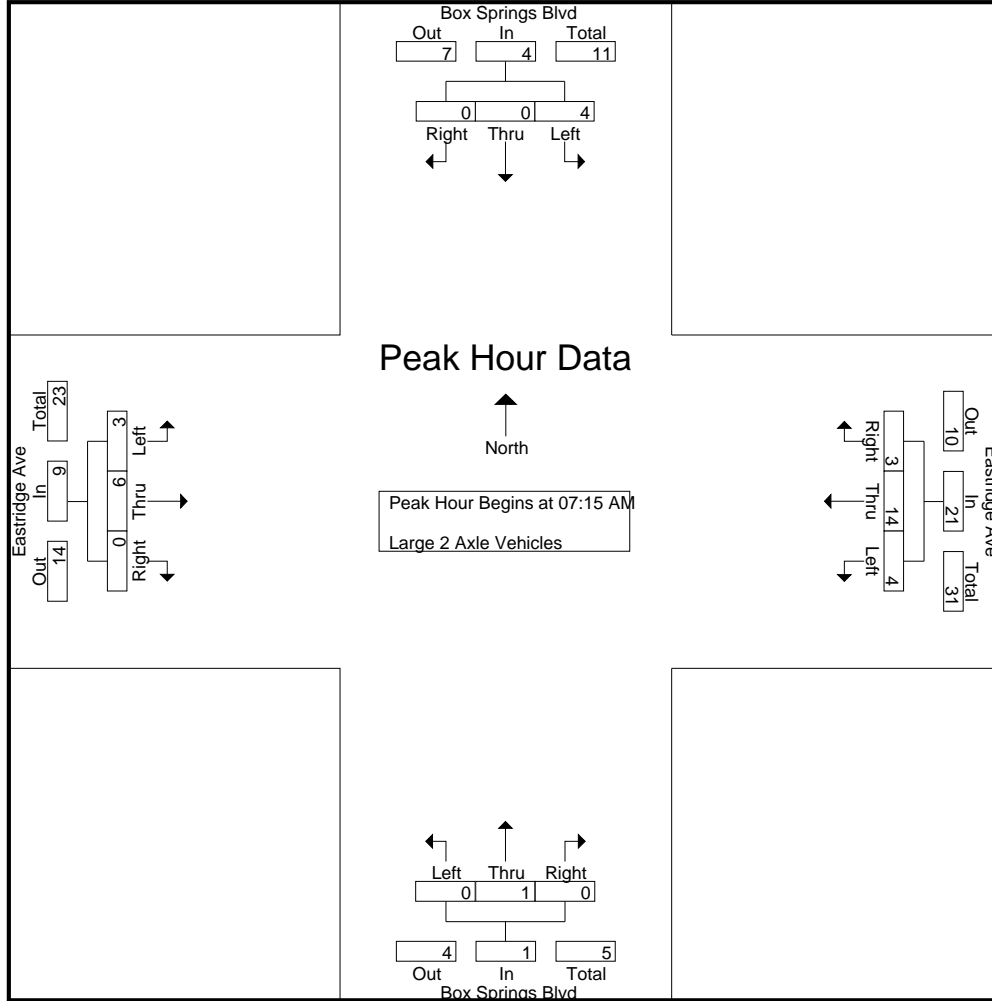

Peak Hour Analysis From 07:15 AM to 08:00 AM - Peak 1 of 1
 Peak Hour for Each Approach Begins at:

	07:15 AM				07:15 AM				07:15 AM				07:15 AM			
+0 mins.	1	0	0	1	0	4	0	4	0	1	0	1	1	1	0	2
+15 mins.	2	0	0	2	2	1	0	3	0	0	0	0	1	3	0	4
+30 mins.	0	0	0	0	0	3	2	5	0	0	0	0	1	1	0	2
+45 mins.	1	0	0	1	2	6	1	9	0	0	0	0	0	1	0	1
Total Volume	4	0	0	4	4	14	3	21	0	1	0	1	3	6	0	9
% App. Total	100	0	0		19	66.7	14.3		0	100	0		33.3	66.7	0	
PHF	.500	.000	.000	.500	.500	.583	.375	.583	.000	.250	.000	.250	.750	.500	.000	.563

Counts Unlimited Inc
PO Box 1178
Corona, CA 92878
(951) 268-6268

City of Riverside
N/S: Box Springs Blvd
E/W: Eastridge Ave
Weather: Clear

File Name : RIVBBERAM
Site Code : 06715392
Start Date : 7/7/2015
Page No : 1

Groups Printed- 3 Axle Vehicles

Start Time	Box Springs Blvd Southbound				Eastridge Ave Westbound				Box Springs Blvd Northbound				Eastridge Ave Eastbound				Int. Total
	Left	Thru	Right	App. Total	Left	Thru	Right	App. Total	Left	Thru	Right	App. Total	Left	Thru	Right	App. Total	
07:00 AM	0	0	0	0	0	1	0	1	0	0	0	0	0	0	0	0	1
07:15 AM	0	0	0	0	0	1	0	1	0	0	0	0	0	0	0	0	1
07:30 AM	0	0	0	0	0	1	0	1	1	0	0	1	0	0	0	0	2
07:45 AM	0	0	0	0	0	0	1	1	0	0	0	0	0	0	0	0	1
Total	0	0	0	0	0	3	1	4	1	0	0	1	0	0	0	0	5
08:00 AM	0	0	0	0	0	1	0	1	0	0	0	0	2	2	0	4	5
08:15 AM	1	0	0	1	0	3	0	3	0	0	0	0	0	0	0	0	4
08:30 AM	0	0	0	0	0	0	0	0	0	0	0	0	0	1	0	1	1
08:45 AM	0	0	0	0	0	0	0	0	0	0	0	0	0	0	0	0	0
Total	1	0	0	1	0	4	0	4	0	0	0	0	2	3	0	5	10
Grand Total	1	0	0	1	0	7	1	8	1	0	0	1	2	3	0	5	15
Apprch %	100	0	0		0	87.5	12.5		100	0	0		40	60	0		
Total %	6.7	0	0	6.7	0	46.7	6.7	53.3	6.7	0	0	6.7	13.3	20	0	33.3	

Start Time	Box Springs Blvd Southbound				Eastridge Ave Westbound				Box Springs Blvd Northbound				Eastridge Ave Eastbound				Int. Total
	Left	Thru	Right	App. Total	Left	Thru	Right	App. Total	Left	Thru	Right	App. Total	Left	Thru	Right	App. Total	
Peak Hour Analysis From 07:15 AM to 08:00 AM - Peak 1 of 1																	
Peak Hour for Entire Intersection Begins at 07:15 AM																	
07:15 AM	0	0	0	0	0	1	0	1	0	0	0	0	0	0	0	0	1
07:30 AM	0	0	0	0	0	1	0	1	1	0	0	1	0	0	0	0	2
07:45 AM	0	0	0	0	0	0	1	1	0	0	0	0	0	0	0	0	1
08:00 AM	0	0	0	0	0	1	0	1	0	0	0	0	2	2	0	4	5
Total Volume	0	0	0	0	0	3	1	4	1	0	0	1	2	2	0	4	9
% App. Total	0	0	0		0	75	25		100	0	0		50	50	0		
PHF	.000	.000	.000	.000	.000	.750	.250	1.00	.250	.000	.000	.250	.250	.250	.000	.250	.450

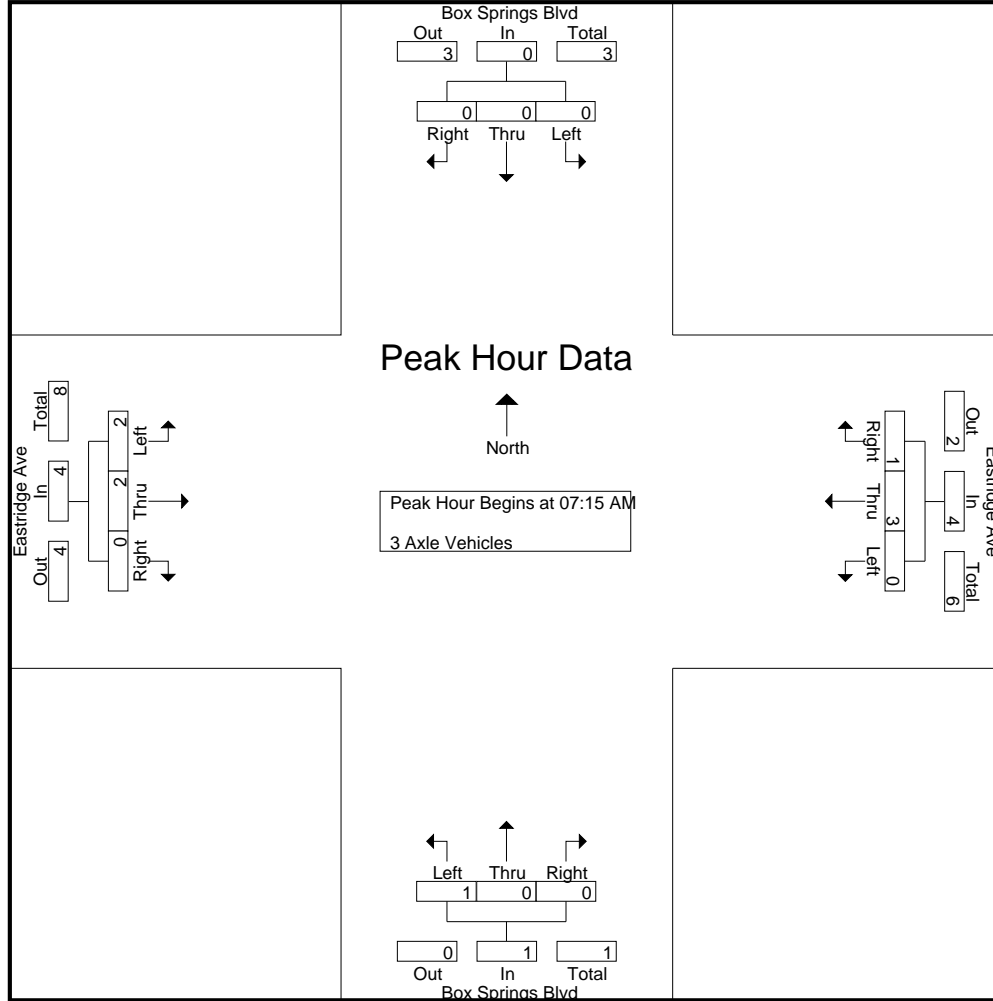

Peak Hour Analysis From 07:15 AM to 08:00 AM - Peak 1 of 1
 Peak Hour for Each Approach Begins at:

	07:15 AM				07:15 AM				07:15 AM				07:15 AM			
+0 mins.	0	0	0	0	0	1	0	1	0	0	0	0	0	0	0	0
+15 mins.	0	0	0	0	0	1	0	1	1	0	0	0	1	0	0	0
+30 mins.	0	0	0	0	0	0	1	1	0	0	0	0	0	0	0	0
+45 mins.	0	0	0	0	0	1	0	1	0	0	0	0	0	2	2	0
Total Volume	0	0	0	0	0	3	1	4	1	0	0	1	2	2	0	4
% App. Total	0	0	0	0	0	75	25	100	100	0	0	0	50	50	0	0
PHF	.000	.000	.000	.000	.000	.750	.250	1.000	.250	.000	.000	.250	.250	.250	.000	.250

Counts Unlimited Inc
PO Box 1178
Corona, CA 92878
(951) 268-6268

City of Riverside
N/S: Box Springs Blvd
E/W: Eastridge Ave
Weather: Clear

File Name : RIVBBERAM
Site Code : 06715392
Start Date : 7/7/2015
Page No : 1

Groups Printed- 4+ Axle Trucks

Start Time	Box Springs Blvd Southbound				Eastridge Ave Westbound				Box Springs Blvd Northbound				Eastridge Ave Eastbound				Int. Total
	Left	Thru	Right	App. Total	Left	Thru	Right	App. Total	Left	Thru	Right	App. Total	Left	Thru	Right	App. Total	
07:00 AM	0	0	0	0	1	14	1	16	0	0	0	0	0	7	0	7	23
07:15 AM	2	0	2	4	0	15	0	15	0	0	0	0	2	3	0	5	24
07:30 AM	0	1	0	1	0	8	0	8	0	0	0	0	0	8	0	8	17
07:45 AM	1	0	0	1	1	6	1	8	0	0	0	0	0	12	0	12	21
Total	3	1	2	6	2	43	2	47	0	0	0	0	2	30	0	32	85
08:00 AM	1	0	0	1	1	12	0	13	0	0	0	0	0	8	0	8	22
08:15 AM	1	0	0	1	1	9	1	11	0	0	0	0	1	9	0	10	22
08:30 AM	2	0	0	2	0	7	0	7	0	0	0	0	0	6	0	6	15
08:45 AM	1	0	1	2	0	11	1	12	0	0	0	0	0	5	0	5	19
Total	5	0	1	6	2	39	2	43	0	0	0	0	1	28	0	29	78
Grand Total	8	1	3	12	4	82	4	90	0	0	0	0	3	58	0	61	163
Apprch %	66.7	8.3	25		4.4	91.1	4.4		0	0	0		4.9	95.1	0		
Total %	4.9	0.6	1.8	7.4	2.5	50.3	2.5	55.2	0	0	0	0	1.8	35.6	0	37.4	

Start Time	Box Springs Blvd Southbound				Eastridge Ave Westbound				Box Springs Blvd Northbound				Eastridge Ave Eastbound				Int. Total
	Left	Thru	Right	App. Total	Left	Thru	Right	App. Total	Left	Thru	Right	App. Total	Left	Thru	Right	App. Total	
Peak Hour Analysis From 07:15 AM to 08:00 AM - Peak 1 of 1																	
Peak Hour for Entire Intersection Begins at 07:15 AM																	
07:15 AM	2	0	2	4	0	15	0	15	0	0	0	0	2	3	0	5	24
07:30 AM	0	1	0	1	0	8	0	8	0	0	0	0	0	8	0	8	17
07:45 AM	1	0	0	1	1	6	1	8	0	0	0	0	0	12	0	12	21
08:00 AM	1	0	0	1	1	12	0	13	0	0	0	0	0	8	0	8	22
Total Volume	4	1	2	7	2	41	1	44	0	0	0	0	2	31	0	33	84
% App. Total	57.1	14.3	28.6		4.5	93.2	2.3		0	0	0		6.1	93.9	0		
PHF	.500	.250	.250	.438	.500	.683	.250	.733	.000	.000	.000	.000	.250	.646	.000	.688	.875

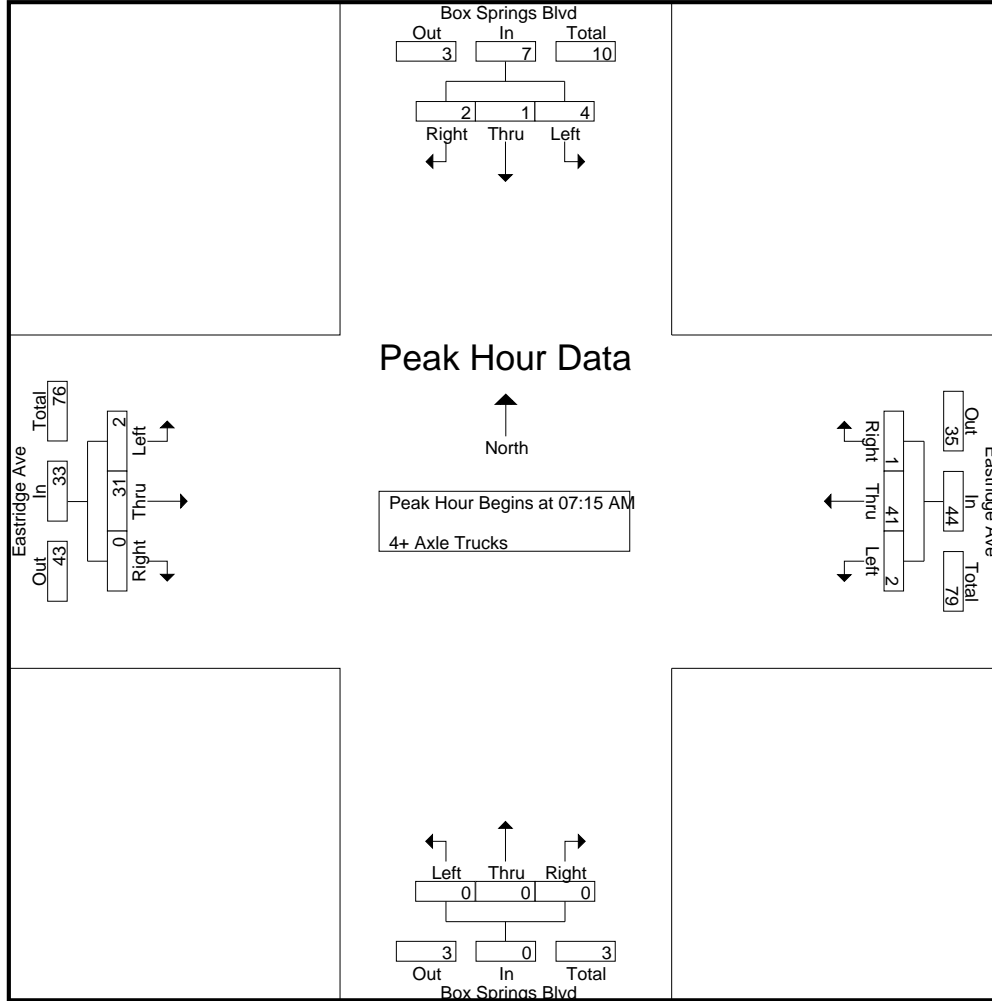

Peak Hour Analysis From 07:15 AM to 08:00 AM - Peak 1 of 1
 Peak Hour for Each Approach Begins at:

	07:15 AM				07:15 AM				07:15 AM				07:15 AM			
+0 mins.	2	0	2	4	0	15	0	15	0	0	0	0	2	3	0	5
+15 mins.	0	1	0	1	0	8	0	8	0	0	0	0	0	8	0	8
+30 mins.	1	0	0	1	1	6	1	8	0	0	0	0	0	12	0	12
+45 mins.	1	0	0	1	1	12	0	13	0	0	0	0	0	8	0	8
Total Volume	4	1	2	7	2	41	1	44	0	0	0	0	2	31	0	33
% App. Total	57.1	14.3	28.6		4.5	93.2	2.3		0	0	0		6.1	93.9	0	
PHF	.500	.250	.250	.438	.500	.683	.250	.733	.000	.000	.000	.000	.250	.646	.000	.688

Counts Unlimited Inc
PO Box 1178
Corona, CA 92878
(951) 268-6268

City of Riverside
N/S: Box Springs Blvd
E/W: Eastridge Ave
Weather: Clear

File Name : RIVBBERPM
Site Code : 06715392
Start Date : 7/7/2015
Page No : 1

Groups Printed- Passenger Vehicles - Large 2 Axle Vehicles - 3 Axle Vehicles - 4+ Axle Trucks

Start Time	Box Springs Blvd Southbound				Eastridge Ave Westbound				Box Springs Blvd Northbound				Eastridge Ave Eastbound				Int. Total
	Left	Thru	Right	App. Total	Left	Thru	Right	App. Total	Left	Thru	Right	App. Total	Left	Thru	Right	App. Total	
04:00 PM	32	0	1	33	2	94	22	118	4	0	1	5	3	142	1	146	302
04:15 PM	24	2	2	28	2	74	16	92	3	1	0	4	6	106	1	113	237
04:30 PM	43	0	4	47	3	92	11	106	6	1	1	8	5	141	2	148	309
04:45 PM	27	1	1	29	3	97	15	115	1	1	0	2	4	107	0	111	257
Total	126	3	8	137	10	357	64	431	14	3	2	19	18	496	4	518	1105
05:00 PM	59	1	7	67	4	70	7	81	2	1	0	3	3	164	1	168	319
05:15 PM	28	1	2	31	4	95	10	109	0	2	0	2	2	102	0	104	246
05:30 PM	26	0	0	26	6	73	10	89	6	1	0	7	2	83	0	85	207
05:45 PM	19	0	1	20	4	83	5	92	0	2	1	3	3	66	0	69	184
Total	132	2	10	144	18	321	32	371	8	6	1	15	10	415	1	426	956
Grand Total	258	5	18	281	28	678	96	802	22	9	3	34	28	911	5	944	2061
Apprch %	91.8	1.8	6.4		3.5	84.5	12		64.7	26.5	8.8		3	96.5	0.5		
Total %	12.5	0.2	0.9	13.6	1.4	32.9	4.7	38.9	1.1	0.4	0.1	1.6	1.4	44.2	0.2	45.8	
Passenger Vehicles	253	2	18	273	17	614	89	720	19	4	3	26	23	840	3	866	1885
% Passenger Vehicles	98.1	40	100	97.2	60.7	90.6	92.7	89.8	86.4	44.4	100	76.5	82.1	92.2	60	91.7	91.5
Large 2 Axle Vehicles	3	1	0	4	3	17	1	21	2	0	0	2	2	7	0	9	36
% Large 2 Axle Vehicles	1.2	20	0	1.4	10.7	2.5	1	2.6	9.1	0	0	5.9	7.1	0.8	0	1	1.7
3 Axle Vehicles	0	1	0	1	1	4	0	5	0	2	0	2	0	4	0	4	12
% 3 Axle Vehicles	0	20	0	0.4	3.6	0.6	0	0.6	0	22.2	0	5.9	0	0.4	0	0.4	0.6
4+ Axle Trucks	2	1	0	3	7	43	6	56	1	3	0	4	3	60	2	65	128
% 4+ Axle Trucks	0.8	20	0	1.1	25	6.3	6.2	7	4.5	33.3	0	11.8	10.7	6.6	40	6.9	6.2

Start Time	Box Springs Blvd Southbound				Eastridge Ave Westbound				Box Springs Blvd Northbound				Eastridge Ave Eastbound				Int. Total
	Left	Thru	Right	App. Total	Left	Thru	Right	App. Total	Left	Thru	Right	App. Total	Left	Thru	Right	App. Total	
Peak Hour Analysis From 04:00 PM to 05:45 PM - Peak 1 of 1																	
Peak Hour for Entire Intersection Begins at 04:30 PM																	
04:30 PM	43	0	4	47	3	92	11	106	6	1	1	8	5	141	2	148	309
04:45 PM	27	1	1	29	3	97	15	115	1	1	0	2	4	107	0	111	257
05:00 PM	59	1	7	67	4	70	7	81	2	1	0	3	3	164	1	168	319
05:15 PM	28	1	2	31	4	95	10	109	0	2	0	2	2	102	0	104	246
Total Volume	157	3	14	174	14	354	43	411	9	5	1	15	14	514	3	531	1131
% App. Total	90.2	1.7	8		3.4	86.1	10.5		60	33.3	6.7		2.6	96.8	0.6		
PHF	.665	.750	.500	.649	.875	.912	.717	.893	.375	.625	.250	.469	.700	.784	.375	.790	.886

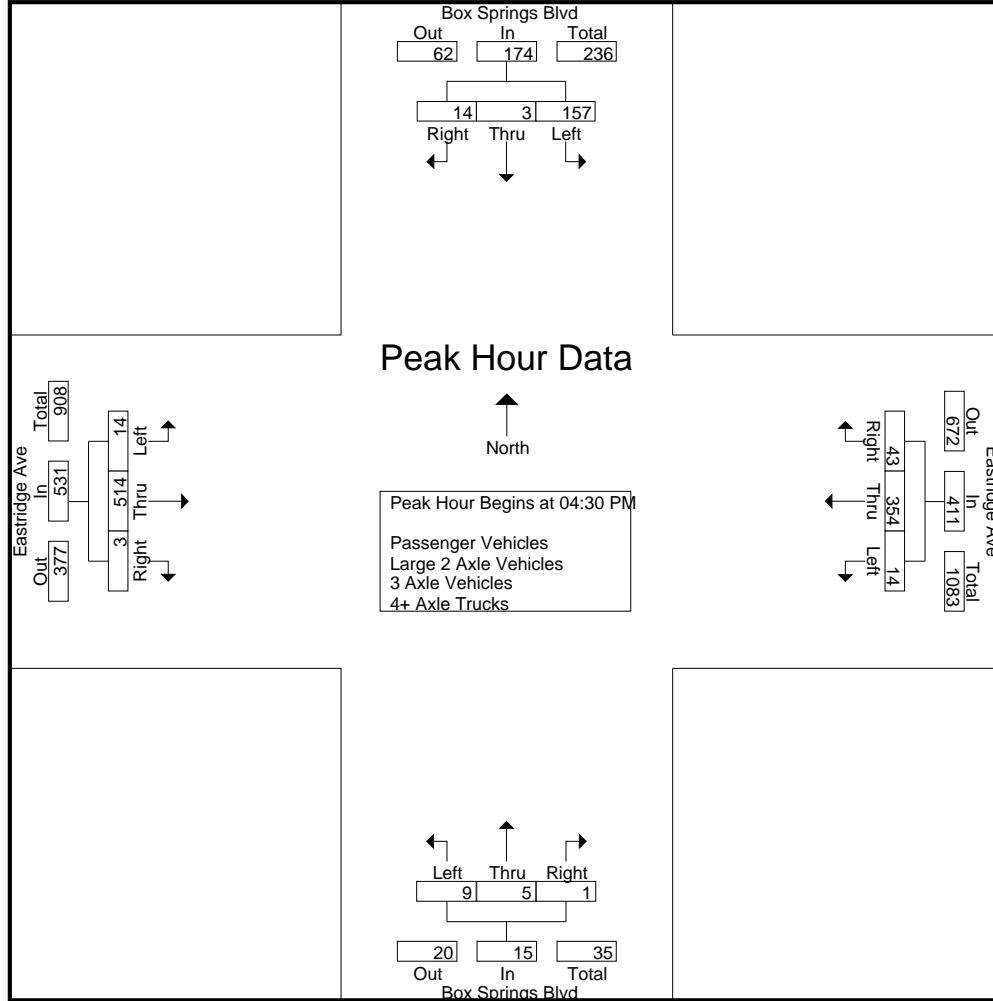

Peak Hour Analysis From 04:00 PM to 05:45 PM - Peak 1 of 1
 Peak Hour for Each Approach Begins at:

	04:30 PM				04:00 PM				04:00 PM				04:15 PM			
+0 mins.	43	0	4	47	2	94	22	118	4	0	1	5	6	106	1	113
+15 mins.	27	1	1	29	2	74	16	92	3	1	0	4	5	141	2	148
+30 mins.	59	1	7	67	3	92	11	106	6	1	1	8	4	107	0	111
+45 mins.	28	1	2	31	3	97	15	115	1	1	0	2	3	164	1	168
Total Volume	157	3	14	174	10	357	64	431	14	3	2	19	18	518	4	540
% App. Total	90.2	1.7	8		2.3	82.8	14.8		73.7	15.8	10.5		3.3	95.9	0.7	
PHF	.665	.750	.500	.649	.833	.920	.727	.913	.583	.750	.500	.594	.750	.790	.500	.804

Counts Unlimited Inc
PO Box 1178
Corona, CA 92878
(951) 268-6268

City of Riverside
N/S: Box Springs Blvd
E/W: Eastridge Ave
Weather: Clear

File Name : RIVBBERPM
Site Code : 06715392
Start Date : 7/7/2015
Page No : 1

Groups Printed- Passenger Vehicles

Start Time	Box Springs Blvd Southbound				Eastridge Ave Westbound				Box Springs Blvd Northbound				Eastridge Ave Eastbound				Int. Total
	Left	Thru	Right	App. Total	Left	Thru	Right	App. Total	Left	Thru	Right	App. Total	Left	Thru	Right	App. Total	
04:00 PM	31	0	1	32	1	84	22	107	4	0	1	5	3	131	0	134	278
04:15 PM	23	1	2	26	0	67	15	82	2	0	0	2	5	98	0	103	213
04:30 PM	41	0	4	45	1	88	10	99	5	1	1	7	4	130	2	136	287
04:45 PM	26	0	1	27	2	86	13	101	1	0	0	1	2	98	0	100	229
Total	121	1	8	130	4	325	60	389	12	1	2	15	14	457	2	473	1007
05:00 PM	59	0	7	66	3	65	6	74	2	0	0	2	2	155	1	158	300
05:15 PM	28	1	2	31	3	85	9	97	0	2	0	2	2	94	0	96	226
05:30 PM	26	0	0	26	3	66	9	78	5	1	0	6	2	73	0	75	185
05:45 PM	19	0	1	20	4	73	5	82	0	0	1	1	3	61	0	64	167
Total	132	1	10	143	13	289	29	331	7	3	1	11	9	383	1	393	878
Grand Total	253	2	18	273	17	614	89	720	19	4	3	26	23	840	3	866	1885
Apprch %	92.7	0.7	6.6		2.4	85.3	12.4		73.1	15.4	11.5		2.7	97	0.3		
Total %	13.4	0.1	1	14.5	0.9	32.6	4.7	38.2	1	0.2	0.2	1.4	1.2	44.6	0.2	45.9	

Start Time	Box Springs Blvd Southbound				Eastridge Ave Westbound				Box Springs Blvd Northbound				Eastridge Ave Eastbound				Int. Total
	Left	Thru	Right	App. Total	Left	Thru	Right	App. Total	Left	Thru	Right	App. Total	Left	Thru	Right	App. Total	
Peak Hour Analysis From 04:30 PM to 05:15 PM - Peak 1 of 1																	
Peak Hour for Entire Intersection Begins at 04:30 PM																	
04:30 PM	41	0	4	45	1	88	10	99	5	1	1	7	4	130	2	136	287
04:45 PM	26	0	1	27	2	86	13	101	1	0	0	1	2	98	0	100	229
05:00 PM	59	0	7	66	3	65	6	74	2	0	0	2	2	155	1	158	300
05:15 PM	28	1	2	31	3	85	9	97	0	2	0	2	2	94	0	96	226
Total Volume	154	1	14	169	9	324	38	371	8	3	1	12	10	477	3	490	1042
% App. Total	91.1	0.6	8.3		2.4	87.3	10.2		66.7	25	8.3		2	97.3	0.6		
PHF	.653	.250	.500	.640	.750	.920	.731	.918	.400	.375	.250	.429	.625	.769	.375	.775	.868

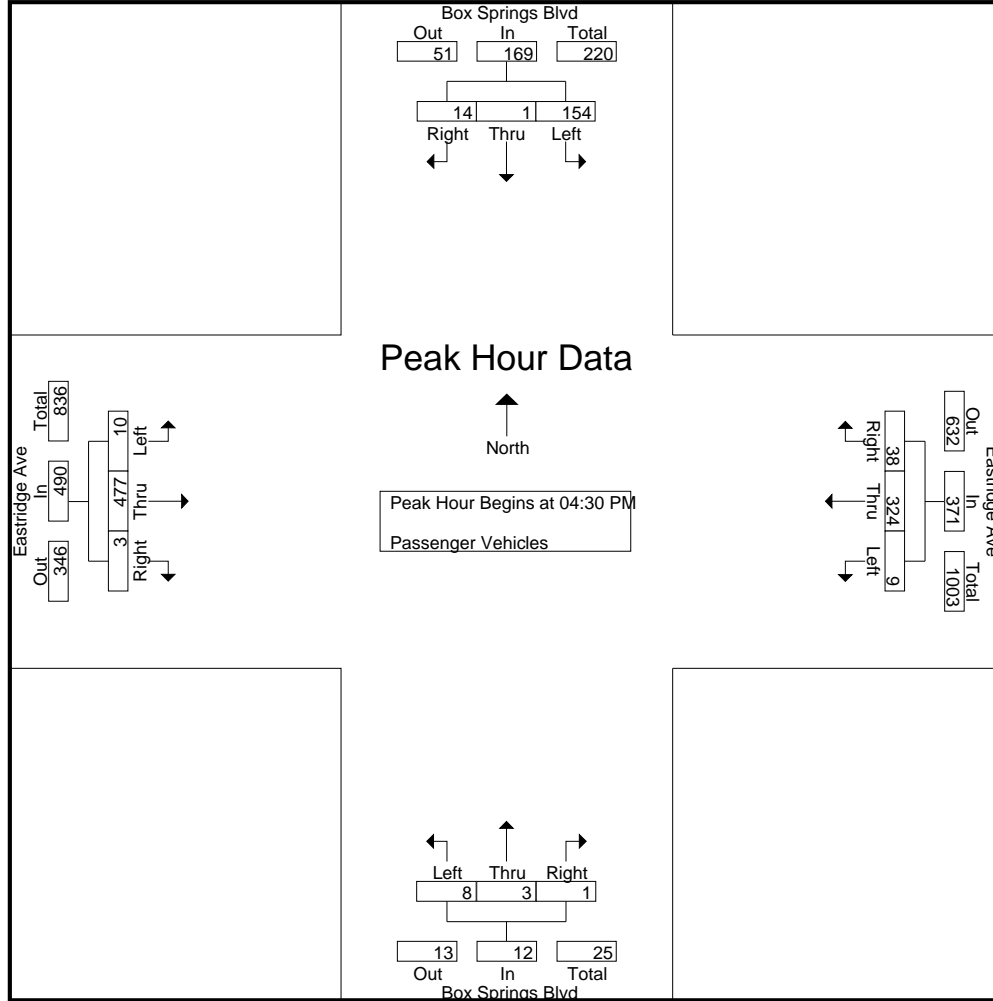

Peak Hour Analysis From 04:30 PM to 05:15 PM - Peak 1 of 1
 Peak Hour for Each Approach Begins at:

	04:30 PM				04:30 PM				04:30 PM				04:30 PM			
+0 mins.	41	0	4	45	1	88	10	99	5	1	1	7	4	130	2	136
+15 mins.	26	0	1	27	2	86	13	101	1	0	0	1	2	98	0	100
+30 mins.	59	0	7	66	3	65	6	74	2	0	0	2	2	155	1	158
+45 mins.	28	1	2	31	3	85	9	97	0	2	0	2	2	94	0	96
Total Volume	154	1	14	169	9	324	38	371	8	3	1	12	10	477	3	490
% App. Total	91.1	0.6	8.3		2.4	87.3	10.2		66.7	25	8.3		2	97.3	0.6	
PHF	.653	.250	.500	.640	.750	.920	.731	.918	.400	.375	.250	.429	.625	.769	.375	.775

Counts Unlimited Inc
 PO Box 1178
 Corona, CA 92878
 (951) 268-6268

City of Riverside
 N/S: Box Springs Blvd
 E/W: Eastridge Ave
 Weather: Clear

File Name : RIVBBBERPM
 Site Code : 06715392
 Start Date : 7/7/2015
 Page No : 1

Groups Printed- Large 2 Axle Vehicles

Start Time	Box Springs Blvd Southbound				Eastridge Ave Westbound				Box Springs Blvd Northbound				Eastridge Ave Eastbound				Int. Total
	Left	Thru	Right	App. Total	Left	Thru	Right	App. Total	Left	Thru	Right	App. Total	Left	Thru	Right	App. Total	
04:00 PM	1	0	0	1	0	4	0	4	0	0	0	0	0	1	0	1	6
04:15 PM	0	1	0	1	2	1	0	3	1	0	0	1	0	0	0	0	5
04:30 PM	1	0	0	1	0	1	0	1	0	0	0	0	1	2	0	3	5
04:45 PM	1	0	0	1	0	2	0	2	0	0	0	0	1	0	0	1	4
Total	3	1	0	4	2	8	0	10	1	0	0	1	2	3	0	5	20
05:00 PM	0	0	0	0	0	1	0	1	0	0	0	0	0	0	0	0	1
05:15 PM	0	0	0	0	0	4	1	5	0	0	0	0	0	2	0	2	7
05:30 PM	0	0	0	0	1	2	0	3	1	0	0	1	0	1	0	1	5
05:45 PM	0	0	0	0	0	2	0	2	0	0	0	0	0	1	0	1	3
Total	0	0	0	0	1	9	1	11	1	0	0	1	0	4	0	4	16
Grand Total	3	1	0	4	3	17	1	21	2	0	0	2	2	7	0	9	36
Apprch %	75	25	0		14.3	81	4.8		100	0	0		22.2	77.8	0		
Total %	8.3	2.8	0	11.1	8.3	47.2	2.8	58.3	5.6	0	0	5.6	5.6	19.4	0	25	

Start Time	Box Springs Blvd Southbound				Eastridge Ave Westbound				Box Springs Blvd Northbound				Eastridge Ave Eastbound				Int. Total
	Left	Thru	Right	App. Total	Left	Thru	Right	App. Total	Left	Thru	Right	App. Total	Left	Thru	Right	App. Total	
Peak Hour Analysis From 04:30 PM to 05:15 PM - Peak 1 of 1																	
Peak Hour for Entire Intersection Begins at 04:30 PM																	
04:30 PM	1	0	0	1	0	1	0	1	0	0	0	0	1	2	0	3	5
04:45 PM	1	0	0	1	0	2	0	2	0	0	0	0	1	0	0	1	4
05:00 PM	0	0	0	0	0	1	0	1	0	0	0	0	0	0	0	0	1
05:15 PM	0	0	0	0	0	4	1	5	0	0	0	0	0	2	0	2	7
Total Volume	2	0	0	2	0	8	1	9	0	0	0	0	2	4	0	6	17
% App. Total	100	0	0		0	88.9	11.1		0	0	0		33.3	66.7	0		
PHF	.500	.000	.000	.500	.000	.500	.250	.450	.000	.000	.000	.000	.500	.500	.000	.500	.607

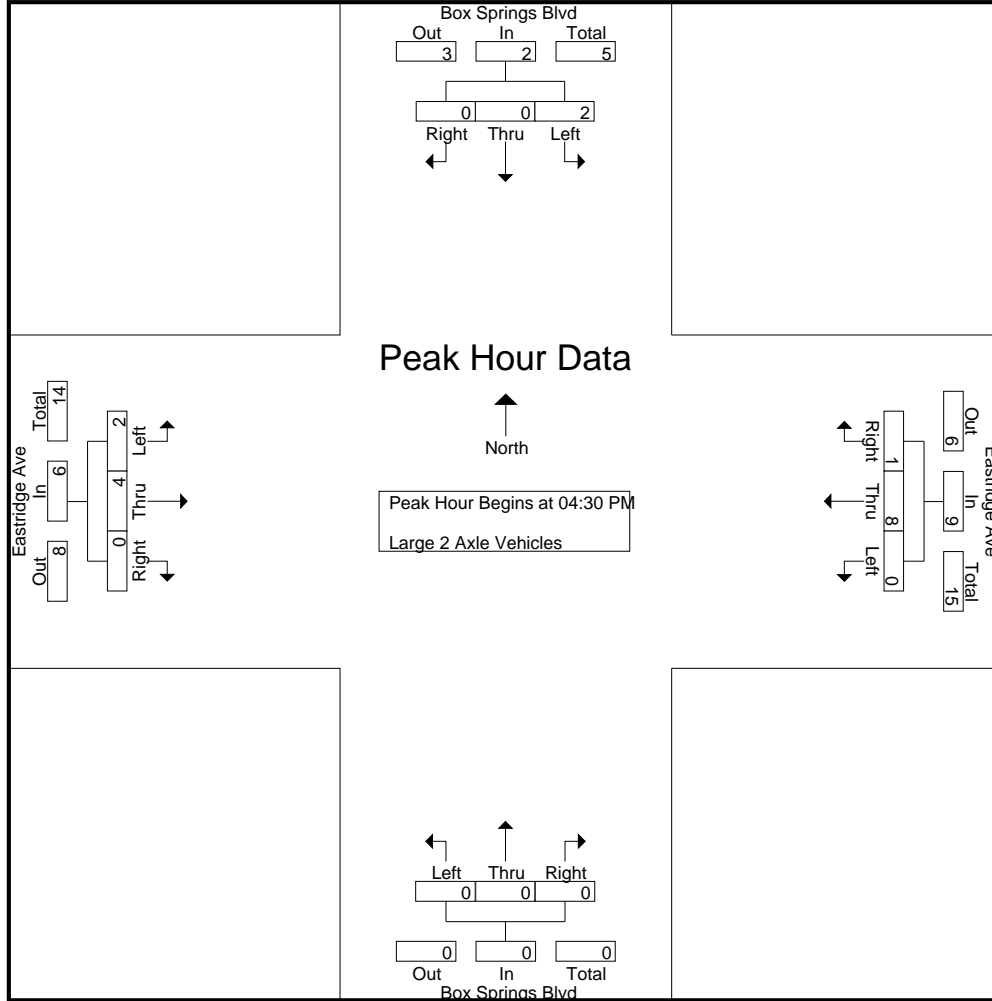

Peak Hour Analysis From 04:30 PM to 05:15 PM - Peak 1 of 1
 Peak Hour for Each Approach Begins at:

	04:30 PM				04:30 PM				04:30 PM				04:30 PM			
+0 mins.	1	0	0	1	0	1	0	1	0	0	0	0	1	2	0	3
+15 mins.	1	0	0	1	0	2	0	2	0	0	0	0	1	0	0	1
+30 mins.	0	0	0	0	0	1	0	1	0	0	0	0	0	0	0	0
+45 mins.	0	0	0	0	0	4	1	5	0	0	0	0	0	2	0	2
Total Volume	2	0	0	2	0	8	1	9	0	0	0	0	2	4	0	6
% App. Total	100	0	0	0	0	88.9	11.1	0	0	0	0	0	33.3	66.7	0	0
PHF	.500	.000	.000	.500	.000	.500	.250	.450	.000	.000	.000	.000	.500	.500	.000	.500

Counts Unlimited Inc
PO Box 1178
Corona, CA 92878
(951) 268-6268

City of Riverside
N/S: Box Springs Blvd
E/W: Eastridge Ave
Weather: Clear

File Name : RIVBBERPM
Site Code : 06715392
Start Date : 7/7/2015
Page No : 1

Groups Printed- 3 Axle Vehicles

Start Time	Box Springs Blvd Southbound				Eastridge Ave Westbound				Box Springs Blvd Northbound				Eastridge Ave Eastbound				Int. Total
	Left	Thru	Right	App. Total	Left	Thru	Right	App. Total	Left	Thru	Right	App. Total	Left	Thru	Right	App. Total	
04:00 PM	0	0	0	0	0	2	0	2	0	0	0	0	0	0	0	0	2
04:15 PM	0	0	0	0	0	1	0	1	0	0	0	0	0	0	0	0	1
04:30 PM	0	0	0	0	0	0	0	0	0	0	0	0	0	0	0	0	0
04:45 PM	0	0	0	0	1	0	0	1	0	0	0	0	0	1	0	1	2
Total	0	0	0	0	1	3	0	4	0	0	0	0	0	1	0	1	5
05:00 PM	0	1	0	1	0	1	0	1	0	0	0	0	0	0	0	0	2
05:15 PM	0	0	0	0	0	0	0	0	0	0	0	0	0	1	0	1	1
05:30 PM	0	0	0	0	0	0	0	0	0	0	0	0	0	2	0	2	2
05:45 PM	0	0	0	0	0	0	0	0	0	2	0	2	0	0	0	0	2
Total	0	1	0	1	0	1	0	1	0	2	0	2	0	3	0	3	7
Grand Total	0	1	0	1	1	4	0	5	0	2	0	2	0	4	0	4	12
Apprch %	0	100	0		20	80	0		0	100	0		0	100	0		
Total %	0	8.3	0	8.3	8.3	33.3	0	41.7	0	16.7	0	16.7	0	33.3	0	33.3	

Start Time	Box Springs Blvd Southbound				Eastridge Ave Westbound				Box Springs Blvd Northbound				Eastridge Ave Eastbound				Int. Total
	Left	Thru	Right	App. Total	Left	Thru	Right	App. Total	Left	Thru	Right	App. Total	Left	Thru	Right	App. Total	
Peak Hour Analysis From 04:30 PM to 05:15 PM - Peak 1 of 1																	
Peak Hour for Entire Intersection Begins at 04:30 PM																	
04:30 PM	0	0	0	0	0	0	0	0	0	0	0	0	0	0	0	0	0
04:45 PM	0	0	0	0	1	0	0	1	0	0	0	0	0	1	0	1	2
05:00 PM	0	1	0	1	0	1	0	1	0	0	0	0	0	0	0	0	2
05:15 PM	0	0	0	0	0	0	0	0	0	0	0	0	0	1	0	1	1
Total Volume	0	1	0	1	1	1	0	2	0	0	0	0	0	2	0	2	5
% App. Total	0	100	0		50	50	0		0	0	0		0	100	0		
PHF	.000	.250	.000	.250	.250	.250	.000	.500	.000	.000	.000	.000	.000	.500	.000	.500	.625

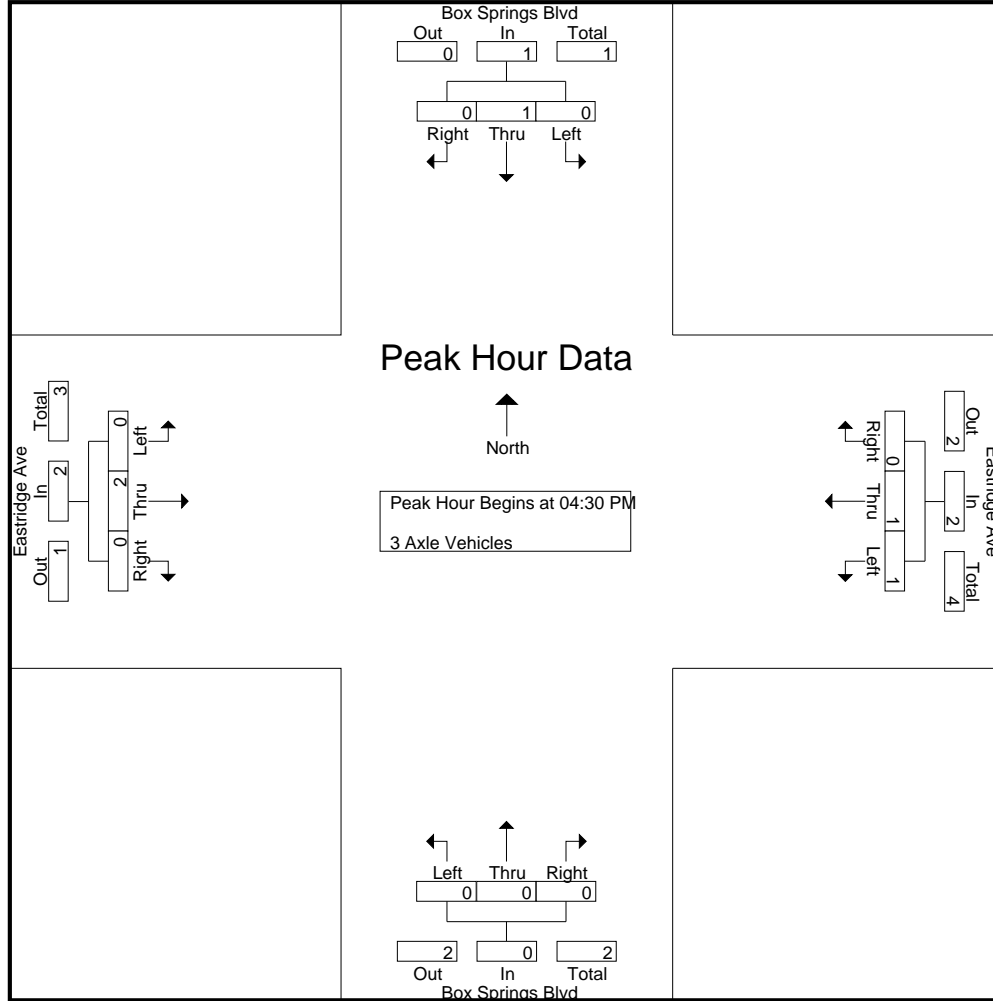

Peak Hour Analysis From 04:30 PM to 05:15 PM - Peak 1 of 1
 Peak Hour for Each Approach Begins at:

	04:30 PM				04:30 PM				04:30 PM				04:30 PM			
+0 mins.	0	0	0	0	0	0	0	0	0	0	0	0	0	0	0	0
+15 mins.	0	0	0	0	1	0	0	1	0	0	0	0	0	1	0	1
+30 mins.	0	1	0	1	0	1	0	1	0	0	0	0	0	0	0	0
+45 mins.	0	0	0	0	0	0	0	0	0	0	0	0	0	1	0	1
Total Volume	0	1	0	1	1	1	0	2	0	0	0	0	0	2	0	2
% App. Total	0	100	0	0	50	50	0	0	0	0	0	0	0	100	0	0
PHF	.000	.250	.000	.250	.250	.250	.000	.500	.000	.000	.000	.000	.000	.500	.000	.500

Counts Unlimited Inc
 PO Box 1178
 Corona, CA 92878
 (951) 268-6268

City of Riverside
 N/S: Box Springs Blvd
 E/W: Eastridge Ave
 Weather: Clear

File Name : RIVBBERPM
 Site Code : 06715392
 Start Date : 7/7/2015
 Page No : 1

Groups Printed- 4+ Axle Trucks

Start Time	Box Springs Blvd Southbound				Eastridge Ave Westbound				Box Springs Blvd Northbound				Eastridge Ave Eastbound				Int. Total
	Left	Thru	Right	App. Total	Left	Thru	Right	App. Total	Left	Thru	Right	App. Total	Left	Thru	Right	App. Total	
04:00 PM	0	0	0	0	1	4	0	5	0	0	0	0	0	10	1	11	16
04:15 PM	1	0	0	1	0	5	1	6	0	1	0	1	1	8	1	10	18
04:30 PM	1	0	0	1	2	3	1	6	1	0	0	1	0	9	0	9	17
04:45 PM	0	1	0	1	0	9	2	11	0	1	0	1	1	8	0	9	22
Total	2	1	0	3	3	21	4	28	1	2	0	3	2	35	2	39	73
05:00 PM	0	0	0	0	1	3	1	5	0	1	0	1	1	9	0	10	16
05:15 PM	0	0	0	0	1	6	0	7	0	0	0	0	0	5	0	5	12
05:30 PM	0	0	0	0	2	5	1	8	0	0	0	0	0	7	0	7	15
05:45 PM	0	0	0	0	0	8	0	8	0	0	0	0	0	4	0	4	12
Total	0	0	0	0	4	22	2	28	0	1	0	1	1	25	0	26	55
Grand Total	2	1	0	3	7	43	6	56	1	3	0	4	3	60	2	65	128
Apprch %	66.7	33.3	0		12.5	76.8	10.7		25	75	0		4.6	92.3	3.1		
Total %	1.6	0.8	0	2.3	5.5	33.6	4.7	43.8	0.8	2.3	0	3.1	2.3	46.9	1.6	50.8	

Start Time	Box Springs Blvd Southbound				Eastridge Ave Westbound				Box Springs Blvd Northbound				Eastridge Ave Eastbound				Int. Total
	Left	Thru	Right	App. Total	Left	Thru	Right	App. Total	Left	Thru	Right	App. Total	Left	Thru	Right	App. Total	
Peak Hour Analysis From 04:30 PM to 05:15 PM - Peak 1 of 1																	
Peak Hour for Entire Intersection Begins at 04:30 PM																	
04:30 PM	1	0	0	1	2	3	1	6	1	0	0	1	0	9	0	9	17
04:45 PM	0	1	0	1	0	9	2	11	0	1	0	1	1	8	0	9	22
05:00 PM	0	0	0	0	1	3	1	5	0	1	0	1	1	9	0	10	16
05:15 PM	0	0	0	0	1	6	0	7	0	0	0	0	0	5	0	5	12
Total Volume	1	1	0	2	4	21	4	29	1	2	0	3	2	31	0	33	67
% App. Total	50	50	0		13.8	72.4	13.8		33.3	66.7	0		6.1	93.9	0		
PHF	.250	.250	.000	.500	.500	.583	.500	.659	.250	.500	.000	.750	.500	.861	.000	.825	.761

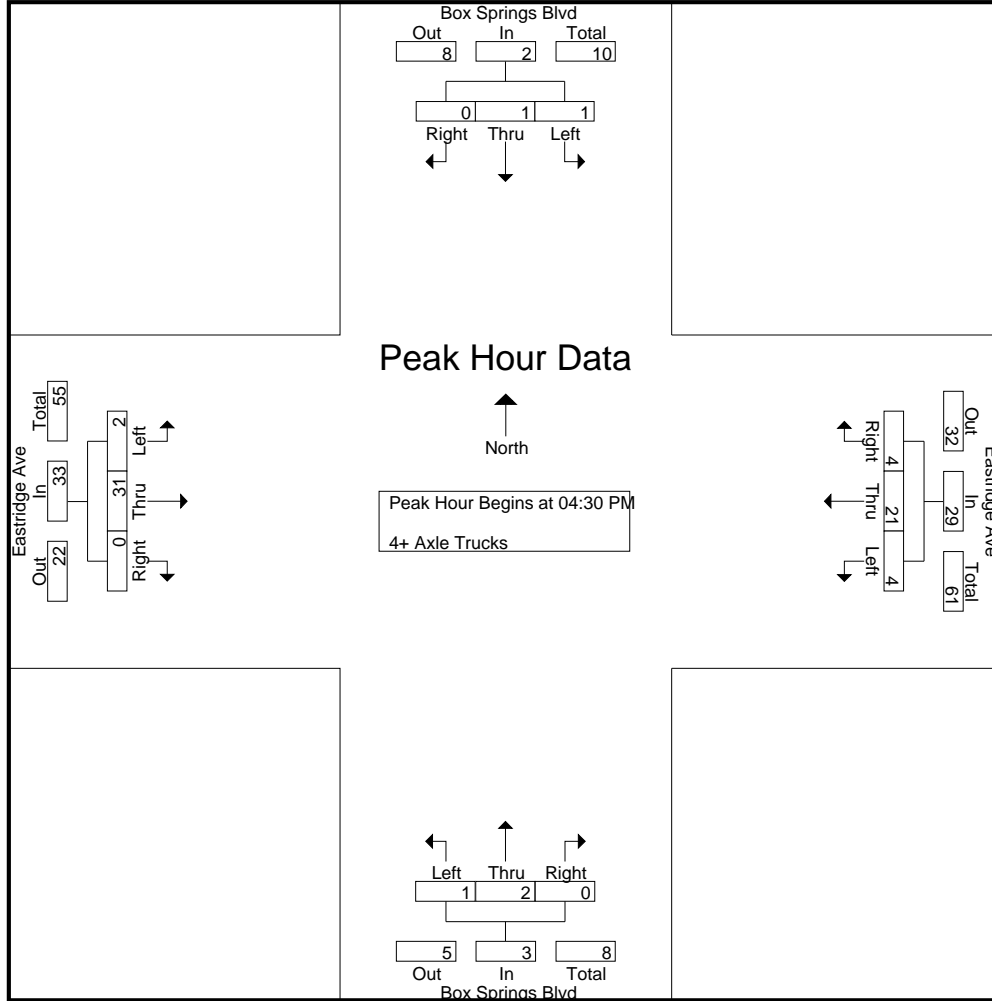

Peak Hour Analysis From 04:30 PM to 05:15 PM - Peak 1 of 1
 Peak Hour for Each Approach Begins at:

	04:30 PM				04:30 PM				04:30 PM				04:30 PM			
+0 mins.	1	0	0	1	2	3	1	6	1	0	0	1	0	9	0	9
+15 mins.	0	1	0	1	0	9	2	11	0	1	0	1	1	8	0	9
+30 mins.	0	0	0	0	1	3	1	5	0	1	0	1	1	9	0	10
+45 mins.	0	0	0	0	1	6	0	7	0	0	0	0	0	5	0	5
Total Volume	1	1	0	2	4	21	4	29	1	2	0	3	2	31	0	33
% App. Total	50	50	0		13.8	72.4	13.8		33.3	66.7	0		6.1	93.9	0	
PHF	.250	.250	.000	.500	.500	.583	.500	.659	.250	.500	.000	.750	.500	.861	.000	.825

Counts Unlimited Inc
PO Box 1178
Corona, CA 92878
(951) 268-6268

City of Riverside
 N/S: I-215 Ramps
 E/W: Eastridge Ave
 Weather: Clear

File Name : RIV215ERAM
 Site Code : 06715392
 Start Date : 7/7/2015
 Page No : 1

Groups Printed- Passenger Vehicles - Large 2 Axle Vehicles - 3 Axle Vehicles - 4+ Axle Trucks

Start Time	215 Ramp Southbound				Eastridge Ave Westbound				215 Ramp Northbound				Eastridge Ave Eastbound				Int. Total
	Left	Thru	Right	App. Total	Left	Thru	Right	App. Total	Left	Thru	Right	App. Total	Left	Thru	Right	App. Total	
07:00 AM	27	0	47	74	40	76	56	172	110	0	42	152	19	11	7	37	435
07:15 AM	33	0	49	82	66	98	75	239	108	0	41	149	12	14	21	47	517
07:30 AM	33	0	47	80	78	127	66	271	113	0	45	158	14	27	15	56	565
07:45 AM	38	0	49	87	62	124	54	240	102	0	52	154	16	26	18	60	541
Total	131	0	192	323	246	425	251	922	433	0	180	613	61	78	61	200	2058
08:00 AM	27	0	58	85	69	98	46	213	81	0	42	123	18	28	11	57	478
08:15 AM	27	0	45	72	48	61	41	150	68	0	42	110	12	22	21	55	387
08:30 AM	31	1	44	76	40	44	62	146	58	0	58	116	20	47	20	87	425
08:45 AM	29	0	51	80	72	48	44	164	60	0	81	141	21	21	8	50	435
Total	114	1	198	313	229	251	193	673	267	0	223	490	71	118	60	249	1725
Grand Total	245	1	390	636	475	676	444	1595	700	0	403	1103	132	196	121	449	3783
Apprch %	38.5	0.2	61.3		29.8	42.4	27.8		63.5	0	36.5		29.4	43.7	26.9		
Total %	6.5	0	10.3	16.8	12.6	17.9	11.7	42.2	18.5	0	10.7	29.2	3.5	5.2	3.2	11.9	
Passenger Vehicles	225	0	295	520	457	664	429	1550	675	0	392	1067	67	183	97	347	3484
% Passenger Vehicles	91.8	0	75.6	81.8	96.2	98.2	96.6	97.2	96.4	0	97.3	96.7	50.8	93.4	80.2	77.3	92.1
Large 2 Axle Vehicles	8	0	20	28	14	11	5	30	6	0	4	10	10	10	8	28	96
% Large 2 Axle Vehicles	3.3	0	5.1	4.4	2.9	1.6	1.1	1.9	0.9	0	1	0.9	7.6	5.1	6.6	6.2	2.5
3 Axle Vehicles	0	0	5	5	0	1	3	4	0	0	2	2	0	0	1	1	12
% 3 Axle Vehicles	0	0	1.3	0.8	0	0.1	0.7	0.3	0	0	0.5	0.2	0	0	0.8	0.2	0.3
4+ Axle Trucks	12	1	70	83	4	0	7	11	19	0	5	24	55	3	15	73	191
% 4+ Axle Trucks	4.9	100	17.9	13.1	0.8	0	1.6	0.7	2.7	0	1.2	2.2	41.7	1.5	12.4	16.3	5

Start Time	215 Ramp Southbound				Eastridge Ave Westbound				215 Ramp Northbound				Eastridge Ave Eastbound				Int. Total
	Left	Thru	Right	App. Total	Left	Thru	Right	App. Total	Left	Thru	Right	App. Total	Left	Thru	Right	App. Total	
Peak Hour Analysis From 07:00 AM to 08:45 AM - Peak 1 of 1																	
Peak Hour for Entire Intersection Begins at 07:15 AM																	
07:15 AM	33	0	49	82	66	98	75	239	108	0	41	149	12	14	21	47	517
07:30 AM	33	0	47	80	78	127	66	271	113	0	45	158	14	27	15	56	565
07:45 AM	38	0	49	87	62	124	54	240	102	0	52	154	16	26	18	60	541
08:00 AM	27	0	58	85	69	98	46	213	81	0	42	123	18	28	11	57	478
Total Volume	131	0	203	334	275	447	241	963	404	0	180	584	60	95	65	220	2101
% App. Total	39.2	0	60.8		28.6	46.4	25		69.2	0	30.8		27.3	43.2	29.5		
PHF	.862	.000	.875	.960	.881	.880	.803	.888	.894	.000	.865	.924	.833	.848	.774	.917	.930

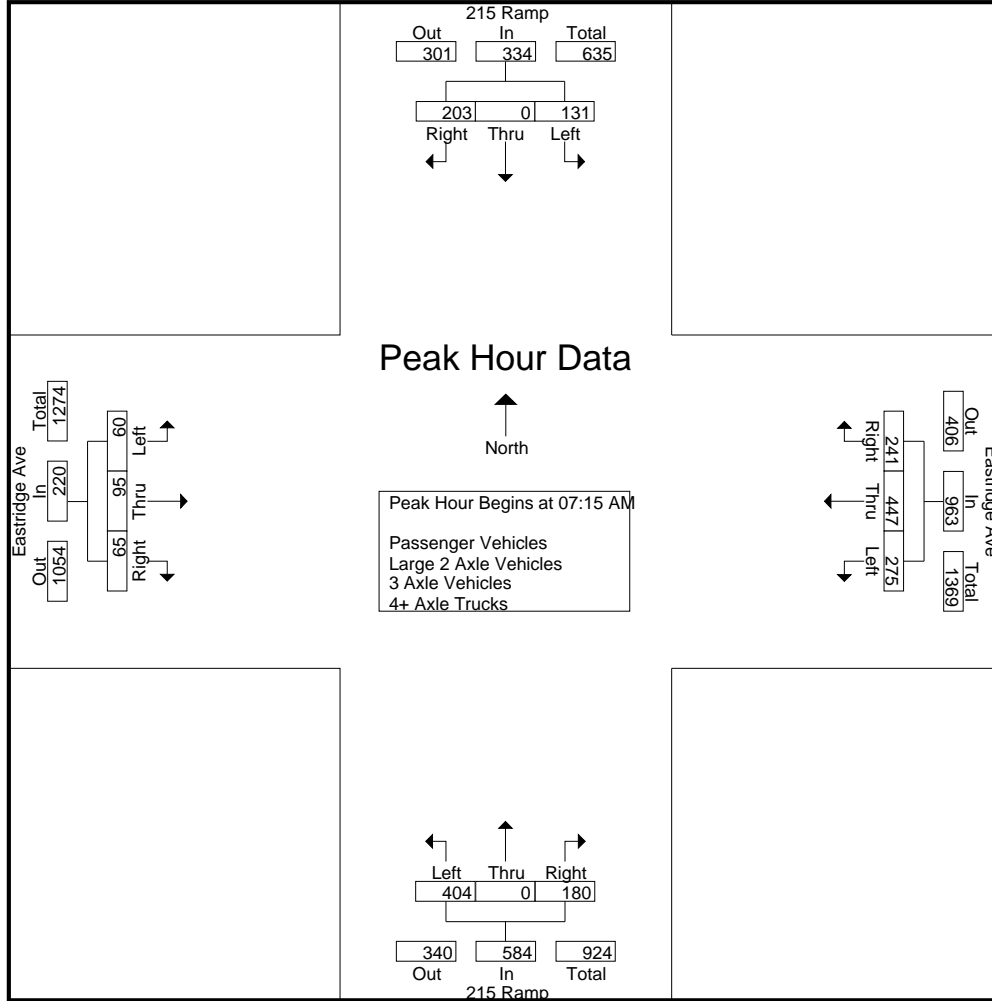

Peak Hour Analysis From 07:00 AM to 08:45 AM - Peak 1 of 1
 Peak Hour for Each Approach Begins at:

	07:15 AM				07:15 AM				07:00 AM				07:45 AM			
+0 mins.	33	0	49	82	66	98	75	239	110	0	42	152	16	26	18	60
+15 mins.	33	0	47	80	78	127	66	271	108	0	41	149	18	28	11	57
+30 mins.	38	0	49	87	62	124	54	240	113	0	45	158	12	22	21	55
+45 mins.	27	0	58	85	69	98	46	213	102	0	52	154	20	47	20	87
Total Volume	131	0	203	334	275	447	241	963	433	0	180	613	66	123	70	259
% App. Total	39.2	0	60.8		28.6	46.4	25		70.6	0	29.4		25.5	47.5	27	
PHF	.862	.000	.875	.960	.881	.880	.803	.888	.958	.000	.865	.970	.825	.654	.833	.744

Counts Unlimited Inc
PO Box 1178
Corona, CA 92878
(951) 268-6268

City of Riverside
N/S: I-215 Ramps
E/W: Eastridge Ave
Weather: Clear

File Name : RIV215ERAM
Site Code : 06715392
Start Date : 7/7/2015
Page No : 1

Groups Printed- Passenger Vehicles

Start Time	215 Ramp Southbound				Eastridge Ave Westbound				215 Ramp Northbound				Eastridge Ave Eastbound				Int. Total
	Left	Thru	Right	App. Total	Left	Thru	Right	App. Total	Left	Thru	Right	App. Total	Left	Thru	Right	App. Total	
07:00 AM	27	0	33	60	38	76	55	169	107	0	42	149	14	10	4	28	406
07:15 AM	30	0	36	66	62	97	73	232	102	0	40	142	6	14	19	39	479
07:30 AM	30	0	40	70	76	127	64	267	109	0	43	152	8	23	13	44	533
07:45 AM	36	0	41	77	59	122	52	233	99	0	50	149	6	25	14	45	504
Total	123	0	150	273	235	422	244	901	417	0	175	592	34	72	50	156	1922
08:00 AM	25	0	39	64	67	97	43	207	78	0	42	120	7	28	9	44	435
08:15 AM	25	0	29	54	44	60	37	141	68	0	40	108	6	19	14	39	342
08:30 AM	27	0	35	62	39	43	61	143	56	0	56	112	8	47	17	72	389
08:45 AM	25	0	42	67	72	42	44	158	56	0	79	135	12	17	7	36	396
Total	102	0	145	247	222	242	185	649	258	0	217	475	33	111	47	191	1562
Grand Total	225	0	295	520	457	664	429	1550	675	0	392	1067	67	183	97	347	3484
Apprch %	43.3	0	56.7		29.5	42.8	27.7		63.3	0	36.7		19.3	52.7	28		
Total %	6.5	0	8.5	14.9	13.1	19.1	12.3	44.5	19.4	0	11.3	30.6	1.9	5.3	2.8	10	

Start Time	215 Ramp Southbound				Eastridge Ave Westbound				215 Ramp Northbound				Eastridge Ave Eastbound				Int. Total
	Left	Thru	Right	App. Total	Left	Thru	Right	App. Total	Left	Thru	Right	App. Total	Left	Thru	Right	App. Total	
Peak Hour Analysis From 07:15 AM to 08:00 AM - Peak 1 of 1																	
Peak Hour for Entire Intersection Begins at 07:15 AM																	
07:15 AM	30	0	36	66	62	97	73	232	102	0	40	142	6	14	19	39	479
07:30 AM	30	0	40	70	76	127	64	267	109	0	43	152	8	23	13	44	533
07:45 AM	36	0	41	77	59	122	52	233	99	0	50	149	6	25	14	45	504
08:00 AM	25	0	39	64	67	97	43	207	78	0	42	120	7	28	9	44	435
Total Volume	121	0	156	277	264	443	232	939	388	0	175	563	27	90	55	172	1951
% App. Total	43.7	0	56.3		28.1	47.2	24.7		68.9	0	31.1		15.7	52.3	32		
PHF	.840	.000	.951	.899	.868	.872	.795	.879	.890	.000	.875	.926	.844	.804	.724	.956	.915

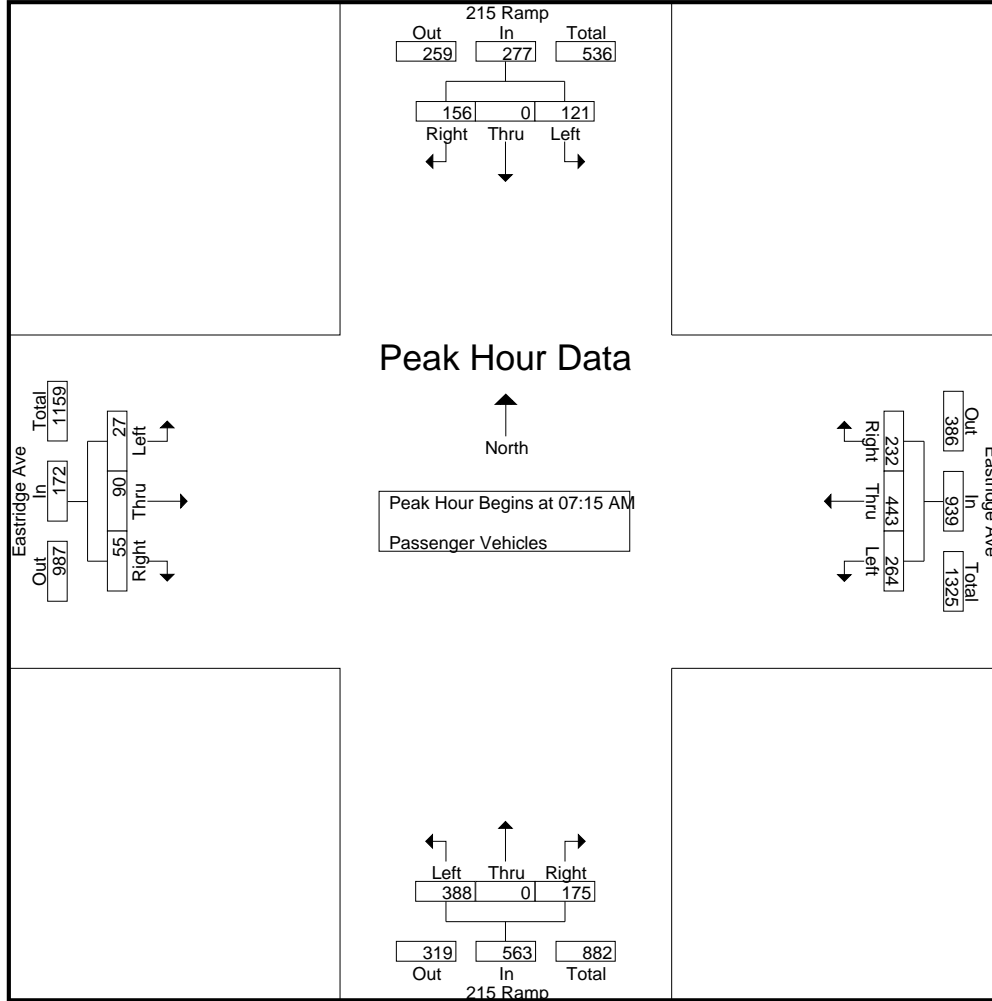

Peak Hour Analysis From 07:15 AM to 08:00 AM - Peak 1 of 1
 Peak Hour for Each Approach Begins at:

	07:15 AM				07:15 AM				07:15 AM				07:15 AM			
+0 mins.	30	0	36	66	62	97	73	232	102	0	40	142	6	14	19	39
+15 mins.	30	0	40	70	76	127	64	267	109	0	43	152	8	23	13	44
+30 mins.	36	0	41	77	59	122	52	233	99	0	50	149	6	25	14	45
+45 mins.	25	0	39	64	67	97	43	207	78	0	42	120	7	28	9	44
Total Volume	121	0	156	277	264	443	232	939	388	0	175	563	27	90	55	172
% App. Total	43.7	0	56.3		28.1	47.2	24.7		68.9	0	31.1		15.7	52.3	32	
PHF	.840	.000	.951	.899	.868	.872	.795	.879	.890	.000	.875	.926	.844	.804	.724	.956

Counts Unlimited Inc
 PO Box 1178
 Corona, CA 92878
 (951) 268-6268

City of Riverside
 N/S: I-215 Ramps
 E/W: Eastridge Ave
 Weather: Clear

File Name : RIV215ERAM
 Site Code : 06715392
 Start Date : 7/7/2015
 Page No : 1

Groups Printed- Large 2 Axle Vehicles

Start Time	215 Ramp Southbound				Eastridge Ave Westbound				215 Ramp Northbound				Eastridge Ave Eastbound				Int. Total
	Left	Thru	Right	App. Total	Left	Thru	Right	App. Total	Left	Thru	Right	App. Total	Left	Thru	Right	App. Total	
07:00 AM	0	0	1	1	2	0	0	2	0	0	0	0	0	1	1	2	5
07:15 AM	2	0	2	4	4	1	1	6	1	0	1	2	1	0	0	1	13
07:30 AM	1	0	1	2	2	0	2	4	2	0	0	2	1	3	1	5	13
07:45 AM	1	0	2	3	2	2	0	4	0	0	1	1	0	1	0	1	9
Total	4	0	6	10	10	3	3	16	3	0	2	5	2	5	2	9	40
08:00 AM	0	0	6	6	1	1	0	2	1	0	0	1	1	0	1	2	11
08:15 AM	0	0	4	4	3	0	1	4	0	0	0	0	0	1	4	5	13
08:30 AM	1	0	2	3	0	1	1	2	0	0	1	1	4	0	1	5	11
08:45 AM	3	0	2	5	0	6	0	6	2	0	1	3	3	4	0	7	21
Total	4	0	14	18	4	8	2	14	3	0	2	5	8	5	6	19	56
Grand Total	8	0	20	28	14	11	5	30	6	0	4	10	10	10	8	28	96
Apprch %	28.6	0	71.4		46.7	36.7	16.7		60	0	40		35.7	35.7	28.6		
Total %	8.3	0	20.8	29.2	14.6	11.5	5.2	31.2	6.2	0	4.2	10.4	10.4	10.4	8.3	29.2	

Start Time	215 Ramp Southbound				Eastridge Ave Westbound				215 Ramp Northbound				Eastridge Ave Eastbound				Int. Total
	Left	Thru	Right	App. Total	Left	Thru	Right	App. Total	Left	Thru	Right	App. Total	Left	Thru	Right	App. Total	
Peak Hour Analysis From 07:15 AM to 08:00 AM - Peak 1 of 1																	
Peak Hour for Entire Intersection Begins at 07:15 AM																	
07:15 AM	2	0	2	4	4	1	1	6	1	0	1	2	1	0	0	1	13
07:30 AM	1	0	1	2	2	0	2	4	2	0	0	2	1	3	1	5	13
07:45 AM	1	0	2	3	2	2	0	4	0	0	1	1	0	1	0	1	9
08:00 AM	0	0	6	6	1	1	0	2	1	0	0	1	1	0	1	2	11
Total Volume	4	0	11	15	9	4	3	16	4	0	2	6	3	4	2	9	46
% App. Total	26.7	0	73.3		56.2	25	18.8		66.7	0	33.3		33.3	44.4	22.2		
PHF	.500	.000	.458	.625	.563	.500	.375	.667	.500	.000	.500	.750	.750	.333	.500	.450	.885

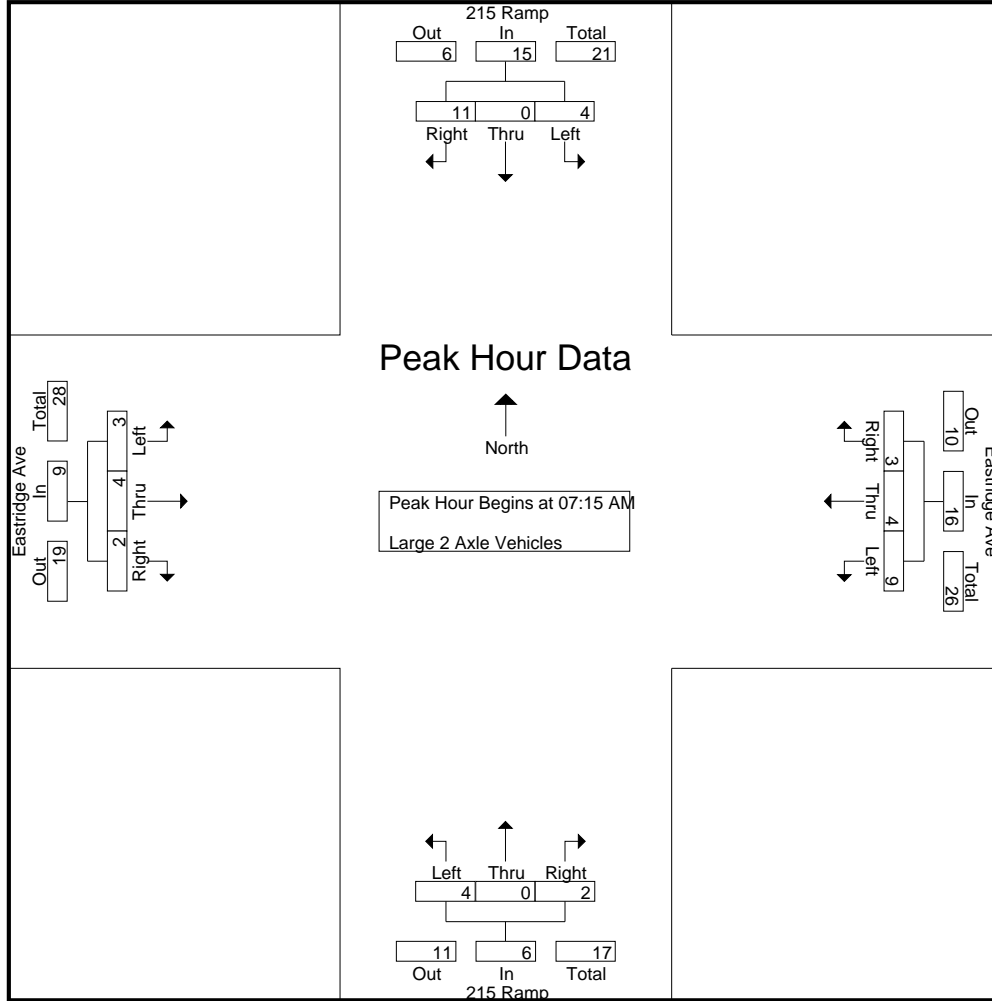

Peak Hour Analysis From 07:15 AM to 08:00 AM - Peak 1 of 1
 Peak Hour for Each Approach Begins at:

	07:15 AM				07:15 AM				07:15 AM				07:15 AM			
+0 mins.	2	0	2	4	4	1	1	6	1	0	1	2	1	0	0	1
+15 mins.	1	0	1	2	2	0	2	4	2	0	0	2	1	3	1	5
+30 mins.	1	0	2	3	2	2	0	4	0	0	1	1	0	1	0	1
+45 mins.	0	0	6	6	1	1	0	2	1	0	0	1	1	0	1	2
Total Volume	4	0	11	15	9	4	3	16	4	0	2	6	3	4	2	9
% App. Total	26.7	0	73.3		56.2	25	18.8		66.7	0	33.3		33.3	44.4	22.2	
PHF	.500	.000	.458	.625	.563	.500	.375	.667	.500	.000	.500	.750	.750	.333	.500	.450

Counts Unlimited Inc
 PO Box 1178
 Corona, CA 92878
 (951) 268-6268

City of Riverside
 N/S: I-215 Ramps
 E/W: Eastridge Ave
 Weather: Clear

File Name : RIV215ERAM
 Site Code : 06715392
 Start Date : 7/7/2015
 Page No : 1

Groups Printed- 3 Axle Vehicles

Start Time	215 Ramp Southbound				Eastridge Ave Westbound				215 Ramp Northbound				Eastridge Ave Eastbound				Int. Total	
	Left	Thru	Right	App. Total	Left	Thru	Right	App. Total	Left	Thru	Right	App. Total	Left	Thru	Right	App. Total		
07:00 AM	0	0	1	1	0	0	0	0	0	0	0	0	0	0	0	0	0	1
07:15 AM	0	0	1	1	0	0	1	1	0	0	0	0	0	0	1	1	1	3
07:30 AM	0	0	0	0	0	0	0	0	0	0	0	0	0	0	0	0	0	0
07:45 AM	0	0	1	1	0	0	0	0	0	0	0	0	0	0	0	0	0	1
Total	0	0	3	3	0	0	1	1	0	0	0	0	0	0	1	1	1	5
08:00 AM	0	0	1	1	0	0	0	0	0	0	0	0	0	0	0	0	0	1
08:15 AM	0	0	1	1	0	1	2	3	0	0	1	1	0	0	0	0	0	5
08:30 AM	0	0	0	0	0	0	0	0	0	0	1	1	0	0	0	0	0	1
08:45 AM	0	0	0	0	0	0	0	0	0	0	0	0	0	0	0	0	0	0
Total	0	0	2	2	0	1	2	3	0	0	2	2	0	0	0	0	0	7
Grand Total	0	0	5	5	0	1	3	4	0	0	2	2	0	0	1	1	1	12
Apprch %	0	0	100		0	25	75		0	0	100		0	0	100			
Total %	0	0	41.7	41.7	0	8.3	25	33.3	0	0	16.7	16.7	0	0	8.3	8.3		

Start Time	215 Ramp Southbound				Eastridge Ave Westbound				215 Ramp Northbound				Eastridge Ave Eastbound				Int. Total	
	Left	Thru	Right	App. Total	Left	Thru	Right	App. Total	Left	Thru	Right	App. Total	Left	Thru	Right	App. Total		
Peak Hour Analysis From 07:15 AM to 08:00 AM - Peak 1 of 1																		
Peak Hour for Entire Intersection Begins at 07:15 AM																		
07:15 AM	0	0	1	1	0	0	1	1	0	0	0	0	0	0	1	1	1	3
07:30 AM	0	0	0	0	0	0	0	0	0	0	0	0	0	0	0	0	0	0
07:45 AM	0	0	1	1	0	0	0	0	0	0	0	0	0	0	0	0	0	1
08:00 AM	0	0	1	1	0	0	0	0	0	0	0	0	0	0	0	0	0	1
Total Volume	0	0	3	3	0	0	1	1	0	0	0	0	0	0	1	1	1	5
% App. Total	0	0	100		0	0	100		0	0	0		0	0	100			
PHF	.000	.000	.750	.750	.000	.000	.250	.250	.000	.000	.000	.000	.000	.000	.250	.250	.417	

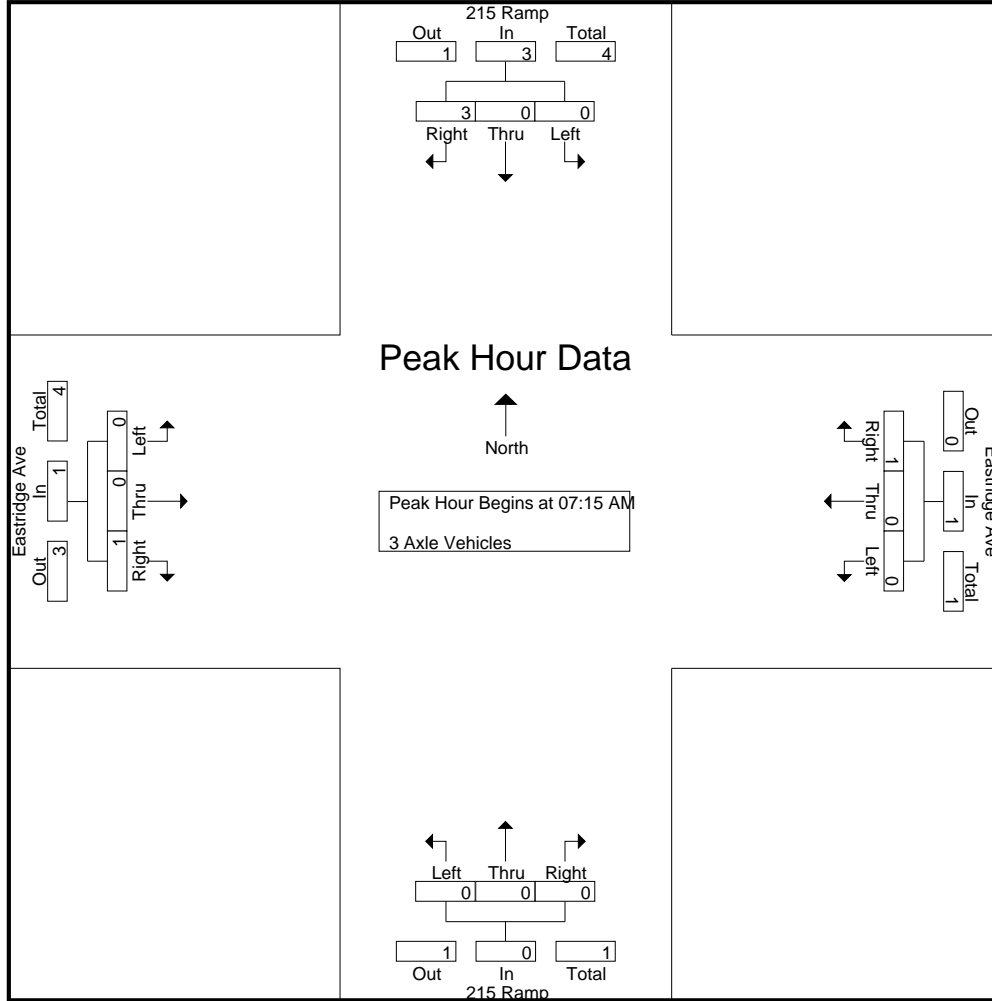

Peak Hour Analysis From 07:15 AM to 08:00 AM - Peak 1 of 1
 Peak Hour for Each Approach Begins at:

	07:15 AM				07:15 AM				07:15 AM				07:15 AM			
+0 mins.	0	0	1	1	0	0	1	1	0	0	0	0	0	0	1	1
+15 mins.	0	0	0	0	0	0	0	0	0	0	0	0	0	0	0	0
+30 mins.	0	0	1	1	0	0	0	0	0	0	0	0	0	0	0	0
+45 mins.	0	0	1	1	0	0	0	0	0	0	0	0	0	0	0	0
Total Volume	0	0	3	3	0	0	1	1	0	0	0	0	0	0	1	1
% App. Total	0	0	100		0	0	100		0	0	0		0	0	100	
PHF	.000	.000	.750	.750	.000	.000	.250	.250	.000	.000	.000	.000	.000	.000	.250	.250

Counts Unlimited Inc
 PO Box 1178
 Corona, CA 92878
 (951) 268-6268

City of Riverside
 N/S: I-215 Ramps
 E/W: Eastridge Ave
 Weather: Clear

File Name : RIV215ERAM
 Site Code : 06715392
 Start Date : 7/7/2015
 Page No : 1

Groups Printed- 4+ Axle Trucks

Start Time	215 Ramp Southbound				Eastridge Ave Westbound				215 Ramp Northbound				Eastridge Ave Eastbound				Int. Total
	Left	Thru	Right	App. Total	Left	Thru	Right	App. Total	Left	Thru	Right	App. Total	Left	Thru	Right	App. Total	
07:00 AM	0	0	12	12	0	0	1	1	3	0	0	3	5	0	2	7	23
07:15 AM	1	0	10	11	0	0	0	0	5	0	0	5	5	0	1	6	22
07:30 AM	2	0	6	8	0	0	0	0	2	0	2	4	5	1	1	7	19
07:45 AM	1	0	5	6	1	0	2	3	3	0	1	4	10	0	4	14	27
Total	4	0	33	37	1	0	3	4	13	0	3	16	25	1	8	34	91
08:00 AM	2	0	12	14	1	0	3	4	2	0	0	2	10	0	1	11	31
08:15 AM	2	0	11	13	1	0	1	2	0	0	1	1	6	2	3	11	27
08:30 AM	3	1	7	11	1	0	0	1	2	0	0	2	8	0	2	10	24
08:45 AM	1	0	7	8	0	0	0	0	2	0	1	3	6	0	1	7	18
Total	8	1	37	46	3	0	4	7	6	0	2	8	30	2	7	39	100
Grand Total	12	1	70	83	4	0	7	11	19	0	5	24	55	3	15	73	191
Apprch %	14.5	1.2	84.3		36.4	0	63.6		79.2	0	20.8		75.3	4.1	20.5		
Total %	6.3	0.5	36.6	43.5	2.1	0	3.7	5.8	9.9	0	2.6	12.6	28.8	1.6	7.9	38.2	

Start Time	215 Ramp Southbound				Eastridge Ave Westbound				215 Ramp Northbound				Eastridge Ave Eastbound				Int. Total
	Left	Thru	Right	App. Total	Left	Thru	Right	App. Total	Left	Thru	Right	App. Total	Left	Thru	Right	App. Total	
Peak Hour Analysis From 07:15 AM to 08:00 AM - Peak 1 of 1																	
Peak Hour for Entire Intersection Begins at 07:15 AM																	
07:15 AM	1	0	10	11	0	0	0	0	5	0	0	5	5	0	1	6	22
07:30 AM	2	0	6	8	0	0	0	0	2	0	2	4	5	1	1	7	19
07:45 AM	1	0	5	6	1	0	2	3	3	0	1	4	10	0	4	14	27
08:00 AM	2	0	12	14	1	0	3	4	2	0	0	2	10	0	1	11	31
Total Volume	6	0	33	39	2	0	5	7	12	0	3	15	30	1	7	38	99
% App. Total	15.4	0	84.6		28.6	0	71.4		80	0	20		78.9	2.6	18.4		
PHF	.750	.000	.688	.696	.500	.000	.417	.438	.600	.000	.375	.750	.750	.250	.438	.679	.798

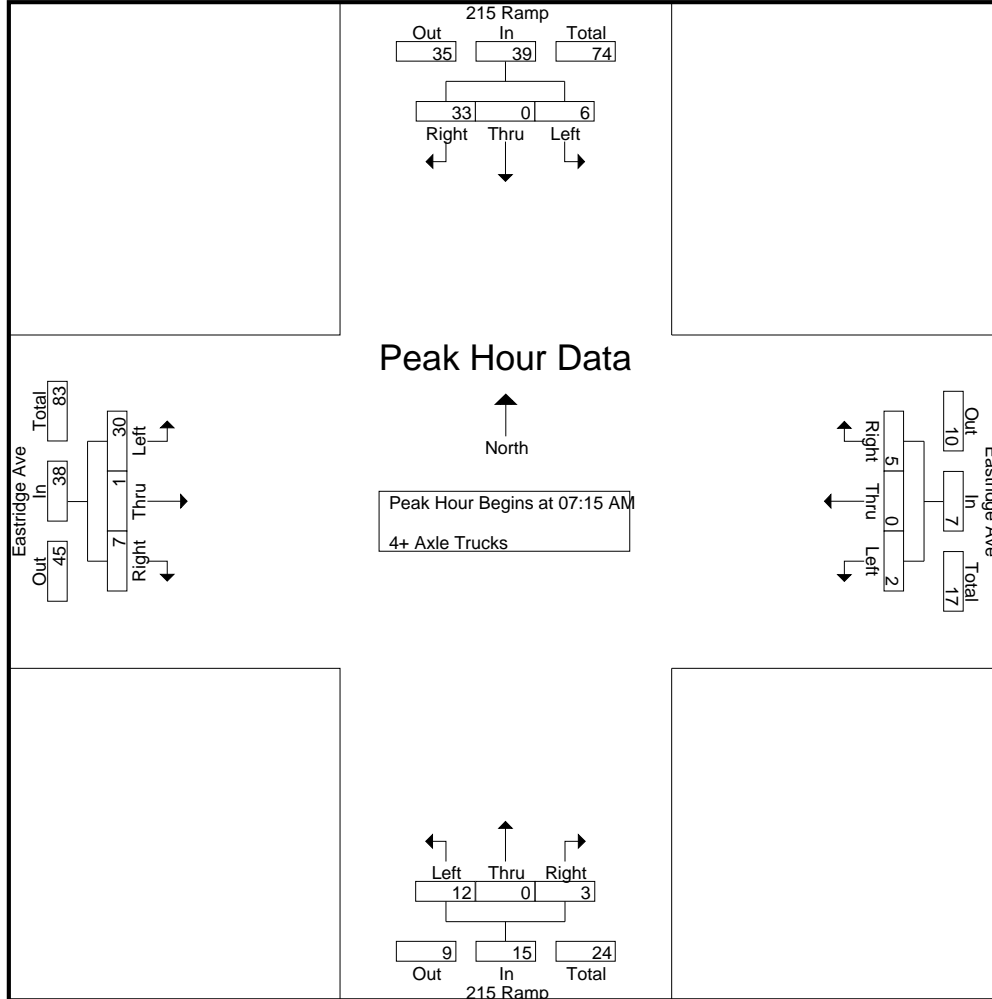

Peak Hour Analysis From 07:15 AM to 08:00 AM - Peak 1 of 1
 Peak Hour for Each Approach Begins at:

	07:15 AM				07:15 AM				07:15 AM				07:15 AM			
+0 mins.	1	0	10	11	0	0	0	0	5	0	0	5	5	0	1	6
+15 mins.	2	0	6	8	0	0	0	0	2	0	2	4	5	1	1	7
+30 mins.	1	0	5	6	1	0	2	3	3	0	1	4	10	0	4	14
+45 mins.	2	0	12	14	1	0	3	4	2	0	0	2	10	0	1	11
Total Volume	6	0	33	39	2	0	5	7	12	0	3	15	30	1	7	38
% App. Total	15.4	0	84.6		28.6	0	71.4		80	0	20		78.9	2.6	18.4	
PHF	.750	.000	.688	.696	.500	.000	.417	.438	.600	.000	.375	.750	.750	.250	.438	.679

Counts Unlimited Inc
 PO Box 1178
 Corona, CA 92878
 (951) 268-6268

City of Riverside
 N/S: I-215 Ramps
 E/W: Eastridge Ave
 Weather: Clear

File Name : RIV215ERPM
 Site Code : 06715392
 Start Date : 7/7/2015
 Page No : 1

Groups Printed- Passenger Vehicles - Large 2 Axle Vehicles - 3 Axle Vehicles - 4+ Axle Trucks

Start Time	215 Ramp Southbound				Eastridge Ave Westbound				215 Ramp Northbound				Eastridge Ave Eastbound				Int. Total
	Left	Thru	Right	App. Total	Left	Thru	Right	App. Total	Left	Thru	Right	App. Total	Left	Thru	Right	App. Total	
04:00 PM	87	0	27	114	169	63	92	324	29	0	131	160	44	83	52	179	777
04:15 PM	73	0	18	91	166	51	69	286	23	0	123	146	36	61	37	134	657
04:30 PM	100	0	26	126	164	60	80	304	28	0	113	141	49	84	56	189	760
04:45 PM	95	0	28	123	122	61	54	237	25	0	146	171	26	74	41	141	672
Total	355	0	99	454	621	235	295	1151	105	0	513	618	155	302	186	643	2866
05:00 PM	97	0	20	117	146	55	88	289	16	1	107	124	61	113	58	232	762
05:15 PM	135	1	24	160	127	48	70	245	25	0	139	164	35	67	27	129	698
05:30 PM	120	0	19	139	154	43	102	299	27	0	151	178	31	64	22	117	733
05:45 PM	93	0	25	118	137	52	69	258	17	0	137	154	12	57	20	89	619
Total	445	1	88	534	564	198	329	1091	85	1	534	620	139	301	127	567	2812
Grand Total	800	1	187	988	1185	433	624	2242	190	1	1047	1238	294	603	313	1210	5678
Apprch %	81	0.1	18.9		52.9	19.3	27.8		15.3	0.1	84.6		24.3	49.8	25.9		
Total %	14.1	0	3.3	17.4	20.9	7.6	11	39.5	3.3	0	18.4	21.8	5.2	10.6	5.5	21.3	
Passenger Vehicles	793	1	137	931	1178	422	616	2216	172	1	1034	1207	243	600	291	1134	5488
% Passenger Vehicles	99.1	100	73.3	94.2	99.4	97.5	98.7	98.8	90.5	100	98.8	97.5	82.7	99.5	93	93.7	96.7
Large 2 Axle Vehicles	5	0	3	8	7	8	6	21	6	0	11	17	3	1	3	7	53
% Large 2 Axle Vehicles	0.6	0	1.6	0.8	0.6	1.8	1	0.9	3.2	0	1.1	1.4	1	0.2	1	0.6	0.9
3 Axle Vehicles	0	0	3	3	0	1	0	1	0	0	1	1	0	0	2	2	7
% 3 Axle Vehicles	0	0	1.6	0.3	0	0.2	0	0	0	0	0.1	0.1	0	0	0.6	0.2	0.1
4+ Axle Trucks	2	0	44	46	0	2	2	4	12	0	1	13	48	2	17	67	130
% 4+ Axle Trucks	0.2	0	23.5	4.7	0	0.5	0.3	0.2	6.3	0	0.1	1.1	16.3	0.3	5.4	5.5	2.3

Start Time	215 Ramp Southbound				Eastridge Ave Westbound				215 Ramp Northbound				Eastridge Ave Eastbound				Int. Total
	Left	Thru	Right	App. Total	Left	Thru	Right	App. Total	Left	Thru	Right	App. Total	Left	Thru	Right	App. Total	
Peak Hour Analysis From 04:00 PM to 05:45 PM - Peak 1 of 1																	
Peak Hour for Entire Intersection Begins at 04:30 PM																	
04:30 PM	100	0	26	126	164	60	80	304	28	0	113	141	49	84	56	189	760
04:45 PM	95	0	28	123	122	61	54	237	25	0	146	171	26	74	41	141	672
05:00 PM	97	0	20	117	146	55	88	289	16	1	107	124	61	113	58	232	762
05:15 PM	135	1	24	160	127	48	70	245	25	0	139	164	35	67	27	129	698
Total Volume	427	1	98	526	559	224	292	1075	94	1	505	600	171	338	182	691	2892
% App. Total	81.2	0.2	18.6		52	20.8	27.2		15.7	0.2	84.2		24.7	48.9	26.3		
PHF	.791	.250	.875	.822	.852	.918	.830	.884	.839	.250	.865	.877	.701	.748	.784	.745	.949

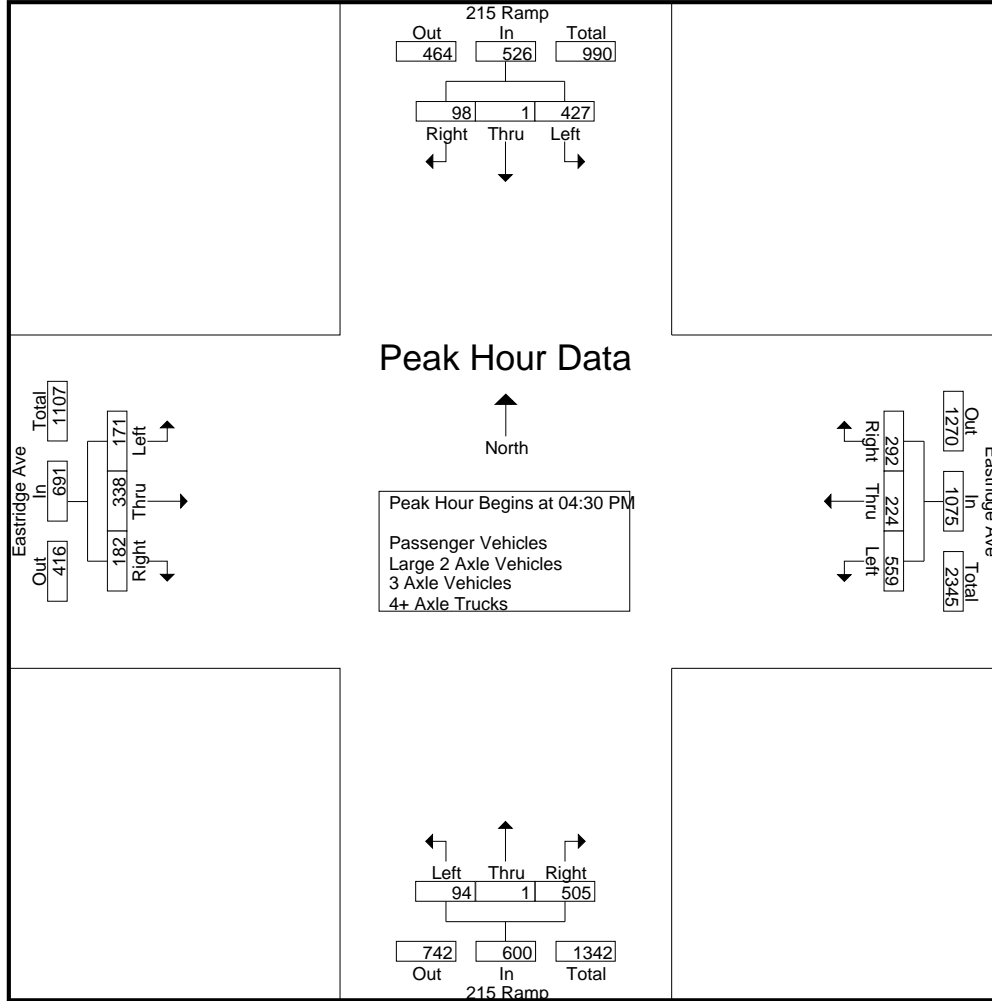

Peak Hour Analysis From 04:00 PM to 05:45 PM - Peak 1 of 1
 Peak Hour for Each Approach Begins at:

	04:45 PM				04:00 PM				04:45 PM				04:15 PM			
+0 mins.	95	0	28	123	169	63	92	324	25	0	146	171	36	61	37	134
+15 mins.	97	0	20	117	166	51	69	286	16	1	107	124	49	84	56	189
+30 mins.	135	1	24	160	164	60	80	304	25	0	139	164	26	74	41	141
+45 mins.	120	0	19	139	122	61	54	237	27	0	151	178	61	113	58	232
Total Volume	447	1	91	539	621	235	295	1151	93	1	543	637	172	332	192	696
% App. Total	82.9	0.2	16.9		54	20.4	25.6		14.6	0.2	85.2		24.7	47.7	27.6	
PHF	.828	.250	.813	.842	.919	.933	.802	.888	.861	.250	.899	.895	.705	.735	.828	.750

Counts Unlimited Inc
PO Box 1178
Corona, CA 92878
(951) 268-6268

City of Riverside
N/S: I-215 Ramps
E/W: Eastridge Ave
Weather: Clear

File Name : RIV215ERPM
Site Code : 06715392
Start Date : 7/7/2015
Page No : 1

Groups Printed- Passenger Vehicles

Start Time	215 Ramp Southbound				Eastridge Ave Westbound				215 Ramp Northbound				Eastridge Ave Eastbound				Int. Total
	Left	Thru	Right	App. Total	Left	Thru	Right	App. Total	Left	Thru	Right	App. Total	Left	Thru	Right	App. Total	
04:00 PM	86	0	21	107	166	61	92	319	26	0	129	155	39	82	48	169	750
04:15 PM	73	0	11	84	165	51	68	284	22	0	121	143	28	60	34	122	633
04:30 PM	100	0	20	120	164	60	79	303	26	0	112	138	38	84	52	174	735
04:45 PM	95	0	20	115	121	58	52	231	22	0	141	163	19	74	39	132	641
Total	354	0	72	426	616	230	291	1137	96	0	503	599	124	300	173	597	2759
05:00 PM	96	0	15	111	145	54	86	285	14	1	106	121	57	112	54	223	740
05:15 PM	133	1	19	153	127	47	70	244	22	0	138	160	30	67	26	123	680
05:30 PM	117	0	12	129	154	42	100	296	24	0	150	174	22	64	20	106	705
05:45 PM	93	0	19	112	136	49	69	254	16	0	137	153	10	57	18	85	604
Total	439	1	65	505	562	192	325	1079	76	1	531	608	119	300	118	537	2729
Grand Total	793	1	137	931	1178	422	616	2216	172	1	1034	1207	243	600	291	1134	5488
Apprch %	85.2	0.1	14.7		53.2	19	27.8		14.3	0.1	85.7		21.4	52.9	25.7		
Total %	14.4	0	2.5	17	21.5	7.7	11.2	40.4	3.1	0	18.8	22	4.4	10.9	5.3	20.7	

Start Time	215 Ramp Southbound				Eastridge Ave Westbound				215 Ramp Northbound				Eastridge Ave Eastbound				Int. Total
	Left	Thru	Right	App. Total	Left	Thru	Right	App. Total	Left	Thru	Right	App. Total	Left	Thru	Right	App. Total	
Peak Hour Analysis From 04:30 PM to 05:15 PM - Peak 1 of 1																	
Peak Hour for Entire Intersection Begins at 04:30 PM																	
04:30 PM	100	0	20	120	164	60	79	303	26	0	112	138	38	84	52	174	735
04:45 PM	95	0	20	115	121	58	52	231	22	0	141	163	19	74	39	132	641
05:00 PM	96	0	15	111	145	54	86	285	14	1	106	121	57	112	54	223	740
05:15 PM	133	1	19	153	127	47	70	244	22	0	138	160	30	67	26	123	680
Total Volume	424	1	74	499	557	219	287	1063	84	1	497	582	144	337	171	652	2796
% App. Total	85	0.2	14.8		52.4	20.6	27		14.4	0.2	85.4		22.1	51.7	26.2		
PHF	.797	.250	.925	.815	.849	.913	.834	.877	.808	.250	.881	.893	.632	.752	.792	.731	.945

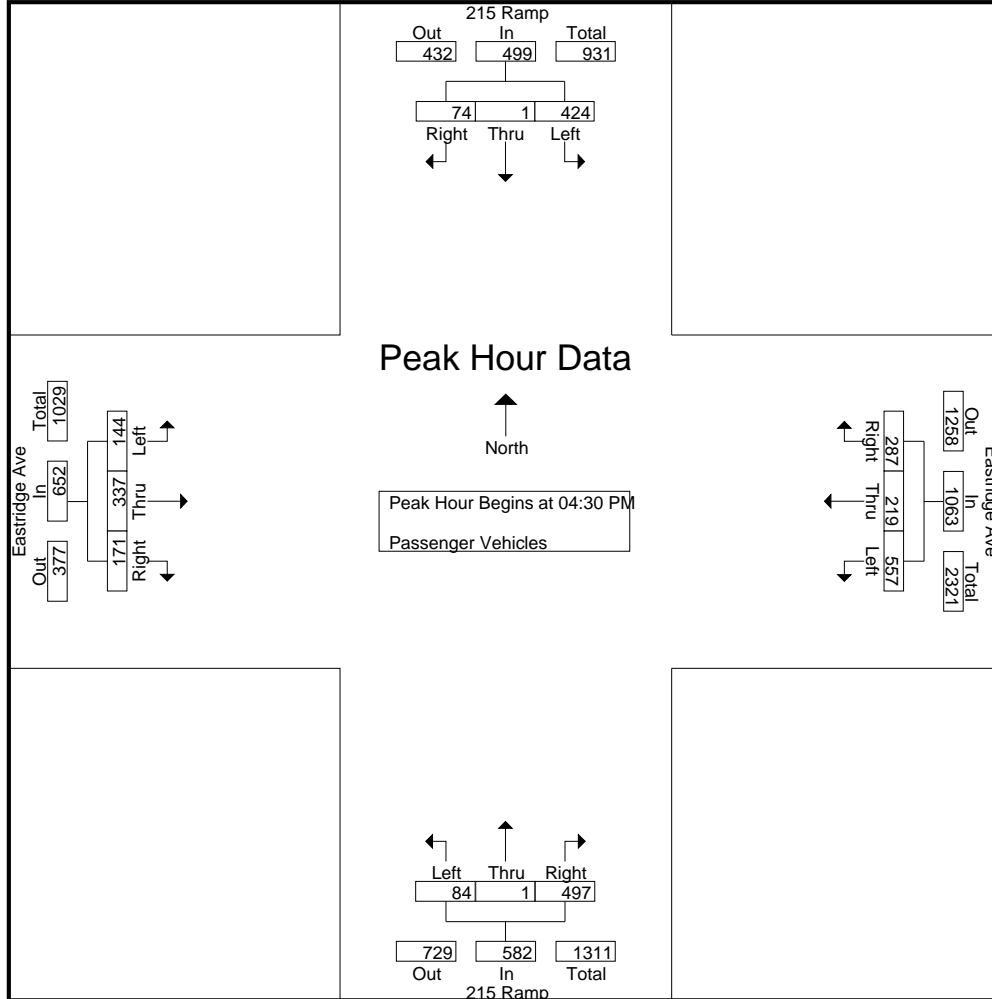

Peak Hour Analysis From 04:30 PM to 05:15 PM - Peak 1 of 1
 Peak Hour for Each Approach Begins at:

	04:30 PM				04:30 PM				04:30 PM				04:30 PM			
+0 mins.	100	0	20	120	164	60	79	303	26	0	112	138	38	84	52	174
+15 mins.	95	0	20	115	121	58	52	231	22	0	141	163	19	74	39	132
+30 mins.	96	0	15	111	145	54	86	285	14	1	106	121	57	112	54	223
+45 mins.	133	1	19	153	127	47	70	244	22	0	138	160	30	67	26	123
Total Volume	424	1	74	499	557	219	287	1063	84	1	497	582	144	337	171	652
% App. Total	85	0.2	14.8		52.4	20.6	27		14.4	0.2	85.4		22.1	51.7	26.2	
PHF	.797	.250	.925	.815	.849	.913	.834	.877	.808	.250	.881	.893	.632	.752	.792	.731

Counts Unlimited Inc
PO Box 1178
Corona, CA 92878
(951) 268-6268

City of Riverside
N/S: I-215 Ramps
E/W: Eastridge Ave
Weather: Clear

File Name : RIV215ERPM
Site Code : 06715392
Start Date : 7/7/2015
Page No : 1

Groups Printed- Large 2 Axle Vehicles

Start Time	215 Ramp Southbound				Eastridge Ave Westbound				215 Ramp Northbound				Eastridge Ave Eastbound				Int. Total
	Left	Thru	Right	App. Total	Left	Thru	Right	App. Total	Left	Thru	Right	App. Total	Left	Thru	Right	App. Total	
04:00 PM	1	0	0	1	3	2	0	5	2	0	1	3	0	1	1	2	11
04:15 PM	0	0	2	2	1	0	1	2	1	0	1	2	0	0	0	0	6
04:30 PM	0	0	0	0	0	0	1	1	0	0	1	1	1	0	1	2	4
04:45 PM	0	0	0	0	1	2	0	3	0	0	5	5	0	0	1	1	9
Total	1	0	2	3	5	4	2	11	3	0	8	11	1	1	3	5	30
05:00 PM	1	0	0	1	1	1	2	4	0	0	1	1	0	0	0	0	6
05:15 PM	2	0	1	3	0	1	0	1	1	0	1	2	1	0	0	1	7
05:30 PM	1	0	0	1	0	0	2	2	2	0	1	3	1	0	0	1	7
05:45 PM	0	0	0	0	1	2	0	3	0	0	0	0	0	0	0	0	3
Total	4	0	1	5	2	4	4	10	3	0	3	6	2	0	0	2	23
Grand Total	5	0	3	8	7	8	6	21	6	0	11	17	3	1	3	7	53
Apprch %	62.5	0	37.5		33.3	38.1	28.6		35.3	0	64.7		42.9	14.3	42.9		
Total %	9.4	0	5.7	15.1	13.2	15.1	11.3	39.6	11.3	0	20.8	32.1	5.7	1.9	5.7	13.2	

Start Time	215 Ramp Southbound				Eastridge Ave Westbound				215 Ramp Northbound				Eastridge Ave Eastbound				Int. Total
	Left	Thru	Right	App. Total	Left	Thru	Right	App. Total	Left	Thru	Right	App. Total	Left	Thru	Right	App. Total	
Peak Hour Analysis From 04:30 PM to 05:15 PM - Peak 1 of 1																	
Peak Hour for Entire Intersection Begins at 04:30 PM																	
04:30 PM	0	0	0	0	0	0	1	1	0	0	1	1	1	0	1	2	4
04:45 PM	0	0	0	0	1	2	0	3	0	0	5	5	0	0	1	1	9
05:00 PM	1	0	0	1	1	1	2	4	0	0	1	1	0	0	0	0	6
05:15 PM	2	0	1	3	0	1	0	1	1	0	1	2	1	0	0	1	7
Total Volume	3	0	1	4	2	4	3	9	1	0	8	9	2	0	2	4	26
% App. Total	75	0	25		22.2	44.4	33.3		11.1	0	88.9		50	0	50		
PHF	.375	.000	.250	.333	.500	.500	.375	.563	.250	.000	.400	.450	.500	.000	.500	.500	.722

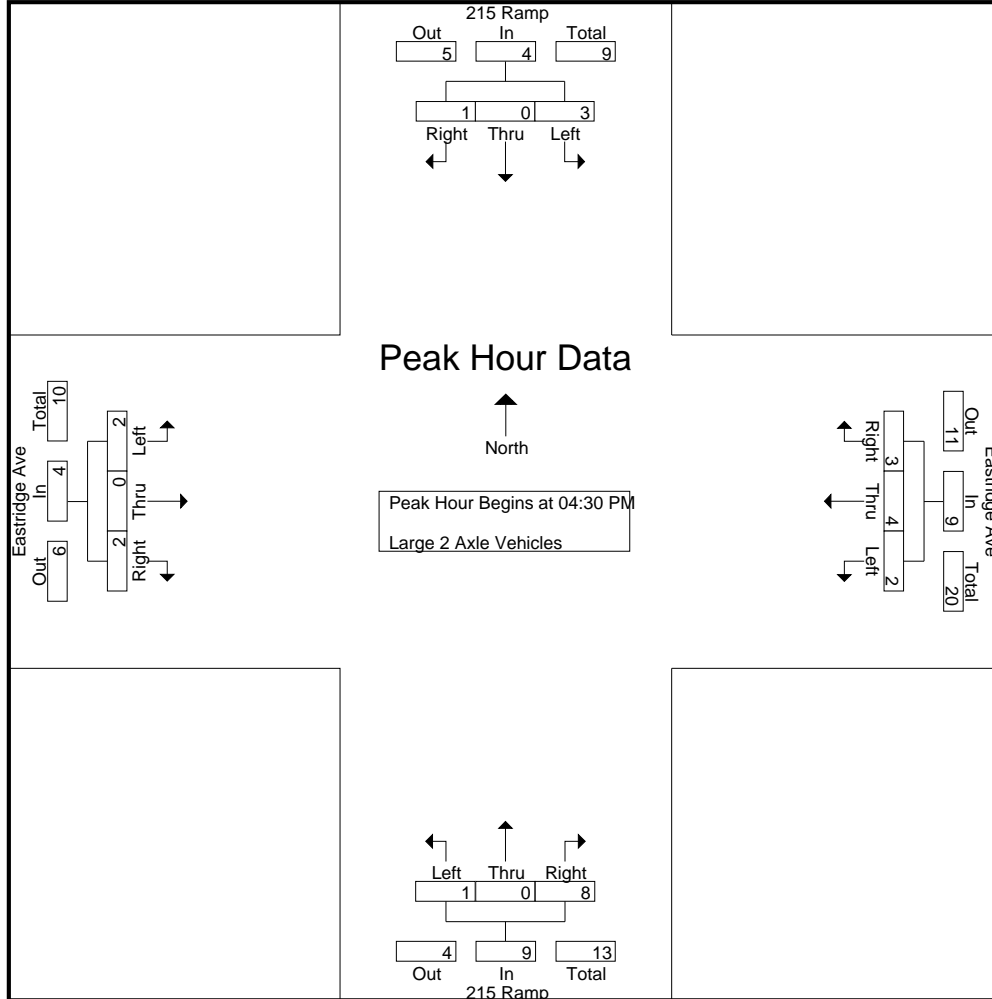

Peak Hour Analysis From 04:30 PM to 05:15 PM - Peak 1 of 1
 Peak Hour for Each Approach Begins at:

	04:30 PM				04:30 PM				04:30 PM				04:30 PM			
+0 mins.	0	0	0	0	0	0	1	1	0	0	1	1	1	0	1	2
+15 mins.	0	0	0	0	1	2	0	3	0	0	5	5	0	0	1	1
+30 mins.	1	0	0	1	1	1	2	4	0	0	1	1	0	0	0	0
+45 mins.	2	0	1	3	0	1	0	1	1	0	1	2	1	0	0	1
Total Volume	3	0	1	4	2	4	3	9	1	0	8	9	2	0	2	4
% App. Total	75	0	25		22.2	44.4	33.3		11.1	0	88.9		50	0	50	
PHF	.375	.000	.250	.333	.500	.500	.375	.563	.250	.000	.400	.450	.500	.000	.500	.500

Counts Unlimited Inc
 PO Box 1178
 Corona, CA 92878
 (951) 268-6268

City of Riverside
 N/S: I-215 Ramps
 E/W: Eastridge Ave
 Weather: Clear

File Name : RIV215ERPM
 Site Code : 06715392
 Start Date : 7/7/2015
 Page No : 1

Groups Printed- 3 Axle Vehicles

Start Time	215 Ramp Southbound				Eastridge Ave Westbound				215 Ramp Northbound				Eastridge Ave Eastbound				Int. Total	
	Left	Thru	Right	App. Total	Left	Thru	Right	App. Total	Left	Thru	Right	App. Total	Left	Thru	Right	App. Total		
04:00 PM	0	0	1	1	0	0	0	0	0	0	0	0	0	0	0	0	0	1
04:15 PM	0	0	0	0	0	0	0	0	0	0	1	1	0	0	0	0	0	1
04:30 PM	0	0	0	0	0	0	0	0	0	0	0	0	0	0	0	0	0	0
04:45 PM	0	0	1	1	0	0	0	0	0	0	0	0	0	0	1	1	1	2
Total	0	0	2	2	0	0	0	0	0	0	1	1	0	0	1	1	1	4
05:00 PM	0	0	1	1	0	0	0	0	0	0	0	0	0	0	0	0	0	1
05:15 PM	0	0	0	0	0	0	0	0	0	0	0	0	0	0	0	0	0	0
05:30 PM	0	0	0	0	0	1	0	1	0	0	0	0	0	0	1	1	1	2
05:45 PM	0	0	0	0	0	0	0	0	0	0	0	0	0	0	0	0	0	0
Total	0	0	1	1	0	1	0	1	0	0	0	0	0	0	1	1	1	3
Grand Total	0	0	3	3	0	1	0	1	0	0	1	1	0	0	2	2	2	7
Apprch %	0	0	100		0	100	0		0	0	100		0	0	100			
Total %	0	0	42.9	42.9	0	14.3	0	14.3	0	0	14.3	14.3	0	0	28.6	28.6		

Start Time	215 Ramp Southbound				Eastridge Ave Westbound				215 Ramp Northbound				Eastridge Ave Eastbound				Int. Total	
	Left	Thru	Right	App. Total	Left	Thru	Right	App. Total	Left	Thru	Right	App. Total	Left	Thru	Right	App. Total		
Peak Hour Analysis From 04:30 PM to 05:15 PM - Peak 1 of 1																		
Peak Hour for Entire Intersection Begins at 04:30 PM																		
04:30 PM	0	0	0	0	0	0	0	0	0	0	0	0	0	0	0	0	0	0
04:45 PM	0	0	1	1	0	0	0	0	0	0	0	0	0	0	1	1	1	2
05:00 PM	0	0	1	1	0	0	0	0	0	0	0	0	0	0	0	0	0	1
05:15 PM	0	0	0	0	0	0	0	0	0	0	0	0	0	0	0	0	0	0
Total Volume	0	0	2	2	0	0	0	0	0	0	0	0	0	0	1	1	1	3
% App. Total	0	0	100		0	0	0		0	0	0		0	0	100			
PHF	.000	.000	.500	.500	.000	.000	.000	.000	.000	.000	.000	.000	.000	.000	.250	.250	.375	

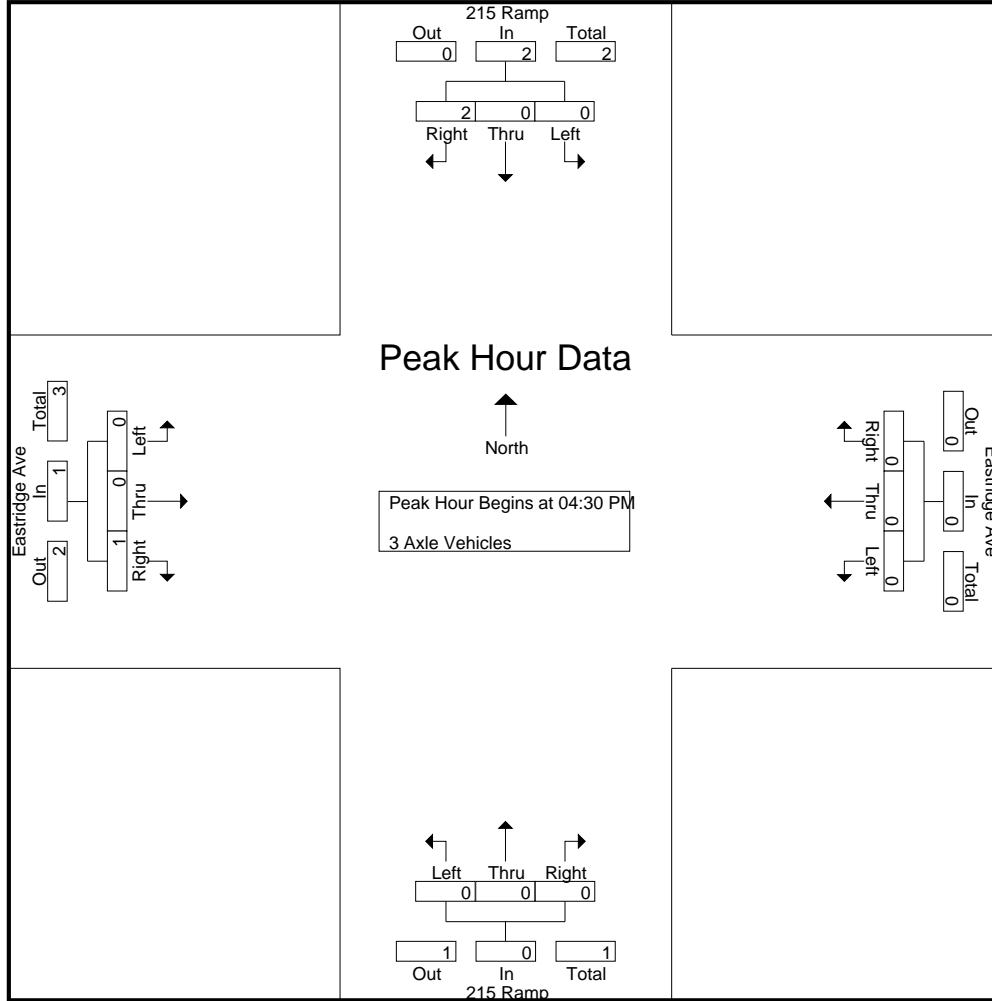

Peak Hour Analysis From 04:30 PM to 05:15 PM - Peak 1 of 1
 Peak Hour for Each Approach Begins at:

	04:30 PM				04:30 PM				04:30 PM				04:30 PM			
+0 mins.	0	0	0	0	0	0	0	0	0	0	0	0	0	0	0	0
+15 mins.	0	0	1	1	0	0	0	0	0	0	0	0	0	0	1	1
+30 mins.	0	0	1	1	0	0	0	0	0	0	0	0	0	0	0	0
+45 mins.	0	0	0	0	0	0	0	0	0	0	0	0	0	0	0	0
Total Volume	0	0	2	2	0	0	0	0	0	0	0	0	0	0	1	1
% App. Total	0	0	100		0	0	0		0	0	0		0	0	100	
PHF	.000	.000	.500	.500	.000	.000	.000	.000	.000	.000	.000	.000	.000	.000	.250	.250

Counts Unlimited Inc
PO Box 1178
Corona, CA 92878
(951) 268-6268

City of Riverside
N/S: I-215 Ramps
E/W: Eastridge Ave
Weather: Clear

File Name : RIV215ERPM
Site Code : 06715392
Start Date : 7/7/2015
Page No : 1

Groups Printed- 4+ Axle Trucks

Start Time	215 Ramp Southbound				Eastridge Ave Westbound				215 Ramp Northbound				Eastridge Ave Eastbound				Int. Total
	Left	Thru	Right	App. Total	Left	Thru	Right	App. Total	Left	Thru	Right	App. Total	Left	Thru	Right	App. Total	
04:00 PM	0	0	5	5	0	0	0	0	1	0	1	2	5	0	3	8	15
04:15 PM	0	0	5	5	0	0	0	0	0	0	0	0	8	1	3	12	17
04:30 PM	0	0	6	6	0	0	0	0	2	0	0	2	10	0	3	13	21
04:45 PM	0	0	7	7	0	1	2	3	3	0	0	3	7	0	0	7	20
Total	0	0	23	23	0	1	2	3	6	0	1	7	30	1	9	40	73
05:00 PM	0	0	4	4	0	0	0	0	2	0	0	2	4	1	4	9	15
05:15 PM	0	0	4	4	0	0	0	0	2	0	0	2	4	0	1	5	11
05:30 PM	2	0	7	9	0	0	0	0	1	0	0	1	8	0	1	9	19
05:45 PM	0	0	6	6	0	1	0	1	1	0	0	1	2	0	2	4	12
Total	2	0	21	23	0	1	0	1	6	0	0	6	18	1	8	27	57
Grand Total	2	0	44	46	0	2	2	4	12	0	1	13	48	2	17	67	130
Apprch %	4.3	0	95.7		0	50	50		92.3	0	7.7		71.6	3	25.4		
Total %	1.5	0	33.8	35.4	0	1.5	1.5	3.1	9.2	0	0.8	10	36.9	1.5	13.1	51.5	

Start Time	215 Ramp Southbound				Eastridge Ave Westbound				215 Ramp Northbound				Eastridge Ave Eastbound				Int. Total
	Left	Thru	Right	App. Total	Left	Thru	Right	App. Total	Left	Thru	Right	App. Total	Left	Thru	Right	App. Total	
Peak Hour Analysis From 04:30 PM to 05:15 PM - Peak 1 of 1																	
Peak Hour for Entire Intersection Begins at 04:30 PM																	
04:30 PM	0	0	6	6	0	0	0	0	2	0	0	2	10	0	3	13	21
04:45 PM	0	0	7	7	0	1	2	3	3	0	0	3	7	0	0	7	20
05:00 PM	0	0	4	4	0	0	0	0	2	0	0	2	4	1	4	9	15
05:15 PM	0	0	4	4	0	0	0	0	2	0	0	2	4	0	1	5	11
Total Volume	0	0	21	21	0	1	2	3	9	0	0	9	25	1	8	34	67
% App. Total	0	0	100		0	33.3	66.7		100	0	0		73.5	2.9	23.5		
PHF	.000	.000	.750	.750	.000	.250	.250	.250	.750	.000	.000	.750	.625	.250	.500	.654	.798

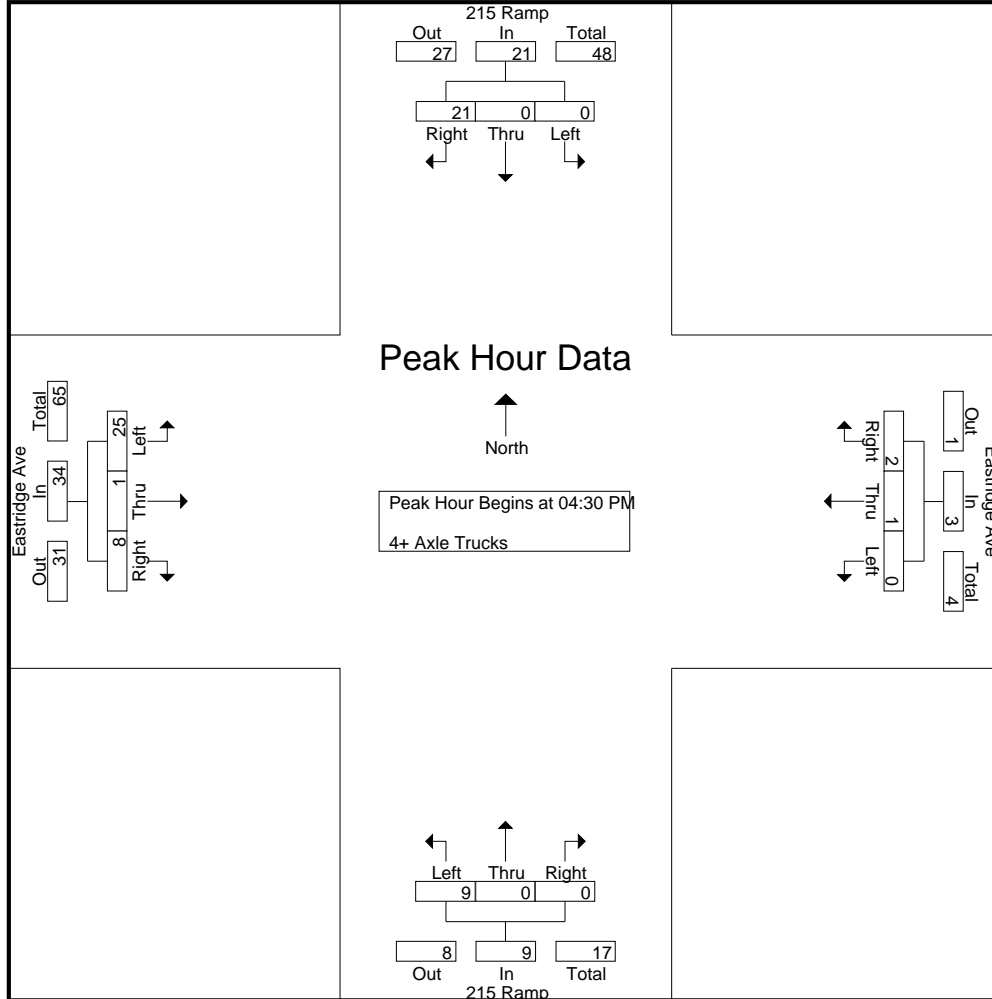

Peak Hour Analysis From 04:30 PM to 05:15 PM - Peak 1 of 1
 Peak Hour for Each Approach Begins at:

	04:30 PM				04:30 PM				04:30 PM				04:30 PM			
+0 mins.	0	0	6	6	0	0	0	0	2	0	0	2	10	0	3	13
+15 mins.	0	0	7	7	0	1	2	3	3	0	0	3	7	0	0	7
+30 mins.	0	0	4	4	0	0	0	0	2	0	0	2	4	1	4	9
+45 mins.	0	0	4	4	0	0	0	0	2	0	0	2	4	0	1	5
Total Volume	0	0	21	21	0	1	2	3	9	0	0	9	25	1	8	34
% App. Total	0	0	100		0	33.3	66.7		100	0	0		73.5	2.9	23.5	
PHF	.000	.000	.750	.750	.000	.250	.250	.250	.750	.000	.000	.750	.625	.250	.500	.654

Location: SR-60 East to I-215 South Truck Bypass Ramp
Start Date: 8/6/2015
Start Time: 12:00 AM
City of: Riverside
Weather: Clear

Entering

	Passenger Vehicles	Large 2 Axle Vehicles	3 Axle Vehicles	4= Axle Vehicles	TOTAL
12:00 AM	33	0	1	34	68
12:15 AM	49	2	3	31	85
12:30 AM	44	2	0	34	80
12:45 AM	35	0	1	31	67
1:00 AM	23	1	0	30	54
1:15 AM	29	2	0	32	63
1:30 AM	27	2	0	37	66
1:45 AM	22	6	0	30	58
2:00 AM	19	4	0	31	54
2:15 AM	20	4	3	24	51
2:30 AM	16	5	2	26	49
2:45 AM	24	13	1	26	64
3:00 AM	13	6	3	40	62
3:15 AM	22	13	2	55	92
3:30 AM	12	12	5	43	72
3:45 AM	25	11	0	43	79
4:00 AM	23	13	0	35	71
4:15 AM	35	12	0	42	89
4:30 AM	33	9	0	49	91
4:45 AM	42	11	1	72	126
5:00 AM	40	17	0	47	104
5:15 AM	45	23	2	58	128
5:30 AM	73	25	4	52	154
5:45 AM	76	35	8	59	178
6:00 AM	65	40	20	62	187
6:15 AM	62	29	19	81	191
6:30 AM	92	20	26	62	200
6:45 AM	99	30	19	69	217
7:00 AM	76	36	13	52	177
7:15 AM	90	30	18	64	202
7:30 AM	97	30	27	51	205
7:45 AM	87	41	9	48	185
8:00 AM	90	45	17	75	227
8:15 AM	70	23	12	85	190
8:30 AM	84	39	21	85	229
8:45 AM	85	42	11	59	197

Location: SR-60 East to I-215 South Truck Bypass Ramp
Start Date: 8/6/2015
Start Time: 12:00 AM
City of: Riverside
Weather: Clear

Entering

	Passenger Vehicles	Large 2 Axle Vehicles	3 Axle Vehicles	4= Axle Vehicles	TOTAL
9:00 AM	82	35	20	73	210
9:15 AM	82	26	18	68	194
9:30 AM	97	19	20	82	218
9:45 AM	132	27	16	96	271
10:00 AM	98	28	28	86	240
10:15 AM	96	36	24	99	255
10:30 AM	104	37	20	61	222
10:45 AM	114	26	30	70	240
11:00 AM	102	21	20	89	232
11:15 AM	145	39	21	73	278
11:30 AM	122	38	30	76	266
11:45 AM	116	32	30	90	268

Location: SR-60 East to I-215 South Truck Bypass Ramp
Start Date: 8/6/2015
Start Time: 12:00 AM
City of: Riverside
Weather: Clear

Entering

	Passenger Vehicles	Large 2 Axle Vehicles	3 Axle Vehicles	4= Axle Vehicles	TOTAL
12:00 PM	103	24	21	78	226
12:15 PM	135	31	23	77	266
12:30 PM	135	23	30	66	254
12:45 PM	147	32	12	77	268
1:00 PM	125	26	12	68	231
1:15 PM	148	30	13	76	267
1:30 PM	144	22	19	81	266
1:45 PM	142	33	10	77	262
2:00 PM	142	31	13	54	240
2:15 PM	152	22	17	77	268
2:30 PM	160	20	17	54	251
2:45 PM	145	23	14	47	229
3:00 PM	161	27	16	54	258
3:15 PM	163	26	15	44	248
3:30 PM	198	27	20	45	290
3:45 PM	204	13	14	42	273
4:00 PM	174	17	9	44	244
4:15 PM	169	8	13	28	218
4:30 PM	172	6	10	38	226
4:45 PM	217	19	6	32	274
5:00 PM	210	18	6	32	266
5:15 PM	214	12	6	33	265
5:30 PM	219	18	7	42	286
5:45 PM	199	8	11	34	252
6:00 PM	198	17	12	42	269
6:15 PM	203	9	7	38	257
6:30 PM	175	5	8	52	240
6:45 PM	169	15	14	52	250
7:00 PM	166	15	13	48	242
7:15 PM	164	11	9	38	222
7:30 PM	157	7	10	38	212
7:45 PM	144	12	11	34	201
8:00 PM	145	4	8	39	196
8:15 PM	118	10	1	43	172
8:30 PM	117	13	7	48	185
8:45 PM	127	0	4	36	167

Location: SR-60 East to I-215 South Truck Bypass Ramp
Start Date: 8/6/2015
Start Time: 12:00 AM
City of: Riverside
Weather: Clear

Entering

	Passenger Vehicles	Large 2 Axle Vehicles	3 Axle Vehicles	4= Axle Vehicles	TOTAL
9:00 PM	143	10	5	40	198
9:15 PM	129	3	8	41	181
9:30 PM	108	3	5	31	147
9:45 PM	87	2	2	39	130
10:00 PM	93	4	3	36	136
10:15 PM	94	3	2	24	123
10:30 PM	81	3	3	32	119
10:45 PM	64	0	2	28	94
11:00 PM	75	1	2	33	111
11:15 PM	75	0	1	25	101
11:30 PM	57	1	5	26	89
11:45 PM	44	0	1	41	86
TOTAL	9978	1661	1002	4921	17562

Passenger Car Equivalent (PCE) Worksheets

1. I-215 NB Ramps / Fair Isle Dr-Box Springs Rd

Count Date: 7/7/2015
 Peak Hour: 7:00-8:00 AM
 PHF: 0.872

				I-215 NB Ramps									
				In	Out	Total							
4+ Axle Trucks				0	0	0	0	47	47				
3 Axle Trucks				0	0	0	0	3	3				
2 Axle Trucks				0	0	0	0	26	26				
Passenger Cars				0	0	0	0	1273	1273				
Total in PCE				0	0	0	0	1460	1460				













Fair Isle Dr-Box Springs Rd	In	Out	Total	I-215 NB Ramps					
				Total in PCE	Passenger Cars	2 Axle Trucks	3 Axle Trucks	4+ Axle Trucks	
47	44	44	47	898	872	11	0	3	
3	3	3	3	446	426	7	0	3	
0	0	0	0	0	0	0	0	0	
28	18	15	28	1344	1298	18	0	6	
1020	513	386	1020	134	129	3	0	0	
1211	679	547	1211	1478	1427	21	0	6	
Total	In	Out	Total	Total	Total	Total	Total	Total	

Fair Isle Dr-Box Springs Rd	In	Out	Total	I-215 NB Ramps					
				Total in PCE	Passenger Cars	2 Axle Trucks	3 Axle Trucks	4+ Axle Trucks	
44	0	0	44	86	15	2			
3	0	0	3	81	15	2			
0	0	0	0	3	0	0			
15	0	0	15	0	0	0			
386	0	0	386	0	0	0			
547	0	0	547	0	0	0			
Total	Total	Total	Total	Total	Total	Total			

PCE Factors
 Passenger Cars = 1 PCE
 2 Axle Trucks = 1.5 PCE
 3 Axle Trucks = 2 PCE
 4+ Axle Trucks = 3 PCE

1. I-215 NB Ramps / Fair Isle Dr-Box Springs Rd

Count Date: 7/7/2015
 Peak Hour: 5:00-6:00 PM
 PHF: 0.965

					I-215 NB Ramps												
		In	Out	Total				Total in PCE	Passenger Cars	2 Axle Trucks	3 Axle Trucks	4+ Axle Trucks					
	4+ Axle Trucks	0	0	0	0	15	15										
	3 Axle Trucks	0	0	0	0	4	4										
	2 Axle Trucks	0	0	0	0	13	13										
	Passenger Cars	0	0	0	0	648	648										
	Total in PCE	0	0	0	0	721	721										
					In	Out	Total										
Fair Isle Dr-Box Springs Rd		15	0	15					284	279	3	0	0				
		0	0	0					171	162	6	0	0				
		15	4	19					0	0	0	0	0				
		0	4	4				In	455	441	9	0	0				
		0	11	11				Out	662	645	11	0	0				
		0	10	10				Total	1117	1086	20	0	0				
		15	8	23													
	4+ Axle Trucks	15	0	15													
	3 Axle Trucks	0	0	0													
	2 Axle Trucks	0	8	8													
	Passenger Cars	0	642	642													
	Total in PCE	0	659	659													
					In	Out	Total										
		83	6	89													
	Total in PCE	83	6	89													
	Passenger Cars	80	6	86													
	2 Axle Trucks	2	0	2													
	3 Axle Trucks	0	0	0													
	4+ Axle Trucks	0	0	0													
					In	Out	Total										
		83	6	89													
	Total in PCE	83	6	89													
	Passenger Cars	80	6	86													
	2 Axle Trucks	2	0	2													
	3 Axle Trucks	0	0	0													
	4+ Axle Trucks	0	0	0													

PCE Factors

Passenger Cars = 1 PCE
 2 Axle Trucks = 1.5 PCE
 3 Axle Trucks = 2 PCE
 4+ Axle Trucks = 3 PCE

2. Sycamore Canyon Boulevard / Fair Isle Road

Count Date: 7/7/2015
 Peak Hour: 7:00-8:00 AM
 PHF: 0.948

		Sycamore Canyon Boulevard																			
		4+ Axle Trucks	0	1	0	1	13	14													
		3 Axle Trucks	1	2	0	3	2	5													
		2 Axle Trucks	0	8	0	8	30	38													
		Passenger Cars	13	108	42	163	1545	1708													
		Total in PCE	15	127	42	184	1633	1817													
			↙	↓	↘	In	Out	Total													
											↙	Total in PCE	358	Passenger Cars	340	2 Axle Trucks	6	3 Axle Trucks	0	4+ Axle Trucks	3
											←	62	62	0	0	0	0	0	0	0	0
											↙	117	108	6	0	0	0	0	0	0	0
											In	537	510	12	0	0	3				
											Out	697	538	17	2	43					
											Total	1234	1048	29	2	46					
											↙ ↕ ↘										
		Total	2265	351	1914	112	1239	563							Total in PCE						
		4+ Axle Trucks	61	20	41	4	22	15							Passenger Cars						
		3 Axle Trucks	7	3	4	0	2	2							2 Axle Trucks						
		2 Axle Trucks	54	1	53	0	10	43							3 Axle Trucks						
		Passenger Cars													4+ Axle Trucks						
		Total in PCE																			
		Sycamore Canyon Boulevard																			

PCE Factors

- Passenger Cars = 1 PCE
- 2 Axle Trucks = 1.5 PCE
- 3 Axle Trucks = 2 PCE
- 4+ Axle Trucks = 3 PCE

2. Sycamore Canyon Boulevard / Fair Isle Road

Count Date: 7/7/2015
 Peak Hour: 4:30-5:30 PM
 PHF: 0.933

		Sycamore Canyon Boulevard												
		In	Out	Total										
Fair Isle Road	4+ Axle Trucks	0	0	0	0	0	0	Fair Isle Road	Total in PCE	71	68	2	0	0
	3 Axle Trucks	0	1	0	1	0	1		Passenger Cars	80	77	2	0	0
	2 Axle Trucks	0	6	4	10	7	17		2 Axle Trucks	104	92	8	0	0
	Passenger Cars	35	330	317	682	286	968		3 Axle Trucks	255	237	12	0	0
	Total in PCE	35	341	323	699	297	996		4+ Axle Trucks	1057	931	41	2	20
		Sycamore Canyon Boulevard												
		Total	Out	In										
		1607	540	1067	214	204	649	Total in PCE	1312	1168	53	2	20	
		1461	517	944	205	201	538	Passenger Cars	1057	931	41	2	20	
		53	14	39	6	2	31	2 Axle Trucks	104	92	8	0	0	
		3	1	2	0	0	2	3 Axle Trucks	255	237	12	0	0	
		20	0	20	0	0	20	4+ Axle Trucks	1057	931	41	2	20	
		Sycamore Canyon Boulevard												

PCE Factors

- Passenger Cars = 1 PCE
- 2 Axle Trucks = 1.5 PCE
- 3 Axle Trucks = 2 PCE
- 4+ Axle Trucks = 3 PCE

3. Sycamore Canyon Boulevard / I-215 Southbound Ramps

Count Date: 7/7/2015
 Peak Hour: 4:30-5:30 PM
 PHF: 0.925

		Sycamore Canyon Boulevard												
		4+ Axle Trucks	0	0	0	0	20	20						
		3 Axle Trucks	0	0	0	0	2	2						
		2 Axle Trucks	0	7	3	10	17	27						
		Passenger Cars	0	369	153	522	923	1445						
		Total in PCE	0	380	158	538	1013	1551						
			↙	↓	↘	In	Out	Total	Total in PCE	Passenger Cars	2 Axle Trucks	3 Axle Trucks	4+ Axle Trucks	
I-215 Southbound Ramps	Total	0	0	0	0	0	0	0	↙	236	227	6	0	0
	Out	0	0	0	0	0	0	0	←	0	0	0	0	0
	In	0	0	0	0	0	0	0	↙	151	99	4	8	10
		0	0	0	0	0	0	0	↘	387	326	10	8	10
		0	0	0	0	0	0	0	↘	304	291	4	0	2
	4+ Axle Trucks	0	0	0	0	0	0	0	Total	691	617	14	8	12
	3 Axle Trucks	0	0	0	0	0	0	0	In	387	326	10	8	10
	2 Axle Trucks	0	0	0	0	0	0	0	Out	304	291	4	0	2
	Passenger Cars	0	0	0	0	0	0	0	Total in PCE	691	617	14	8	12
	Total in PCE	0	0	0	0	0	0	0	Passenger Cars	387	326	10	8	10
		Total	1454	531	923	0	777	146	2 Axle Trucks	387	326	10	8	10
			1302	468	834	0	696	138	3 Axle Trucks	304	291	4	0	2
			23	11	12	0	11	1	4+ Axle Trucks	0	0	0	0	0
			10	8	2	0	2	0		0	0	0	0	0
			32	10	22	0	20	2		0	0	0	0	0
			Sycamore Canyon Boulevard											

PCE Factors

- Passenger Cars = 1 PCE
- 2 Axle Trucks = 1.5 PCE
- 3 Axle Trucks = 2 PCE
- 4+ Axle Trucks = 3 PCE

4. Sycamore Canyon Boulevard / Dan Kipper Drive

Count Date: 7/7/2015
 Peak Hour: 4:30-5:30 PM
 PHF: 0.834

		Sycamore Canyon Boulevard												
		4+ Axle Trucks	0	8	0	8	21	29						
		3 Axle Trucks	0	8	0	8	2	10						
		2 Axle Trucks	1	4	0	5	12	17						
		Passenger Cars	1	440	0	441	814	1255						
		Total in PCE	3	486	0	489	899	1388	Total in PCE	Passenger Cars	2 Axle Trucks	3 Axle Trucks	4+ Axle Trucks	
			↙	↓	↘	In	Out	Total						
Dan Kipper Drive		0	0	0	0	0	0	0	↙	0	0	0	0	0
		0	0	0	1	2	4	0	←	0	0	0	0	0
		0	0	0	0	1	1	0	↙	0	0	0	0	0
		0	0	0	0	0	0	0	↘	0	0	0	0	0
		0	0	0	0	0	0	0	In	0	0	0	0	0
	0	0	0	0	0	0	0	Out	0	0	0	0	0	
	0	0	0	1	1	0	0	Total	0	0	0	0	0	
	4+ Axle Trucks	0	0	0	0	0	0	↙						
	3 Axle Trucks	0	0	0	0	0	0	→						
	2 Axle Trucks	0	0	0	0	0	0	↘						
	Passenger Cars	1	0	0	0	0	0							
	Total in PCE	1	0	0	0	0	0							
		Total	1387	487	900	1	899	0	Total in PCE					
			1256	441	815	1	814	0	Passenger Cars					
			16	4	12	0	12	0	2 Axle Trucks					
			10	8	2	0	2	0	3 Axle Trucks					
			29	8	21	0	21	0	4+ Axle Trucks					
			Sycamore Canyon Boulevard											

PCE Factors

- Passenger Cars = 1 PCE
- 2 Axle Trucks = 1.5 PCE
- 3 Axle Trucks = 2 PCE
- 4+ Axle Trucks = 3 PCE

5. Sycamore Canyon Boulevard / Box Springs Boulevard

Count Date: 7/7/2015
 Peak Hour: 7:00-8:00 AM
 PHF: 0.903

		Sycamore Canyon Boulevard												
		↙	↓	↘	In	Out	Total	Total in PCE	Passenger Cars	2 Axle Trucks	3 Axle Trucks	4+ Axle Trucks		
4+ Axle Trucks		0	6	1	7	45	52							
3 Axle Trucks		0	2	2	4	10	14							
2 Axle Trucks		0	8	1	9	19	28							
Passenger Cars		0	327	133	460	1575	2035							
Total in PCE		0	361	142	503	1759	2262							
Box Springs Boulevard														
↙	0	0	0	0	0	0	0	↙	245	231	1	3	2	
↘	0	0	0	0	0	0	0	↘	0	0	0	0	0	
↙	0	0	0	0	0	0	0	↙	20	9	2	1	2	
↘	0	0	0	0	0	0	0	↘	265	240	3	4	4	
↙	0	0	0	0	0	0	0	↙	176	145	2	3	7	
↘	0	0	0	0	0	0	0	↘	385	385	5	7	11	
Total														
4+ Axle Trucks		1929	381	1548	0	1514	34	Total in PCE						
3 Axle Trucks		1692	336	1356	0	1344	12	Passenger Cars						
2 Axle Trucks		29	10	19	0	18	1	2 Axle Trucks						
Passenger Cars		11	3	8	0	7	1	3 Axle Trucks						
Total in PCE		57	8	49	0	43	6	4+ Axle Trucks						
		Sycamore Canyon Boulevard												

PCE Factors

- Passenger Cars = 1 PCE
- 2 Axle Trucks = 1.5 PCE
- 3 Axle Trucks = 2 PCE
- 4+ Axle Trucks = 3 PCE













5. Sycamore Canyon Boulevard / Box Springs Boulevard

Count Date: 7/7/2015
 Peak Hour: 4:30-5:30 PM
 PHF: 0.845

		Sycamore Canyon Boulevard											
		↙	↓	↘	In	Out	Total	↙	←	↘	In	Out	Total
4+ Axle Trucks	0	10	1	11	19	30	Total in PCE	247	0	17	264	62	326
3 Axle Trucks	0	2	1	3	5	8	Passenger Cars	228	0	8	236	45	281
2 Axle Trucks	0	8	6	14	10	24	2 Axle Trucks	3	0	0	3	6	9
Passenger Cars	0	391	40	431	781	1212	3 Axle Trucks	1	0	0	1	1	2
Total in PCE	0	437	54	491	864	1355	4+ Axle Trucks	4	0	3	7	2	9
↙	0	0	0	0	0	0	↙	17	0	0	17	0	17
↘	0	0	0	0	0	0	↘	8	0	0	8	0	8
↙	0	0	0	0	0	0	↙	0	0	0	0	0	0
↘	0	0	0	0	0	0	↘	0	0	0	0	0	0
↙	0	0	0	0	0	0	↙	0	0	0	0	0	0
↘	0	0	0	0	0	0	↘	0	0	0	0	0	0
↙	0	0	0	0	0	0	↙	0	0	0	0	0	0
↘	0	0	0	0	0	0	↘	0	0	0	0	0	0
↙	0	0	0	0	0	0	↙	0	0	0	0	0	0
↘	0	0	0	0	0	0	↘	0	0	0	0	0	0
↙	0	0	0	0	0	0	↙	0	0	0	0	0	0
↘	0	0	0	0	0	0	↘	0	0	0	0	0	0
↙	0	0	0	0	0	0	↙	0	0	0	0	0	0
↘	0	0	0	0	0	0	↘	0	0	0	0	0	0
↙	0	0	0	0	0	0	↙	0	0	0	0	0	0
↘	0	0	0	0	0	0	↘	0	0	0	0	0	0
↙	0	0	0	0	0	0	↙	0	0	0	0	0	0
↘	0	0	0	0	0	0	↘	0	0	0	0	0	0
↙	0	0	0	0	0	0	↙	0	0	0	0	0	0
↘	0	0	0	0	0	0	↘	0	0	0	0	0	0
↙	0	0	0	0	0	0	↙	0	0	0	0	0	0
↘	0	0	0	0	0	0	↘	0	0	0	0	0	0
↙	0	0	0	0	0	0	↙	0	0	0	0	0	0
↘	0	0	0	0	0	0	↘	0	0	0	0	0	0
↙	0	0	0	0	0	0	↙	0	0	0	0	0	0
↘	0	0	0	0	0	0	↘	0	0	0	0	0	0
↙	0	0	0	0	0	0	↙	0	0	0	0	0	0
↘	0	0	0	0	0	0	↘	0	0	0	0	0	0
↙	0	0	0	0	0	0	↙	0	0	0	0	0	0
↘	0	0	0	0	0	0	↘	0	0	0	0	0	0
↙	0	0	0	0	0	0	↙	0	0	0	0	0	0
↘	0	0	0	0	0	0	↘	0	0	0	0	0	0
↙	0	0	0	0	0	0	↙	0	0	0	0	0	0
↘	0	0	0	0	0	0	↘	0	0	0	0	0	0
↙	0	0	0	0	0	0	↙	0	0	0	0	0	0
↘	0	0	0	0	0	0	↘	0	0	0	0	0	0
↙	0	0	0	0	0	0	↙	0	0	0	0	0	0
↘	0	0	0	0	0	0	↘	0	0	0	0	0	0
↙	0	0	0	0	0	0	↙	0	0	0	0	0	0
↘	0	0	0	0	0	0	↘	0	0	0	0	0	0
↙	0	0	0	0	0	0	↙	0	0	0	0	0	0
↘	0	0	0	0	0	0	↘	0	0	0	0	0	0
↙	0	0	0	0	0	0	↙	0	0	0	0	0	0
↘	0	0	0	0	0	0	↘	0	0	0	0	0	0
↙	0	0	0	0	0	0	↙	0	0	0	0	0	0
↘	0	0	0	0	0	0	↘	0	0	0	0	0	0
↙	0	0	0	0	0	0	↙	0	0	0	0	0	0
↘	0	0	0	0	0	0	↘	0	0	0	0	0	0
↙	0	0	0	0	0	0	↙	0	0	0	0	0	0
↘	0	0	0	0	0	0	↘	0	0	0	0	0	0
↙	0	0	0	0	0	0	↙	0	0	0	0	0	0
↘	0	0	0	0	0	0	↘	0	0	0	0	0	0
↙	0	0	0	0	0	0	↙	0	0	0	0	0	0
↘	0	0	0	0	0	0	↘	0	0	0	0	0	0
↙	0	0	0	0	0	0	↙	0	0	0	0	0	0
↘	0	0	0	0	0	0	↘	0	0	0	0	0	0
↙	0	0	0	0	0	0	↙	0	0	0	0	0	0
↘	0	0	0										

6. Sycamore Canyon Boulevard / Sierra Ridge Drive

Count Date: 7/7/2015
 Peak Hour: 7:00-8:00 AM
 PHF: 0.880

		Sycamore Canyon Boulevard												
	4+ Axle Trucks	11	12	0	23	61	84							
	3 Axle Trucks	0	4	0	4	9	13							
	2 Axle Trucks	3	7	0	10	37	47							
	Passenger Cars	32	277	0	309	1377	1686							
	Total in PCE	70	332	0	402	1634	2036							
					In	Out	Total							
		Total in PCE	Passenger Cars	2 Axle Trucks	3 Axle Trucks	4+ Axle Trucks								
Sierra Ridge Drive		0	0	0	0	0								
		0	0	0	0	0								
		0	0	0	0	0								
		0	0	0	0	0	In	0	0	0	0	0		
		0	0	0	0	0	Out	0	0	0	0	0		
		0	0	0	0	0	Total	0	0	0	0	0		
		In	Out	Total										
	7	0	9	30										
	0	0	0	0										
	2	2	15	24										
		Total	Out	In										
	4+ Axle Trucks	2111	356	1755	151	1604	0	Total in PCE						
	3 Axle Trucks	1793	292	1501	133	1368	0	Passenger Cars						
	2 Axle Trucks	54	9	45	8	37	0	2 Axle Trucks						
	Passenger Cars	13	4	9	0	9	0	3 Axle Trucks						
	Total in PCE	70	14	56	2	54	0	4+ Axle Trucks						
		Sycamore Canyon Boulevard												

PCE Factors

- Passenger Cars = 1 PCE
- 2 Axle Trucks = 1.5 PCE
- 3 Axle Trucks = 2 PCE
- 4+ Axle Trucks = 3 PCE

6. Sycamore Canyon Boulevard / Sierra Ridge Drive

Count Date: 7/7/2015
 Peak Hour: 4:30-5:30 PM
 PHF: 0.904

		Sycamore Canyon Boulevard												
		4+ Axle Trucks	2	10	0	12	25	37						
		3 Axle Trucks	0	1	0	1	0	1						
		2 Axle Trucks	0	6	0	6	9	15						
		Passenger Cars	23	420	0	443	513	956						
		Total in PCE	29	461	0	490	602	1092						
			↙	↓	↘	In	Out	Total	Total in PCE	Passenger Cars	2 Axle Trucks	3 Axle Trucks	4+ Axle Trucks	
Sierra Ridge Drive		9	4	5	3	0	0	0	↙	0	0	0	0	0
		0	0	0	0	0	0	0	←	0	0	0	0	0
		241	93	148	61	0	0	0	↙	0	0	0	0	0
		273	107	166	70	0	0	0	In	0	0	0	0	0
		Total	Out	In	↘	→	↘	Out	Total	0	0	0	0	0
		4+ Axle Trucks	1167	557	610	78	532	0	Total in PCE					
		3 Axle Trucks	1029	507	522	70	452	0	Passenger Cars					
		2 Axle Trucks	18	8	10	1	9	0	2 Axle Trucks					
		Passenger Cars	1	1	0	0	0	0	3 Axle Trucks					
		Total in PCE	36	12	24	2	22	0	4+ Axle Trucks					
			Sycamore Canyon Boulevard											
						↙	↑	↘						

PCE Factors

- Passenger Cars = 1 PCE
- 2 Axle Trucks = 1.5 PCE
- 3 Axle Trucks = 2 PCE
- 4+ Axle Trucks = 3 PCE

7. Sycamore Canyon Boulevard / Eastridge Avenue

Count Date: 7/7/2015
 Peak Hour: 7:00-8:00 AM
 PHF: 0.900

		Sycamore Canyon Boulevard						Eastridge Avenue																																						
		4+ Axle Trucks	3 Axle Trucks	2 Axle Trucks	Passenger Cars	Total in PCE		4+ Axle Trucks	3 Axle Trucks	2 Axle Trucks	Passenger Cars	Total in PCE		In	Out	Total																														
		3	1	0	33	44	2	1	6	106	123	3	0	9	56	184	12	21	4	11	30	136	182	556	96	98	491	3	3	4	10	35	7	7	17	53	25	17	53	25	17					
		8	2	9	202	244	60	5	20	1520	1741	68	7	29	1722	1985	155	135	0	1	6	1125	1010	13	1	31	137	95	3	2	11	137	95	3	2	11	137	95	3	2	11	137	95	3	2	11
		In	Out	Total				In	Out	Total				In	Out	Total				In	Out	Total				In	Out	Total																		

PCE Factors
 Passenger Cars = 1 PCE
 2 Axle Trucks = 1.5 PCE
 3 Axle Trucks = 2 PCE
 4+ Axle Trucks = 3 PCE

8. Box Springs Boulevard / Eastridge Avenue

Count Date: 7/7/2015
 Peak Hour: 4:30-5:30 PM
 PHF: 0.886









		Box Springs Boulevard												
		In	Out	Total	In	Out	Total							
Eastridge Avenue		4+ Axle Trucks	0	1	1	2	8	10	Eastridge Avenue					
		3 Axle Trucks	0	1	0	1	0	1						
		2 Axle Trucks	0	0	2	2	3	5						
		Passenger Cars	15	1	169	185	56	241						
		Total in PCE	15	6	175	196	85	281						
					In	Out	Total	Total in PCE	Passenger Cars	2 Axle Trucks	3 Axle Trucks	4+ Axle Trucks		
Eastridge Avenue			60						56	42	1	0	4	
			24	1	3					741	656	9	1	23
			36	2	6	9	15			24	10	0	1	4
			2	0	2	539	680	1219	In	821	708	10	2	31
			34	2	4	525	637	1428	Out	813	695	6	2	35
	0	0	0	3	3		Total	1634	1403	16	4	66		
		4+ Axle Trucks	0	34	2	3	3		Eastridge Avenue					
	3 Axle Trucks	0	2	0	2	4	11							
	2 Axle Trucks	0	4	2	6	9	20							
	Passenger Cars	3	525	11	637	1219	20							
	Total in PCE	3	637	20	1428	1428	20							
		Total	55	33	22	12	9	1	Total in PCE	Passenger Cars	2 Axle Trucks	3 Axle Trucks	4+ Axle Trucks	
			27	14	13	9	3	1						
			0	0	0	0	0	0						
			2	2	0	0	0	0						
			8	5	3	1	2	0						
		Box Springs Boulevard												

PCE Factors

- Passenger Cars = 1 PCE
- 2 Axle Trucks = 1.5 PCE
- 3 Axle Trucks = 2 PCE
- 4+ Axle Trucks = 3 PCE

9. I-215 Ramps / Eastridge-Eucalyptus Ave

Count Date: 7/7/2015
 Peak Hour: 7:15-8:15 AM
 PHF: 0.930

		I-215 Ramps															
	4+ Axle Trucks	36	0	7	43	39	82										
	3 Axle Trucks	3	0	0	3	1	4										
	2 Axle Trucks	12	0	4	16	6	22										
	Passenger Cars	172	0	133	305	285	590										
	Total in PCE	304	0	160	464	414	878										
					In	Out	Total										
Eastridge-Eucalyptus Ave		91	49	3	4	20	29										
		42	1	9	190	1086	1276										
		33	0	3	30	134											
Eastridge-Eucalyptus Ave		1	0	4	99	108											
		8	1	2	61	90											
								In	Out	Total							
	4+ Axle Trucks	1078	401	677	472	0	205										
	3 Axle Trucks	971	351	620	427	0	193										
	2 Axle Trucks	18	12	6	4	0	2										
	Passenger Cars	1	1	0	0	0	0										
	Total in PCE	26	10	16	13	0	3										
																	
								In	Out	Total							
	Total in PCE	1557	473	1084	1032	17	8										
	Passenger Cars	1457	425	1032	290	10	2										
	2 Axle Trucks	27	10	17	10	1	1										
	3 Axle Trucks	1	0	1	0	0	0										
	4+ Axle Trucks	19	11	8	2	0	0										

- PCE Factors**
 Passenger Cars = 1 PCE
 2 Axle Trucks = 1.5 PCE
 3 Axle Trucks = 2 PCE
 4+ Axle Trucks = 3 PCE

9. I-215 Ramps / Eastridge-Eucalyptus Ave

Count Date: 7/7/2015
 Peak Hour: 4:30-5:30 PM
 PHF: 0.949

		I-215 Ramps											
		↙		↓		↘							
4+ Axle Trucks		23	0	0	23	30	53						
3 Axle Trucks		2	0	0	2	0	2						
2 Axle Trucks		1	0	3	4	5	9						
Passenger Cars		381	1	466	848	475	1323						
Total in PCE		456	1	471	928	573	1501						
Total													
Total in PCE													
Passenger Cars													
2 Axle Trucks													
3 Axle Trucks													
4+ Axle Trucks													

		I-215 Ramps											
		↙		↑		↘							
Total		1523	837	686	124	1	561						
Total in PCE		1442	802	640	92	1	547						
Passenger Cars		14	4	10	1	0	9						
2 Axle Trucks		1	1	0	0	0	0						
3 Axle Trucks		19	9	10	10	0	0						
4+ Axle Trucks													

		I-215 Ramps											
		↙		↓		↘							
Total		1523	837	686	124	1	561						
Total in PCE		1442	802	640	92	1	547						
Passenger Cars		14	4	10	1	0	9						
2 Axle Trucks		1	1	0	0	0	0						
3 Axle Trucks		19	9	10	10	0	0						
4+ Axle Trucks													

		I-215 Ramps											
		↙		↓		↘							
Total		1523	837	686	124	1	561						
Total in PCE		1442	802	640	92	1	547						
Passenger Cars		14	4	10	1	0	9						
2 Axle Trucks		1	1	0	0	0	0						
3 Axle Trucks		19	9	10	10	0	0						
4+ Axle Trucks													

PCE Factors

- Passenger Cars = 1 PCE
- 2 Axle Trucks = 1.5 PCE
- 3 Axle Trucks = 2 PCE
- 4+ Axle Trucks = 3 PCE

Average Daily Traffic Data

Roadway Segment Average Daily Traffic (not PCE)

Street	From	To	Project Only					Cumulative (2018) Only													
			Pass. Cars	2 Axle Trucks (not PCE)	3 Axle Trucks (not PCE)	4+ Axle Trucks (not PCE)	Total (not PCE)	Pass. Cars	2 Axle Trucks (not PCE)	3 Axle Trucks (not PCE)	4+ Axle Trucks (not PCE)	Total (not PCE)									
Fair Isle Drive-Box Springs Road	Sycamore Canyon Boulevard	I-215 Northbound Ramps	111	4	5	14	134	1515	11	5	14	1545									
Sycamore Canyon Boulevard	Fair Isle Drive	I-215 Southbound Ramps	335	4	5	14	358	1358	25	13	34	1430									
Sycamore Canyon Boulevard	I-215 Southbound Ramps	Dan Kipper Drive	372	8	10	28	418	1522	30	16	42	1610									
Sycamore Canyon Boulevard	Dan Kipper Drive	Box Springs Boulevard	223	4	5	14	246	1505	52	47	120	1724									
Sycamore Canyon Boulevard	Box Springs Boulevard	Sierra Ridge Drive	223	4	5	14	246	1443	65	54	137	1699									
Sycamore Canyon Boulevard	Sierra Ridge Drive	Eastridge Avenue	1120	148	198	526	1992	1419	64	54	136	1673									
Eastridge Avenue	Sycamore Canyon Boulevard	Box Springs Boulevard	820	124	166	444	1554	1187	52	46	116	1401									
Eastridge Avenue	Box Springs Boulevard	I-215 Ramps	820	124	166	444	1554	2228	159	97	243	2727									

Street	From	To	Existing					Existing Plus Project													
			Pass. Cars	2 Axle Trucks (not PCE)	3 Axle Trucks (not PCE)	4+ Axle Trucks (not PCE)	Total (not PCE)	Pass. Cars	2 Axle Trucks (not PCE)	3 Axle Trucks (not PCE)	4+ Axle Trucks (not PCE)	Total (not PCE)									
Fair Isle Drive-Box Springs Road	Sycamore Canyon Boulevard	I-215 Northbound Ramps	12075	410	30	175	12690	12186	414	35	189	12824									
Sycamore Canyon Boulevard	Fair Isle Drive	I-215 Southbound Ramps	14530	400	25	200	15155	14865	404	30	214	15513									
Sycamore Canyon Boulevard	I-215 Southbound Ramps	Dan Kipper Drive	12785	200	100	305	13390	13157	208	110	333	13808									
Sycamore Canyon Boulevard	Dan Kipper Drive	Box Springs Boulevard	12340	200	90	295	12925	12563	204	95	309	13171									
Sycamore Canyon Boulevard	Box Springs Boulevard	Sierra Ridge Drive	9425	150	35	330	9940	9648	154	40	344	10186									
Sycamore Canyon Boulevard	Sierra Ridge Drive	Eastridge Avenue	10715	140	60	305	11220	11835	288	258	831	13212									
Eastridge Avenue	Sycamore Canyon Boulevard	Box Springs Boulevard	12300	130	50	600	13080	13120	254	216	1044	14634									
Eastridge Avenue	Box Springs Boulevard	I-215 Ramps	14175	130	35	690	15030	14995	254	201	1134	16584									

Street	From	To	Existing Plus Ambient Growth (2018)					Existing Plus Ambient Growth (2018) Plus Project					Existing Plus Ambient Growth (2018) Plus Cumulative Projects					Existing Plus Ambient (2018) Plus Cumulative Plus Proj				
			Pass. Cars	2 Axle Trucks (not PCE)	3 Axle Trucks (not PCE)	4+ Axle Trucks (not PCE)	Total (not PCE)	Pass. Cars	2 Axle Trucks (not PCE)	3 Axle Trucks (not PCE)	4+ Axle Trucks (not PCE)	Total (not PCE)	Pass. Cars	2 Axle Trucks (not PCE)	3 Axle Trucks (not PCE)	4+ Axle Trucks (not PCE)	Total (not PCE)	Pass. Cars	2 Axle Trucks (not PCE)	3 Axle Trucks (not PCE)	4+ Axle Trucks (not PCE)	Total (not PCE)
Fair Isle Drive-Box Springs Road	Sycamore Canyon Boulevard	I-215 Northbound Ramps	12800	435	32	186	13453	12911	439	37	200	13587	14315	446	37	200	14998	14426	450	42	214	15132
Sycamore Canyon Boulevard	Fair Isle Drive	I-215 Southbound Ramps	15402	424	27	212	16065	15737	428	32	226	16423	16760	449	40	246	17495	17095	453	45	260	17853
Sycamore Canyon Boulevard	I-215 Southbound Ramps	Dan Kipper Drive	13552	212	106	323	14193	13924	220	116	351	14611	15074	242	122	365	15803	15446	250	132	393	16221
Sycamore Canyon Boulevard	Dan Kipper Drive	Box Springs Boulevard	13080	212	95	313	13700	13303	216	100	327	13946	14585	264	142	433	15424	14808	268	147	447	15670
Sycamore Canyon Boulevard	Box Springs Boulevard	Sierra Ridge Drive	9991	159	37	350	10537	10214	163	42	364	10783	11434	224	91	487	12236	11657	228	96	501	12482
Sycamore Canyon Boulevard	Sierra Ridge Drive	Eastridge Avenue	11358	148	64	323	11893	12478	296	262	849	13885	12777	212	118	459	13566	13897	360	316	985	15558
Eastridge Avenue	Sycamore Canyon Boulevard	Box Springs Boulevard	13038	138	53	636	13865	13858	262	219	1080	15419	14225	190	99	752	15266	15045	314	265	1196	16820
Eastridge Avenue	Box Springs Boulevard	I-215 Ramps	15026	138	37	731	15932	15846	262	203	1175	17486	17254	297	134	974	18659	18074	421	300	1418	20213

APPENDIX D

Signal Warrant Worksheets

Signal Warrants Report For Intersection #4: Sycamore Canyon Boulevard (NS) / Dan Kipper Drive (EW)

Warrants Summary

Warrant #	Name	Met?
#1	Eight Hour Vehicular Volume	No
#2	Four Hour Vehicular Volume	No
#3	Peak Hour	No

Intersection Warrants Parameters

Major Approaches	S, N
Minor Approaches	W
Speed > 40mph	Yes
Population < 10,000	Yes
Warrant Factor	70%

Warrant Analysis Traffic Volumes

Hour	Major Streets		Minor Streets	
	S	N	W	
1	1776	570	2	
2	1705	547	2	
3	1669	536	2	
4	1421	456	2	
5	1350	433	2	
6	1208	388	1	
7	1119	359	1	
8	1066	342	1	
9	832	274	1	
10	799	257	1	
11	799	257	1	
12	764	245	1	
13	693	222	1	
14	639	205	1	
15	639	205	1	
16	622	200	1	
17	335	114	0	
18	195	63	0	
19	178	57	0	
20	71	23	0	
21	43	17	0	
22	53	17	0	
23	36	11	0	
24	36	11	0	

Warrant Analysis by Hour

Hour	Major Lanes		Minor Lanes		Warrant 1 Condition A					Warrant 1 Condition B					Warrant 2		Warrant 3	
	Number	Volume	Number	Volume	100%	80%	70%	56%	100%	80%	70%	56%	100%	80%	70%	56%	Condition B	
1	3	2345	1	2	No	No	No	No	No	No	No	No	No	No	No	No	No	No
2	3	2252	1	2	No	No	No	No	No	No	No	No	No	No	No	No	No	No
3	3	2205	1	2	No	No	No	No	No	No	No	No	No	No	No	No	No	No
4	3	1877	1	2	No	No	No	No	No	No	No	No	No	No	No	No	No	No
5	3	1783	1	2	No	No	No	No	No	No	No	No	No	No	No	No	No	No
6	3	1596	1	1	No	No	No	No	No	No	No	No	No	No	No	No	No	No
7	3	1478	1	1	No	No	No	No	No	No	No	No	No	No	No	No	No	No
8	3	1408	1	1	No	No	No	No	No	No	No	No	No	No	No	No	No	No
9	3	1128	1	1	No	No	No	No	No	No	No	No	No	No	No	No	No	No
10	3	1056	1	1	No	No	No	No	No	No	No	No	No	No	No	No	No	No
11	3	1056	1	1	No	No	No	No	No	No	No	No	No	No	No	No	No	No
12	3	1009	1	1	No	No	No	No	No	No	No	No	No	No	No	No	No	No
13	3	915	1	1	No	No	No	No	No	No	No	No	No	No	No	No	No	No
14	3	844	1	1	No	No	No	No	No	No	No	No	No	No	No	No	No	No
15	3	844	1	1	No	No	No	No	No	No	No	No	No	No	No	No	No	No
16	3	822	1	1	No	No	No	No	No	No	No	No	No	No	No	No	No	No
17	3	469	1	0	No	No	No	No	No	No	No	No	No	No	No	No	No	No
18	3	258	1	0	No	No	No	No	No	No	No	No	No	No	No	No	No	No
19	3	235	1	0	No	No	No	No	No	No	No	No	No	No	No	No	No	No
20	3	94	1	0	No	No	No	No	No	No	No	No	No	No	No	No	No	No
21	3	70	1	0	No	No	No	No	No	No	No	No	No	No	No	No	No	No
22	3	70	1	0	No	No	No	No	No	No	No	No	No	No	No	No	No	No
23	3	47	1	0	No	No	No	No	No	No	No	No	No	No	No	No	No	No
24	3	47	1	0	No	No	No	No	No	No	No	No	No	No	No	No	No	No
Hours Met					0	0	0	0	0	0	0	0	0	0	0	0	0	0

Warrant 3 Condition A

Orientation	W
Total Stopped Delay Per Vehicle on Minor Approach (s)	12.2
Number of Lanes on Minor Street Approach	1
Vehicle Hours of Stopped Delay on Minor Approach (h:hh:mm)	0:00
Delay Condition Met	No
Volume on Minor Street Approach During Same Hour	2
High Minor Volume Condition Met	No
Total Entering Volume on All Approaches During Same Hour	2348
Number of Approaches on Intersection	3
Total Volume Condition Met	Yes
Warrant Met for Approach	No
Warrant Met for Intersection	No

Signal Warrants Report For Intersection #4: Sycamore Canyon Boulevard (NS) / Dan Kipper Drive (EW)

Warrants Summary		
Warrant #	Name	Met?
#1	Eight Hour Vehicular Volume	No
#2	Four Hour Vehicular Volume	No
#3	Peak Hour	No

Intersection Warrants Parameters	
Major Approaches	S, N
Minor Approaches	W
Speed > 40mph	Yes
Population < 10,000	Yes
Warrant Factor	70%

Hour	Major Streets		Minor Streets	
	S	N	W	
1	900	489	1	
2	864	469	1	
3	846	460	1	
4	720	391	1	
5	634	372	1	
6	612	333	1	
7	597	308	1	
8	540	293	1	
9	432	235	0	
10	405	220	0	
11	405	220	0	
12	387	210	0	
13	351	191	0	
14	324	176	0	
15	324	176	0	
16	315	171	0	
17	180	98	0	
18	69	54	0	
19	50	49	0	
20	36	20	0	
21	27	15	0	
22	27	15	0	
23	18	10	0	
24	18	10	0	

Warrant Analysis by Hour

Hour	Major Lanes		Minor Lanes		Warrant 1 Condition A				Warrant 1 Condition B				Warrant 2 Condition B		Warrant 3 Condition B		
	Number	Volume	Number	Volume	100%	80%	70%	56%	100%	80%	70%	55%	100%	80%		70%	55%
1	3	1389	1	1	No	No	No	No	No	No	No	No	No	No	No	No	No
2	3	1333	1	1	No	No	No	No	No	No	No	No	No	No	No	No	No
3	3	1306	1	1	No	No	No	No	No	No	No	No	No	No	No	No	No
4	3	1111	1	1	No	No	No	No	No	No	No	No	No	No	No	No	No
5	3	1056	1	1	No	No	No	No	No	No	No	No	No	No	No	No	No
6	3	945	1	1	No	No	No	No	No	No	No	No	No	No	No	No	No
7	3	875	1	1	No	No	No	No	No	No	No	No	No	No	No	No	No
8	3	833	1	1	No	No	No	No	No	No	No	No	No	No	No	No	No
9	3	667	1	0	No	No	No	No	No	No	No	No	No	No	No	No	No
10	3	625	1	0	No	No	No	No	No	No	No	No	No	No	No	No	No
11	3	625	1	0	No	No	No	No	No	No	No	No	No	No	No	No	No
12	3	597	1	0	No	No	No	No	No	No	No	No	No	No	No	No	No
13	3	542	1	0	No	No	No	No	No	No	No	No	No	No	No	No	No
14	3	500	1	0	No	No	No	No	No	No	No	No	No	No	No	No	No
15	3	500	1	0	No	No	No	No	No	No	No	No	No	No	No	No	No
16	3	486	1	0	No	No	No	No	No	No	No	No	No	No	No	No	No
17	3	278	1	0	No	No	No	No	No	No	No	No	No	No	No	No	No
18	3	153	1	0	No	No	No	No	No	No	No	No	No	No	No	No	No
19	3	139	1	0	No	No	No	No	No	No	No	No	No	No	No	No	No
20	3	56	1	0	No	No	No	No	No	No	No	No	No	No	No	No	No
21	3	42	1	0	No	No	No	No	No	No	No	No	No	No	No	No	No
22	3	42	1	0	No	No	No	No	No	No	No	No	No	No	No	No	No
23	3	28	1	0	No	No	No	No	No	No	No	No	No	No	No	No	No
24	3	28	1	0	No	No	No	No	No	No	No	No	No	No	No	No	No
Hours Met					0	0	0	0	0	0	0	0	0	0	0	0	0

Warrant 3 Condition A

Orientation		W
Total Stopped Delay Per Vehicle on Minor Approach (s)		12
Number of Lanes on Minor Street Approach		1
Vehicle Hours of Stopped Delay on Minor Approach (h:hh:mm)		0:00
Belay Condition Met		No
Volume on Minor Street Approach During Same Hour		1
High Minor Volume Condition Met		No
Total Entering Volume on All Approaches During Same Hour		1390
Number of Approaches on Intersection		3
Total Volume Condition Met		Yes
Warrant Met for Approach		No
Warrant Met for Intersection		No

Signal Warrants Report For Intersection #4: Sycamore Canyon Boulevard (NS) / Dan Kipper Drive (EW)

Warrants Summary			
Warrant	Name	Met?	
#1	Eight Hour Vehicular Volume	No	
#2	Four Hour Vehicular Volume	No	
#3	Peak Hour	No	

Intersection Warrants Parameters

Major Approaches	S, N
Minor Approaches	W
Speed > 40mph	Yes
Population < 10,000	Yes
Warrant Factor	70%

Warrant Analysis Traffic Volumes

Hour	Major Streets			Minor Streets	
	S	N	W	W	
1	1788	594	2		
2	1716	570	2		
3	1881	588	2		
4	1430	475	2		
5	1559	451	2		
6	1216	404	1		
7	1226	374	1		
8	1673	356	1		
9	838	285	1		
10	895	267	1		
11	895	267	1		
12	789	255	1		
13	697	232	1		
14	644	214	1		
15	644	214	1		
16	638	208	1		
17	338	119	0		
18	107	65	0		
19	179	59	0		
20	24	24	0		
21	54	18	0		
22	54	18	0		
23	36	12	0		
24	36	12	0		

Warrant Analysis by Hour

Hour	Major Lanes		Minor Lanes		Warrant 1 Condition A					Warrant 1 Condition B			Warrant 2	Warrant 3
	Number	Volume	Number	Volume	100%	80%	70%	56%	100%	80%	70%	56%	Condition B	Condition B
1	3	2382	1	2	No	No	No	No	No	No	No	No	No	No
2	3	2286	1	2	No	No	No	No	No	No	No	No	No	No
3	3	2239	1	2	No	No	No	No	No	No	No	No	No	No
4	3	1905	1	2	No	No	No	No	No	No	No	No	No	No
5	3	1810	1	2	No	No	No	No	No	No	No	No	No	No
6	3	1620	1	1	No	No	No	No	No	No	No	No	No	No
7	3	1500	1	1	No	No	No	No	No	No	No	No	No	No
8	3	1429	1	1	No	No	No	No	No	No	No	No	No	No
9	3	1143	1	1	No	No	No	No	No	No	No	No	No	No
10	3	1072	1	1	No	No	No	No	No	No	No	No	No	No
11	3	1072	1	1	No	No	No	No	No	No	No	No	No	No
12	3	1024	1	1	No	No	No	No	No	No	No	No	No	No
13	3	929	1	1	No	No	No	No	No	No	No	No	No	No
14	3	856	1	1	No	No	No	No	No	No	No	No	No	No
15	3	856	1	1	No	No	No	No	No	No	No	No	No	No
16	3	834	1	1	No	No	No	No	No	No	No	No	No	No
17	3	477	1	0	No	No	No	No	No	No	No	No	No	No
18	3	262	1	0	No	No	No	No	No	No	No	No	No	No
19	3	238	1	0	No	No	No	No	No	No	No	No	No	No
20	3	96	1	0	No	No	No	No	No	No	No	No	No	No
21	3	72	1	0	No	No	No	No	No	No	No	No	No	No
22	3	72	1	0	No	No	No	No	No	No	No	No	No	No
23	3	48	1	0	No	No	No	No	No	No	No	No	No	No
24	3	48	1	0	No	No	No	No	No	No	No	No	No	No
Hours Met					0	0	0	0	0	0	0	0	0	0

Warrant 3 Condition A

Orientation	W
Total Stopped Delay Per Vehicle on Minor Approach (s)	12.3
Number of Lanes on Minor Street Approach	1
Vehicle Hours of Stopped Delay on Minor Approach (h:hh:mm)	0:00
Delay Condition Met	No
Volume on Minor Street Approach During Same Hour	2
High Minor Volume Condition Met	No
Total Entering Volume on All Approaches During Same Hour	2384
Number of Approaches on Intersection	3
Total Volume Condition Met	Yes
Warrant Met for Approach	No
Warrant Met for Intersection	No

Signal Warrants Report For Intersection #4: Sycamore Canyon Boulevard (NS) / Dan Kipper Drive (EW)

Warrants Summary			
Warrant #	Name	Met?	
#1	Eight Hour Vehicular Volume	No	
#2	Four Hour Vehicular Volume	No	
#3	Peak Hour	No	

Intersection Warrants Parameters

Major Approaches	S, N
Minor Approaches	W
Speed > 40mph	Yes
Population < 10,000	Yes
Warrant Factor	70%

Warrant Analysis Traffic Volumes

Hour	Major Streets			Minor Streets	
	S	N	W		
1	925	501	1		
2	888	481	1		
3	870	471	1		
4	740	401	1		
5	703	381	1		
6	639	341	1		
7	533	316	1		
8	555	301	1		
9	444	240	0		
10	416	225	0		
11	416	225	0		
12	398	215	0		
13	381	195	0		
14	333	180	0		
15	333	180	0		
16	324	175	0		
17	185	100	0		
18	102	55	0		
19	53	50	0		
20	37	20	0		
21	28	15	0		
22	28	15	0		
23	19	10	0		
24	19	10	0		

Warrant Analysis by Hour

Hour	Major Lanes		Minor Lanes		Warrant 1 Condition A					Warrant 1 Condition B					Warrant 2		Warrant 3		
	Number	Volume	Number	Volume	100%	80%	70%	56%	100%	80%	70%	56%	56%	70%	80%	100%	Condition B	Condition B	
1	3	1426	1	1	No	No	No	No	No	No	No	No	No	No	No	No	No	No	No
2	3	1369	1	1	No	No	No	No	No	No	No	No	No	No	No	No	No	No	No
3	3	1341	1	1	No	No	No	No	No	No	No	No	No	No	No	No	No	No	No
4	3	1141	1	1	No	No	No	No	No	No	No	No	No	No	No	No	No	No	No
5	3	1084	1	1	No	No	No	No	No	No	No	No	No	No	No	No	No	No	No
6	3	970	1	1	No	No	No	No	No	No	No	No	No	No	No	No	No	No	No
7	3	899	1	1	No	No	No	No	No	No	No	No	No	No	No	No	No	No	No
8	3	856	1	1	No	No	No	No	No	No	No	No	No	No	No	No	No	No	No
9	3	684	1	0	No	No	No	No	No	No	No	No	No	No	No	No	No	No	No
10	3	641	1	0	No	No	No	No	No	No	No	No	No	No	No	No	No	No	No
11	3	641	1	0	No	No	No	No	No	No	No	No	No	No	No	No	No	No	No
12	3	613	1	0	No	No	No	No	No	No	No	No	No	No	No	No	No	No	No
13	3	566	1	0	No	No	No	No	No	No	No	No	No	No	No	No	No	No	No
14	3	513	1	0	No	No	No	No	No	No	No	No	No	No	No	No	No	No	No
15	3	513	1	0	No	No	No	No	No	No	No	No	No	No	No	No	No	No	No
16	3	469	1	0	No	No	No	No	No	No	No	No	No	No	No	No	No	No	No
17	3	285	1	0	No	No	No	No	No	No	No	No	No	No	No	No	No	No	No
18	3	157	1	0	No	No	No	No	No	No	No	No	No	No	No	No	No	No	No
19	3	143	1	0	No	No	No	No	No	No	No	No	No	No	No	No	No	No	No
20	3	57	1	0	No	No	No	No	No	No	No	No	No	No	No	No	No	No	No
21	3	43	1	0	No	No	No	No	No	No	No	No	No	No	No	No	No	No	No
22	3	43	1	0	No	No	No	No	No	No	No	No	No	No	No	No	No	No	No
23	3	29	1	0	No	No	No	No	No	No	No	No	No	No	No	No	No	No	No
24	3	29	1	0	No	No	No	No	No	No	No	No	No	No	No	No	No	No	No
Hours Met					0	0	0	0	0	0	0	0	0	0	0	0	0	0	0

Warrant 3 Condition A

Total Stopped Delay Per Vehicle on Minor Approach (s)	W	12.1
Number of Lanes on Minor Street Approach		1
Vehicle Hours of Stopped Delay on Minor Approach (h:hh:mm)		0:00
Delay Condition Met		No
Volume on Minor Street Approach During Same Hour		1
High Minor Volume Condition Met		No
Total Entering Volume on All Approaches During Same Hour		1427
Number of Approaches on Intersection		3
Total Volume Condition Met		Yes
Warrant Met for Approach		No
Warrant Met for Intersection		No

Signal Warrants Report For Intersection #4: Sycamore Canyon Boulevard (NS) / Dan Kipper Drive (EW)

Warrants Summary

Warrant #	Name	Met?
#1	Eight Hour Vehicular Volume	No
#2	Four Hour Vehicular Volume	No
#3	Peak Hour	No

Intersection Warrants Parameters

Major Approaches	S, N
Minor Approaches	W
Speed > 40mph	Yes
Population < 10,000	Yes
Warrant Factor	70%

Warrant Analysis Traffic Volumes

Hour	Major Streets		Minor Streets	
	S	N	W	
1	1695	628	2	
2	1619	603	2	
3	1781	590	2	
4	1516	502	2	
5	1440	477	2	
6	1289	427	1	
7	1794	396	1	
8	1137	377	1	
9	910	301	1	
10	853	283	1	
11	853	283	1	
12	815	270	1	
13	739	245	1	
14	632	226	1	
15	632	226	1	
16	683	220	1	
17	379	126	0	
18	208	69	0	
19	190	63	0	
20	76	25	0	
21	57	19	0	
22	57	19	0	
23	38	13	0	
24	38	13	0	

Warrant Analysis by Hour

Hour	Major Lanes		Minor Lanes		Warrant 1 Condition A					Warrant 1 Condition B					Warrant 2	Warrant 3
	Number	Volume	Number	Volume	100%	80%	70%	56%	100%	80%	70%	56%	56%	Condition B		
1	3	2523	1	2	No	No	No	No	No	No	No	No	No	No	No	
2	3	2422	1	2	No	No	No	No	No	No	No	No	No	No	No	
3	3	2371	1	2	No	No	No	No	No	No	No	No	No	No	No	
4	3	2018	1	2	No	No	No	No	No	No	No	No	No	No	No	
5	3	1917	1	2	No	No	No	No	No	No	No	No	No	No	No	
6	3	1716	1	1	No	No	No	No	No	No	No	No	No	No	No	
7	3	1590	1	1	No	No	No	No	No	No	No	No	No	No	No	
8	3	1514	1	1	No	No	No	No	No	No	No	No	No	No	No	
9	3	1211	1	1	No	No	No	No	No	No	No	No	No	No	No	
10	3	1136	1	1	No	No	No	No	No	No	No	No	No	No	No	
11	3	1136	1	1	No	No	No	No	No	No	No	No	No	No	No	
12	3	1085	1	1	No	No	No	No	No	No	No	No	No	No	No	
13	3	984	1	1	No	No	No	No	No	No	No	No	No	No	No	
14	3	908	1	1	No	No	No	No	No	No	No	No	No	No	No	
15	3	808	1	1	No	No	No	No	No	No	No	No	No	No	No	
16	3	883	1	1	No	No	No	No	No	No	No	No	No	No	No	
17	3	505	1	0	No	No	No	No	No	No	No	No	No	No	No	
18	3	277	1	0	No	No	No	No	No	No	No	No	No	No	No	
19	3	253	1	0	No	No	No	No	No	No	No	No	No	No	No	
20	3	101	1	0	No	No	No	No	No	No	No	No	No	No	No	
21	3	76	1	0	No	No	No	No	No	No	No	No	No	No	No	
22	3	76	1	0	No	No	No	No	No	No	No	No	No	No	No	
23	3	51	1	0	No	No	No	No	No	No	No	No	No	No	No	
24	3	51	1	0	No	No	No	No	No	No	No	No	No	No	No	
Hours Met					0	0	0	0	0	0	0	0	0	0	0	

Warrant 3 Condition A

Orientation	W
Total Stopped Delay Per Vehicle on Minor Approach (s)	12.7
Number of Lanes on Minor Street Approach	1
Vehicle Hours of Stopped Delay on Minor Approach (h:hh:mm)	0:00
Delay Condition Met	No
Volume on Minor Street Approach During Same Hour	2
High Minor Volume Condition Met	No
Total Entering Volume on All Approaches During Same Hour	2525
Number of Approaches on Intersection	3
Total Volume Condition Met	Yes
Warrant Met for Approach	No
Warrant Met for Intersection	No

Signal Warrants Report For Intersection #4: Sycamore Canyon Boulevard (NS) / Dan Kipper Drive (EW)

Signal Warrants Report For Intersection #4: Sycamore Canyon Boulevard (NS) / Dan Kipper Drive (EW)

Warrant Analysis by Hour

Warrant Analysis by Hour

Hour	Major Lanes		Minor Lanes		Warrant 1 Condition A					Warrant 1 Condition B			Warrant 2	Warrant 3
	Number	Volume	Number	Volume	100%	80%	70%	56%	100%	80%	70%	56%	Condition B	
1	3	1509	1	1	No	No	No	No	No	No	No	No	No	No
2	3	1449	1	1	No	No	No	No	No	No	No	No	No	No
3	3	1418	1	1	No	No	No	No	No	No	No	No	No	No
4	3	1207	1	1	No	No	No	No	No	No	No	No	No	No
5	3	1147	1	1	No	No	No	No	No	No	No	No	No	No
6	3	1026	1	1	No	No	No	No	No	No	No	No	No	No
7	3	951	1	1	No	No	No	No	No	No	No	No	No	No
8	3	905	1	1	No	No	No	No	No	No	No	No	No	No
9	3	724	1	0	No	No	No	No	No	No	No	No	No	No
10	3	680	1	0	No	No	No	No	No	No	No	No	No	No
11	3	680	1	0	No	No	No	No	No	No	No	No	No	No
12	3	649	1	0	No	No	No	No	No	No	No	No	No	No
13	3	589	1	0	No	No	No	No	No	No	No	No	No	No
14	3	543	1	0	No	No	No	No	No	No	No	No	No	No
15	3	543	1	0	No	No	No	No	No	No	No	No	No	No
16	3	529	1	0	No	No	No	No	No	No	No	No	No	No
17	3	302	1	0	No	No	No	No	No	No	No	No	No	No
18	3	166	1	0	No	No	No	No	No	No	No	No	No	No
19	3	151	1	0	No	No	No	No	No	No	No	No	No	No
20	3	60	1	0	No	No	No	No	No	No	No	No	No	No
21	3	45	1	0	No	No	No	No	No	No	No	No	No	No
22	3	45	1	0	No	No	No	No	No	No	No	No	No	No
23	3	31	1	0	No	No	No	No	No	No	No	No	No	No
24	3	31	1	0	No	No	No	No	No	No	No	No	No	No
Hours Met					0	0	0	0	0	0	0	0	0	0

Warrant	Name	Met?
#1	Eight Hour Vehicular Volume	No
#2	Four Hour Vehicular Volume	No
#3	Peak Hour	No

Major Approaches	Minor Approaches	Speed > 40mph	Population < 10,000	Warrant Factor
S, N	W	Yes	Yes	70%

Major Streets	Minor Streets
S, N	W

Hour	S	N
1	979	530
2	940	509
3	920	498
4	783	424
5	714	403
6	686	360
7	617	334
8	537	318
9	470	254
10	411	239
11	411	239
12	421	228
13	332	207
14	332	191
15	332	191
16	343	186
17	196	106
18	108	58
19	58	53
20	39	21
21	29	16
22	29	16
23	11	11
24	20	11

Hour	S	N
1	979	530
2	940	509
3	920	498
4	783	424
5	714	403
6	686	360
7	617	334
8	537	318
9	470	254
10	411	239
11	411	239
12	421	228
13	332	207
14	332	191
15	332	191
16	343	186
17	196	106
18	108	58
19	58	53
20	39	21
21	29	16
22	29	16
23	11	11
24	20	11

Hour	Major Lanes	Minor Lanes	Warrant 1 Condition A	Warrant 1 Condition B	Warrant 2	Warrant 3
1	3	1509	1	1	No	No
2	3	1449	1	1	No	No
3	3	1418	1	1	No	No
4	3	1207	1	1	No	No
5	3	1147	1	1	No	No
6	3	1026	1	1	No	No
7	3	951	1	1	No	No
8	3	905	1	1	No	No
9	3	724	1	0	No	No
10	3	680	1	0	No	No
11	3	680	1	0	No	No
12	3	649	1	0	No	No
13	3	589	1	0	No	No
14	3	543	1	0	No	No
15	3	543	1	0	No	No
16	3	529	1	0	No	No
17	3	302	1	0	No	No
18	3	166	1	0	No	No
19	3	151	1	0	No	No
20	3	60	1	0	No	No
21	3	45	1	0	No	No
22	3	45	1	0	No	No
23	3	31	1	0	No	No
24	3	31	1	0	No	No
Hours Met					0	0

Hour	Major Streets	Minor Streets
1	S, N	W
2	S, N	W
3	S, N	W
4	S, N	W
5	S, N	W
6	S, N	W
7	S, N	W
8	S, N	W
9	S, N	W
10	S, N	W
11	S, N	W
12	S, N	W
13	S, N	W
14	S, N	W
15	S, N	W
16	S, N	W
17	S, N	W
18	S, N	W
19	S, N	W
20	S, N	W
21	S, N	W
22	S, N	W
23	S, N	W
24	S, N	W

Warrant 3 Condition A

Warrant 3 Condition A

Orientation	W
Total Stopped Delay Per Vehicle on Minor Approach (s)	12.4
Number of Lanes on Minor Street Approach	1
Vehicle Hours of Stopped Delay on Minor Approach (h:hh:mm)	0:00
Delay Condition Met	No
Volume on Minor Street Approach During Same Hour	1
High Minor Volume Condition Met	No
Total Entering Volume on All Approaches During Same Hour	1510
Number of Approaches on Intersection	3
Total Volume Condition Met	Yes
Warrant Met for Approach	No
Warrant Met for Intersection	No

Orientation	W
Total Stopped Delay Per Vehicle on Minor Approach (s)	12.4
Number of Lanes on Minor Street Approach	1
Vehicle Hours of Stopped Delay on Minor Approach (h:hh:mm)	0:00
Delay Condition Met	No
Volume on Minor Street Approach During Same Hour	1
High Minor Volume Condition Met	No
Total Entering Volume on All Approaches During Same Hour	1510
Number of Approaches on Intersection	3
Total Volume Condition Met	Yes
Warrant Met for Approach	No
Warrant Met for Intersection	No

Signal Warrants Report For Intersection #4: Sycamore Canyon Boulevard (NS) / Dan Kipper Drive (EW)

Warrants Summary		
Warrant #	Name	Met?
#1	Eight Hour Vehicular Volume	No
#2	Four Hour Vehicular Volume	No
#3	Peak Hour	No

Intersection Warrants Parameters	
Major Approaches	S, N
Minor Approaches	W
Speed > 40mph	Yes
Population < 10,000	Yes
Warrant Factor	70%

Hour	Major Streets			Minor Streets		
	S	N	W	W	N	W
1	1545	743	15			
2	1667	713	14			
3	1628	698	14			
4	1556	594	12			
5	1478	565	11			
6	1323	505	10			
7	1225	468	9			
8	1167	446	9			
9	934	357	7			
10	875	334	7			
11	875	334	7			
12	836	319	6			
13	759	290	6			
14	700	267	5			
15	700	267	5			
16	681	260	5			
17	389	149	3			
18	214	82	2			
19	195	74	2			
20	78	30	1			
21	89	21	0			
22	88	22	0			
23	59	15	0			
24	59	15	0			

Warrant Analysis by Hour

Hour	Major Lanes		Minor Lanes		Warrant 1 Condition A					Warrant 1 Condition B					Warrant 2	Warrant 3
	Number	Volume	Number	Volume	100%	80%	70%	56%	100%	80%	70%	56%	56%	Condition B		
1	3	2688	1	15	No	No	No	No	No	No	No	No	No	No	No	
2	3	2580	1	14	No	No	No	No	No	No	No	No	No	No	No	
3	3	2526	1	14	No	No	No	No	No	No	No	No	No	No	No	
4	3	2150	1	12	No	No	No	No	No	No	No	No	No	No	No	
5	3	2043	1	11	No	No	No	No	No	No	No	No	No	No	No	
6	3	1828	1	10	No	No	No	No	No	No	No	No	No	No	No	
7	3	1693	1	9	No	No	No	No	No	No	No	No	No	No	No	
8	3	1613	1	9	No	No	No	No	No	No	No	No	No	No	No	
9	3	1291	1	7	No	No	No	No	No	No	No	No	No	No	No	
10	3	1209	1	7	No	No	No	No	No	No	No	No	No	No	No	
11	3	1209	1	7	No	No	No	No	No	No	No	No	No	No	No	
12	3	1155	1	6	No	No	No	No	No	No	No	No	No	No	No	
13	3	1049	1	6	No	No	No	No	No	No	No	No	No	No	No	
14	3	967	1	5	No	No	No	No	No	No	No	No	No	No	No	
15	3	867	1	5	No	No	No	No	No	No	No	No	No	No	No	
16	3	941	1	5	No	No	No	No	No	No	No	No	No	No	No	
17	3	538	1	3	No	No	No	No	No	No	No	No	No	No	No	
18	3	296	1	2	No	No	No	No	No	No	No	No	No	No	No	
19	3	269	1	2	No	No	No	No	No	No	No	No	No	No	No	
20	3	108	1	1	No	No	No	No	No	No	No	No	No	No	No	
21	3	80	1	0	No	No	No	No	No	No	No	No	No	No	No	
22	3	80	1	0	No	No	No	No	No	No	No	No	No	No	No	
23	3	54	1	0	No	No	No	No	No	No	No	No	No	No	No	
24	3	54	1	0	No	No	No	No	No	No	No	No	No	No	No	
Hours Met					0	0	0	0	0	0	0	0	0	0	0	

Warrant 3 Condition A

Orientation	W
Total Stopped Delay Per Vehicle on Minor Approach (s)	22.5
Number of Lanes on Minor Street Approach	1
Vehicle Hours of Stopped Delay on Minor Approach (h:hh:mm)	0:05
Delay Condition Met	No
Volume on Minor Street Approach During Same Hour	15
High Minor Volume Condition Met	No
Total Entering Volume on All Approaches During Same Hour	2703
Number of Approaches on Intersection	3
Total Volume Condition Met	Yes
Warrant Met for Approach	No
Warrant Met for Intersection	No

Signal Warrants Report For Intersection #4: Sycamore Canyon Boulevard (NS) / Dan Kipper Drive (EW)

Warrants Summary		
Warrant #	Name	Met?
#1	Eight Hour Vehicular Volume	No
#2	Four Hour Vehicular Volume	No
#3	Peak Hour	No

Intersection Warrants Parameters	
Major Approaches	S, N
Minor Approaches	W
Speed > 40mph	Yes
Population < 10,000	Yes
Warrant Factor	70%

Hour	Major Streets		Minor Streets	
	S	N	W	
1	1683	577	40	
2	1640	554	38	
3	1618	542	38	
4	896	462	32	
5	833	439	30	
6	768	392	27	
7	682	364	25	
8	650	346	24	
9	520	277	19	
10	487	260	18	
11	487	260	18	
12	466	248	17	
13	422	225	16	
14	390	208	14	
15	390	208	14	
16	379	202	14	
17	217	115	8	
18	119	63	4	
19	108	58	4	
20	43	23	2	
21	32	21	1	
22	32	17	1	
23	22	12	1	
24	22	12	1	

Warrant Analysis by Hour

Hour	Major Lanes		Minor Lanes		Warrant 1 Condition A					Warrant 1 Condition B			Warrant 2	Warrant 3
	Number	Volume	Number	Volume	100%	80%	70%	56%	100%	80%	70%	56%		Condition B
1	3	1660	1	40	No	No	No	No	No	No	No	No	No	No
2	3	1594	1	38	No	No	No	No	No	No	No	No	No	No
3	3	1560	1	38	No	No	No	No	No	No	No	No	No	No
4	3	1528	1	32	No	No	No	No	No	No	No	No	No	No
5	3	1262	1	30	No	No	No	No	No	No	No	No	No	No
6	3	1128	1	27	No	No	No	No	No	No	No	No	No	No
7	3	1046	1	25	No	No	No	No	No	No	No	No	No	No
8	3	996	1	24	No	No	No	No	No	No	No	No	No	No
9	3	797	1	19	No	No	No	No	No	No	No	No	No	No
10	3	747	1	18	No	No	No	No	No	No	No	No	No	No
11	3	747	1	18	No	No	No	No	No	No	No	No	No	No
12	3	714	1	17	No	No	No	No	No	No	No	No	No	No
13	3	647	1	16	No	No	No	No	No	No	No	No	No	No
14	3	598	1	14	No	No	No	No	No	No	No	No	No	No
15	3	598	1	14	No	No	No	No	No	No	No	No	No	No
16	3	581	1	14	No	No	No	No	No	No	No	No	No	No
17	3	332	1	8	No	No	No	No	No	No	No	No	No	No
18	3	182	1	4	No	No	No	No	No	No	No	No	No	No
19	3	166	1	4	No	No	No	No	No	No	No	No	No	No
20	3	66	1	2	No	No	No	No	No	No	No	No	No	No
21	3	49	1	1	No	No	No	No	No	No	No	No	No	No
22	3	49	1	1	No	No	No	No	No	No	No	No	No	No
23	3	34	1	1	No	No	No	No	No	No	No	No	No	No
24	3	34	1	1	No	No	No	No	No	No	No	No	No	No
Hours Met					0	0	0	0	0	0	0	0	0	0

Warrant 3 Condition A

Orientation	W
Total Stopped Delay Per Vehicle on Minor Approach (s)	17.3
Number of Lanes on Minor Street Approach	1
Vehicle Hours of Stopped Delay on Minor Approach (h:hh:mm)	0:11
Delay Condition Met	No
Volume on Minor Street Approach During Same Hour	40
High Minor Volume Condition Met	No
Total Entering Volume on All Approaches During Same Hour	1700
Number of Approaches on Intersection	3
Total Volume Condition Met	Yes
Warrant Met for Approach	No
Warrant Met for Intersection	No