

**AGREEMENT FOR ATTACHMENT OF WIRELINE AND WIRELESS
FACILITIES BETWEEN CITY OF RIVERSIDE AND UNIVERSITY OF
CALIFORNIA RIVERSIDE**

This Agreement for Attachment of Wireline and Wireless Facilities (“Agreement”) is made and entered into on this _____ day of _____, 2024 (the “Effective Date”), by and between the City of Riverside, a California charter city and municipal corporation (“City”) and THE REGENTS OF THE UNIVERSITY OF CALIFORNIA, a California public corporation, on behalf of the UNIVERSITY OF CALIFORNIA, RIVERSIDE, one of its ten campuses (“Licensee”). The City and Licensee sometimes hereinafter referred to individually as a “Party” and together as “the Parties”).

RECITALS

A. The City owns, operates and maintains certain electric utility poles and street light poles, easements associated with these structures and public rights-of-ways. The City also owns and operates a municipal electric utility, also known as a “publicly-owned utility” (“POU”).

B. California law provides that “telegraph or telephone corporations may construct lines of telegraph or telephone lines along and upon any public road or highway, along or across any of the waters or lands within this State, and may erect poles, posts, piers, or abutments for supporting the insulators, wires, and other necessary fixtures of their lines, in such manner and at such points as not to incommode the public use of the road or highway or interrupt the navigation of the waters.” California law further provides that “municipalities can exercise reasonable control as to the time, place, and manner in which roads, highways, and waterways are accessed”, so long as the control is applied to all entities in the same way. (Public Utilities Code sections 7901 and 7901.1.) California law further provides that the City shall allow video service providers that hold a state franchise to install, construct and maintain a network within public rights-of-way. (Public Utilities Code section 5885.)

C. California law provides that POU’s are required to make available space and capacity on the POU’s electric utility poles available for use by communication providers, including cable television corporations and video services providers, and limits the annual fees charged by the POU’s. (Public Utilities Code sections 9510 et seq.)

D. The City also wishes to offer nonexclusive access to City-owned street light poles consistent with all applicable health and safety requirements, including California Public Utilities Commission General Order 95. Neither federal nor California law prohibits the City from charging a fee for such access. Such access is currently regulated by the Federal Communications Commission’s Declaratory Ruling and Third Report and Order (WT Docket No. 17-79; WC Docket No. 17-84, also known as the “the FCC Wireless Infrastructure Order”), which clarifies that Sections 253 and 332(c)(7) of the Communications Act applies to state and local regulation of wireless infrastructure deployment, including the identification of specific fee levels, for small wireless facility deployments in the rights-of-way and attached to certain property owned or controlled by state or local government within the rights-of-way, including City-owned street light poles.

E. In order to keep the number of poles on public thoroughfares and elsewhere to a practicable minimum, Licensee is encouraged to not erect any pole of its own in or near any location where the City has sufficient facilities to accommodate Licensee’s equipment or where a City street light can be replaced by Licensee at Licensee’s cost with a street light that is structurally able to accommodate Licensee’s equipment.

F. This Agreement, along with applicable law, establishes a framework under which Licensee will have access to certain City Facilities and City-provided electrical power for attachment of various wireline and wireless facilities and (if applicable) the construction of facilities within City right-of-way.

In view of the recitals above and with the intention to be legally bound, the Parties agree as follows:

AGREEMENT

Section 1: Background

1.1 The City wishes to grant Licensee, together with its contractors and subcontractors, the non-exclusive use of City Facilities, including (i) the right to attach Network Equipment to the City Facilities, (ii) if applicable, the right to access ROW for installation of Network Equipment, to the extent that the City regulates such access; and (iii) the provision of adequate electrical power for the Network Equipment, as stated herein.

1.2 Licensee wishes, subject to the terms and conditions of this Agreement, to attach Network equipment related to the provision of wireline and wireless communications services to such City Facilities, obtain from the City electrical power for such Network equipment and (if applicable) install Network equipment within City right-of-way. Only Licensees that are “telegraph and telephone corporations”, as defined by Public Utilities Code section 7901, cable corporations and video service providers that hold a state franchise to install, construct and maintain a network within public rights-of-way, as described in Public Utilities Code section 5885, may install Network Equipment within City right-of-way and the City has the sole discretion to not allow Licensees that are not “telegraph and telephone corporations”, cable corporations, or video service providers, to install Network Equipment within City right-of-way, except as otherwise required by law.

1.3 This Agreement shall apply to the following types of attachments or installations, as further described in Exhibit A, entitled “Standards for Review of Attachments or Installation of Network Equipment to City Facilities,” attached hereto and incorporated by reference:

1.4.1 City-owned Utility Poles

1.4.2 City-owned Street Light Poles

1.4.3 Within Public Right of Way, if applicable

1.4 Notwithstanding anything to the contrary herein, this Agreement does not apply to electric utility poles jointly owned by the City and Licensee and governed by the Southern California Joint Pole Agreement and/or the Southern California Joint Pole Committee.

1.5 Licensee shall complete an Application for each individual attachment(s) and/or installations, in the form attached as Exhibit B hereto, and the City’s approval of that Application will be deemed a Supplement to this Agreement, in the form attached as Exhibit B hereto. Licensee may include multiple attachments and/or installations on an Application and the City may issue Supplement for all such attachments and/or installation.

Section 2: Definitions

2.1 [intentionally omitted]

- 2.2** "Application" means that document in substantially the form attached hereto as Exhibit B to be completed by Licensee describing the Network Equipment to be attached by Licensee to City Facilities.
- 2.3** "Attachment" means the physical affixing or connection of Network Equipment, by Licensee and its contractors or agents, to the City Facilities designated pursuant to this Agreement.
- 2.4** "City Facilities" collectively means City Utility Poles and City Street Light Poles. Where the context so requires, "City Facilities" will include Rights-of-Way, either underlying or non-underlying. Unless otherwise specified herein, the term "City Facilities" does not include non-City owned facilities which are being used for wireless service by third parties. This term may also be used singularly or as a plural ("City Facility" or "City Facilities").
- 2.5** "City Street Light Pole" means the street light poles owned and operated by the City, including any Replacement Light Pole approved and accepted by the City. This term excludes traffic signal poles and any City Street Light Poles on which the City has installed traffic signals.
- 2.6** "City Utility Pole" means a City-owned pole used for the generation, transmission, or distribution of electricity, but does not include any utility poles jointly owned by the City and Licensee and governed by the Southern California Joint Pole Agreement and/or the Southern California Joint Pole Committee or any City-owned duct or conduit used for the generation, transmission, or distribution of electricity.
- 2.7** "Construction Permit" means the authorization by the City to Licensee to access and install the Network Equipment on or in City Facilities or City Rights-of-way, as applicable.
- 2.8** "Day" means calendar day unless otherwise specified.
- 2.9** "Emergency Condition" or "Emergency Situation" means any condition, as reported by Licensee or determined by the City that constitutes an unsafe condition or threat to persons or property and/or adversely affects the integrity or operability of the City Facility on or in which Licensee has made an attachment or installation.
- 2.10** "License" means, for purposes of this Agreement, the right, authorization and permission from the City to Licensee by which Licensee may access City Facilities and attach Network Equipment.
- 2.11** "Network" means a Licensee-owned, solely-controlled, operated and/or maintained wireline and/or wireless system for the provisions of telecommunication services or other lawful communication services.
- 2.12** "Network Equipment" shall mean the equipment the Licensee proposes to attach or has attached on City Facilities under this Agreement, as described in each Supplement.
- 2.13** "Otherwise Applicable Tariff" or "OAT" shall mean the City's published electric rate Schedule A-General Service, as amended from time to time, or if Schedule A is modified by the City in such a manner that such rate does not accurately reflect the cost of the electricity provided, then the electric rate that is most appropriate to such electric service, according to the published rate.
- 2.14** "Power Cost Fee" shall mean the fee paid by Licensee for use of City-provided power by attached or installed Network Equipment.

2.15 “Project Manager” means a designated City employee or designee who performs the duties stated herein. City reserves the right to designate multiple City employees to serve as City Project Manager, dependent upon the type of attachment or installation in City ROW.

2.16 “Public Right-of-way” or “ROW” means in, upon, above, along, across, under, and over the public streets, roads, lanes, courts, ways, alleys, boulevards, and places, including, without limitation, all public utility easements and public service easements, as the same now or may thereafter exist that are under the jurisdiction of the City. This term shall not include any property owned by any person or agency other than the City except as provided by applicable laws or pursuant to an agreement between the City and any such person or agency.

2.17 “Replacement Light Pole” means a street light pole, including foundation when required, furnished and installed by Licensee when the City requires a replacement of a City Street Light Pole because the existing street light pole is not structurally able to accommodate Licensee’s equipment.

2.18 “Routine Maintenance” means work done by Licensee on Network Equipment that does not alter, add to or increase the size, location, capacity, appearance or weight of the Network Equipment.

2.19 “Service Drop Line” means a connection by Licensee from a City Facility to Licensee’s customer with no other City Facility located in between the first-referenced City Facility and Customer.

2.20 “Street Opening Permit” means a written permit to perform work in and upon public streets that involves the activities identified in Section 6.1 hereto, including but not limited to any attachments to City Facilities, subject to approval of the City Engineer of the City’s Public Works Department or designee in accordance with the procedure set forth in Section 6.1 of this Agreement. This written permit may also be entitled “Permit to Open a City Street.”

2.21 “Supplement” means that document in substantially the form attached hereto as Exhibit B describing the Network Equipment attached by Licensee to City Facilities. A Supplement shall be effective and incorporated into this Agreement once the Supplement has been approved by the City.

2.22 “Wireless Facility” or “Small Wireless Facilities” shall mean a wireless telecommunications facility including attachments of antennas, as defined by California Government Code section 65850.6(d)(2), which defines such term as “equipment and network components such as towers, utility poles, transmitters, base stations, and emergency power systems that are integral to providing wireless telecommunications services” or a wireless facility that uses licensed or unlicensed spectrum and comprises part of Licensee’s Network, and is attached to a City Utility Pole or Street Light Pole, each of which does not exceed the City’s requirements for such facilities. Wireless Facilities shall also facilities that meet the following conditions:

- (1) The facilities—
 - (i) are mounted on structures 50 feet or less in height including their antennas, or
 - (ii) are mounted on structures no more than 10 percent taller than other adjacent structures, or
 - (iii) do not extend existing structures on which they are located to a height of more than 50 feet or by more than 10 percent, whichever is greater;
- (2) Each antenna associated with the deployment, excluding associated antenna equipment, is no more than three cubic feet in volume or larger at the City’s discretion;
- (3) All other wireless equipment associated with the structure, including the wireless equipment associated with the antenna and any pre-existing associated equipment on the structure, is no more than 28 cubic feet in volume or larger at the City’s discretion;
- (4) The facilities do not require antenna structure registration under the FCC Wireless Infrastructure Order;
- (5) The facilities are not located on Tribal lands, as defined under 36 CFR 800.16(x); and

(6) The facilities do not result in human exposure to radiofrequency radiation in excess of the applicable safety standards specified in the FCC Wireless Infrastructure Order.

2.23 “Wireless service provider” means a provider of “commercial mobile radio service” or “commercial mobile data service,” as those terms are defined in Section 20.3 of Title 47 of the Code of Federal Regulations, using spectrum radio frequencies licensed to it by the Federal Communications Commission or any successor agency.

Section 3: Term (all Attachments)

3.1 Term of Agreement. The initial term of this Agreement shall be for a period of ten (10) years (the “Initial Term”), commencing on the day first written above (the “Effective Date”) and ending on the tenth anniversary thereof, unless sooner terminated as stated herein. This Agreement shall be automatically renewed for up to three (3) successive five (5) year renewal terms (each, a “Renewal Term”), unless Licensee or City notifies the other party in writing of such party’s intent not to renew this Agreement at least ninety (90) days prior to the expiration of the Initial Term or any Renewal Term. The Initial Term and all Renewal Terms shall be collectively referred to herein as the “Term.” However, after the expiration of this Agreement, its term and conditions may continue, at the option of the parties and for a mutually agreed to period of time, as the parties engage in good faith negotiations to further extend the term of the Agreement.

3.2 Term of a Supplement. The initial term for each particular Supplement shall be the first day of the month following the date Licensee has been issued a Supplement for installation of its Network Equipment at a particular location (the “Supplement Commencement Date”) and shall be coterminous with the then-term current term of the Agreement.

3.3 Termination of Agreement or a Supplement. Each Supplement shall automatically be terminated in one year if Licensee has failed to complete construction of the Network Equipment referenced in the Supplement, as further referenced in Section 6. Licensee may also terminate (i) the Agreement, by notifying the City in writing of Licensee’s intent to so terminate at least ninety (90) days prior to the expiration of the then-current term of the Agreement; or (ii) a Supplement upon thirty (30) days prior written notice after Licensee has at any time removed the Network Equipment referenced in the Supplement. City may also terminate the Agreement if Licensee abandons all of its Network Equipment, as provided in Section 9, whether or not Licensee has removed its Network Equipment from such City Facilities or City may terminate a Supplement for abandonment of Network Facilities on a particular City Facility, following removal or non-removal by Licensee, as provided in Section 9. City may also terminate the Agreement for failure to pay annual License Fees, as provided in Section 4.4, in the manner consistent with Section 15.

Section 4: Fees (all Attachments)

4.1 License Fee. In order to compensate the City for Licensee’s entry upon and deployment of Network Equipment within the ROW or on any City Facilities, as applicable, Licensee shall at the commencement of the term of each Supplement pay to the City, on an annual basis, in the amounts set forth in the applicable fee schedule attached hereto to Exhibit C, depending upon the type of attachment. City reserves the right, at any time, to unilaterally amend this agreement to revise such License fees to reflect any changes in Federal or State law.

The City reserves the right to amend the fees for attachments to City Utility Poles, in compliance with California law, and all changes shall become effective in accord with Public Utilities Code sections 9510 et seq. The City further reserves the right to amend the fees for all other attachments or installations of Network Equipment in compliance with federal laws and regulations.

4.2 Power Cost Fee. Reimbursement to the City for Licensee's usage of electrical power shall be billed at Licensee's Otherwise Applicable Tariff, as defined herein. Each attachment shall be separately metered to measure the electricity used by such attachment. Licensee may aggregate attachments under a single meter, with City's approval or as otherwise required by City. Licensee must apply for electric service through the City's Department of Public Utilities, in accord with the published Rules and Rates, and make all payments for such electric service in accord with the published Rules and Rates, including fees for the design and processing of the application for electric service and charges for electrical power.

4.3 Payment. The City shall invoice Licensee for License Fees annually, commencing on January 1st of each year, and Licensee shall pay such invoice, within 45 days from date of receipt of the invoice, by check made payable to the City and mailed or delivered to the Project Manager, at the address provided for in Section 16.9 below. City shall pro-rate all License Fees in accord to commencement date of each Supplement, as applicable. The place and time of payment may be changed at any time by City upon 30 days' written notice to Licensee. Mailed payments shall be deemed paid upon the date such payment is officially postmarked by the United States Postal Service. If postmarks are illegible to read, the payment shall be deemed paid upon actual receipt. Licensee assumes all risk of loss and responsibility for late payment charges if payments are made by mail. Notwithstanding the foregoing, upon agreement of the parties, Licensee may pay the License Fee by electronic funds transfer and in such event, the City agrees to provide to Licensee bank routing information for such purpose upon request of Licensee.

4.4 Delinquent Payment. If Licensee fails to pay any License Fees or other undisputed amounts due pursuant to this Agreement within 45 days from the due date, Licensee shall pay, in addition to the undisputed amount, interest in the amount five percent (5%), for each year and/or fraction thereof during which the payment is due and unpaid.

4.5 Additional Remedies. The remedy provisions set forth in Section 4.4 above are not exclusive, and do not preclude the City from pursuing any other or additional remedy in the event that payments become overdue by more than 45 days.

Section 5: Applications for Attachments to City Facilities

5.1 Written Application. Whenever Licensee shall desire to attach or install Network Equipment upon or in any of the City Facilities, Licensee shall make written application for permission to do so using the Application attached hereto as Exhibit B in the number of copies from time to time prescribed by City. It is the intent of the parties that this Agreement will incorporate only a single Supplement, which is attached hereto as Exhibit B. If Licensee desires to submit an application for additional Supplements, such Supplement will require written amendment to this Agreement and may require City Council approval.

5.2 City Review of Application. City's review of the Application shall conform to the timing and other requirements set forth in California Public Utilities Code section 9511(b) and the FCC Wireless Infrastructure Order, as applicable, and the process for such approval is set forth in Section 6 herein. The City shall review and approve the Application in accord with the terms of this Agreement and applicable law. In the event of a conflict between the terms of the Agreement and the Exhibits, the terms of the Agreement shall prevail. Upon approval, the City shall issue a Supplement describing the Network Equipment permitted under the Supplement.

5.3 Supplement. Upon receiving the City-executed Supplement but not before, and upon payment of the sums required herein, Licensee shall have the right to install, maintain and use its equipment described in the application upon the pole(s) or conduit(s) identified therein, provided, however, that before commencing the installation Licensee shall notify City of the specific time it proposes to do the work sufficiently in advance so City may

arrange to have its representative present when the work is performed. This notification requirement does to apply to Licensee's installation of a Service Drop Line.

Section 6: Review of Applications and Installation

6.1 Permits Required.

6.1.1 The City requires and Licensee must obtain a Street Opening Permit for the following activities:

- (i) Installing new utilities such as gas, electric, water lines, communications (phone, cable, etc.), cellular equipment, etc.
- (ii) Excavating inside the Public right-of-way when proposed by others
- (iii) Performing work and/or construction activities that require traffic control or restricts pedestrians from using the sidewalk areas
- (iv) Tree trimming or landscaping that restricts both vehicular and or pedestrian traffic

Prior to installation or attachment of any Network equipment that will include the activities listed above, and after submission of a written Application, Licensee shall apply for and obtain, or cause to be applied for and obtained, or show proof of existing such permit, from the City a Street Opening Permit authorizing such installation or attachment.

For routine operation and maintenance of Network Equipment that Licensee has installed or attached under this Agreement or another agreement with the City, Licensee may request and City shall issue an annual Street Opening Permit authorizing such routine operation and maintenance activities.

6.1.2 If Licensee makes Attachments or installations of Network equipment to any City Facilities without complying with each and every term of this Agreement, City may, at its option following the expiration of the cure provision in Section 15, immediately remove any or all of such non-conforming Network equipment. Any such removed equipment shall be stored for sixty (60) days by City and disposed of thereafter in a manner to be determined solely by City. The City shall not be responsible for any damage to Network equipment or facilities removed pursuant to this section. Licensee shall reimburse City for all costs of removal and storage incurred, within 30 days of receipt of an invoice detailing the same.

6.2 Engineering Review. Licensee shall submit to City for approval plans and specifications sufficient for City to review the proposed Network equipment and proposed placement and issue a Supplement. For attachments to City Street Light Poles or installation of Replacement Light Poles, such plans and specifications shall be signed and stamped by a California Professional Civil or Structural Engineer. Such plans and specifications shall include, at a minimum, size, weight, mounting method, method of providing electrical power (including placement of any cables), estimated monthly electrical use, radiofrequency radiation, the method of attaching to the City Facility if required for electrical power and compliance with manufacturer's specification for such City Facility. Licensee shall not overload the structural member of any City Facility so as to cause any undue or serious stress or strain to the City Facility, or any part thereof, and shall demonstrate compliance with specifications issued by the manufacturer of such City Facility, if applicable.

Based upon the Licensee plans and specifications referenced above, the City shall have the right, within the applicable time limits, to make a determination whether the City Facility, or any part thereof, will be overloaded by the addition of Licensee's Network Equipment so as to cause undue or serious stress or strain on the City

Facility or any part thereof. The decision of the City shall be final and binding on Licensee and consistent with Cal OSHA rules and regulations, General Orders 95 and 128, and other applicable laws. If Licensee still wishes to install the Network Equipment, it shall pay to replace the City Facility or perform any other work necessary to relieve the stress and/or strain issue, provided that Licensee's proposed Network Equipment are the sole cause of the stress and/or strain. In no event will Licensee be required to pay to replace such City Facility if such Facility was previously under stress and/or strain, nor does the City have any such obligation under this Agreement but may have an obligation to do so under applicable state or federal law, which shall control, as applicable. If any of Licensee's Network Equipment and facilities fails to meet applicable legal or City requirements, and Licensee has caused such failure, Licensee shall promptly, at its own cost, replace such equipment and facilities with compliant equipment and facilities. The City shall review and approve the Application in accord with the Standards attached hereto as Exhibit A and shall only deny access on a nondiscriminatory basis where there is insufficient capacity or for reasons of safety, reliability and generally applicable engineering purposes. If any of Licensee's Network Equipment and facilities are installed in a manner that fails to meet applicable legal or City requirements, and Licensee caused such failure, Licensee shall promptly, at its own cost, replace such equipment and facilities with compliant equipment and facilities.

6.3 "As-is" Condition. Licensee hereby accepts use of the City Facilities in an "as-is" condition, with no warranty, express or implied from City as to any latent, patent and unforeseeable condition of the City Facilities, including its suitability for use by Licensee. Further, Licensee shall have the responsibility to determine, among other things, that the City Facilities that are involved in or related to any of Licensee's work or performance under this Agreement are in full compliance with Cal OSHA rules and regulations, General Orders 95 and 128 and other applicable Laws only to the extent such rules and regulations would have any application whatsoever to Licensee's work or performance under this Agreement, or, if they are not in such compliance, Licensee shall notify Licensor in writing of such fact prior to commencing any work or performance involving or related to said City Facilities. Upon notice of non-compliance and as otherwise required by law, City shall comply with the compliance requirements of Cal OSHA rules and regulations, General Orders 95 and 128 and other applicable Laws.

6.4 Installation. Upon issuance of a Supplement by the City, Licensee may install the Network Equipment and, if applicable, the Replacement Light Pole; provided, such installation is carried out in accord with the terms of this Agreement and the applicable Supplement and other legally required permits. Upon Licensee's completion of the installation and, if applicable, construction of the Replacement Light Pole, the Network Equipment may be inspected by the City to confirm that the installation complies with the terms of this Agreement, the applicable Supplement and any other legally required permits.

6.5 Installation Time Limit. Licensee shall commence attachment or installation of the Network Equipment and the Replacement Light Pole (if applicable) within one year of the date specified in the Supplement. The time periods set forth in this Section 6 may be extended in the sole discretion of the Project Manager or designee.

6.6 No Advertising, Signage or Marks. Except as otherwise permitted by Section 8.5 herein, absent the City's prior written consent, Licensee shall not place any marks, signs, advertisements, notices, decorations, or any other unauthorized devices or Network Equipment in or on City Facilities or the ROW.

6.7 Construction Standards. Licensee Network Equipment shall be installed on and removed from the City Facilities in a good and workmanlike manner without the attachment of any construction liens, as further described in Section 8.12 herein.

6.8 Alterations, Additions, Improvements and Equipment Upgrades. Except for installation of Service Drop Lines for the provision of service to Licensee customers, for Routine Maintenance, or to correct an Emergency

Condition, Licensee shall not make or allow to be made any alterations, additions or improvements to any City Facilities or any part thereof without first obtaining the written consent of the City. If the City consents, all alterations, additions or improvements shall be made at Licensee's sole expense, but in no event will Licensee ever be required to pay to correct pre-existing safety violations caused by City or any other third party, as a condition of access, nor does the City have any obligation under this Agreement to correct pre-existing safety violations but may have an obligation to do so under applicable state or federal law, which shall control, as applicable. Licensee may update or replace the Network Equipment from time to time with prior written notice to the City, provided that (i) the replacement device is no heavier or larger, uses no more electrical power, or creates no greater health, safety, or visual impact, than the model it is replacing; (ii) the method of obtaining electrical power for the device is the same as for the model it is replacing; (iii) the electrical power consumption, size and weight of the updated equipment does not, in the reasonable judgment of the City, place an undue burden on, or risk of damage or injury to, the City Facilities or persons working on or affected by City Licensee; and (iv) any change in their location on the City Facility is approved in writing by City. However, City reserves the right to require Licensee to obtain a Street Opening Permit or show proof of an existing Street Opening Permit for such relocation if the relocation will require certain activities as referenced in Section 6.1.

For wireless equipment Licensee shall submit to the City a detailed proposal for any replacement Network Equipment and any supplemental materials, as may be requested, for the City's evaluation and approval. No equipment upgrade or replacement may be undertaken without an interference review and written approval of the City prior to the installation.

6.9 Replacement Street Light Pole. For replacement of a City Street Light Pole, the Licensee shall be responsible for all costs to design, procure and install a Replacement Light Pole. The Replacement Light Pole shall be subject to the review and approval of the City. Upon completion of its installation and acceptance by City, Replacement Light Pole shall become the City's property. Licensee shall execute any documents required by the City to cause the Replacement Light Pole to transfer of ownership to the City.

In the event a City Street Light Pole has been removed and a Replacement Light Pole for that City Street Light Pole has not been accepted by the City prior to the termination of this Agreement, Licensee shall be responsible for all costs and expenses associated with making such adjustments to the Replacement Light Pole so that it is consistent with City standards. Such light pole shall be subject to the review and approval process set forth herein.

Section 7: Relocation and Displacement of Network.

7.1 Relocations at City's Request. Licensee understands and acknowledges that City may occasionally require Licensee to relocate or remove Network Equipment from one or more of its City Facilities, and Licensee shall at City's direction relocate or remove such at Licensee's sole cost and expense, except as otherwise provided by applicable law, whenever City determines in its sole discretion that the relocation or removal is needed for any of the following purposes: (a) to facilitate the construction, completion, repair, relocation, or maintenance of a City project; (b) to prevent a Network component from interfering with or adversely affecting proper operation of the City Facility referenced in a Supplement or any other City Facility; (c) to prevent interference with the City's use of the ROW; or (d) to protect or preserve the public health or safety. In any such case where Licensee must remove its Network Equipment and such removal is allowed by applicable law, the City shall use its best efforts to afford Licensee a reasonably equivalent alternate location. If Licensee shall fail to relocate or remove any such Network Equipment as requested by the City within sixty (60) days, the City shall be entitled to relocate or remove the same at Licensee's sole cost and expense, upon further notice to Licensee. In such event, the City shall not be responsible for damage to the removed Network Equipment or facility, but shall use reasonable care to preserve such removed Network Equipment until retrieved by Licensee. Licensee shall retrieve such removed Network Equipment within 60 days of City removal, after which City may dispose of such removed Network Equipment

and Licensee shall reimburse City for all costs incurred. If Network Equipment from multiple providers is attached the City Facility, the City shall prioritize the removal of such Network Equipment according to placement on the City Facility, and any time period for such removal shall be appropriately tolled pending removal. Licensee and City shall cooperate to the extent possible to assure continuity of service by Network during relocation of Network Equipment.

7.2 Relocations at Licensee's Request. In the event Licensee desires to relocate or remove any Network Equipment or facility from one City Facility to another, Licensee shall so advise the City. The City will use its best efforts to accommodate Licensee by making another reasonably equivalent City Facility available for use in accordance with and subject to the terms and conditions of this Agreement, at Licensee's sole cost and expense. During any Attachment, if Licensee discovers that the City Facility is unsuitable for any reason, Licensee is authorized to move such to another City Facility which is suitable upon prompt notice to City Project Manager. Such Attachment will not require a separate or new permit application provided that (i) the model has been previously approved by the City; (ii) the replacement device is no heavier or larger, uses no more electrical power, or creates no greater health, safety, or visual impact, than the model it is replacing; (iii) the method of obtaining electrical power for the device is the same as for the model it is replacing; (iv) the electrical power consumption, size and weight of the updated equipment does not, in the reasonable judgment of the City, place an undue burden on, or risk of damage or injury to, the City Facilities or persons working on or affected by City Facilities; and (v) any change in their location to a different City Facility has been approved in writing by the City. However, City reserves the right to require Licensee to obtain a Street Opening Permit or show proof of an existing Permit to Street Opening Permit for such relocation if the relocation will require certain activities as referenced in Section 6.1.

7.3 Damage to City Facility or Rights-of-Way. Whenever the removal or relocation of Network Equipment is required or permitted under this Agreement, and such removal or relocation causes the City Facility to be damaged, Licensee, at its sole cost and expense, shall, promptly repair and return the City Facility in which the Network Equipment is located to a safe and satisfactory condition to the satisfaction of the Project Manager. If Licensee does not repair the site as just described, then the City shall have the option, upon fifteen (15) days' prior written notice to Licensee, to perform or cause to be performed such reasonable and necessary work on behalf of Licensee and to charge Licensee for the proposed costs to be incurred or the actual costs incurred by the City at the City's standard rates. The fifteen (15) days' time period within which the Licensee must repair the site may be extended by mutual agreement of the parties. Upon the receipt of a demand for payment by the City, Licensee shall promptly reimburse the City for such costs. If the actual costs incurred exceed the amount of any payment made by Licensee, City shall reimburse Licensee by the difference.

Section 8: Maintenance and Operation of Network Equipment.

8.1 Repairs and Notification. Any damage done by Licensee to the City Facilities during construction, installation, repairs, relocation and/or during operations of Licensee's Network Equipment shall be repaired or replaced immediately at Licensee's sole cost and expense and to City's sole satisfaction. Licensee shall pay all costs and expenses in relation to maintaining the integrity of the City Facilities in connection with Licensee's construction, installation, repairs, relocation and/or operations of Network Equipment. Except in case of emergency, Licensee shall notify City in advance in writing of Licensee's proposed construction to be performed on the City Facilities in order to coordinate those activities with City's operations. Licensee shall obtain City's written approval of its proposed activities before beginning any work. City's approval shall not be unreasonably withheld.

8.2 Destruction of City Facilities. In the event that a City Facility is rendered unusable through the action of a third party, including, but not limited to, a vehicle involved in a collision with such facility, City's sole responsibility shall be to notify Licensee of such action, and, if necessary, transport any Network Equipment

located or attached to such facility to City's Corporation Yard and make such equipment and facilities immediately available for retrieval by Licensee. City shall use reasonable care to preserve such but shall not be responsible for any damage to the equipment resulting from the transportation or storage as stated herein. Licensee shall be responsible for reattaching the Network Equipment to a City Facility, but has no obligation to do so and may choose to terminate the Supplement referencing that Network Equipment in accord with Section 3.3 herein. The City shall have no responsibility to replace the City Facility with a structure that is capable for accommodating the Network Equipment. If City choose to not replace such City Facility, Licensee shall have the responsibility, but not the obligation, to replace the City Facility rendered unusable with a structure that is capable for accommodating the Network Equipment, subject to City written approval.

8.3 City Repairs to City Facilities or Rights-of-way. City reserves to itself the right to maintain and repair the City Facilities and ROWs and to operate its facilities in such manner as will best enable it to fulfill its own requirements and will use reasonable care not to damage any Network Equipment during such maintenance, but City shall not be liable to Licensee for any interruptions in the operation of the Network Equipment arising in any manner from such maintenance of the City Facilities.

8.4 Nonexclusive License. Licensee understands that this Agreement does not provide Licensee exclusive use of any City Facility and that the City shall have the right to permit other providers of communications or other entities to install equipment or devices in and on City Facilities. The City agrees, however, that in granting others a similar license for nondiscriminatory access to and use of any City Facility, or for the City's own use, the City will take reasonable steps to assure that such additional use does not present any electrical or other interference with the use of the Network or Network Equipment.

8.5 Identification of Licensee Equipment. Licensee shall install and maintain tags on the Network Equipment at each attachment identifying the Licensee's name and contact phone number. Such tagging will be of sufficient size and position so as to be readable from ground level. Licensee shall tag such equipment on a prospective basis as such equipment is installed, and shall tag any equipment already attached to City's poles when performing work on such existing attachments.

8.6 [intentionally omitted]

8.7 Safe Condition and Good Repair. Except as otherwise provided herein, Licensee shall, at its own expense, maintain the Network Equipment in (i) a safe condition, in good repair; (ii) in a manner reasonably satisfactory to City so as not to conflict with the any use of the City Facility by City or the use by a third party of the City Facility that was in existence or otherwise attached to the City Facility prior to the date of the relevant Supplement; and (iii) in conformity with such requirements and specifications as the City may from time to time prescribe and with all applicable laws and regulations, including but not limited to the National Electrical Safety Code. If applicable, Licensee shall also comply with General Orders No. 95 and 128 of the Public Utilities Commission of the State of California and any revisions or supplements thereto. Licensee shall not interfere with the use of the City Facility, related facilities or other equipment of other tenants (that pre-existed Licensee's Network Equipment) in or on the same City Facility. In no event will Licensee be responsible to pay to correct safety violations caused by City or third parties, nor does the City, under this Agreement, have any obligation to correct such safety violations but may have an obligation to do so under applicable state or federal law, which shall control, as applicable.

8.8 Painting of Network. In the event the City undertakes painting on City Facilities, City shall provide fourteen (14) days' written notice to Licensee so that Licensee can take reasonable measures at Licensee's cost to cover or protect Licensee's Network Equipment from paint and debris fallout which may occur during the painting, construction or alteration process.

8.9 Additional Cost. If City elects to make modifications or repairs or work of any other kind to the City Facilities that will cause the City to incur additional cost for work caused solely by the presence of Licensee's Network Equipment on the City Facilities ("Additional Cost"), it will provide ninety (90) days written notice to Licensee and Licensee shall pay City for such Additional Cost. City shall invoice the additional cost to Licensee and Licensee shall pay the Additional Cost within 30 days from date of the invoice. The Additional Cost shall be calculated as the difference between competitive bids obtained by City from responsible contractors to perform the work, and bids to perform the work as though the Network were not present at the City Facilities. As an alternative to payment of Additional Cost, and with City's prior written approval, Licensee may elect to remove temporarily or to relocate its Network Equipment or any portion thereof from the City Facilities at no cost to City. If any work proposed by the City requires the temporary removal or relocation of Licensee's Network Equipment, all costs of removal or relocation shall be paid by Licensee. This provision shall apply equally to all third party attachers and in the event other third parties have Network Equipment or other facilities on any City Facilities, each such party shall pay its pro rata share. Such ninety day notice period shall not apply to modifications, repairs or work of any other kind necessitated by or resulting from an Emergency Conditions. This provision shall not apply and Licensee shall not be required to pay any costs if such modifications, repairs or work are necessary to correct safety violations not caused by Licensee or to accommodate third party attachers, including any communications provider affiliate of the City.

8.10 No Interference. Licensee in the performance and exercise of its rights and obligations under this Agreement shall not interfere with, interrupt or degrade in any manner with the City's use of the City Facilities, any other radio devices used by City forces for other purposes, or the placement of any and all public and private rights of way, sanitary sewers, water mains, storm drains, gas mains, poles, aerial and underground electrical and telephone wires, electroliers, cable television, and other telecommunications equipment, utility facilities, or City property, without the express written approval of the owner or owners of the affected property or properties, except as permitted by applicable Laws or this Agreement. If such interference, interruption or degradation occurs, Licensee shall correct such problem within twenty-four (24) hours of notice by City unless such interference is with a third party attachment or City facility that was not in place at the time of Licensee's installation of its Network Equipment and Licensee has not made any alterations, additions or improvements after the date of such subsequent installations which has resulted in the interference. The time within which Licensee must make corrections may be extended by mutual agreement of the parties. To the extent such is caused by obligations under this Agreement, Parties shall reasonably cooperate to achieve the goals for this Section.

Furthermore, Licensee shall, at its expense, comply with all present and future federal, state, and local laws, ordinances, rules and regulations (including laws and ordinances relating to health, radio frequency emissions, other radiation and safety). The City agrees to reasonably and non-discriminatorily cooperate with Licensee in obtaining, at Licensee's expense (including reimbursement of the City's reasonable attorney and administrative fees), any federal licenses and permits required for or substantially required by Licensee's use of the City Facilities. If required for wireless equipment on City Facilities, Licensee shall obtain written certification from the City that the City Facilities cause no interference or loss of signal of any City owned or operated communications services prior to turning up power and transmitting any signal from the Network Equipment on the City Facilities. Licensee agrees to cooperate with the City to provide and review all technical information including engineering data on intermodulation and power output of Network Equipment to allow a determination by the City of the Network Equipment probable impact on City owned and operated communications facilities. Further, if at any time during the Licensee's use of the City Facilities, it is determined by the City that the Network Equipment are negatively impacting the City's communications facilities, Licensee agrees to immediately shut off power and transmission to and from Network Equipment, until the interference can be resolved by modification of the Network Equipment.

8.11 Ownership Rights. No use, however extended, of any City Facility under this License shall create or vest in Licensee any ownership or property rights. Licensee's rights shall be and remain a mere license which as to

any particular City Facility. Nothing herein contained shall be construed to compel City to maintain any particular City Facility for a period longer than that demanded by its own service requirements.

8.12 Freedom from Liens. Licensee shall keep the City Facilities free from all liens, including mechanics liens, arising from any act or omission of Licensee or those claiming under Licensee. Licensee shall pay as due all claims for work done, and for services rendered or material furnished to the City Facilities at Licensee's request. If Licensee fails to pay any claims or to discharge any liens, City may do so and collect all costs of discharge, including its reasonable attorney fees. Payment or discharge by City shall not constitute a waiver of any right or remedy City may have on account of Licensee's default. Licensee may withhold payment of any claim in connection with a good faith dispute over the obligation to pay, so long as City's property interests are not jeopardized. If a lien is filed as a result of nonpayment, Licensee shall within ten (10) days after knowledge of filing of the lien, provide City with an executed copy of a discharge of the lien, or deposit with City cash or a sufficient corporate surety bond or other security satisfactory to City in an amount sufficient to discharge the lien plus any costs, attorney fees or other charges that could accrue as a result of any foreclosure sale or sale under the lien. This License shall be subject and subordinate to any liens and encumbrances as are now on or as City may hereafter impose on the City Facility. Licensee shall, upon request of City, execute and deliver agreements of subordination consistent with this Section.

Section 9: Discontinuation or Abandonment of Network/Removal Security

9.1 Discontinuation or Abandonment. In the event that all or any portion of the Network Equipment is either abandoned or no longer placed in service for a continuous period of six (6) months or more, City, at its sole option, and without waiving any other available remedy, may require Licensee to promptly remove any or all of the Network at Licensee's sole cost and expense. If Licensee fails to remove such portion of the Network Equipment within thirty (30) days of notice of removal or such time period mutually agreed to in writing by the Parties, the City may remove the facilities at its sole discretion and issue an invoice to the Licensee for this work which Licensee shall pay within thirty (30) days. In addition, the City may deem such Network Equipment abandoned and take possession and ownership of them unless Licensee pays such invoice and removes such Network Equipment from City possession.

9.2 Removal Security. City shall have the right to require Licensee to furnish a bond to cover the faithful performance by Licensee of its obligations under this Agreement. If such a bond is required by City, it shall be issued by a commercial bonding company selected by Licensee which is authorized to transact surety insurance business in the State of California and satisfactory to City; shall not be subject to termination or cancellation except upon ninety (90) days' prior written notice by certified mail to City; shall be in such form and in such amount sufficient to cover the faithful performance by Licensee of its obligations under this Agreement, but shall not be less than \$100,000 and shall not exceed \$250,000; and, subject to termination or cancellation as foresaid, shall be maintained in full force and effect throughout the life of this License. The parties shall mutually agree to the amount of said bond.

If the Surety on the bond referenced herein should give notice of the termination of said bond, or if Licensee should materially default in any of its obligations under this License and such material default shall continue for thirty (30) days after written notice thereof, City may, by a written notice to Licensee, forthwith terminate this License or forthwith terminate any or all permits granted by it hereunder, and Licensee shall remove its equipment from the poles to which said termination applies within ninety (90) days from such notification. The obligations of Licensee shall survive such termination of this License until fully performed by Licensee.

Section 10: Interruptions of Service

For Section 10.1 only, the meaning of “Network Equipment” shall be limited to Wireless Facility Attachments only. At its sole cost and expense, Licensee agrees to install a clearly marked and accessible power "cut-off" switch to be located on or near the Network Equipment. The Licensee may also, but is not required to, install at its sole cost and expense a signal switch which is capable of remotely de-energizing the Network Equipment in the manner required by this Section 10 ("Signal Switch").

10.1 Maintenance. Except in Emergency situations, if maintenance of the City Facilities requires the City’s employees or agents to come within five feet of the Network Equipment **or** within a sufficient distance such that the safety of the employees or agents may be at risk, the City shall notify in advance of this maintenance and request that Licensee temporarily shut off power to the Network Equipment. Licensee shall comply with this request; however, the City will attempt to conduct its activities according to Licensee’s preferred schedule unless that schedule would unreasonably delay maintenance or increase costs. Upon completion of the maintenance, the City shall notify Licensee, and Licensee may then activate the power to the Network Equipment. Except in an Emergency Situation, City will try as much as possible to perform the maintenance or other work in the vicinity of the Network Equipment within twenty-hour (24) hours after City has confirmed that power has been shut off. The City shall not be liable to Licensee or any other party for any interruption in Licensee’s service or interference with the operation of the Network Equipment. In the event that the Network Equipment must be de-energized by the City to ensure the safety of the City’s employees or agents, the following protocol must be followed:

10.1.1 The City shall contact Licensee at the address referenced in Section 16.9 to request the Signal Switch to de-energize the Network Equipment.

10.1.2 Licensee shall thereafter de-energize the Network Equipment by switching off the Signal Switch. Licensee shall respond within twenty–four(24) hours after the City contacts Licensee at the telephone number set forth in Section 15.9. If Licensee is unable to respond within twenty–four(24) hours, the City may de-energize the Network Equipment. In such instances, the City will reenergize the Network Equipment as soon as possible after the City has completed its work. The City may terminate Licensee's use of a City Facility referenced in the same Supplement with five (5) business days’ written notice to Licensee, when Licensee fails to install a “cut-off” switch and cooperate with Licensor to de-energize the Network Equipment as required by this section on three (3) separate occasions within a calendar year.

10.2 Emergency Situations. Licensee understands that the Network Equipment is located on public property and Emergency Situations may develop from time to time that requires power to the Network Equipment to be immediately shut off. Licensee agrees that if an Emergency Situation occurs, the City shall have the right to immediately shut off power to the Network Equipment. Once the work has been completed and the workers have departed the exposure area, the party who accomplished the power-down shall restore power and inform Licensee as soon as possible that power has been restored. Notwithstanding the foregoing, the City will not immediately shut off power to the Network Equipment and follow the de-energize process set forth herein if the Project Manager determines in his sole discretion that (a) the Emergency Situation does not require an immediate shut off of power to the Antennas; and (b) Licensee's employee or agent will perform the shut off of power within a timeframe which will not exacerbate the Emergency Situation. Licensee agrees not to hold the City responsible or liable for and shall protect, defend, and indemnify and hold the City harmless from any damage, loss, claim, or liability of any nature suffered as a result of the loss of the use of the Network Equipment or other communication facilities as a result of de-energization.

Section 11: Representations and Warranties

11.1 City Representations. City represents that, to its knowledge, after due inquiry, it has the right and authority to enter into this Agreement and grant the rights and License contained herein.

11.2 Licensee Representations and Warranties. Licensee represents and warrants to City that, to its knowledge, after due inquiry, (i) it has all licenses, permits and rights authorizing it to enter into this Agreement; (ii) Licensee is duly organized and validly existing under the laws of the state in which it was formed and is qualified to do business in the State of California; (iii) the execution and delivery of this Agreement has been duly authorized by the proper corporate proceedings; (iv) this Agreement constitutes a valid and binding obligation of Licensee enforceable in accordance with its terms; and (v) neither the execution, delivery or performance of this Agreement will violate or conflict with any law, rule, regulation, order, judgment, organization document, instrument or agreement by which Licensee is bound. The individuals executing this Agreement and the instruments referenced herein on behalf of Licensee each represent and warrant that they have the legal power, right and actual authority to bind Licensee to the terms and conditions of this Agreement.

Section 12: Assignment and Transfer

12.1 General. Licensee shall not assign, transfer or sublicense its interest in or obligations under this Agreement without the prior written consent of City, which consent shall not be unreasonably withheld or delayed. Any such attempted assignment, transfer or sublicense by Licensee without City's prior written consent, unless excepted under Section 12.2, shall be void ab initio, and shall constitute an incurable breach of this Agreement entitling City to terminate this Agreement. Licensee agrees it shall not be unreasonable for City to withhold its consent, if:

- a. Assignee's financial condition or technical ability to operate wireless services is equal to Licensee's on the effective date; or
- b. Assignee does not have approved contracts or other arrangements in place on the Assignment Date, to begin use of all City Facilities licensed for use within sixty days after the Assignment; or
- c. Assignee fails to provide adequate documentation to City of Assignee's ability to satisfy the requirements set forth herein.

12.2 Exceptions. Notwithstanding the foregoing, Licensee may assign, transfer or sublicense its interests and obligations hereunder to a parent, wholly-owned or –controlled affiliate, wholly-owned or –controlled subsidiary company, or purchaser of all or substantially all of its assets or stock, without the prior written consent of City and which shall be effective upon written notice to City. Such written notice shall include written information demonstrating that assignees is a parent, wholly-owned or –controlled affiliate, wholly-owned or –controlled subsidiary company, or purchaser of all or substantially all of its assets or stock of Licensee.

Use of Licensee's capacity in wireline facilities or Wireless Facilities by third parties or attachment of third-party owned Wireless Facilities to City Facilities by Licensee pursuant to license agreements between Licensee and such third-party owners shall not constitute an assignment, sublicense, or transfer of rights and obligations under this Agreement. Licensee remains solely responsible and liable for all performance obligations under this Agreement with respect to such Wireless Facilities.

Section 13: Indemnification

13.1 Mutual Indemnity. Licensee will defend, indemnify, and hold harmless City, its officers, employees, and agents, from and against all losses, expenses (including, without limitation, reasonable attorneys' fees and costs), damages, and liabilities of any kind resulting from or arising out of the Agreement, including the performance hereunder of Licensee, its Regents, its officers, employees, and agents, but only in proportion and to the extent that such losses, expenses, damages and liabilities are due or claimed to be due to the acts or omissions of Licensee, its Regents, its officers, employees, or agents.

City will defend, indemnify, and hold harmless Licensee, its Regents, its officers, employees, and agents, from and against all losses, expenses (including, without limitation, reasonable attorneys' fees and costs), damages, and liabilities of any kind resulting from or arising out of the Agreement, including the performance hereunder of City, its officers, employees, and agents, but only in proportion and to the extent that such losses, expenses, damages and liabilities are due or claimed to be due to the acts or omissions of City, its officers, employees, or agents.

13.2 Hazardous Substances Indemnity. Licensee expressly agrees to and shall indemnify, defend, release and hold the City, their officers, officials, directors, agents, servants, employees, harmless from and against any liability, loss, fine, penalty, fee, charge, lien, judgment, damage, entry, claim, cause of action, suit, proceeding (whether legal or administrative), remediation, response, removal, or clean-up and all costs and expenses associated therewith, and all other costs and expenses (including, but not limited to, attorney's fees, expert fees, and court costs) in any way related to the disposal, treatment, transportation, manufacture, or use of any Hazardous Substances which were caused to be placed on, in, under, or about the City Facilities by Licensee, its officers, directors, agents, servants, employees. However, this requirement to indemnify, defend, release and hold harmless specifically excludes any such liability, loss, fine, penalty, fee, charge, lien, judgment, damage, entry, claim, cause of action, suit, proceeding (whether legal or administrative), remediation, response, removal, or clean-up and all costs and expenses associated therewith, and all other costs and expenses (including, but not limited to, attorney's fees, expert fees, and court costs) that are related to the City's, their officers', officials', directors', agents', servants', or employees' own disposal, treatment, transportation, or manufacture of such Hazardous Substances. This indemnity, defense and hold harmless obligation shall survive the expiration or termination of this Agreement, up to the applicable statute of limitations.

City expressly agrees to and shall indemnify, defend, release and hold the Licensee, their officers, officials, directors, agents, servants, employees, harmless from and against any liability, loss, fine, penalty, fee, charge, lien, judgment, damage, entry, claim, cause of action, suit, proceeding (whether legal or administrative), remediation, response, removal, or clean-up and all costs and expenses associated therewith, and all other costs and expenses (including, but not limited to, attorney's fees, expert fees, and court costs) in any way related to the disposal, treatment, transportation, manufacture, or use of any Hazardous Substances which were caused to be placed on, in, under, or about the City Facilities by City, its officers, directors, agents, servants, employees. However, this requirement to indemnify, defend, release and hold harmless specifically excludes any such liability, loss, fine, penalty, fee, charge, lien, judgment, damage, entry, claim, cause of action, suit, proceeding (whether legal or administrative), remediation, response, removal, or clean-up and all costs and expenses associated therewith, and all other costs and expenses (including, but not limited to, attorney's fees, expert fees, and court costs) that are related to the Licensee's, their officers', officials', directors', agents', servants', or employees' own disposal, treatment, transportation, or manufacture of such Hazardous Substances. This indemnity, defense and hold harmless obligation shall survive the expiration or termination of this Agreement, up to the applicable statute of limitations.

13.3 Hazardous Substances Defined. Hazardous Substances shall mean any (a) substance, product, waste or other material of any nature whatsoever which is or becomes listed, regulated, or addressed pursuant to CERCLA, 42 U.S.C. § 9601, *et seq.*; The Hazardous Materials Transportation Act, 49 U.S.C. § 1801, *et seq.*; the Resource Conservation and Recovery Act, 42 U.S.C. § 6901, *et seq.* ("RCRA"); The Toxic Substances Control Act, 15 U.S.C. § 2601 *et seq.*; The Clean Water Act, 33 U.S.C. § 1251, *et seq.*; The Hazardous Waste Control Act, California Health and Safety Code ("H. & S.C.") § 25100, *et seq.*; the Hazardous Substance Account Act, H. & S.C. § 25330, *et seq.*; the California Safe Drinking Water and Toxic Enforcement Act, H. & S.C. § 25249.5, *et seq.*; Underground Storage of Hazardous Substances H. & S.C. § 25280, *et seq.*; the Carpenter-Presley-Tanner Hazardous Substance Account Act (H & S.C. § 25300 *et seq.*); The Hazardous Waste Management Act, H. & S.C. §§ 25170.1, *et seq.*; Hazardous Materials Response Plans and Inventory H. & S.C. § 25001 *et seq.*; or the Porter-Cologne Water Quality Control Act, Water Code § 13000, *et seq.*, all as amended, or any other federal, state or local statute, law, ordinance, resolution, code, rule, regulation, order or decree regulating, relating to, or

imposing liability or standards of conduct concerning, any hazardous, toxic or dangerous waste, substance or material, as now or at any time hereafter in effect, (b) any substance, product, waste or other material of any nature whatsoever which may give rise to liability under any of the above statutes, (c) petroleum, crude oil or any substance which contains gasoline, diesel fuel or other petroleum hydrocarbons other than petroleum and petroleum products contained within regularly operated motor vehicles, and (d) polychlorinated biphenyls (PCB), radon gas, urea-formaldehyde, asbestos and lead.

Section 14: Insurance

14.1 General. Prior to the City's execution of this Agreement, Licensee shall obtain, and shall thereafter maintain during the term of this Agreement, such general liability insurance as required to insure Licensee against damages for personal injury, including accidental death, as well as from claims for property damage for which Licensee may be liable under this Agreement.

14.2 Workers' Compensation Insurance: By executing this Agreement, Licensee is aware of and will comply with Section 3700 of the Labor Code of the State of California requiring every employer to be insured against liability for workers' compensation, or to undertake self-insurance before commencing any of the work. Licensee shall carry the insurance or provide for self-insurance required by California law to protect said Licensee from claims under the Workers' Compensation Act. Prior to the City's execution of this Agreement Licensee shall file with the City either (1) a certificate of insurance showing that such insurance is in effect, or that Licensee is self-insured for such coverage, or (2) a certified statement that Licensee has no employees, and acknowledging that if Licensee does employ any person, the necessary certificate of insurance will immediately be filed with the City. Any certificate filed with the City shall provide that the City will be given ten (10) days' prior written notice before cancellation thereof.

14.3 Commercial General Liability and Automobile Insurance. Prior to the City's execution of this Agreement Licensee shall obtain, and shall thereafter maintain during the term of this Agreement, commercial general liability insurance and automobile liability insurance as required to insure Licensee against damages for personal injury, including accidental death, as well as from claims for property damage, which may arise from or which may concern Licensee operations by anyone directly or indirectly employed by, connected with, or acting for or on behalf of Licensee, or Licensee may provide reasonable evidence of self-insurance for these same limits. The City, and its officers, employees and agents, shall be named as additional insured's under the Licensee's insurance policies. Licensee shall ensure that all of its subcontractors used in the performance of this Agreement, procure and maintain policies of insurance that are appropriate for the type and level of service being provided.

14.3.1 Licensee's commercial general liability insurance policy shall cover both bodily injury (including death) and property damage (including, but not limited to, premises operations liability, products-completed operations liability, independent consultant's liability, personal injury and advertising liability, and contractual liability) in an amount not less than \$1,000,000 per occurrence and a general aggregate limit in the amount of not less than \$2,000,000.

14.3.2 Licensee's automobile liability policy shall cover both bodily injury and property damage in an amount not less than \$1,000,000 per occurrence and an aggregate limit of not less than \$1,000,000. All of Licensee's automobile and/or commercial general liability insurance policies shall cover all vehicles used in connection with Licensee's performance of this Agreement which vehicles shall include, but are not limited to, Licensee owned vehicles, Licensee leased vehicles, Licensee's employee vehicles, non-Licensee owned vehicles and hired vehicles.

14.3.3 Prior to the City's execution of this Agreement, copies of insurance policies or original certificates and additional insured endorsements evidencing the coverage required by this Agreement, for both commercial general and automobile liability insurance, shall be filed with the City and shall include the City and its officers, employees and agents, as additional insureds. Said policies shall be in the usual form of commercial general and automobile liability insurance policies, but shall include the following provisions:

“It is agreed that the City of Riverside, and its officers, employees and agents, are added as additional insured’s under this policy, solely for work done by and on behalf of the named insured for the City of Riverside.”

The insurance policy or policies shall also comply with the following provisions:

(a) The policy shall be endorsed to waive any right of subrogation against the City and its sub-consultants, employees, officers and agents for services performed under this Agreement.

(b) If the policy is written on a claims made basis, the certificate should so specify and the policy must continue, either through policy renewals or the purchase of an extended discovery period, in force for one year after completion of the services. The retroactive date of coverage must also be listed.

(c) The policy shall specify that the insurance provided by Licensee will be considered primary and not contributory to any other insurance available to the City (where included as additional insured)..

The policies shall not be canceled unless thirty (30) days' prior written notification of intended cancellation has been given to the City by certified or registered mail. The City, its agents and employees make no representation that the limits of the insurance specified to be carried by Licensee pursuant to this Agreement are adequate to protect Licensee. If Licensee believes that any required insurance coverage is inadequate, Licensee will obtain such additional insurance coverage, as Licensee deems adequate, at Licensee’s sole expense.

Failure to maintain or provide proof of insurance shall constitute an immediate breach of this Agreement and shall not be construed as a waiver of Licensee’s obligation to provide the required insurance coverage. The coverage and limits of insurance required in this Agreement will not be construed as a limitation of any liability to the City. All insurance policy deductibles, self-insured retentions and retrospective premiums will be the sole responsibility of Licensee.

Section 15: Default.

In the event either Party shall fail to observe or perform any material aspect of the terms and provisions of this Agreement and such failure continues for a period of thirty (30) days after receipt of written notice from the non-defaulting Party (“Default”), then the non-defaulting Party may terminate this Agreement, provided however, that where such Default cannot reasonably be cured within such period, and the defaulting Party has proceeded promptly to cure the same and is prosecuting such cure with diligence, the time for curing such Default shall be extended for an amount of time, an additional thirty (30) days, as may be necessary under the circumstances to complete such cure.

Section 16: General

16.1 Attorneys' Fees and Venue. Any action at law or in equity brought by either of the parties hereto for the purpose of enforcing a right or rights provided for by this Agreement shall be tried in the Superior Court in the County of Riverside, State of California or the United States District Court for the Central District of California. In the event either party hereto shall bring suit to enforce any term of this Agreement or to recover any damages for and on account of the breach of any term or condition of this Agreement, it is mutually agreed that each party will bear their own attorney's fees and costs.

16.2 Third Party Beneficiaries. No person or entity shall be considered a third-party beneficiary to this Agreement. None of the terms or conditions in this Agreement shall give or allow any claim, benefit, or right of action by any third person or entity not a Party hereto.

16.3 No Partnership. The Parties acknowledge and agree that this Agreement does not create a partnership between, or a joint venture of, the City and Licensee.

16.4 Severability. In the event any term, covenant or condition of this Agreement, or the application of such term, covenant or condition, shall be held invalid as to any person or circumstance by any court having jurisdiction, all other terms, covenants and conditions of this Agreement shall not be affected thereby, but shall remain in force and effect unless a court holds that the invalid term, covenant or condition is not separable from all other terms, covenants and conditions of this Agreement.

16.5 Governing Law. This Agreement shall be governed by and construed in accordance with the laws of the State of California without giving effect to the principles of conflicts of laws.

16.6 Force Majeure. Neither Party shall be liable to the other for any failure of performance under this Agreement due to causes beyond its control, including, but not limited to: acts of God, fire, flood or other catastrophes, adverse weather conditions, material or facility shortages or unavailability not resulting from such Party's failure to timely place orders therefore, lack of transportation, the imposition of any governmental codes, ordinances, laws, rules, regulations or restrictions, national emergencies, insurrections, riots, wars, or strikes, lock-outs, work stoppages or other labor difficulties.

16.7 Waiver. No delay or omission by either Party to exercise any right or power occurring upon non-compliance or failure of performance by the other Party shall impair that right or power or be construed to be a waiver. A waiver by either Party of any of the covenants, conditions or obligations to be performed by the other Party under this Agreement shall not be construed to be a general waiver.

16.8 Headings. The Section headings herein are for convenience and reference only, and shall in no way define or limit the scope and content of this Agreement or in any way affect its provisions.

16.9 Notices. Whenever written notice is required or permitted to be given under this Agreement by one Party to the other, it shall be given effect by hand delivery, or by mailing the same by certified mail, return receipt requested, properly addressed and postage pre-paid to the Party to whom given. Notices shall be addressed as follows:

If to the City: City of Riverside Energy Delivery Engineering Division, Public Utilities Department
3901 Orange St
Riverside, CA 92501

If to Licensee: The Regents of the University of California
Real Estate Services

Attention: Thomas Toepfer
1420 Iowa Avenue, Suite 130
Riverside, CA 92507

For Notices issued under Section 10:

The Regents of the University of California
Real Estate Services
Attention: Thomas Toepfer
1420 Iowa Avenue, Suite 130
Riverside, CA 92507

Either Party hereto may at any time designate a different person or address for the purpose of receiving notice by so informing the other Party in writing in accordance with this section. Notice by certified mail shall be deemed given upon actual receipt thereof or three (3) days after being deposited in the United States Mail, whichever first occurs.

16.10 Integrated Agreement and Amendments. This Agreement is an integration of the entire understanding of the Parties with respect to the matters set forth herein. The Parties shall only amend this Agreement in writing with the proper official signatures attached thereto.

16.11 Authorized Representatives. Each Party shall designate a representative who is authorized to act on its behalf in the implementation of this Agreement and with respect to those matters contained herein, which are the functions and responsibilities of the Authorized Representatives. Each Authorized Representative may delegate actual performance of such functions and responsibilities; provided, that any agreement of the Authorized Representatives required to be in writing shall be signed by the Authorized Representatives. Either Party may at any time change the designation of its Authorized Representative by written notice to the other Party.

16.12 Time of the Essence. Time is of the essence for each and every provision of this Agreement.

16.13 Exhibits. The following exhibits attached hereto are incorporated herein to this Agreement by this reference:

Exhibit "A":	Standards for Review of Attachments or Installation of Network Equipment to City Facilities (all attachments)
Exhibit "B":	Application/Supplement (all attachments)
Exhibit "C":	Fee Schedules (all attachments)

The information contained in any such exhibits or any Supplement may be added to, changed, or amended from time to time on the same terms and conditions as reflected in the Agreement subject to the mutual agreement in writing by Licensee's designated representative and, in the case of the City, the Public Utilities General Manager. Such mutual written agreement by each of the Party's designated representative shall be deemed an addition change, or an amendment of this License Agreement not requiring further amendment to the entire License Agreement. In the event of a conflict between the terms of this Agreement, a Supplement and the Exhibits, the terms of this Agreement shall govern.

IN WITNESS WHEREOF, the undersigned have executed this Agreement on the date first written above.

CITY OF RIVERSIDE

LICENSEE

By: _____
Name: _____
Title: _____

By: *[Signature]*
Name: *Ernesto Bernetti*
Title: *Vice Chancellor & Chief Financial Officer*

Attest:

By: _____
City Clerk

Approved as to Form:

By: *[Signature]*
Deputy City Attorney

Exhibit A
Standards for Review of Attachments or Installation of Network Equipment to City
Facilities
(All Attachments)

Exhibit B
Application/Supplement
(All attachments)

Exhibit C-1
Fee Schedules
City Utility Poles

Each application to the City to install any equipment shall be accompanied by a payment to the City of \$67.00 per pole/structure as a one-time fee to process a request for attachment. This fee shall be for the processing of the application and the engineering of the attachments or occupations proposed and the inspection of the work performed and shall not exceed the actual cost of processing the request.

In addition to the processing, engineering, and inspection fees, Licensee shall pay to the City an annual license fee of twenty-three dollars and fifty cents (\$23.50) per foot of occupied usable pole space. The annual fee shall be prorated over the number of months that Licensee has its equipment attached to or occupied in City's facilities commencing with the first day of the month following the date of attachments, and shall be payable in advance, half on the first day of January and half on the first day of July in each year. The annual fee may be changed by the City, in accordance with applicable federal, state or local law, upon ninety (90) days' written notice to Licensee.

Exhibit C-2
Fee Schedule
Street Light Poles and Public Right of Way Access

Each application to the City to install any equipment shall be accompanied by a payment to the City of Five Hundred Dollars (\$500.00) for up to Five Small Wireless Facilities as a one-time fee to process a request for attachment, and an additional One Hundred Dollars (\$100) for each such facility thereafter. This fee shall be for the processing of the application and the engineering of the attachments or occupations proposed and the inspection of the work performed pursuant to Section 6, above, and shall not exceed the actual cost of processing the request.

In addition to the processing, engineering, and inspection fees specified herein, Licensee shall pay to the City an annual license fee of Two Hundred Seventy Dollars (\$270) per attachment, prorated as applicable.

Design Standards for Small Cell Wireless Facilities Mounted on Street Light Poles in the Public Right-of-Way

A. Purpose:

The following provisions are intended to ensure that small cell wireless facilities mounted on street light poles within public rights-of-way are designed in a manner that minimizes aesthetic impacts to public views from the public rights-of-way, and to promote health, safety and walkability of the community.

B. Equipment/Aesthetics:

1. Pole equipment shall be limited to antenna and ancillary equipment.
2. Fourth Generation (4G) Antenna Requirements. Antennas shall be mounted in a concealed canister (cantenna) on top of pole. Antenna size shall be limited as follows:
 - a. 6-foot maximum height above the top of light pole mast arm.
 - b. 14.5-inch maximum width/diameter when any equipment (e.g., a meter pedestal/electric meter) will be ground-mounted.
 - c. 18-inch maximum width/diameter is allowed when the electric meter and all other equipment can be concealed within the cantenna, No ground-mounted equipment allowed with this option.
 - d. A minimum 6-inches is required between the bottom of the cantenna and the attachment location of the streetlight mast arm.
3. Fifth Generation (5G) Antenna Requirements.
 - a. No more than 1 antenna array consisting of 3 individual antennas may be allowed on a pole. Individual antenna size shall be limited as follows:
 - i. 2-foot maximum height.
 - ii. 1-foot maximum width.
 - b. Antennas shall be camouflaged to match and be integrated with the design of the existing light pole.
4. Components and cabling below the antenna shall be shrouded and concealed from public view.
5. To limit obstructions on sidewalks and protect health, safety & walkability, ground mounted equipment, including meter pedestals, shall be located a minimum of 10 feet from light poles. The equipment location should be off-set from poles along the street frontage instead of directly behind light poles.
6. Equipment should be located behind and out of the sidewalk whenever possible.
7. Ground mounted equipment should be located in a landscaped planter whenever feasible, such as within existing landscaped area where appropriate irrigation and maintenance of landscaping exists, or can be accommodated. New planting, should be provided as necessary to soften the appearance of and provide screening of meter pedestals and other ground mounted equipment from

public view. Modifications to existing landscaped areas or new landscape installations in the public right-of-way shall meet the water efficient landscape requirements of Chapter 19.570 of the Zoning Code, if applicable, and be coordinated with and subject to the approval of the City's Public Works Department and Urban Forester.

8. Retaining walls may be necessary and should be utilized as appropriate, such as within sloped landscaped areas, to locate equipment behind sidewalks and aid in screening ground mounted equipment.
9. Meter pedestals shall be accessible by a meter reader in accordance with Riverside Public Utility electric service rules.
10. Meter pedestals and equipment cabinets must meet all applicable Electric Utility Service Equipment Requirements Committee (EUSERC) requirements.
11. Legs, handles, and logos shall be removed from Radio Relay Units & equipment.
12. Signs or advertising devices shall be prohibited, except for certification, warning, or other legally required seals or legally required signage (e.g. RF warning sticker at minimum size & visibility).
13. All equipment/facilities shall comply with ADA requirements.

C. Pole standards:

1. Facilities shall be located on existing/replacement infrastructure instead of on new poles whenever possible.
2. Installation of new poles shall only be allowed when it is not feasible to locate on existing/replacement infrastructure.
3. Facilities shall be limited to mast arm street lights per Riverside Public Utilities approved street light standards.

D. General Requirements:

1. Wireless carriers shall consult with the City's Historic Preservation Division of the Community & Economic Development Department and Title 20 (Cultural Resources) of the Riverside Municipal Code (RMC) to determine if proposed facilities are in a historic district or may affect a historic cultural resource.
2. Facilities shall comply with Title 20 (Cultural Resources) of the RMC when the facility is located on, or in proximity to a cultural resource including all design conforming to historic character.

18" DIA. x 72" MAX
SHROUDED ANTENNA

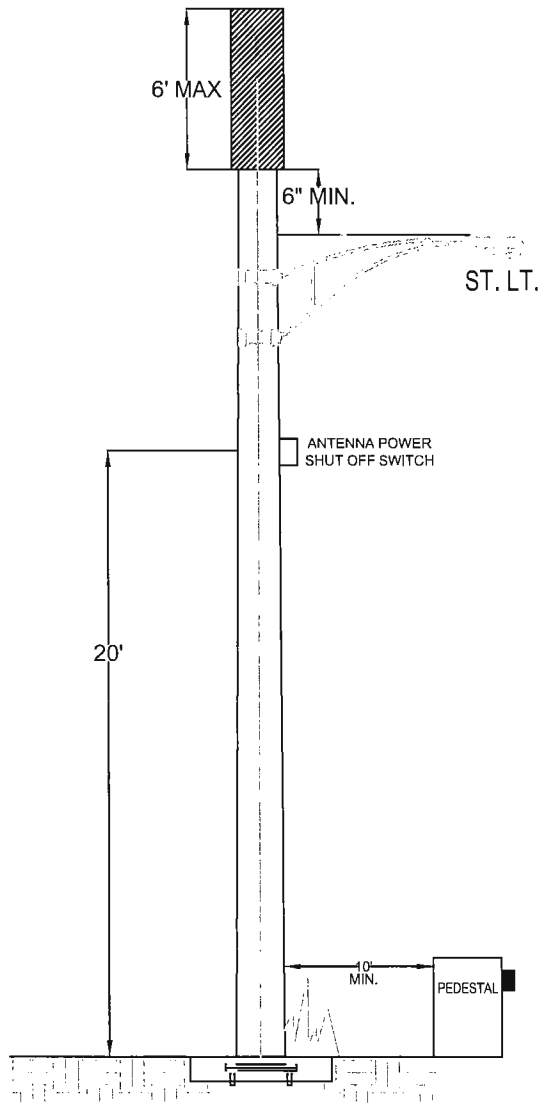

*SPECIFICATION 2-6
UGS-800, 801, 802*

REQUIREMENTS:

1. ANTENNA & EQUIPMENT MUST BE MOUNTED IN A CONCEALED CANISTER ON TOP OF POLE.
2. CANISTER SIZE MUST NOT EXCEED 6' TALL x 18" DIAMETER.
3. ALL CABLING AND COMPONENTS MUST BE CONCEALED FROM PUBLIC VIEW.
4. ELECTRIC METER AND OTHER EQUIPMENT NOT IN CANNISTER MUST BE INSTALLED IN A GROUND MOUNTED, EUSERC APPROVED PEDESTAL/CABINET.
5. SIGNS OR ADVERTISING DEVICES OTHER THAN CERTIFICATION, WARNING, OR OTHER LEGALLY REQUIRED SEALS OR SIGNAGE ARE PROHIBITED (RMC TITLE 19).
6. ALL INSTALLATIONS MUST COMPLY WITH ADA REQUIREMENTS FOR PEDESTRIAN ACCESS.
7. POLE MUST BE DESIGNED TO WITHSTAND THE LOADS IMPARTED BY A CYLINDRICAL 14.5" DIAMETER x 60" TALL ANTENNA SHROUD, THE TOP MOUNT LMA, AND THE LUMINAIRE PER THE 2010 CALIFORNIA BUILDING CODE, ASCE 7-05 & 2013 AASHTO LTS-6 IN A 90MPH WIND ZONE (3-SECOND GUSTS).
8. ANTENNA SHUT OFF SWITCH, FURNISHED AND INSTALLED BY WIRELESS COMPANY.
9. POLE DESIGN & FINISH MUST MATCH EXISTING CITY OF RIVERSIDE STREETLIGHT POLES.
10. INSTALLATION AND WIRING MUST FOLLOW RIVERSIDE STREETLIGHT COSNTRUCTION SPECIFICATION 2-6, UGS-800, UGS-801, UGS-802
11. STREETLIGHT WIRING/FEED MUST BE IN SEPARATE CONDUIT FROM COMMUNICATIONS WIRING/FEED.
12. COMPLIANCE WITH TITLE 20 OF THE RMC MUST BE MET WHEN FACILITY IS LOCATED ON OR IN PROXIMITY TO A CULTURAL RESOURCE.

STREET LIGHT
ANTENNA INSTALLATION
STANDARDS

Design Standards for Small Cell Wireless Facilities Mounted on Utility Poles in the Public Right-of-Way

A. Purpose:

The following provisions are intended to ensure that small cell wireless facilities mounted on utility poles within public rights-of-way are designed in a manner that minimizes aesthetic impacts to public views from the public rights-of-way, and to promote health, safety and walkability of the community.

B. Equipment/Aesthetics:

1. Pole equipment shall be limited to antenna and ancillary equipment.
2. To limit obstructions on sidewalks and protect health, safety & walkability, ground mounted equipment, including meter pedestals, shall be located a minimum of 10 feet from utility poles. The equipment location should be off-set from poles along the street frontage instead of directly behind utility poles.
3. Equipment should be located behind and out of the sidewalk whenever possible.
4. Ground mounted equipment should be located in a landscape planter whenever feasible, such as within an existing landscape area where appropriate irrigation and maintenance of landscaping exists, or can be accommodated. New planting should be provided as necessary to soften the appearance of and provide screening of meter pedestals and other ground mounted equipment from public view. Modifications to existing landscaped areas or new landscape installations in the public right-of-way shall meet the water efficient landscape requirements of Chapter 19.570 of the Zoning Code, if applicable, and be coordinated with and subject to the approval of the City's Public Works Department and Urban Forester.
5. Retaining walls may be necessary and should be utilized as appropriate, such as within sloped landscaped areas, to locate equipment behind sidewalks and aid in screening for ground mounted equipment.
6. Meter pedestals shall be accessible by a meter reader in accordance with Riverside Public Utility electric service rules.
7. Meter pedestals and equipment cabinets must meet all applicable Electric Utility Service Equipment Requirements Committee (EUSERC) requirements.
8. All exposed wiring/cabling must meet G.O. 95 clearance requirements.
9. Legs, handles, and logos shall be removed from Radio Relay Units & equipment.
10. Signs or advertising devices shall be prohibited, except for certification, warning, or other legally required seals or legally required signage (e.g. RF warning sticker at minimum size & visibility).

11. All equipment/facilities shall comply with ADA requirements.

C. Pole standards:

1. Facilities shall be located on existing/replacement utility poles (Riverside Public Utilities (RPU) other utility provider poles) located in the public right-of-way whenever possible.
2. Installation of new utility poles shall only be allowed when it is not feasible to locate on existing/replacement infrastructure.

D. General Requirements:

1. Wireless carriers shall consult with the City's Historic Preservation Division of the Community & Economic Development Department and Title 20 (Cultural Resources) of the Riverside Municipal Code (RMC) to determine if proposed facilities are in a historic district or may affect a historic cultural resource.
2. Facilities shall comply with Title 20 (Cultural Resources) of the RMC when the facility is located on, or in proximity to a cultural resource including all design conforming to historic character.

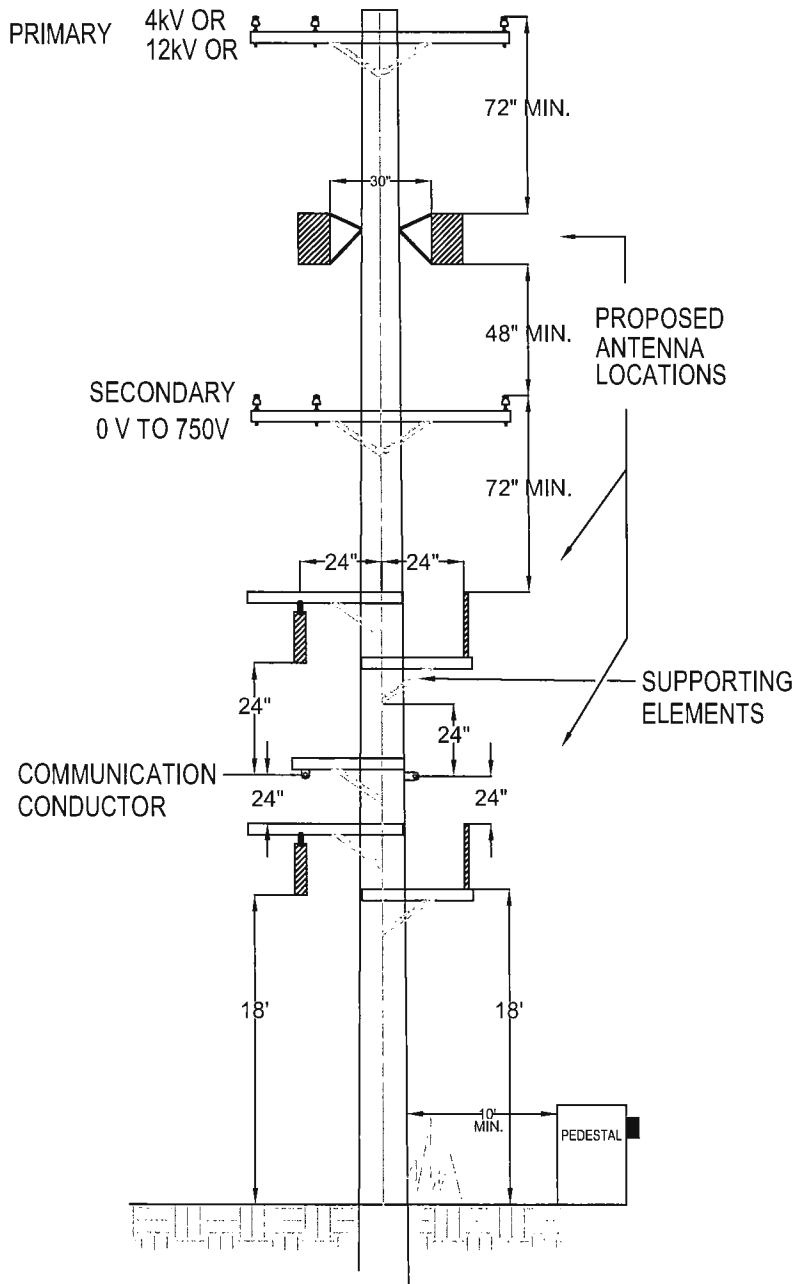

REQUIREMENTS:

1. ALL CLEARANCES MUST COMPLY WITH PUBLIC UTILITIES COMMISSION STATE OF CALIFORNIA GENERAL ORDER No. 95.
2. POLE EQUIPMENT LIMITED TO ANTENNA & STACKED RADIO RELAY UNITS (RRU) ONLY.
3. NO ANTENNAS OR EQUIPMENT ALLOWED ABOVE PRIMARY ELECTRIC CIRCUITS.
4. ELECTRIC METER AND OTHER EQUIPMENT MUST BE INSTALLED IN A GROUND MOUNTED, EUSERC APPROVED PEDESTAL/CABINET.
5. SIGNS OR ADVERTISING DEVICES OTHER THAN CERTIFICATION, WARNING, OR OTHER LEGALLY REQUIRED SEALS OR SIGNAGE ARE PROHIBITED (RMC TITLE 19).
6. ALL INSTALLATIONS MUST COMPLY WITH ADA REQUIREMENTS FOR PEDESTRIAN ACCESS.
7. POLE LOADING CALCULATIONS MUST BE PERFORMED PRIOR TO INSTALLATION.
8. ANTENNA SHUT OFF SWITCH, FURNISHED AND INSTALLED BY WIRELESS COMPANY.
9. COMPLIANCE WITH TITLE 20 OF THE RMC MUST BE MET WHEN FACILITY IS LOCATED ON OR IN PROXIMITY TO A CULTURAL RESOURCE.

*G095, Rule 94
SEE G095, Table 2, Case 21*

**UTILITY POLE
ANTENNA INSTALLATION
STANDARDS**



RIVERSIDE PUBLIC UTILITIES - ELECTRIC

UTILITY POLE ATTACHMENT APPLICATION

NOTE: An executed Pole/Streetlight Attachment Master Agreement must be on file prior to application to attach.*

Application Date: _____
 Site Name/Project #: MLK & UCR PL 30 Crossing
 PW Permit#: _____
 Approved by: _____
 Date: _____

Equipment Owner

Name: Thomas Toepfer
 Address: 1420 Iowa Avenue, Suite 130
 Riverside, CA 92507
 Contact Name: Thomas Toepfer
 Phone #: 951-827-2682

Applicant (if different than owner)

Name: _____
 Address: _____
 Contact Name: _____
 Phone #: _____

Approval of this Application does not constitute approval for Electric Facility Installation; a separate Application for Electric Service Design is required for Electric Service.

SMALL CELL ANTENNA INSTALLATION

Small Cell Antenna Application must be accompanied by Site Plan, Elevation Drawings, Equipment Mounting Details, Pole Loading Calculations, & Make-Ready.

Pole #	Owner (RPU, Joint)	Location/GPS Coordinates	Attachment Grade (Highest Point)	Attachment Grade (Lowest Point)	Equipment Dimensions (HxWxD)	Equipment Weight	Riser		Pole Loading		Transmit Frequency	Receive Frequency	Output Power Level	Operating Voltage	Operating Amperage
							Conduit Size	Pole Quadrant (N,E,S,W)	Bending Safety Factor	Vertical Safety Factor					

Notes:

FIBER/COAX ATTACHMENT

Fiber/Coax Application must be accompanied by Route Map, Pole Loading Calculations, & Make-Ready.

Item #	Pole #	Owner (RPU, Joint)	Location/GPS Coordinates	Attachment Grade	Billable Y/N (within RPU space)	Guy/Anchor Direction	Riser		Pole Loading		Notes
							Conduit Size	Pole Quadrant (N,E,S,W)	Bending Safety Factor	Vertical Safety Factor	
1	18144J	RPU	33.96848° N, 117.33436° W								
2	18145J	RPU	33.96805° N, 117.33416° W								

Notes:

*THIS APPROVED APPLICATION IS A LEGAL SUPPLEMENT TO THE EXECUTED MASTER AGREEMENT