

MAXWELL® IV DRAINAGE SYSTEM DETAIL AND SPECIFICATIONS

ITEM NUMBERS

1. Manhole Cone - Modified Flat Bottom.
2. Moisture Membrane - 6 Mil. Plastic. Applies only when native material is used for backfill. Place membrane securely against eccentric cone and hole sidewall.
3. Bolted Ring & Grate - Diameter as shown. Clean cast iron with wording "Storm Water Only" in raised letters. Bolted in 2 locations and secured to cone with mortar. Rim elevation $\pm 0.02'$ of plans.
4. Graded Basin or Paving (by Others).
5. Compacted Base Material - 1-Sack Slurry except in landscaped installations with no pipe connections.
6. PureFlo® Debris Shield - Rolled 16 ga. steel X 24" length with vented anti-siphon and Internal .265" Max. SWO flattened expanded steel screen X 12" length. Fusion bonded epoxy coated.
7. Pre-cast Liner - 4000 PSI concrete 48" ID. X 54" OD. Center in hole and align sections to maximize bearing surface.
8. Min. 6' \emptyset Drilled Shaft.
9. Support Bracket - Formed 12 Ga. steel. Fusion bonded epoxy coated.
10. Overflow Pipe - Sch. 40 PVC mated to drainage pipe at base seal.
11. Drainage Pipe - ADS highway grade with TRI-A coupler. Suspend pipe during backfill operations to prevent buckling or breakage. Diameter as noted.
12. Base Seal - Geotextile or concrete slurry.
13. Rock - Washed, sized between 3/8" and 1-1/2" to best complement soil conditions.
14. FloFast® Drainage Screen - Sch. 40 PVC 0.120" slotted well screen with 32 slots per row/ft. Diameter varies 120" overall length with TRI-B coupler.
15. Min. 4' \emptyset Shaft - Drilled to maintain permeability of drainage soils.
16. Fabric Seal - U.V. resistant geotextile - to be removed by customer at project completion.
17. Absorbent - Hydrophobic Petrochemical Sponge. Min. to 128 oz. capacity.
18. Freeboard Depth Varies with inlet pipe elevation. Increase settling chamber depth as needed to maintain all inlet pipe elevations above overflow pipe inlet.
19. Optional Inlet Pipe (Maximum 4", by Others). Extend moisture membrane and compacted base material or 1 sack slurry backfill below pipe invert.

The referenced drawing and specifications are available on CAD either through our office or web site. This detail is copyrighted (2004) but may be used as is in construction plans without further release. For information on product application, individual project specifications or site evaluation, contact our Design Staff for no-charge assistance in any phase of your planning.

CALCULATING MAXWELL IV REQUIREMENTS

The type of property, soil permeability, rainfall intensity and local drainage ordinances determine the number and design of MaxWell Systems. For general applications draining retained stormwater, use one standard **MaxWell IV** per the instructions below for up to 3 acres of landscaped contributory area, and up to 1 acre of paved surface. For larger paved surfaces, subdivision drainage, nuisance water drainage, connecting pipes larger than 4" \emptyset from catch basins or underground storage, or other demanding applications, refer to our **MaxWell® Plus** System. For industrial drainage, including gasoline service stations, our **Envibro® System** may be recommended. For additional considerations, please refer to "Design Suggestions For Retention And Drainage Systems" or consult our Design Staff.

COMPLETING THE MAXWELL IV DRAWING

To apply the **MaxWell IV** drawing to your specific project, simply fill in the blue boxes per instructions below. For assistance, please consult our Design Staff.

ESTIMATED TOTAL DEPTH

The Estimated Total Depth is the approximate depth required to achieve 10 continuous feet of penetration into permeable soils. Torrent utilizes specialized "crowd" equipped drill rigs to penetrate difficult, cemented soils and to reach permeable materials at depths up to **180 feet**. Our extensive database of drilling logs and soils information is available for use as a reference. Please contact our Design Staff for site-specific information on your project.

SETTLING CHAMBER DEPTH

On MaxWell IV Systems of over 30 feet overall depth and up to 0.25cfs design rate, the **standard** Settling Chamber Depth is **18 feet**. For systems exposed to greater contributory area than noted above, extreme service conditions, or that require higher design rates, chamber depths up to 25 feet are recommended.

OVERFLOW HEIGHT

The Overflow Height and Settling Chamber Depth determine the effectiveness of the settling process. The higher the overflow pipe, the deeper the chamber, the greater the settling capacity. For normal drainage applications, an overflow height of **13 feet** is used with the standard settling chamber depth of **18 feet**. Sites with higher design rates than noted above, heavy debris loading or unusual service conditions require greater settling capacities

TORRENT RESOURCES INCORPORATED

1509 East Elwood Street, Phoenix Arizona 85040-1391
phone 602-268-0785 fax 602-268-0820
Nevada 702-366-1234

AZ Lic. ROC070465 A, ROC047067 B-4; ADWR 363
CA Lic. 528080 A, C-42, HAZ - NV Lic. 0035350 A - NM Lic. 90504 GF04

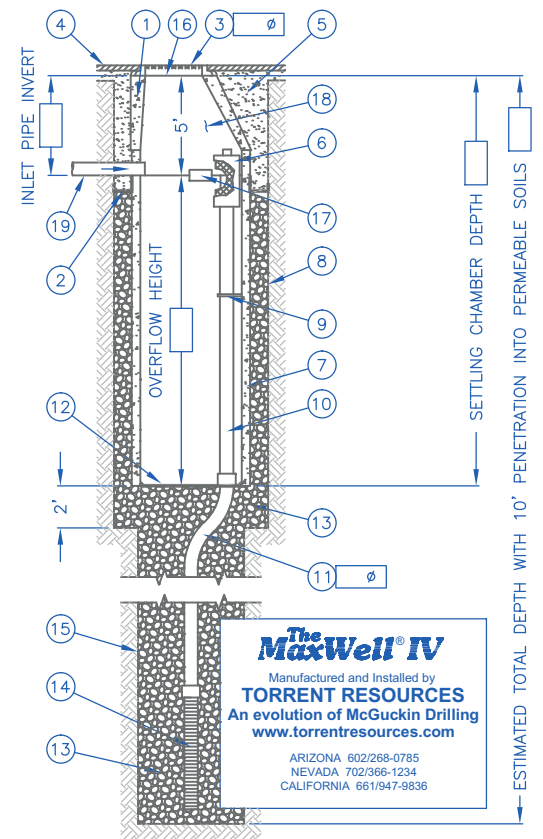

AZ Lic. ROC070465 A, ROC047067 B-4, ADWR 363
CA Lic. 528080, C-42, HAZ,
NV Lic. 0035350 A - NM Lic. 90504 GF04
U.S. Patent No. 4,923,330 - TM Trademark 1974, 1990, 2004

DRAINAGE PIPE

This dimension also applies to the **PureFlo®** Debris Shield, the **FloFast®** Drainage Screen, and fittings. The size selected is based upon system design rates, soil conditions, and the need for adequate venting. Choices are 6", 8", or 12" diameter. Refer to "Design Suggestions for Retention and Drainage Systems" for recommendations on which size best matches your application.

BOLTED RING & GRATE

Standard models are quality cast iron and available to fit 24" \emptyset or 30" \emptyset manhole openings. All units are bolted in two locations with wording "Storm Water Only" in raised letters. For other surface treatments, please refer to "Design Suggestions for Retention and Drainage Systems."

INLET PIPE INVERT

Pipes up to 4" in diameter from catch basins, underground storage, etc. may be connected into the settling chamber. Inverts deeper than 5 feet will require additional settling chamber depth to maintain effective overflow height.

TORRENT RESOURCES (CA) INCORPORATED

phone 661-947-9836
CA Lic. 886759 A, C-42

www.TorrentResources.com

An evolution of McGuckin Drilling

The watermark for drainage solutions.®



The watermark for drainage solutions.®



INDUSTRY SERVICES

SITE DRAINAGE SYSTEMS

TECHNICAL ANALYSIS

RECHARGE SYSTEMS

ENVIRONMENTAL APPS.

DRAINAGE RENOVATION

DRAINAGE MAINTENANCE

COMPANY OVERVIEW

ONLINE RESOURCES

DRAINAGE MAINTENANCE

With over thirty years of experience to draw on, Torrent Resources records clearly show that utilizing regular inspection and cleaning procedures can significantly enhance the service-life and performance of the drainage systems it installs. *Maintenance Data Sheets* accompany all MaxWell and Envibro Systems at the time of completion that provide operational information and instructions for inspection and service.

As a benefit to all MaxWell and Envibro owners, Torrent offers a full range of maintenance programs to protect the investment made in its drainage systems. With thorough knowledge and experience to analyze the operational and structural aspects of our patented products, we can effectively accomplish these basic, yet important services.

Torrent can provide Preventive Maintenance Programs that are tailored for your site including full service contracts. These services would include a preliminary inspection of the settling chambers and internal components and an assessment of the site drainage to insure that the system meets operational guidelines. A written report is provided at the completion of each inspection.

MaxWell system cleaning is accomplished with truck mounted hydro-vactor equipment, utilizing water and air to dislodge and remove debris and sediment deposits. All chambers, inlets, connecting piping and catch basins are cleaned with the contents evacuated and transported off-site for disposal. Geotextile fabric base seals and hydrophobic petrochemical sponges are removed and replaced in each chamber. Inlet grates and covers are then re-installed and re-secured with existing locking devices.

Envibro system cleaning utilizes similar maintenance equipment. Servicing includes removal of debris from the trash basket under the collector grate inlet, hydro-vactoring all chambers and cleaning of silt filters. All, inlets, connecting piping and catch basins are cleaned as well with the contents evacuated and transported off-site for disposal. Inspection of the Imbiber Beads® Drain Field assembly is also included in standard maintenance. All hydrophobic absorbents blankets are replaced and inlet grates and covers are re-installed and re-secured with existing locking devices.

Under normal operation, Envibro cleaning is recommended annually or following heavy rainfalls and high loading of the system with foreign trash and debris. Should a spill or other discharge occur, complete service of the systems and replacement of activated Imbiber Beads® Drain Field assembly is normally required.

Below is a list of our Drainage Maintenance services:
Preventative Maintenance
Service Contracts
Drywell Cleaning

Imbiber Beads® is a registered Trademark of Imbibitive Technologies Corporation



"Sun State Builders has had the privilege of working with Torrent Resources for several years. We find their work to be of excellent quality and their customer service is superior. We look forward to utilizing their services in all of our projects in the future."

Andrea Vallas
Assistant Project Manager
Sun State Builders



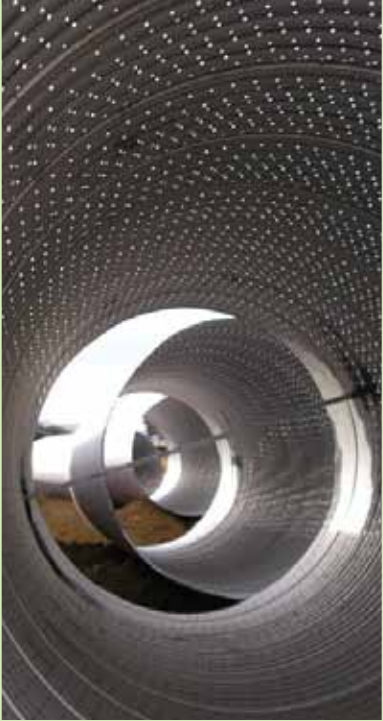

Corrugated Metal Pipe Infiltration System



Stormwater Solutions from Contech



Selecting the Right Stormwater Solution Just Got Easier...

It's simple to choose the right stormwater solution to achieve your goals with the Contech Stormwater Solutions Staircase. First, select the runoff reduction practices that are most appropriate for your site, paying particular attention to pretreatment needs. If the entire design storm cannot be retained, select a treatment best management practice (BMP) for the balance. Finally, select a detention system to address any outstanding downstream erosion.

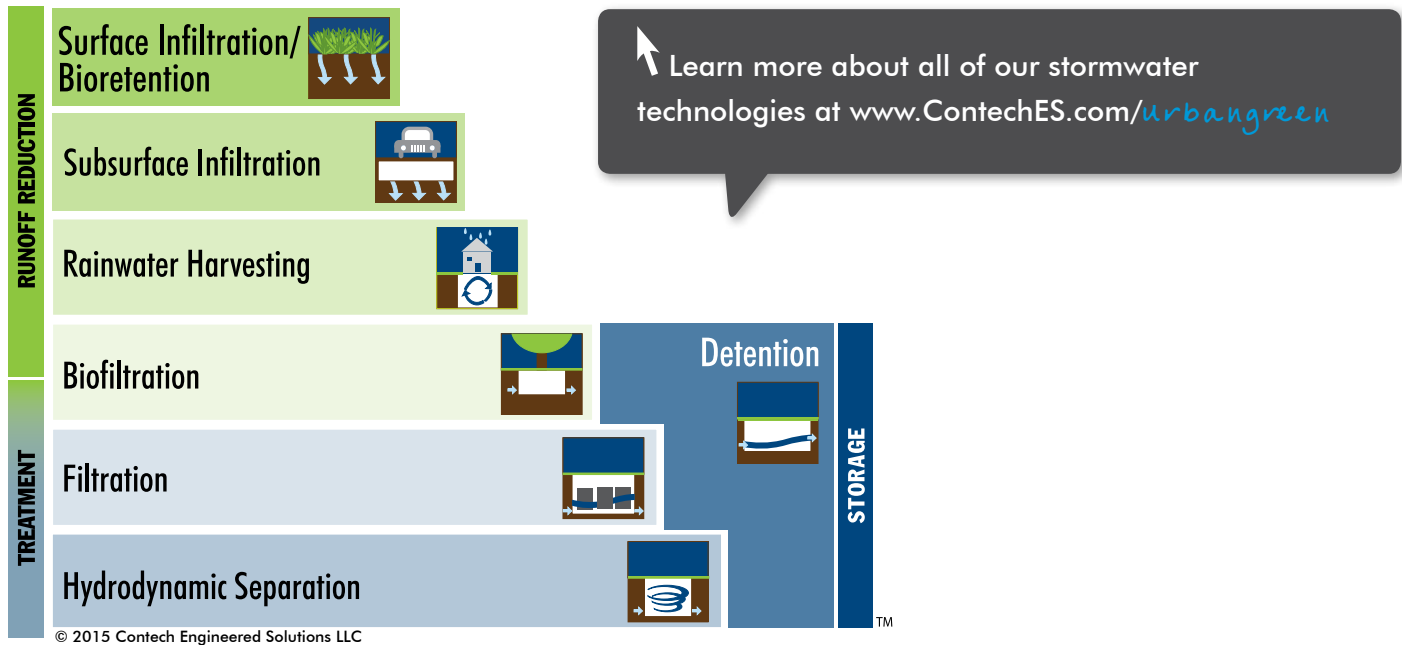

DYODS

DESIGN YOUR OWN DETENTION OR INFILTRATION SYSTEM

The Contech DYODS is an exclusive online design tool that allows users to quickly and easily design their own detention or infiltration system. Just input your required storage volume to calculate the quantity of the material needed for your Contech CMP, CON/SPAN®, or ChamberMaxx® system.

To use the *Design Your Own Detention or Infiltration System* tool, visit: www.ContechES.com/dyods

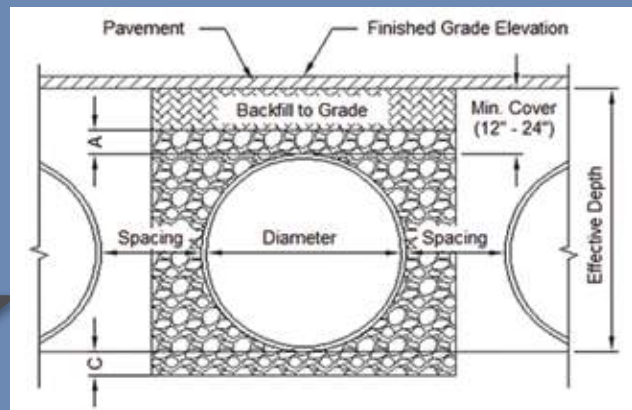

Subsurface Infiltration as a Stormwater Management Strategy

The only sure way to eliminate stormwater pollution is to eliminate stormwater runoff. In recognition of this fact, Green Infrastructure and Low Impact Development based stormwater management regulations prioritizing runoff reduction have proliferated throughout the United States.

Where site conditions allow, infiltration is typically the most cost effective and reliable runoff reduction approach. In urban environments where there are competing demands for land, subsurface infiltration can provide many of the benefits of landscape based systems but without requiring dedicated land area. Infiltration systems are commonly comprised of a pretreatment component designed to remove sediment, trash, and oil, followed by plastic, metal or concrete storage units surrounded by permeable stone creating a high voids storage gallery. Infiltration systems are typically designed to support vehicular loading and to withstand lateral pressures from surrounding soil that allows the overlying land to be used for virtually any non-building application.

Subsurface infiltration meets the objectives of LID by reducing runoff with the added benefit of saving land space in urban environments.



LID benefits include runoff volume reduction, peak flow control, ground water recharge, and water quality improvement.



CMP infiltration is used at Pitzer College in Claremont, California.



CMP – the “Go To” Material for Subsurface Infiltration

The purpose of the storage vessel is to hold stormwater runoff underground while allowing it to infiltrate the surrounding soil. For the majority of applications, corrugated metal pipe (CMP) is the “go to” material for subsurface infiltration.

- A minimum of 75-year service life for most soil/water conditions.
- Various pipe coatings and materials are available to accommodate site-specific needs and extend service life: Aluminized Steel Type 2 (ALT2), Galvanized, CORLIX® Aluminum, and Polymeric.
- Wide range of gages, corrugations, and shapes, in diameters 12” – 144”.
- Pipe can be fully or partially perforated for infiltration, retention, or groundwater recharge applications.
- Custom access risers and manifolds provide direct access for maintenance.
- Outlet control devices can be incorporated within the system, eliminating the need for a separate structure.
- Customizable - a variety of fittings allow CMP to match most layout configurations.
- May be designed for heavy loading and high maximum cover.
- Contributes to LEED points.
- Available locally; quick turnaround time.
- The most economical installed solution.

With its low cost, a wide variety of diameters, layout configurations, and materials, no other material can match CMP’s flexibility and versatility.

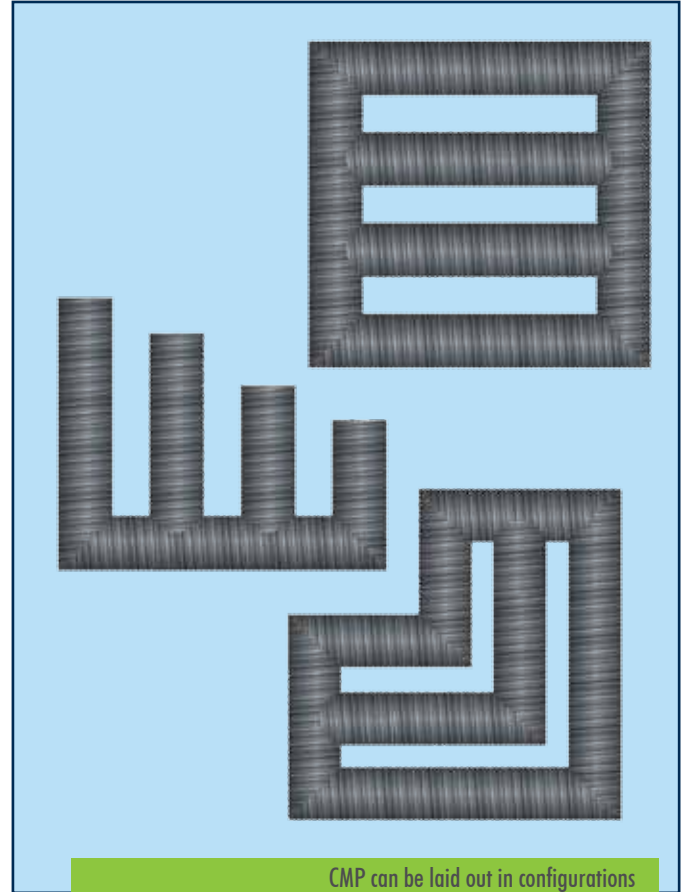

CMP can be laid out in configurations not achievable with other materials.



A wide range of CMP diameters and coatings are available to meet site specific needs.

Addressing the Question of Longevity

Some engineers are hesitant to use corrugated metal pipe (CMP) for stormwater applications because they have read or heard about CMP being used in culverts that have corroded. This shouldn't be the case. Many decades ago, galvanized pipe was the coating of choice for culverts; that now has been replaced with Aluminized Type 2 (ALT2). The primary reason for culvert failure is the galvanized coating was not properly designed to withstand a high flow and abrasive environment, which wears the galvanized coating off the invert of the pipe. The ALT2 is far more abrasive resistant for applications such as culverts and has a wider range for pH and resistivity. Additionally, a detention/infiltration application is not an abrasive environment, so these concerns are further mitigated. Finally, a properly designed infiltration system includes pretreatment and flow control, as well as a stone envelope which prevents interaction with native soils, further reducing the potential for abrasion and corrosion.

- A minimum of 75 year service life for most soil/water conditions and has a proven service life that exceed 100 years with proper specification that meets all AASHTO and ASTM pipe specifications.
- CMP infiltration systems can be designed to meet HS-20 or greater load requirements with proper depths of cover.
- With no abrasion and low flows, coatings remain intact and protect against corrosion inside the pipe that holds stormwater runoff.
- Protective pipe coatings and materials such as ALT2, Galvanized, Polymeric, and CORLIX® Aluminum are matched to the pH and resistivity of the surrounding soil.
- CMP infiltration systems are surrounded by clean crushed rock to provide increased storage capacity. The entire system is wrapped with fabric on the sides and top to prevent the soils from having contact with CMP. Thus, corrosive soils do not come into contact with the pipe.

CMP infiltration systems have a proven service life that exceeds 100-years with proper specification that meets all AASHTO and ASTM pipe specifications.



CMP has a proven service life

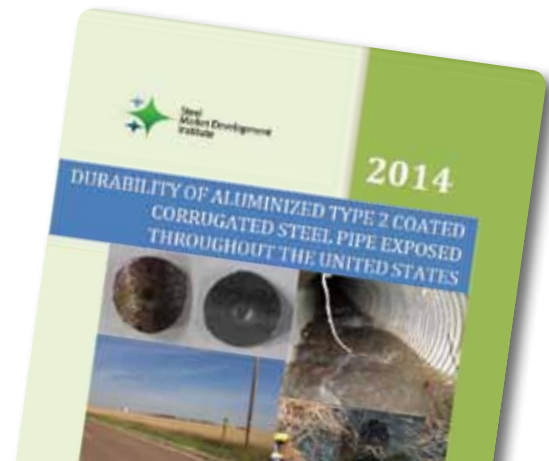

Learn more about the durability of steel through the recent NCSA ALT2 Study - www.ncspa.org



Maximizing Vertical Space: Every Inch Counts

One of the most overlooked advantages of CMP is its ability to maximize vertical storage space.

Increasing the depth of a CMP infiltration system allows for more water storage in the same footprint. For example, doubling the diameter of pipe yields four times as much storage volume in the pipe. This provides a significant cost savings per cubic foot of storage. In addition, more vertical storage space means a smaller footprint, less excavation, and lower project costs.

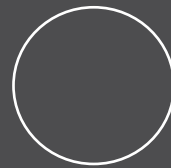

96" diameter - 50.2 ft³/ft



48" diameter - 12.5 ft³/ft

2x the diameter - 4x the storage

Contech's Corrugated Metal Pipe Detention systems maximize vertical storage space.

Sizing

Round Pipe – CMP → 6-in to 144-in

Diameter (inches)	Volume (ft ³ /ft)	Min. Cover Height	Diameter (inches)	Volume (ft ³ /ft)	Min. Cover Height
12	.78	12"	78	33.1	12"
15	1.22	12"	84	38.4	12"
18	1.76	12"	90	44.1	12"
21	2.40	12"	96	50.2	12"
24	3.14	12"	102	56.7	18"
30	4.9	12"	108	63.6	18"
36	7.0	12"	114	70.8	18"
42	9.6	12"	120	78.5	18"
48	12.5	12"	126	86.5	18"
54	15.9	12"	132	95.0	18"
60	19.6	12"	138	103.8	18"
66	23.7	12"	144	113.1	18"
72	28.2	12"			

The Need for Effective Pretreatment

Infiltration systems have multiple components, and one of the most important is pretreatment. The purpose of a pretreatment device is to prolong the life of the infiltration system by removing debris and sediment that can collect on the invert and within the stone backfill voids. Pretreatment will maintain the efficiency of an infiltration system as well as extend the life cycle, therefore preventing a premature replacement. Pretreatment also offers these additional benefits:

- Easier to clean and maintain compared to the infiltration system itself.
- Cost savings due to the extended service life of the system.
- Removing trash and debris protects downstream outlet control structures from clogging.

Pretreatment Design Considerations

When choosing a pretreatment system, it is important to consider the following:

- Downstream outlet control structures may require protection from a pretreatment device that screens trash and debris.
- Pretreatment system selection depends on pollutant targets. Trash, debris, and larger particles can be removed with hydrodynamic separators. Removing high percentages of fine particles and associated heavy metals and nutrients requires filtration.
- Reduced long term maintenance or replacement cost of the infiltration system can help justify pretreatment construction costs.
- Inlet and pipe layout will influence the number and type of pretreatment systems used. A combination of different systems may be appropriate for the various inlet locations and flows.

Pretreatment systems that are easy to maintain and do not rely on the use of geotextile fabric are preferred.

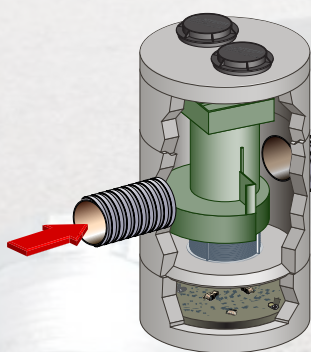

Pretreatment Options

Contech offers a number of pretreatment options, all of which will extend the life of subsurface infiltration systems and improve water quality. The type of system chosen will depend on a number of factors including footprint, soil conditions, local regulations, and the desired level of pretreatment.

CDS provides direct access to cleaning, and the built-in high flow bypass weir eliminates the need for a separate bypass structure.

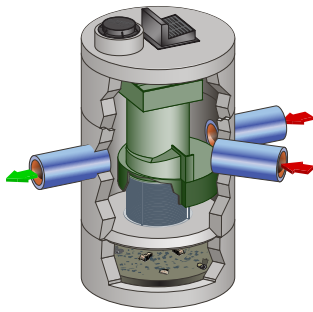

Hydrodynamic Separation

Hydrodynamic Separation (HDS) provides a basic level of pretreatment by capturing and retaining trash and debris, sediment, and oil from stormwater runoff.

CDS®

The CDS uses a combination of swirl concentration and indirect screening and is the only non-blocking screening technology available in an HDS system.



Filtration

Filtration provides a higher level of pretreatment and improved water quality by removing trash and debris, oil, fine solids, and dissolved pollutants such as metals, hydrocarbons, and nutrients.

Filterra® Bioretention System

Filterra is an engineered bioretention system that has been optimized for high volume/flow treatment and high pollutant removal.

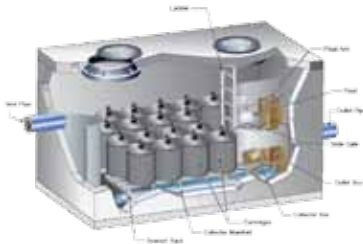

The Stormwater Management StormFilter®

The StormFilter system is comprised of a structure that houses rechargeable, media-filled cartridges. The media can be customized to target site-specific pollutants.



Jellyfish® Filter

The Jellyfish filter uses membrane filtration in a compact footprint to remove a high level and a wide variety of stormwater pollutants such as fine particulates, oil, trash and debris, metals, and nutrients.

Alternative Materials for Subsurface Infiltration

There may be instances where alternative materials are needed for subsurface infiltration due to site specific needs.

Plastic Chambers

Plastic chambers are best suited to shallow depth applications; minimum cover is 18 inches, and maximum cover is 96 inches. Some benefits of chambers are:

- Chambers may be beneficial for sites with limited vertical storage.
- Lightweight and installed by hand.
- Heavy equipment is not required to set units into place.
- Centralized stocking locations for short lead times.

Concrete Structures/Vaults

Some concrete structures and vaults are best suited for high loading applications such as railroads or airports. Concrete units are also ideal in corrosive environments or areas with high salinity. Some benefits of concrete structures are:

- Wide range of spans and heights.
- Greater underground infiltration storage in a smaller footprint.
- Ample and easy maintenance access.
- Fast installation.



Project Profiles: CMP Infiltration Systems in Action

Edie and Lew Wasserman Building, UCLA

Westwood, California

- The new six-story, 100,000 square foot Edie and Lew Wasserman Building was built on a very dense site that needed to meet sustainability requirements.
- The design needed to maximize infiltration volume, match existing inverts, and work around existing utilities.
- The stormwater management systems included a CDS pretreatment system and a CMP infiltration system using 57' of 72" perforated CMP.
- Perforated CMP was selected to avoid utilities, minimize excavation, meet the City of LA LID requirements, contribute to the building's LEED certification, and to provide space for the buildings "outdoor room" and gardens.



Creative Office Space

El Segundo, California

- A stormwater infiltration solution was needed for a new group of office buildings.
- The owner wanted to maximize the use of the parking area in the urban setting.
- The site had a tight footprint and multiple utility constraints, requiring the design of five separate systems.
- A total of 860 LF of perforated CMP was installed providing of 25,265 CF of storage.
- Perforated CMP was selected for its design flexibility, cost effectiveness, and ease of installation.

City Center Regional Stormwater Facility

Mountlake Terrace, Washington

- The city of Mountlake Terrace, Washington needed a new stormwater retention facility to provide stormwater treatment and downstream flood control.
- There was limited footprint for 80,000 CF of runoff, and the system was required to be very deep, with about 15' of cover.
- Engineers designed a system consisting of a CDS pretreatment system in front of 800 linear feet of 120" diameter, perforated, aluminized type 2 CMP that allows the runoff to slowly infiltrate the surrounding soil.
- Perforated CMP was selected for its ability to accommodate the deep bury, the relatively small footprint, and cost effectiveness.



The Right Partner Can Make All the Difference

Regardless of your project's objectives and constraints, our team of stormwater design engineers, regulatory managers, and local stormwater consultants are here to provide you with expert advice and assistance. If your goal is to eliminate or detain runoff, you can rely on Contech for a wide range of subsurface infiltration, detention, and rainwater harvesting solutions. If treatment is needed, our landscape-based biofiltration or subsurface filtration designs can fit into virtually any site and can be tailored to address specific pollutants.

At every stage of your project, count on Contech to provide engineering services including:

- Regulatory guidance and permitting assistance
- Preliminary standard details and/or site specific final CAD drawings and specifications
- Low Impact Development design assistance
- Engineering calculations for hydraulics/hydrology, rainwater harvesting, and detention/retention
- Online "Design Your Own" tools
- Review of preliminary site design, feasibility screening, and layout assistance
- Value engineering – cost estimates and options analysis
- Pre-construction support, project scheduling, and contractor coordination
- Installation and construction support
- Maintenance support:
 - » Guidance manuals
 - » Demonstrations
 - » Qualified contractor identification

The result: an efficient design process, the right product, greater land space savings, and faster permitting. The entire Contech stormwater team welcomes the opportunity to work with you on your stormwater projects.

To get started, please visit www.conteches.com/localresources or call us at 800-338-1122.



Learn more at www.ContechES.com/cmp-detention



Dig Deeper

Find all the information you need at www.ContechES.com, including field and laboratory test results, approvals, brochures, design guides, standard details, and specifications within the product section of our site.

Connect with Us

We're here to make your job easier – and that includes being able to get in touch with us when you need to. Go to www.ContechES.com/ConnectwithContech.

While you're there, be sure to check out our upcoming seminar schedule or request an in-house technical presentation.

Start a Project

If you are ready to begin a project, contact your local representative to get started. Or you can check out our design toolbox for all our online resources at www.ContechES.com/designtoolbox.

Links to Stormwater Tools:

To use the Land Value Calculator, visit:
www.ContechES.com/lvc
(Look under the Stormwater Management section to download the Land Value Calculator)

To use the Design Your Own Detention System tool, visit:
www.ContechES.com/dyods

To use the Design Your Own Hydrodynamic Separator tool, visit: www.ContechES.com/dyohds

To use the Rainwater Harvesting Runoff Reduction Calculator tool, visit: www.ContechES.com/rwh-calculator

To use the LID Site Planner, visit:
www.ContechES.com/LIDsiteplanner



COMPLETE SITE SOLUTIONS

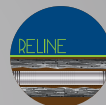
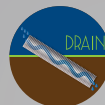

Treatment Solutions

Helping to satisfy stormwater management requirements on land development projects

- Stormwater Treatment
- Detention/Infiltration
- Rainwater Harvesting
- Biofiltration/Bioretenation

Pipe Solutions

Meeting project needs for durability, hydraulics, corrosion resistance, and stiffness

- Corrugated Metal Pipe (CMP)
- Steel Reinforced Polyethylene (SRPE)
- High Density Polyethylene (HDPE)
- Polyvinyl Chloride (PVC)

Structures Solutions

Providing innovative options and support for crossings, culverts, and bridges

- Plate, Precast & Truss bridges
- Hard Armor
- Retaining Walls
- Tunnel Liner Plate

NOTHING IN THIS CATALOG SHOULD BE CONSTRUED AS AN EXPRESSED WARRANTY OR AN IMPLIED WARRANTY OF MERCHANTABILITY OR FITNESS FOR ANY PARTICULAR PURPOSE. SEE THE CONTECH STANDARD CONDITION OF SALES (VIEWABLE AT WWW.CONTECHES.COM/COS) FOR MORE INFORMATION.

Get Social With Us!



CMP Infiltration Bro (5M as of 1/15) PDF 10/15



©2015 Contech Engineered Solutions LLC
800-338-1122 | www.ContechES.com
All Rights Reserved. Printed in the USA.

We print our brochures entirely on Forest Stewardship Council certified paper. FSC certification ensures that the paper in our brochures contain fiber from well-managed and responsibly harvested forests that meet strict environmental and socioeconomic standards.

FSC

AQUA-SWIRL ™

HYDRODYNAMIC SEPARATION

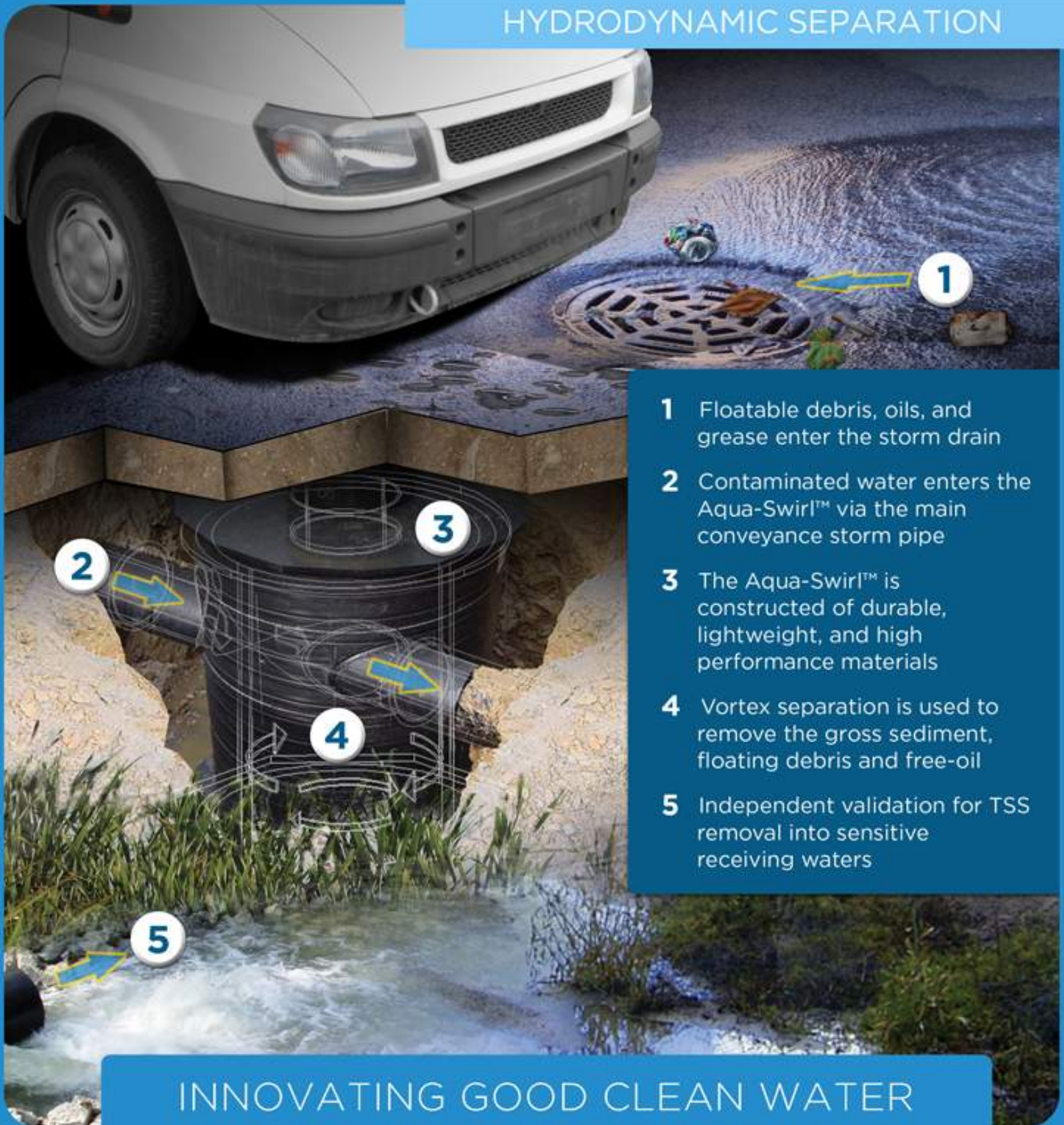

- 1** Floatable debris, oils, and grease enter the storm drain
- 2** Contaminated water enters the Aqua-Swirl™ via the main conveyance storm pipe
- 3** The Aqua-Swirl™ is constructed of durable, lightweight, and high performance materials
- 4** Vortex separation is used to remove the gross sediment, floating debris and free-oil
- 5** Independent validation for TSS removal into sensitive receiving waters

INNOVATING GOOD CLEAN WATER

AQUA-SWIRL

Pipe Connections

- Systems are designed with custom inlet / outlet diameters at various configuration angles
- Inlet / outlet stubouts are provided for easy coupling

Inspection & Maintenance

- AquaShield™ offers an extensive maintenance program that ensures system performance efficiency
- Download manuals from the on-line system catalog

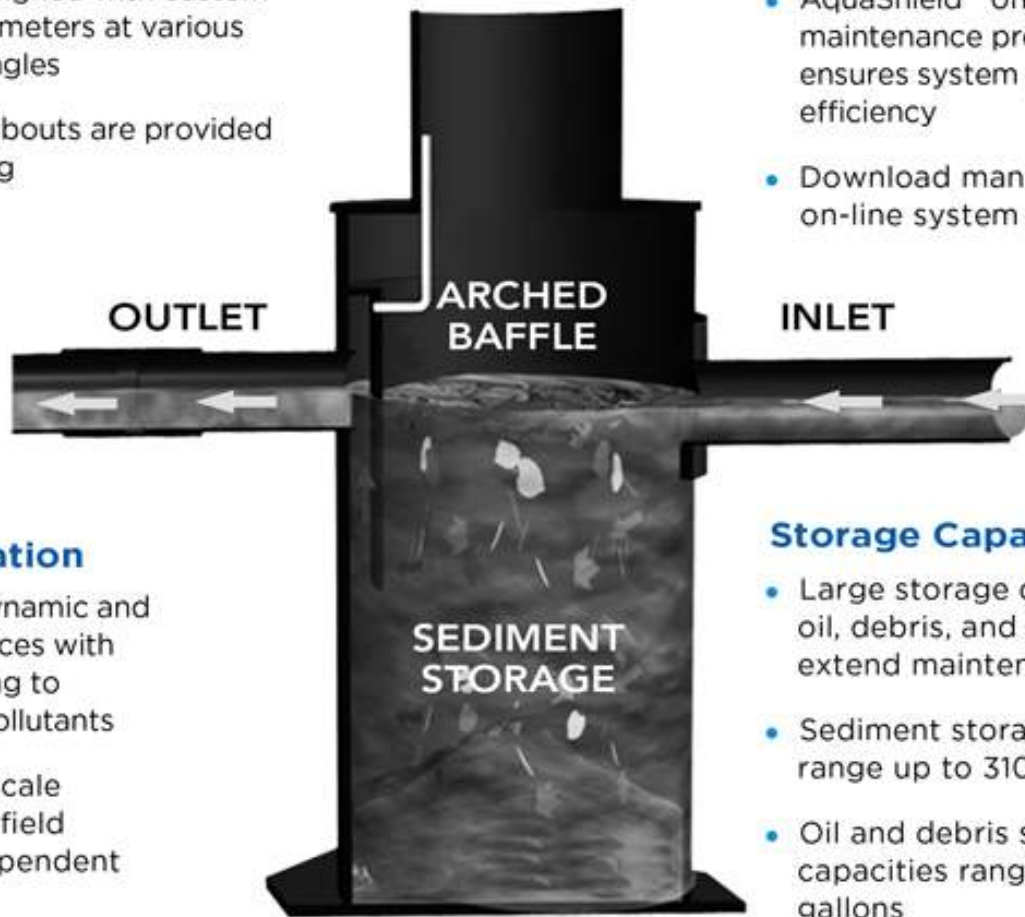

Vortex Separation

- Utilizes hydrodynamic and gravitational forces with quiescent settling to remove gross pollutants
- Extensive full-scale laboratory and field testing by independent third parties

Storage Capacities

- Large storage capacities for oil, debris, and sediment extend maintenance cycles
- Sediment storage capacities range up to 310 ft³
- Oil and debris storage capacities range up to 1986 gallons

Bypass

- Systems are designed to treat water quality flow rates and bypass peak storm events
- Internal and external bypass configurations are available

Installation Benefits

- Quick and simple installation, resulting in measurable project cost savings
- H₂O loading capabilities
- Small footprint design reduces excavation costs
- Lightweight and durable construction
- Lifting supports & cables provided

Aqua-Swirl™ System

- Provides customized solutions for project specific requirements
- Systems designed for specific water quality treatment flows
- Modular sizes from 2.5 - 13 ft diameters with attached risers to finish grade
- On-line project and system design tool at <http://pda.aquashieldinc.com>

STATEMENT OF QUALIFICATIONS

AQUA-SWIRL[®] STORMWATER TREATMENT SYSTEM



January 2017



AquaShield[™], Inc.
2733 Kanasita Drive
Suite 111
Chattanooga, Tennessee 37343
(888) 344-9044
Fax (423) 826-2112
www.aquashieldinc.com

Aqua-Swirl® Statement of Qualifications

Table of Contents

	<u>Page</u>
1.0 Overview	1
1.1 Mode of Operation	1
1.2 General Equipment Design	2
1.3 Range of Operating Conditions	3
1.4 Contaminants to be Treated	3
1.5 Inspection and Maintenance	4
2.0 Construction Materials	5
3.0 Use Applications	5
4.0 Performance Testing	5
4.1 Laboratory Testing	6
4.2 Field Testing	6
5.0 Regulatory Approvals	7
5.1 States and Provinces	8
5.2 State Departments of Transportation	9
5.3 Regional Planning Authorities	9
5.4 Counties	9
5.5 Municipalities	10
6.0 Limited Warranty	10

AQUA-SWIRL® STATEMENT OF QUALIFICATIONS

1.0 OVERVIEW

1.1 Mode of Operation

The Aqua-Swirl® Stormwater Treatment System (Aqua-Swirl®) is a custom engineered, post-construction flow-through structure designed to remove sediment, floating debris, trash and free-floating oil by utilizing hydrodynamic vortex-enhanced separation (Figure 1). The United States patent, “Drainwater Treatment System for Use in a Horizontal Passageway,” U.S. Patent No. 6,190,545 currently applies to the Aqua-Swirl®.

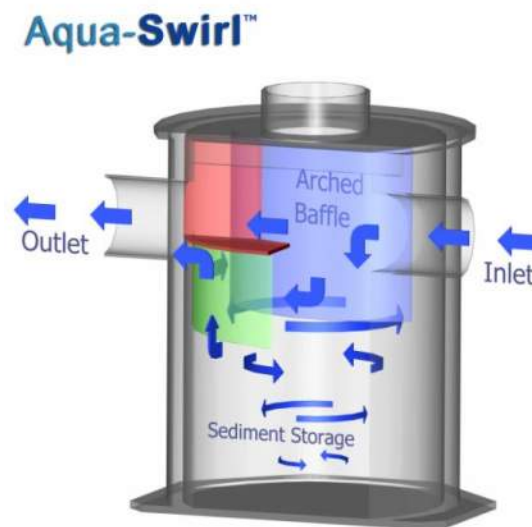

Figure 1. Diagram of Aqua-Swirl® Stormwater Treatment System showing the circular flow of water through the system which encourages settling of sediment and retention of floatable materials.

Aqua-Swirl® technology is a rapid or high flow rate device that has no moving parts and operates on gravity flow or movement of the stormwater runoff entering the structure. Operation begins when stormwater enters the Aqua-Swirl® by means of its tangential inlet pipe thereby inducing a circular (swirl or vortex) flow pattern. The diameter of the swirl chamber represents the effective treatment area of the device. Both sediment capture and sediment storage is accomplished within the swirl chamber. A combination of gravitational and hydrodynamic drag forces results in solids dropping out of the flow and migrating to the center of the swirl chamber where velocities are the lowest. Flow circulates downward where water exits the swirl chamber by flowing underneath and upward behind the arched inner baffle. The top of the baffle is sealed across the treatment channel to eliminate floatable pollutants from escaping the swirl chamber. A vent pipe is extended up the riser to expose the backside of the baffle to atmospheric conditions, thus preventing a siphon from forming at the bottom of the baffle. Sediment is stored at the base of the swirl chamber while floatables remain captured with the treatment area.

1.2 General Equipment Design

A unique quality of the Aqua-Swirl® is its modular design which allows for faster and simpler installation on new construction or retrofit projects for existing storm drainage structures. The Aqua-Swirl® can operate in either an offline or online configuration. Offline designs rely on the use of a separate external bypass structures. The diversion structure directs only the designed water quality treatment flow (WQ_f) to the unit whereby flows in excess of the WQ_f bypass the Aqua-Swirl®. Online Aqua-Swirl® systems utilize an internal bypass design (models designated as “BYP”) to allow for the conveyance of both the WQ_f and the bypass flow volumes. Aqua-Swirl® systems provide for equal invert elevations for both the inlet and outlet pipe stubouts. No external driving head is needed for operation other than that needed to convey flow according to the site design.

The diameter of the swirl chamber’s treatment area varies from 2.5 to 13 feet depending on model size necessary to treat the WQ_f. Table 1 summarizes the available Aqua-Swirl® models, swirl chamber inner diameters, and oil/debris and sediment storage capacities.

Table 1. Aqua-Swirl® Models and Storage Capacities

Aqua-Swirl® Model	Swirl Chamber Inner Diameter (ft)	Water Quality Treatment Flow Rates (cfs)	Oil/Debris Storage Capacity (gal)	Sediment Storage Capacity (ft³)
AS-2	2.5	1.1	37	10
AS-3	3.3	1.8	110	20
AS-4	4.3	3.2	190	32
AS-5	5.0	4.4	270	45
AS-6	6.0	6.3	390	65
AS-7	7.0	8.6	540	90
AS-8	8.0	11.2	710	115
AS-9	9.0	14.2	910	145
AS-10	10.0	17.5	1,130	180
AS-11	11.0	21.2	1,422	222
AS-12	12.0	25.2	1,698	270
AS-13	13.0	29.6	1,986	310
AS-XX		Custom*		

* Custom designs to meet site-specific criteria, can include multiple (twin) units for increased flow and materials storage capacity.

The Aqua-Swirl® is also designed so that it can easily be used for retrofit applications. When the invert of the inlet and outlet pipe of the Aqua-Swirl® is positioned at the same elevation the unit can easily be connected directly to the existing storm conveyance drainage system.

Shop drawings and any other pertinent design drawings are provided on a site-specific basis. Additional information on custom designs and detail drawings can be provided on request for each of the construction materials available for the Aqua-Swirl® (see Section 2.0 construction materials). Given that Aqua-Swirl® systems can be custom designed, a number of offline configurations can be utilized. AquaShield™ can assist with facility layouts to minimize an Aqua-Swirl® footprint.

The Aqua-Swirl® has been designed and fabricated as a modular unit with no moving parts or on-site assembly required. Since the system is fabricated from high performance, lightweight and durable construction materials, the device can be installed without the use of a crane. Lifting supports are provided to allow easy offloading and installation with a backhoe or trackhoe. In addition, manufactured stubouts for the inlet and outlet piping are provided which allows the installer to simply attach the Aqua-Swirl® directly to the main conveyance storm pipe with Fernco™ or equivalent couplings. Pick weights are available on request.

All Aqua-Swirl® systems are supplied with octagonal base plates which typically extend a minimum of six inches beyond the outside diameter of the swirl chamber. The function of the base plate extension is to provide additional surface area to counter any buoyant force exerted on the system. The forces created on the base plate by the weight of the surrounding fill material offsets the buoyant force generated within the system. If needed, concrete can be poured directly onto the base plate to provide additional resistive force. AquaShield™ routinely performs buoyancy calculations for all system installations.

1.3 Range of Operating Conditions

Aqua-Swirl® systems have been designed to provide water quality treatment at a range of flow rates. AquaShield™ actively assists design engineers to properly size a system to meet site-specific water quality design storm. It is important to consider that when two identical Aqua-Swirl® units are installed in parallel the operating range can double from that of a single unit such that exceptionally large flow rates can be effectively treated.

1.4 Contaminants to be Treated

The primary waterborne contaminants of concern to be treated by the Aqua-Swirl® include:

- Suspended Sediment (commonly referred to as Total Suspended Solids, TSS)
- Trash/Debris
- Free-floating oil

The quantities of the COCs to be treated are based on site-specific pollutant loading factors. While the Aqua-Swirl® is not specifically designed to function in lieu of an oil-water separator, the device still provides treatment against free floating oil when conditions allow.

1.5 Inspection and Maintenance

A comprehensive Aqua-Swirl® Inspection and Maintenance Manual is provided for each site delivery for end users to understand system operations and track and document system inspection and maintenance cycles. AquaShield™ recommends that periodic Aqua-Swirl® system inspections be performed to determine whether the disposal of captured material is needed to ensure proper operation of the treatment system. It is important to keep in mind that *all* stormwater control measures (SCMs), including manufactured treatment devices (MTDs), require some degree of maintenance. Maintenance cycles are ultimately dependent on site-specific pollutant loading conditions.

Upon installation and during construction, AquaShield™ recommends that an Aqua-Swirl® treatment system be inspected every three months and the system be cleaned as needed. A typical maintenance event for the cleaning of the swirl chamber can be accomplished with a vacuum truck without the need to enter the chamber. The Aqua-Swirl® should be inspected and cleaned at the end of construction regardless of whether it has reached its capacity for sediment or oil storage. During the first year post-construction, the Aqua-Swirl® should again be inspected every three months and cleaned as needed. AquaShield™ recommends that the system be inspected and cleaned once annually regardless of whether it has reached its sediment or floatable pollutant storage capacity. For the second and subsequent years post-construction, the Aqua-Swirl® can be inspected and cleaned once annually if the system did not reach full sediment or floatable pollutant capacity in the first year post-construction. If the Aqua-Swirl® reached full sediment or floatable pollutant capacity in less than 12 months in the first year post-construction, the system should be inspected once every six months and cleaned as needed. AquaShield™ further recommends that all external bypass structures (divergent and convergent) should be inspected whenever an inspection and maintenance event is performed. These structures can adversely affect performance and functionality if left unchecked.

Essential elements of a swirl chamber inspection include observing floating materials and measuring the accumulated sediment at the base of the swirl chamber. These two activities can be performed at the ground surface (for a typical subsurface installation) and there is no need to enter the device. Provided that there are no significant access restrictions to the facility, it is considered that a system inspection should not exceed one half hour. A typical maintenance event includes the vacuuming and disposal of floatable pollutants and sediment from the swirl concentrator. Cleaning of the swirl chamber is often accomplished by use of a vacuum truck. It is estimated that the on-site activities for maintenance should not exceed one hour and can be performed by a one or two man crew. AquaShield™ recommends that if entry to the swirl chamber is necessary for any reason, then confined space entry techniques should be followed.

Proper health and safety protocols should be followed during all inspection and maintenance events. AquaShield™ recommends that all materials removed during the maintenance process be handled and disposed in accordance with all applicable federal, state and local guidelines. Depending on the influent pollutant characteristics of the system drainage area, it may be appropriate to perform Toxicity Characteristics Leaching Procedure (TCLP) analyses on representative samples of the removed material to ensure that the handling and disposition of materials complies with all applicable environmental regulations.

2.0 CONSTRUCTION MATERIALS

The Aqua-Swirl® is available using construction materials of either High Density Polyethylene (HDPE) or Polymer Coated Steel (PCS). Unique site conditions may require deviations to standard installation specifications. It is recommended that AquaShield™ be contacted prior to extraordinary installations to determine the extent to which any deviation, if possible, can be made to ensure that the integrity, functionality and product warranty of the device is maintained. Both HDPE and PCS provide high structural integrity for both long term durability and traffic loading conditions. Material specifications can be provided on request.

3.0 USE APPLICATIONS

Aqua-Swirl® technology can be applied to a wide variety of land uses and facilities. Common system applications include, but are not limited to, the following types of settings:

- Retail/Commercial Developments
- New and Existing Industrial Facilities
- Highway Construction
- Transportation facilities
- Watershed Protection
- Redevelopment/Retrofit Sites
- Government Facilities
- Military Installations, Bases and Berthing Wharfs
- Vehicle and Equipment Wash Rack Areas
- Fueling Centers and Convenience Stores
- Fast Food Restaurants
- Office Complexes
- Religious Centers
- Educational Facilities
- Residential Developments (single and multi-family)
- Coastal Zone Management Communities
- Drinking Water Well-head Protection Areas

Thousands of Aqua-Swirl® systems have been installed throughout the United States including the Commonwealth of Puerto Rico and the Territory of Guam. Aqua-Swirl® systems are also installed in Brazil, Canada, Hong Kong, India, the Middle East, Russia, South Korea and United Kingdom. Climatic conditions for Aqua-Swirl® installations range anywhere from sub-arctic (e.g., central Alaska) to sub-tropical locales. Information concerning domestic and international projects can be provided on request.

4.0 PERFORMANCE TESTING

The Aqua-Swirl® has completed comprehensive, independent full scale model testing in both laboratory and field settings. Summaries of both testing programs are provided in the following two sections.

4.1 Laboratory Testing

Independent performance testing of an Aqua-Swirl® Model AS-3 was conducted by the Department of Civil and Environmental Engineering at Tennessee Tech University (TTU), Cookeville and is described in the findings report, *Laboratory Evaluation of TSS Removal Efficiency for Aqua-Swirl® Concentrator Stormwater Treatment System*. The test parameters included loading rates, sediment concentrations, specific gravity, head loss, and particle size distribution. The test sediment was OK-110 manufactured by U.S. Silica, having a specific gravity of 2.65. The test material has a particle size range of approximately 50 to 150 microns (μm), representing the finest fraction of sand particulate. The test sediment manufacturer reports a median (d_{50}) particle size of 110 μm . However, other independent laboratory-specific testing programs performed in association with Aqua-Swirl® product development actually demonstrated a d_{50} of 90 to 95 μm . Note that OK-110 is no longer manufactured due to the manufacturer's inability to consistently meet the product specification.

Total suspended solids (TSS) concentrations were determined by the Suspended Sediment Concentration (SSC) analytical method consistent with ASTM D3977. The SSC method differs from the commonly cited TSS analytical method, EPA 2540D (formerly EPA 160.2) such that the SSC analysis is a whole sample TSS procedure. The analytical results of influent and effluent sample pair concentrations were used to calculate SSC removal efficiencies for each run at the target loading rates and concentrations. This study concluded that Aqua-Swirl® achieves an SSC removal efficiency of 91% on a net annual basis.

The results of this laboratory testing program have been independently verified by the New Jersey Corporation for Advanced Technology (NJCAT). The Washington State Department of Ecology has also assigned the General Use Level Designation (GULD) for Pretreatment (TSS) for the Aqua-Swirl®.

4.2 Field Testing

An Aqua-Swirl® Model AS-5 completed a 27 month independent field testing program in accordance with the Technology Acceptance Reciprocity Partnership (TARP) Tier II Field Testing Protocol. A total of 18 storms and 15.16 inches of rain were sampled between March 2009 and June 2011, demonstrating that the Aqua-Swirl® achieved 86% and 87% TSS and SSC removal efficiency, respectively. AECOM of Philadelphia, Pennsylvania served as the independent field testing organization. The test site is an asphalt covered parking lot with landscaped areas at the urban retail center in Silver Spring, Maryland (metro Washington D.C.). All samples were collected using ISCO autosamplers positioned at the influent and effluent pipe connections. ISCO area-velocity modules were used to gauge influent and effluent flow conditions. Suspended sediment analyses were performed by both the TSS and SSC Methods as cited above. Particle size distribution (PSD) was determined by serial filtration. Average influent PSD data indicates that 86% of the particulate is $<125 \mu\text{m}$ and 72% of the particulate is silt (1.5 to 63 μm). The test site particulate is classified as a clay loam textured sediment. The target NJDEP PSD is to exhibit a particulate range of 1.0 to 1,000 μm and a d_{50} of 67 μm . Figure 1 illustrates the influent PSD curve for the AS-5 and includes the NJDEP PSD standard. All field test analyses were performed by Test America, Inc. of Burlington, Vermont, a NELAP and New Jersey certified facility.

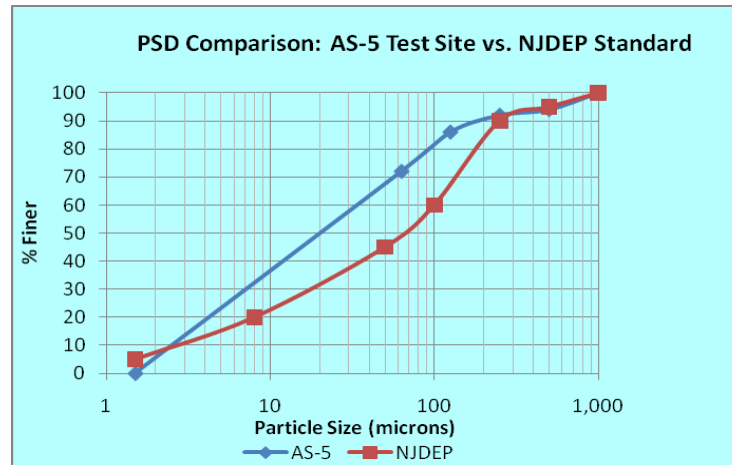

Figure 2. Particle size distribution for AS-5 Field test versus NJDEP laboratory test sediment particulate distribution.

Table 2 summarizes TSS and SSC removal efficiencies, storm durations, storm sizes, peak intensities, peak loading rates and percentage TVSS of TSS. Cumulative average sediment removal efficiencies for TSS and SSC are 86 and 87%, respectively. Cumulative average influent TSS and SSC concentrations are 132 and 145 mg/L, respectively. Storm sizes range from 0.11 to 4.4 inches with storm intensities ranging from 0.15 to 5.49 in/hr. Influent loading rates range from 1.9 to 35.4 gpm/ft².

The AS-5 field testing results have also been independently verified by NJCAT to achieve 86% TSS removal on an annual basis, consistent with the laboratory findings. The Washington State Department of Ecology subsequently issued Conditional Use Level Designation (CULD) for the Aqua-Swirl® based on the results of the AS-5 field test.

5.0 REGULATORY APPROVALS

The approval lists included herein are not intended to represent all Aqua-Swirl® approvals or installation locations. Instead, the listings represent regulatory agencies that have some recognized measure of technology review in association with their local approval process for manufactured stormwater treatment devices (MTDs). Given that there are a number of scenarios that can be followed in order to gain a regulatory approval, the lists included below provide a high level of credibility toward the approval of the Aqua-Swirl® in a variety of regional and regulatory diverse settings. Additional information can be provided regarding regulatory approvals and installation locales.

Table 2. Summary of Sediment Removal Efficiency and Storm Characteristics

#	Sample Date	TSS RE (%)	SSC RE (%)	Storm Duration (hr:min)	Storm Size (in)	Peak Storm Intensity (in/hr)	Peak Loading Rate (gpm/ft ²)	% TVSS of TSS
1	3/14/2009	98.3	99.3	0:30	0.11	0.26	4.1	NA
2	4/1/2009	86.8	82.7	0:50	0.18	0.46	8.1	NA
3	4/6/2009	82.5	85.5	2:00	0.15	0.26	4.8	NA
4	12/25-26/2009	99.0	99.5	11:45	0.56	0.38	4.8	NA
5	1/17/2010	94.8	96.3	4:48	0.59	0.42	10.4	NA
6	7/25/2010	94.1	96.5	0:46	0.55	1.21	16.9	38.8
7	8/12/2010	63.9	68.0	3:00	1.82	5.49	30.9	22.3
8	9/12/2010	96.5	96.6	3:45	0.61	0.49	13.1	31.0
9	9/29-30/2010	59.9	57.4	12:05	4.40	2.56	35.4	20.9
10	12/1/2010	89.1	86.9	6:20	0.71	1.82	4.1	16.7
11	12/11/2010	96.1	97.7	3:40	0.72	0.58	2.3	29.2
12	2/25/2011	73.0	72.8	2:15	0.29	0.25	4.1	29.0
13	3/6/2011	86.1	92.5	4:50	1.42	0.46	11.0	25.4
14	3/15-16/2011	88.1	91.7	5:06	0.42	0.35	1.9	24.4
15	4/8/2011	94.1	95.8	3:55	0.52	0.15	3.4	25.2
16	4/28/2011	80.4	82.0	2:19	0.23	0.23	12.5	71.4
17	5/14/2011	90.6	90.3	3:05	0.85	0.47	5.7	48.9
18	6/16/2011	74.3	82.7	3:20	1.03	0.91	13.1	48.9
	Average	86.0	87.3		0.84	0.93	10.4	33.2
				Total	15.16			

5.1 States and Provinces

The following states and Ontario are recognized to issue use level designation for MTDs. Both NJDEP and Washington State administer the most widely recognized stormwater management programs throughout the U.S.

State / Province	Agency	Aqua-Swirl® Approval Status
New Jersey	Department of Environmental Protection	Field Test Certification
		Laboratory Test Certification
Washington	Department of Ecology	General Use Level Designation for Pretreatment (TSS)
		Conditional Use Level Designation for Basic (TSS) Treatment
Maryland	Department of the Environment	Approved
Virginia	Department of Environmental Quality	Approved (Total Phosphorus 20%)
Wisconsin	Department of Commerce.	Approved
Ontario	Ministry of the Environment	Certificate of Technology Assessment

5.2 State Departments of Transportation

Several states utilize their respective Departments of Transportation as a regulatory agency to administer the MTD approval process. These approvals can include use level designations specific to highway projects and can extend to most other installation applications for which MTD technologies can be utilized. It should also be kept in mind that a number of local jurisdictions also rely on their state's DOT for MTD approvals. The table below lists state DOTs that have approved the Aqua-Swirl®.

State DOT	Aqua-Swirl® Designation
California	Approved
Michigan	Approved
New Jersey	Approved
North Carolina	Provisional Use
Ohio	Qualified Products List
Rhode Island	Approved
Texas	Approved
Utah	Approved

5.3 Regional Planning Authorities / Water Use Districts

The Aqua-Swirl® maintains several approvals at the regional planning authority or water use district levels such that municipalities within those jurisdictions typically adopt these MTD approvals. Examples of such jurisdictional approvals for which the Aqua-Swirl® are cited below.

Jurisdiction	Example Municipality(s)
Northwest Florida Water Mgmt. District	Tallahassee
Nashville, TN Metro Water Services	Nashville, Brentwood, Franklin
Puerto Rico Electric Power Authority	Island
St. Louis, MO Metro Sewer District	St. Louis and surrounding municipalities, Missouri
Tahoe Regional Planning Agency	Lake Tahoe Basin, Nevada and California

5.4 Counties

Aqua-Swirl® approvals have also been issued through several counties that administer stormwater management programs that include an MTD approval process. These approvals may be implemented such that an MTD can be installed at locations only outside of an incorporated municipality in that county (e.g., Montgomery County). Or, the county approval can be used such that an Aqua-Swirl® can be installed at any location within the county (e.g., Whitfield County). The Aqua-Swirl® is approved at the following county levels:

County	State	Example Municipality(s) w/in County
Ada, Highway District	Idaho	Boise
Hamilton	Tennessee	Chattanooga
Knox	Tennessee	Knoxville
Los Angeles	California	Greater Los Angeles area
Montgomery	Maryland	Unincorporated areas
San Diego	California	San Diego
Whitfield	Georgia	Dalton

5.5 Municipalities

A representative list of municipalities that have required some degree of Aqua-Swirl® evaluation and approval is provided below. It should again be kept in mind that this list does not include every locale where either approvals or installations have occurred.

State / Province	Municipality	State / Province	Municipality
Alabama	Mobile	North Carolina	Hendersonville
California	Santa Monica	Ontario	Hamilton
	Stockton		Oshawa
Georgia	Alpharetta		Ottawa
Hawaii	Honolulu		Simcoe
Idaho	Boise		Toronto (pending)
	Caldwell	Oregon	Eugene
	Meridian	Prineville	
Indiana	Auburn	Quebec	Montréal
	Fishers		Port de Tois-Rivières
	Indianapolis		Quebec City
Maryland	Rockville		Lac Mégantic
	Bethesda	Tennessee	Chattanooga
	Laurel	Knoxville	
	Waldorf	Murfreesboro	
Michigan	Farmington Hills	Utah	Salt Lake City
	Fenton		South Jordan
	Novi		Vernal
Montana	Billings	Washington (Eastern)	Spokane
	Bozeman	Washington D.C.	District of Columbia
	Butte	Wyoming	Jackson Hole

6.0 LIMITED WARRANTY

An Aqua-Swirl® one year limited warranty comes standard with each device and covers against failure due to improper workmanship or defective materials for one year from delivery date. Liability limitations are described in the warranty which is available on request.

Table 17. BMP Performance – Influent/Effluent Water Quality.

BMP	Sediment (mg/L)	Nitrogen (mg/L)	Phosphorus (mg/L)	Metals – Zn (µg/L)	Oil and Grease (mg/L)	Bacteria (#/100mL)	Temp	Notes
Bioretention without underdrain	0	0	0	0	0	0	Excellent	Infiltration practices are assumed to have zero discharge
Bioretention with underdrain	34/15.5*	1.68/1.14†	0.61/0.16*	107/46*	30.8/2.5†	641.5/86.5§	Moderate*	
Permeable Pavement without underdrain	0	0	0	0	0	0	Excellent	Infiltration practices are assumed to have zero discharge
Permeable Pavement with underdrain	xx/17.0††	xx/1.23††	xx/0.09††	xx/17††	xx/0.018††	No data	Moderate	
Capture and Reuse	0	0	0	0	0	0	Excellent	Infiltration practices are assumed to have zero discharge
Vegetated Roofs	No data	1.3/1.63***	0.012/0.057***	No data	N/A	xx/22§	Moderate	
Downspout Disconnection	0	0	0	0	0	0	Excellent	Infiltration practices are assumed to have zero discharge
Soil Amendments	0	0	0	0	0	0	Excellent	Infiltration practices are assumed to have zero discharge
Vegetated Filter Strips	114/27.6§§	1.12/0.66††	0.38/0.86§§	355/79§§	No data	No data	Low	
Vegetated Swales	114/58.9§§	No data	0.38/0.62§§	355/96§§	No data	13,492/5,947 ^s	Low	
Infiltration Basins	0	0	0	0	0	0	Excellent	Infiltration practices are assumed to have zero discharge
Infiltration Trenches	0	0	0	0	0	0	Excellent	Infiltration practices are assumed to have zero discharge

Source: Data assembled by the Low Impact Development Center, Inc.

Table 17 (Cont.): BMP Performance – Influent/Effluent Water Quality.

BMP	Sediment (mg/L)	Nitrogen (mg/L)	Phosphorus (mg/L)	Metals – Zn (µg/L)	Oil and Grease (mg/L)	Bacteria (#/100mL)	Temp	Notes
Dry Wells	0	0	0	0	0	0	Excellent	Infiltration practices are assumed to have zero discharge
Dry Ponds	114/46.6 ^{ss}	0.96/0.98 ^{††}	0.38/0.28 ^{ss}	355/136 ^{ss}	2.72/2.54 ^{††}	2,218/1,741 ^s	Poor	
Constructed Wetlands	37.8/17.8 ^{††}	2.12/1.15 ^{††}	0.27/0.14 ^{††}	47/31 ^{††}	No data	2,097/257 ^s	Poor ^{**}	
Wet Ponds	114/11.8 ^{ss}	2.29/1.46 ^{††}	0.38/0.54 ^{ss}	355/37 ^{ss}	0.82/0.88 ^{††}	2,693/446.4 ^s	Poor ^{**}	
Media Filters / Filter Basins	114/11.3 ^{ss}	No data	0.38/0.25 ^{ss}	355/36 ^{ss}	No data	1,820/541.3 ^s	Poor	Includes Austin sand filter, Delaware sand filter, Multi-chambered treatment trains
Proprietary Devices	varies	varies	varies	varies	varies	varies	Poor	Performance is device-specific
Key:	^s Clary et al, 2008	[†] Hunt et al, 2008	^{††} Hunt et al, 2008	^{†††} Hong et al, 2006	^{††††} Teemusk and Mander, 2007			
	^{**} Jones and Hunt, 2008	^{ss} Caltrans, 2004	^{††††} Geosyntec, 2008	^{†††††} International Stormwater BMP Database, 2009				

Source: Data assembled by the Low Impact Development Center, Inc.

Appendix 7: Hydromodification

Supporting Detail Relating to Hydrologic Conditions of Concern

HCOC Applicability Map

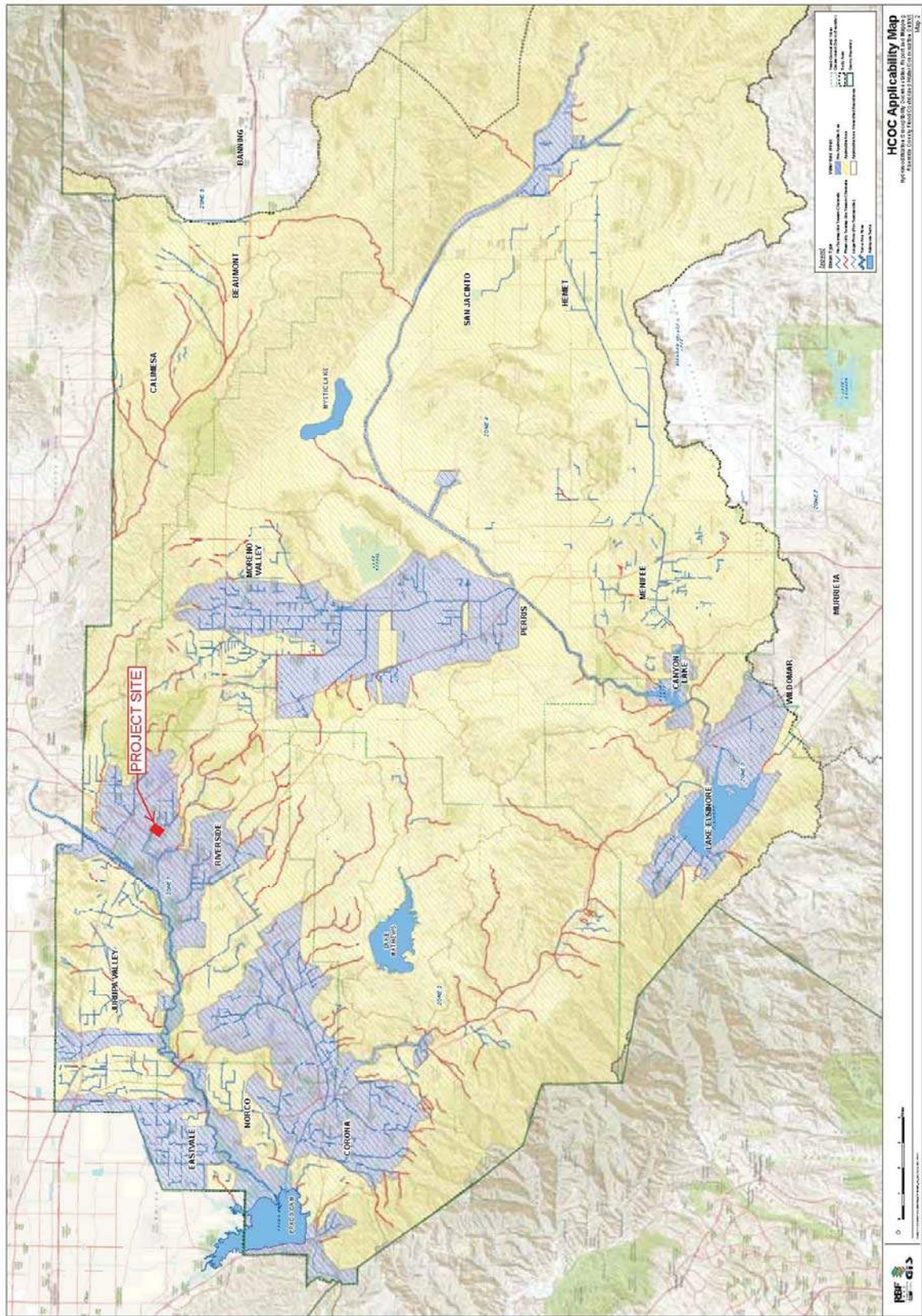

Appendix 8: Source Control

Pollutant Sources/Source Control Checklist

STORMWATER POLLUTANT SOURCES / SOURCE CONTROL CHECKLIST

How to use this worksheet (also see instructions in Section G of the WQMP Template):

1. Review Column 1 and identify which of these potential sources of stormwater pollutants apply to your site. Check each box that applies.
2. Review Column 2 and incorporate all of the corresponding applicable BMPs in your WQMP Exhibit.
3. Review Columns 3 and 4 and incorporate all of the corresponding applicable permanent controls and operational BMPs in your WQMP. Use the format shown in Table G.1 on page 23 of this WQMP Template. Describe your specific BMPs in an accompanying narrative, and explain any special conditions or situations that required omitting BMPs or substituting alternative BMPs for those shown here.

... THEN YOUR WQMP SHOULD INCLUDE THESE SOURCE CONTROL BMPs, AS APPLICABLE			
1	2	3	4
Potential Sources of Runoff Pollutants	Permanent Controls—Show on WQMP Drawings	Permanent Controls—List in WQMP Table and Narrative	Operational BMPs—Include in WQMP Table and Narrative
<input checked="" type="checkbox"/> A. On-site storm drain inlets	<input checked="" type="checkbox"/> Locations of inlets.	<input checked="" type="checkbox"/> Mark all inlets with the words "Only Rain Down the Storm Drain" or similar. Catch Basin Markers may be available from the Riverside County Flood Control and Water Conservation District, call 951.955.1200 to verify.	<input checked="" type="checkbox"/> Maintain and periodically repaint or replace inlet markings. <input checked="" type="checkbox"/> Provide stormwater pollution prevention information to new site owners, lessees, or operators. <input checked="" type="checkbox"/> See applicable operational BMPs in Fact Sheet SC-44, "Drainage System Maintenance," in the CASQA Stormwater Quality Handbooks at www.cabmphandbooks.com <input type="checkbox"/> Include the following in lease agreements: "Tenant shall not allow anyone to discharge anything to storm drains or to store or deposit materials so as to create a potential discharge to storm drains."
<input type="checkbox"/> B. Interior floor drains and elevator shaft sump pumps <input type="checkbox"/> C. Interior parking garages		<input type="checkbox"/> State that interior floor drains and elevator shaft sump pumps will be plumbed to sanitary sewer. <input type="checkbox"/> State that parking garage floor drains will be plumbed to the sanitary sewer.	<input type="checkbox"/> Inspect and maintain drains to prevent blockages and overflow. <input type="checkbox"/> Inspect and maintain drains to prevent blockages and overflow.

STORMWATER POLLUTANT SOURCES / SOURCE CONTROL CHECKLIST

<p align="center">1</p> <p align="center">IF THESE SOURCES WILL BE ON THE PROJECT SITE ...</p>	<p align="center">2</p> <p align="center">Permanent Controls—Show on WQMP Drawings</p>	<p align="center">3</p> <p align="center">Permanent Controls—List in WQMP Table and Narrative</p>	<p align="center">4</p> <p align="center">Operational BMPs—Include in WQMP Table and Narrative</p>
<p><input type="checkbox"/> D1. Need for future indoor & structural pest control</p>		<p><input type="checkbox"/> Note building design features that discourage entry of pests.</p>	<p><input type="checkbox"/> Provide Integrated Pest Management information to owners, lessees, and operators.</p>
<p><input checked="" type="checkbox"/> D2. Landscape/ Outdoor Pesticide Use</p>	<p><input type="checkbox"/> Show locations of native trees or areas of shrubs and ground cover to be undisturbed and retained.</p> <p><input checked="" type="checkbox"/> Show self-retaining landscape areas, if any.</p> <p><input checked="" type="checkbox"/> Show stormwater treatment and hydrograph modification management BMPs. (See instructions in Chapter 3, Step 5 and guidance in Chapter 5.)</p>	<p>State that final landscape plans will accomplish all of the following.</p> <p><input type="checkbox"/> Preserve existing native trees, shrubs, and ground cover to the maximum extent possible.</p> <p><input checked="" type="checkbox"/> Design landscaping to minimize irrigation and runoff, to promote surface infiltration where appropriate, and to minimize the use of fertilizers and pesticides that can contribute to stormwater pollution.</p> <p><input checked="" type="checkbox"/> Where landscaped areas are used to retain or detain stormwater, specify plants that are tolerant of saturated soil conditions.</p> <p><input type="checkbox"/> Consider using pest-resistant plants, especially adjacent to hardscape.</p> <p><input type="checkbox"/> To insure successful establishment, select plants appropriate to site soils, slopes, climate, sun, wind, rain, land use, air movement, ecological consistency, and plant interactions.</p>	<p><input checked="" type="checkbox"/> Maintain landscaping using minimum or no pesticides.</p> <p><input type="checkbox"/> See applicable operational BMPs in “What you should know for....Landscape and Gardening” at http://rcfllood.org/stormwater/Error Hyperlink reference not valid.</p> <p><input checked="" type="checkbox"/> Provide IPM information to new owners, lessees and operators.</p>

STORMWATER POLLUTANT SOURCES / SOURCE CONTROL CHECKLIST

... THEN YOUR WQMP SHOULD INCLUDE THESE SOURCE CONTROL BMPs, AS APPLICABLE			
1	2	3	4
IF THESE SOURCES WILL BE ON THE PROJECT SITE ...	Permanent Controls—Show on WQMP Drawings	Permanent Controls—List in WQMP Table and Narrative	Operational BMPs—Include in WQMP Table and Narrative
<p><input checked="" type="checkbox"/> E. Pools, spas, ponds, decorative fountains, and other water features.</p>	<p><input checked="" type="checkbox"/> Show location of water feature and a sanitary sewer cleanout in an accessible area within 10 feet. (Exception: Public pools must be plumbed according to County Department of Environmental Health Guidelines.)</p>	<p>If the Co-Permittee requires pools to be plumbed to the sanitary sewer, place a note on the plans and state in the narrative that this connection will be made according to local requirements.</p>	<p><input checked="" type="checkbox"/> See applicable operational BMPs in "Guidelines for Maintaining Your Swimming Pool, Jacuzzi and Garden Fountain" at http://rcflood.org/stormwater/</p>
<p><input type="checkbox"/> F. Food service</p>	<p><input type="checkbox"/> For restaurants, grocery stores, and other food service operations, show location (indoors or in a covered area outdoors) of a floor sink or other area for cleaning floor mats, containers, and equipment.</p> <p><input type="checkbox"/> On the drawing, show a note that this drain will be connected to a grease interceptor before discharging to the sanitary sewer.</p>	<p><input type="checkbox"/> Describe the location and features of the designated cleaning area.</p> <p><input type="checkbox"/> Describe the items to be cleaned in this facility and how it has been sized to insure that the largest items can be accommodated.</p>	<p><input type="checkbox"/> See the brochure, "The Food Service Industry Best Management Practices for: Restaurants, Grocery Stores, Delicatessens and Bakeries" at http://rcflood.org/stormwater/</p> <p>Provide this brochure to new site owners, lessees, and operators.</p>
<p><input checked="" type="checkbox"/> G. Refuse areas</p>	<p><input checked="" type="checkbox"/> Show where site refuse and recycled materials will be handled and stored for pickup. See local municipal requirements for sizes and other details of refuse areas.</p> <p><input type="checkbox"/> If dumpsters or other receptacles are outdoors, show how the designated area will be covered, graded, and paved to prevent runoff and show locations of berms to prevent runoff from the area.</p> <p><input type="checkbox"/> Any drains from dumpsters, compactors, and tallow bin areas shall be connected to a grease removal device before discharge to sanitary sewer.</p>	<p><input checked="" type="checkbox"/> State how site refuse will be handled and provide supporting detail to what is shown on plans.</p> <p><input type="checkbox"/> State that signs will be posted on or near dumpsters with the words "Do not dump hazardous materials here" or similar.</p>	<p><input checked="" type="checkbox"/> State how the following will be implemented:</p> <p>Provide adequate number of receptacles. Inspect receptacles regularly; repair or replace leaky receptacles. Keep receptacles covered. Prohibit/prevent dumping of liquid or hazardous wastes. Post "no hazardous materials" signs. Inspect and pick up litter daily and clean up spills immediately. Keep spill control materials available on-site. See Fact Sheet SC-34, "Waste Handling and Disposal" in the CASQA Stormwater Quality Handbooks at www.cabmphandbooks.com</p>

STORMWATER POLLUTANT SOURCES / SOURCE CONTROL CHECKLIST

IF THESE SOURCES WILL BE ON THE PROJECT SITE THEN YOUR WQMP SHOULD INCLUDE THESE SOURCE CONTROL BMPs, AS APPLICABLE		
<p align="center">1</p> <p>Potential Sources of Runoff Pollutants</p> <p><input type="checkbox"/> H. Industrial processes.</p>	<p align="center">2</p> <p>Permanent Controls—Show on WQMP Drawings</p> <p><input type="checkbox"/> Show process area.</p>	<p align="center">3</p> <p>Permanent Controls—List in WQMP Table and Narrative</p> <p><input type="checkbox"/> If industrial processes are to be located on site, state: "All process activities to be performed indoors. No processes to drain to exterior or to storm drain system."</p>	<p align="center">4</p> <p>Operational BMPs—Include in WQMP Table and Narrative</p> <p><input type="checkbox"/> See Fact Sheet SC-10, "Non-Stormwater Discharges" in the CASQA Stormwater Quality Handbooks at www.cabmp手books.com See the brochure "Industrial & Commercial Facilities Best Management Practices for Industrial, Commercial Facilities" at http://rcflood.org/stormwater/</p>

STORMWATER POLLUTANT SOURCES / SOURCE CONTROL CHECKLIST

<p align="center">1</p> <p align="center">IF THESE SOURCES WILL BE ON THE PROJECT SITE ...</p>	<p align="center">2</p> <p align="center">Permanent Controls—Show on WQMP Drawings</p>	<p align="center">3</p> <p align="center">Permanent Controls—List in WQMP Table and Narrative</p>	<p align="center">4</p> <p align="center">Operational BMPs—Include in WQMP Table and Narrative</p>
<p><input type="checkbox"/> I. Outdoor storage of equipment or materials. (See rows J and K for source control measures for vehicle cleaning, repair, and maintenance.)</p>	<p><input type="checkbox"/> Show any outdoor storage areas, including how materials will be covered. Show how areas will be graded and bermed to prevent run-on or run-off from area.</p> <p><input type="checkbox"/> Storage of non-hazardous liquids shall be covered by a roof and/or drain to the sanitary sewer system, and be contained by berms, dikes, liners, or vaults.</p> <p><input type="checkbox"/> Storage of hazardous materials and wastes must be in compliance with the local hazardous materials ordinance and a Hazardous Materials Management Plan for the site.</p>	<p>Include a detailed description of materials to be stored, storage areas, and structural features to prevent pollutants from entering storm drains.</p> <p>Where appropriate, reference documentation of compliance with the requirements of Hazardous Materials Programs for:</p> <ul style="list-style-type: none"> ▪ Hazardous Waste Generation ▪ Hazardous Materials Release Response and Inventory ▪ California Accidental Release (CalARP) ▪ Aboveground Storage Tank ▪ Uniform Fire Code Article 80 Section 103(b) & (c) 1991 ▪ Underground Storage Tank <p>www.cdhealth.org/groups/hazmat /</p>	<p><input type="checkbox"/> See the Fact Sheets SC-31, "Outdoor Liquid Container Storage" and SC-33, "Outdoor Storage of Raw Materials" in the CASQA Stormwater Quality Handbooks at www.cabmphandbooks.com</p>

STORMWATER POLLUTANT SOURCES / SOURCE CONTROL CHECKLIST

<p align="center">1</p> <p align="center">IF THESE SOURCES WILL BE ON THE PROJECT SITE ...</p>	<p align="center">... THEN YOUR WQMP SHOULD INCLUDE THESE SOURCE CONTROL BMPs, AS APPLICABLE</p>		
<p align="center">2</p> <p align="center">Permanent Controls—Show on WQMP Drawings</p>	<p align="center">3</p> <p align="center">Permanent Controls—List in WQMP Table and Narrative</p>	<p align="center">4</p> <p align="center">Operational BMPs—Include in WQMP Table and Narrative</p>	
<p><input type="checkbox"/> J. Vehicle and Equipment Cleaning</p>	<p><input type="checkbox"/> Show on drawings as appropriate:</p> <p>(1) Commercial/industrial facilities having vehicle/equipment cleaning needs shall either provide a covered, bermed area for washing activities or discourage vehicle/equipment washing by removing hose bibs and installing signs prohibiting such uses.</p> <p>(2) Multi-dwelling complexes shall have a paved, bermed, and covered car wash area (unless car washing is prohibited on-site and hoses are provided with an automatic shut-off to discourage such use).</p> <p>(3) Washing areas for cars, vehicles, and equipment shall be paved, designed to prevent run-on to or runoff from the area, and plumbed to drain to the sanitary sewer.</p> <p>(4) Commercial car wash facilities shall be designed such that no runoff from the facility is discharged to the storm drain system. Wastewater from the facility shall discharge to the sanitary sewer, or a wastewater reclamation system shall be installed.</p>	<p><input type="checkbox"/> If a car wash area is not provided, describe any measures taken to discourage on-site car washing and explain how these will be enforced.</p>	<p>Describe operational measures to implement the following (if applicable):</p> <p><input type="checkbox"/> Wastewater from vehicle and equipment washing operations shall not be discharged to the storm drain system. Refer to "Outdoor Cleaning Activities and Professional Mobile Service Providers" for many of the Potential Sources of Runoff Pollutants categories below. Brochure can be found at http://rcflood.org/stormwater/</p> <p><input type="checkbox"/> Car dealerships and similar may rinse cars with water only.</p>

STORMWATER POLLUTANT SOURCES / SOURCE CONTROL CHECKLIST

<p>1 IF THESE SOURCES WILL BE ON THE PROJECT SITE ...</p>	<p>2 Permanent Controls—Show on WQMP Drawings</p>	<p>3 Permanent Controls—List in WQMP Table and Narrative</p>	<p>4 Operational BMPs—Include in WQMP Table and Narrative</p>
<p><input type="checkbox"/> K. Vehicle/Equipment Repair and Maintenance</p>	<p><input type="checkbox"/> Accommodate all vehicle equipment repair and maintenance indoors. Or designate an outdoor work area and design the area to prevent run-on and runoff of stormwater.</p> <p><input type="checkbox"/> Show secondary containment for exterior work areas where motor oil, brake fluid, gasoline, diesel fuel, radiator fluid, acid-containing batteries or other hazardous materials or hazardous wastes are used or stored. Drains shall not be installed within the secondary containment areas.</p> <p><input type="checkbox"/> Add a note on the plans that states either (1) there are no floor drains, or (2) floor drains are connected to wastewater pretreatment systems prior to discharge to the sanitary sewer and an industrial waste discharge permit will be obtained.</p>	<p><input type="checkbox"/> State that no vehicle repair or maintenance will be done outdoors, or else describe the required features of the outdoor work area.</p> <p><input type="checkbox"/> State that there are no floor drains or if there are floor drains, note the agency from which an industrial waste discharge permit will be obtained and that the design meets that agency's requirements.</p> <p><input type="checkbox"/> State that there are no tanks, containers or sinks to be used for parts cleaning or rinsing or, if there are, note the agency from which an industrial waste discharge permit will be obtained and that the design meets that agency's requirements.</p>	<p>In the Stormwater Control Plan, note that all of the following restrictions apply to use the site:</p> <p><input type="checkbox"/> No person shall dispose of, nor permit the disposal, directly or indirectly of vehicle fluids, hazardous materials, or rinsewater from parts cleaning into storm drains.</p> <p><input type="checkbox"/> No vehicle fluid removal shall be performed outside a building, nor on asphalt or ground surfaces, whether inside or outside a building, except in such a manner as to ensure that any spilled fluid will be in an area of secondary containment. Leaking vehicle fluids shall be contained or drained from the vehicle immediately.</p> <p><input type="checkbox"/> No person shall leave unattended drip parts or other open containers containing vehicle fluid, unless such containers are in use or in an area of secondary containment.</p> <p>Refer to "Automotive Maintenance & Car Care Best Management Practices for Auto Body Shops, Auto Repair Shops, Car Dealerships, Gas Stations and Fleet Service Operations". Brochure can be found at http://rcflood.org/stormwater/</p> <p>Refer to Outdoor Cleaning Activities and Professional Mobile Service Providers for many of the Potential Sources of Runoff Pollutants categories below. Brochure can be found at http://rcflood.org/stormwater/</p>

STORMWATER POLLUTANT SOURCES / SOURCE CONTROL CHECKLIST

<p>IF THESE SOURCES WILL BE ON THE PROJECT SITE ...</p>	<p align="center">... THEN YOUR WQMP SHOULD INCLUDE THESE SOURCE CONTROL BMPs, AS APPLICABLE</p>		
<p>1 Potential Sources of Runoff Pollutants</p>	<p align="center">2 Permanent Controls—Show on WQMP Drawings</p>	<p align="center">3 Permanent Controls—List in WQMP Table and Narrative</p>	<p align="center">4 Operational BMPs—Include in WQMP Table and Narrative</p>
<p><input type="checkbox"/> L. Fuel Dispensing Areas</p>	<p><input type="checkbox"/> Fueling areas⁶ shall have impermeable floors (i.e., portland cement concrete or equivalent smooth impervious surface) that are: a) graded at the minimum slope necessary to prevent ponding; and b) separated from the rest of the site by a grade break that prevents run-on of stormwater to the maximum extent practicable.</p> <p><input type="checkbox"/> Fueling areas shall be covered by a canopy that extends a minimum of ten feet in each direction from each pump. [Alternative: The fueling area must be covered and the cover's minimum dimensions must be equal to or greater than the area within the grade break or fuel dispensing area¹.] The canopy [or cover] shall not drain onto the fueling area.</p>		<p><input type="checkbox"/> The property owner shall dry sweep the fueling area routinely.</p> <p><input type="checkbox"/> See the Fact Sheet SD-30, "Fueling Areas" in the CASQA Stormwater Quality Handbooks at www.cabmphandbooks.com</p>

⁶ The fueling area shall be defined as the area extending a minimum of 6.5 feet from the corner of each fuel dispenser or the length at which the hose and nozzle assembly may be operated plus a minimum of one foot, whichever is greater.

STORMWATER POLLUTANT SOURCES / SOURCE CONTROL CHECKLIST

<p align="center">IF THESE SOURCES WILL BE ON THE PROJECT SITE ...</p>	<p align="center">... THEN YOUR WQMP SHOULD INCLUDE THESE SOURCE CONTROL BMPs, AS APPLICABLE</p>		
<p align="center">1</p> <p>Potential Sources of Runoff Pollutants</p>	<p align="center">2</p> <p>Permanent Controls—Show on WQMP Drawings</p>	<p align="center">3</p> <p>Permanent Controls—List in WQMP Table and Narrative</p>	<p align="center">4</p> <p>Operational BMPs—Include in WQMP Table and Narrative</p>
<p><input type="checkbox"/> M. Loading Docks</p>	<p><input type="checkbox"/> Show a preliminary design for the loading dock area, including roofing and drainage. Loading docks shall be covered and/or graded to minimize run-on to and runoff from the loading area. Roof downspouts shall be positioned to direct stormwater away from the loading area. Water from loading dock areas shall be drained to the sanitary sewer, or diverted and collected for ultimate discharge to the sanitary sewer.</p> <p><input type="checkbox"/> Loading dock areas draining directly to the sanitary sewer shall be equipped with a spill control valve or equivalent device, which shall be kept closed during periods of operation.</p> <p><input type="checkbox"/> Provide a roof overhang over the loading area or install door skirts (cowling) at each bay that enclose the end of the trailer.</p>		<p><input type="checkbox"/> Move loaded and unloaded items indoors as soon as possible.</p> <p><input type="checkbox"/> See Fact Sheet SC-30, "Outdoor Loading and Unloading," in the CASQA Stormwater Quality Handbooks at www.cabmphandbooks.com</p>

STORMWATER POLLUTANT SOURCES / SOURCE CONTROL CHECKLIST

<p align="center">1</p> <p align="center">IF THESE SOURCES WILL BE ON THE PROJECT SITE ...</p>	<p align="center">2</p> <p align="center">Permanent Controls—Show on WQMP Drawings</p>	<p align="center">3</p> <p align="center">Permanent Controls—List in WQMP Table and Narrative</p>	<p align="center">4</p> <p align="center">Operational BMPs—Include in WQMP Table and Narrative</p>
<p><input type="checkbox"/> N. Fire Sprinkler Test Water</p>	<p><input type="checkbox"/> Provide a means to drain fire sprinkler test water to the sanitary sewer.</p>	<p><input type="checkbox"/> See the note in Fact Sheet SC-41, “Building and Grounds Maintenance,” in the CASQA Stormwater Quality Handbooks at www.cabmphandbooks.com</p>	
<p><input type="checkbox"/> O. Miscellaneous Drain or Wash Water or Other Sources</p> <p><input type="checkbox"/> Boiler drain lines</p> <p><input type="checkbox"/> Condensate drain lines</p> <p><input type="checkbox"/> Rooftop equipment</p> <p><input type="checkbox"/> Drainage sumps</p> <p><input type="checkbox"/> Roofings, gutters, and trim.</p> <p><input type="checkbox"/> Other sources</p>	<p><input type="checkbox"/> Boiler drain lines shall be directly or indirectly connected to the sanitary sewer system and may not discharge to the storm drain system.</p> <p><input type="checkbox"/> Condensate drain lines may discharge to landscaped areas if the flow is small enough that runoff will not occur. Condensate drain lines may not discharge to the storm drain system.</p> <p><input type="checkbox"/> Rooftop equipment with potential to produce pollutants shall be roofed and/or have secondary containment.</p> <p><input type="checkbox"/> Any drainage sumps on-site shall feature a sediment sump to reduce the quantity of sediment in pumped water.</p> <p><input type="checkbox"/> Avoid roofing, gutters, and trim made of copper or other unprotected metals that may leach into runoff.</p> <p><input type="checkbox"/> Include controls for other sources as specified by local reviewer.</p>		

STORMWATER POLLUTANT SOURCES / SOURCE CONTROL CHECKLIST

IF THESE SOURCES WILL BE ON THE PROJECT SITE THEN YOUR WQMP SHOULD INCLUDE THESE SOURCE CONTROL BMPs, AS APPLICABLE		
1 Potential Sources of Runoff Pollutants	2 Permanent Controls—Show on WQMP Drawings	3 Permanent Controls—List in WQMP Table and Narrative	4 Operational BMPs—Include in WQMP Table and Narrative
<input checked="" type="checkbox"/> P. Plazas, sidewalks, and parking lots.			<input checked="" type="checkbox"/> Sweep plazas, sidewalks, and parking lots regularly to prevent accumulation of litter and debris. Collect debris from pressure washing to prevent entry into the storm drain system. Collect washwater containing any cleaning agent or degreaser and discharge to the sanitary sewer not to a storm drain.

Appendix 9: O&M

Operation and Maintenance Plan and Documentation of Finance, Maintenance and Recording Mechanisms

BMP Name	BMP Location	Frequency
Structural Treatment		
Catch Basin Marker Inspection	As designated on WQMP Plot Plan	Bi-annually
Catch Basin Marker Maintenance	As designated on WQMP Plot Plan	Yearly
Trash Storage Areas	As designated on WQMP Plot Plan	Weekly basis
Irrigation and Landscape	As designated on WQMP Plot Plan	Monthly basis
Non-Structural Treatment		
Educational Material	Manager's Office	Upon hire and annually
Activity Restriction	Manager's Office	Daily basis
Common Landscape Management	Throughout project site	Monthly basis
BMP Maintenance	Manager's Office & staff	Daily basis
Common Area Litter Control	Throughout project site	Weekly basis
Employee Training	Manager's Office	Upon hire and annually
Common Area Catch Basin Inspection	As designated on WQMP Plot Plan	After and before rain storm
Sweeping of Parking Structure/Driveway	As designated on WQMP Plot Plan	Monthly basis
Fountain and Pool Maintenance	As designated on WQMP Plot Plan	As needed
Treatment Control		
Aqua-Swirl Inspection	As designated on WQMP Plot Plan	Quarterly, before, during, after rain event
Aqua-Swirl Maintenance	As designated on WQMP Plot Plan	Annually and as needed
CMP Inspection	As designated on WQMP Plot Plan	Quarterly, before, during, after rain event
CMP Maintenance	As designated on WQMP Plot Plan	Annually and as needed
Drywell Inspection	As designated on WQMP Plot Plan	Quarterly, before, during, after rain event
Drywell Maintenance	As designated on WQMP Plot Plan	Annually and as needed

MaxWell IV Drywell

The Operation and Maintenance Program will include the following key components:

1. Inspection Procedures:

The settling chambers and internal components of the unit will be inspected regularly. Additionally, an assessment of the site drainage will be conducted to insure that the system meets operation guidelines. The visual inspection will ascertain that the unit is functioning properly (no blockages or obstructions to inlet and/or infiltration chamber), measuring the amount of solid materials, fine sediment, and floating trash and debris within the chamber. Schedules for inspections and cleanout will be based on storm events and pollutant accumulation due to failure of upstream pre-treatment device. During the rainfall season, the unit will be inspected at least once every 30 days. Accumulation of sediment and floatable material captured by the MaxWell IV will be recorded in a maintenance log.

2. Cleanout Procedures:

Truck mounted hydro-vactor equipment will be used to clean the system utilizing water and air to dislodge and remove debris and sediment deposits. All chambers, inlets, connecting piping and catch basins are cleaned and the contents discharged. The accumulated contents are transported off-site for disposal. Within each chamber, geotextile fabric base seals and hydrophobic petrochemical sponges are removed and replaced. Inlet grates and covers are re-installed and then re-secured with the existing locking devices.

3. Stenciling:

Legibility of stencils and/or signs at all storm drain inlets and catch basins within the project area must be maintained at all time.

4. Maintenance Log:

Keep on-site a log of all inspections and maintenance performed on the MaxWell IV.



Maintenance

Underground storm water detention and retention systems should be inspected at regular intervals and maintained when necessary to ensure optimum performance. The rate at which the system collects pollutants will depend more heavily on site activities than the size or configuration of the system.

Inspection

Inspection is the key to effective maintenance and is easily performed. CONTECH recommends ongoing quarterly inspections of the accumulated sediment. Sediment deposition and transport may vary from year to year and quarterly inspections will help insure that systems are cleaned out at the appropriate time. Inspections should be performed more often in the winter months in climates where sanding operations may lead to rapid accumulations, or in equipment washdown areas. It is very useful to keep a record of each inspection. A sample inspection log is included for your use.

Systems should be cleaned when inspection reveals that accumulated sediment or trash is clogging the discharge orifice. CONTECH suggests that all systems be designed with an access/inspection manhole situated at or near the inlet and the outlet orifice. Should it be necessary to get inside the system to perform maintenance activities, all appropriate precautions regarding confined space entry and OSHA regulations should be followed.

Cleaning

Maintaining an underground detention or retention system is easiest when there is no flow entering the system. For this reason, it is a good idea to schedule the cleanout during dry weather.

Accumulated sediment and trash can typically be evacuated through the manhole over the outlet orifice. If maintenance is not performed as recommended, sediment and trash may accumulate in front of the outlet orifice. Manhole covers should be securely seated following cleaning activities.



Aqua-Swirl[®]

Stormwater Treatment System

Inspection and Maintenance Manual



AquaShield[™], Inc.
2733 Kanasita Drive
Suite 111
Chattanooga, TN 37343
Toll free (888) 344-9044
Phone: (423) 870-8888
Fax: (423) 826-2112
Email: info@aquashieldinc.com
www.aquashieldinc.com

March 2014

Table of Contents

	<u>Page(s)</u>
• AquaShield™ Stormwater Treatment Systems	3
• Aqua-Swirl® Stormwater Treatment System	4 – 9
• Inspection and Maintenance Worksheets and Attachments	10 – 13
• Aqua-Swirl® Tabular Maintenance Schedule	14

AquaShield™, Inc.
2733 Kanasita Drive
Suite 111
Chattanooga, Tennessee 37343
Toll free (888) 344-9044
Fax (423) 870-2112
www.aquashieldinc.com



AquaShield™, Inc **Stormwater Treatment Solutions**

The highest priority of AquaShield™, Inc. (AquaShield™) is to protect waterways by providing stormwater treatment solutions to businesses across the world. These solutions have a reliable foundation based on over 20 years of water treatment experience.

Local regulators, engineers, and contractors have praised the AquaShield™ systems for their simple design and ease of installation. All the systems are fabricated from high performance, durable and lightweight materials. Contractors prefer the quick and simple installation of our structures that saves them money.

The patented line of AquaShield™ stormwater treatment products that provide high levels of stormwater treatment include the following:

- **Aqua-Swirl® Stormwater Treatment System:** hydrodynamic separator, which provides a highly effective means for the removal of sediment, floating debris and free-oil.
- **Aqua-Filter™ Stormwater Filtration System:** treatment train stormwater filtration system capable of removing gross contaminants, fine sediments, waterborne hydrocarbons, heavy metals and total phosphorous.



**Aqua-Swirl® Stormwater
Treatment System**



**Aqua-Filter™ Stormwater
Filtration System**



Aqua-Swirl[®] Stormwater Treatment System

The patented Aqua-Swirl[®] Stormwater Treatment System is a single chamber hydrodynamic separator which provides a highly effective means for the removal of sediment, free oil, and floating debris. Both treatment and storage are accomplished in the swirl chamber without the use of multiple or “blind” chambers. Independent laboratory and field performance verifications have shown that the Aqua-Swirl[®] achieves over 80% suspended solids removal efficiency on a net annual basis.

The Aqua-Swirl[®] is most commonly installed in an “off-line” configuration. Or, depending on local regulations, an “in-line” (on-line) conveyance flow diversion (CFD) system can be used. The CFD model allows simple installation by connecting directly to the existing storm conveyance pipe thereby providing full treatment of the “first flush,” while the peak design storm is diverted and channeled through the main conveyance pipe.

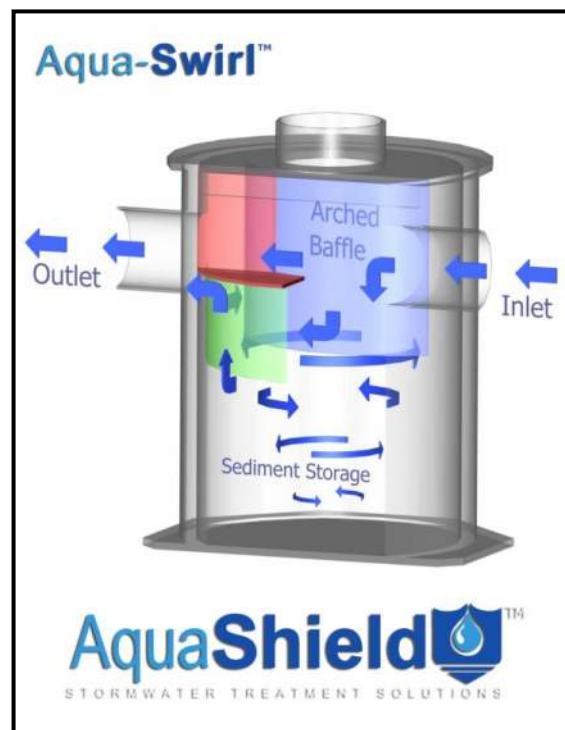

The patented Aqua-Swirl[®] Stormwater Treatment System provides a highly effective means for the removal of sediment, floating debris, and free oil. Swirl technology, or vortex separation, is a proven form of treatment utilized in the stormwater industry to accelerate gravitational separation.



Floatable debris in the Aqua-Swirl®

Each Aqua-Swirl® is constructed of high performance, lightweight and durable materials including polymer coated steel (PCS), high density polyethylene (HDPE), or fiberglass reinforced polymer (FRP). These materials eliminate the need for heavy lifting equipment during installation.



System Operation

The treatment operation begins when stormwater enters the Aqua-Swirl® through a tangential inlet pipe that produces a circular (or vortex) flow pattern that causes contaminants to settle to the base of the unit. Since stormwater flow is intermittent by nature, the Aqua-Swirl® retains water between storm events providing both dynamic and quiescent settling of solids. The dynamic settling occurs during each storm event while the quiescent settling takes place between successive storms. A combination of gravitational and hydrodynamic drag forces encourages the solids to drop out of the flow and migrate to the center of the chamber where velocities are the lowest.

The treated flow then exits the Aqua-Swirl® behind the arched outer baffle. The top of the baffle is sealed across the treatment channel, thereby eliminating floatable pollutants from escaping the system. A vent pipe is extended up the riser to expose the backside of the baffle to atmospheric conditions, preventing a siphon from forming at the bottom of the baffle.



Custom Applications

The Aqua-Swirl® system can be modified to fit a variety of purposes in the field, and the angles for inlet and outlet lines can be modified to fit most applications. The photo below demonstrates the flexibility of Aqua-Swirl® installations using a “twin” configuration in order to double the

water quality treatment capacity. Two Aqua-Swirl[®] units were placed side by side in order to treat a high volume of water while occupying a small amount of space.



Custom designed AS-9 Twin Aqua-Swirl[®]



Retrofit Applications

The Aqua-Swirl[®] system is designed so that it can easily be used for retrofit applications. With the invert of the inlet and outlet pipe at the same elevation, the Aqua-Swirl[®] can easily be connected directly to the existing storm conveyance drainage system. Furthermore, because of the lightweight nature and small footprint of the Aqua-Swirl[®], existing infrastructure utilities (i.e., wires, poles, trees) would be unaffected by installation.



AquaShield[™] Product System Maintenance

The long term performance of any stormwater treatment structure, including manufactured or land based systems, depends on a consistent maintenance plan. Inspection and maintenance functions are simple and easy for the AquaShield[™] Stormwater Treatment Systems allowing all inspections to be performed from the surface.

It is important that a routine inspection and maintenance program be established for each unit based on: (a) the volume or load of the contaminants of concern, (b) the frequency of releases of contaminants at the facility or location, and (c) the nature of the area being drained.

In order to ensure that our systems are being maintained properly, AquaShield[™] offers a maintenance solution to all of our customers. We will arrange to have maintenance performed.



Inspection

All AquaShield™ products can be inspected from the surface, eliminating the need to enter the systems to determine when cleanout should be performed. In most cases, AquaShield™ recommends a quarterly inspection for the first year of operation to develop an appropriate schedule of maintenance. Based on experience of the system's first year in operation, we recommend that the inspection schedule be revised to reflect the site-specific conditions encountered. Typically, the inspection schedule for subsequent years is reduced to semi-annual inspection.



Aqua-Swirl® Maintenance

The Aqua-Swirl® has been designed to minimize and simplify the inspection and maintenance process. The single chamber system can be inspected and maintained entirely from the surface thereby eliminating the need for confined space entry. Furthermore, the entire structure (specifically, the floor) is accessible for visual inspection from the surface. There are no areas of the structure that are blocked from visual inspection or periodic cleaning. Inspection of any free-floating oil and floatable debris can be directly observed and maintained through the manhole access provided directly over the swirl chamber.

Aqua-Swirl® Inspection Procedure

To inspect the Aqua-Swirl®, a hook is needed to remove the manhole cover. AquaShield™ provides a customized manhole cover with our distinctive logo to make it easy for maintenance crews to locate the system in the field. We also provide a permanent metal information plate

affixed inside the access riser which provides our contact information, the Aqua-Swirl[®] model size, and serial number.

The only tools needed to inspect the Aqua-Swirl[®] system are a flashlight and a measuring device such as a stadia rod or pole. Given the easy and direct accessibility provided, floating oil and debris can be observed directly from the surface. Sediment depths can easily be determined by lowering a measuring device to the top of the sediment pile and to the surface of the water.



Sediment inspection using a stadia rod in a single chamber

The maintenance trigger for Aqua-Swirl[®] Models AS-3 through AS-13 occurs when the sediment pile is within 42 to 48 inches of the standing water surface. For the Aqua-Swirl[®] Model AS-2, maintenance is needed when the top of the sediment pile is measured to be 30 to 32 inches below the standing water surface.

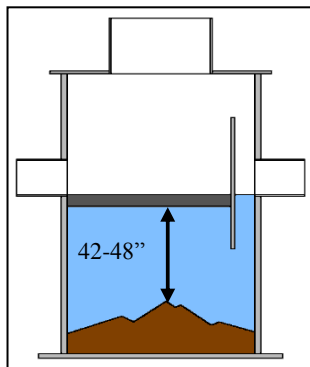

Maintenance trigger for Aqua-Swirl[®] Models AS-3 through AS-13 occurs when sediment pile is 42-48 inches below water surface.

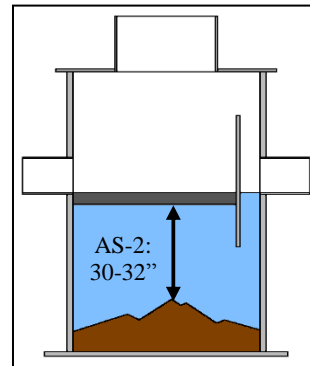

Maintenance trigger for Aqua-Swirl[®] Model AS-2 occurs when sediment pile is 30 to 32 inches below water surface.

It should be noted that in order to avoid underestimating the volume of sediment in the chamber, the measuring device must be carefully lowered to the *top* of the sediment pile. Keep in mind that the finer sediment at the top of the pile may offer less resistance to the measuring device than the larger particles which typically occur deeper within the sediment pile.

The Aqua-Swirl[®] design allows for the sediment to accumulate in a semi-conical fashion as illustrated above. That is, the depth to sediment as measured below the water surface may be less in the center of the swirl chamber; and likewise, may be greater at the edges of the swirl chamber.

Aqua-Swirl[®] Cleanout Procedure

Cleaning the Aqua-Swirl[®] is simple and quick. Free-floating oil and floatable debris can be observed and removed directly through the 30-inch service access riser provided. A vacuum truck is typically used to remove the accumulated sediment and debris. An advantage of the Aqua-Swirl[®] design is that the entire sediment storage area can be reached with a vacuum hose from the surface (reaching all the sides). Since there are no multiple or limited (hidden or “blind”) chambers in the Aqua-Swirl[®], there are no restrictions to impede on-site maintenance tasks.

Disposal of Recovered Materials

Disposal of recovered material is typically handled in the same fashion as catch basin cleanouts. AquaShield[™] recommends that all maintenance activities be performed in accordance with appropriate health and safety practices for the tasks and equipment being used.

AquaShield[™] also recommends that all materials removed from the Aqua-Swirl[®] and any external structures (e.g, bypass features) be handled and disposed in full accordance with any applicable local and state requirements.



Vacuum truck quickly cleans the Aqua-Swirl[®] from a single chamber

***Aqua-Swirl[®] Inspection and Maintenance Work Sheets
on following pages***

Aqua-Swirl[®] Inspection and Maintenance Manual

Work Sheets

SITE and OWNER INFORMATION

Site Name: _____

Site Location: _____

Date: _____ Time: _____

Inspector Name: _____

Inspector Company: _____ Phone #: _____

Owner Name: _____

Owner Address: _____

Owner Phone #: _____ Emergency Phone #: _____

INSPECTIONS

I. Floatable Debris and Oil

1. Remove manhole lid to expose liquid surface of the Aqua-Swirl[®].
2. Remove floatable debris with basket or net if any present.
3. If oil is present, measure its depth. Clean liquids from system if one half (1/2) inch or more oil is present.

Note: Water in Aqua-Swirl[®] can appear black and similar to oil due to the dark body of the surrounding structure. Oil may appear darker than water in the system and is usually accompanied by oil stained debris (e.g. Styrofoam, etc.). The depth of oil can be measured with an oil/water interface probe, a stadia rod with water finding paste, a coliwasa, or collect a representative sample with a jar attached to a rod.

II. Sediment Accumulation

1. Lower measuring device (e.g. stadia rod) into swirl chamber through service access provided until top of sediment pile is reached.
2. Record distance to top of sediment pile from top of standing water: _____ inches
3. For Aqua-Swirl[®] Models AS-3 through AS-13, schedule cleaning if value in Step #2 is 48 to 42 inches or less.
4. For Aqua-Swirl[®] Model AS-2, schedule cleaning if value in Step #2 is 32 to 30 inches or less.

III. Diversion Structures (External Bypass Features)

If a diversion (external bypass) configuration is present, it should be inspected as follows:

1. Inspect weir or other bypass feature for structural decay or damage. Weirs are more susceptible to damage than off-set piping and should be checked to confirm that they are not crumbling (concrete or brick) or decaying (steel).
2. Inspect diversion structure and bypass piping for signs of structural damage or blockage from debris or sediment accumulation.
3. When feasible, measure elevations on diversion weir or piping to ensure it is consistent with site plan designs.
4. Inspect downstream (convergence) structure(s) for sign of blockage or structural failure as noted above.

CLEANING

Schedule cleaning with local vacor company or AquaShield™ to remove sediment, oil and other floatable pollutants. The captured material generally does not require special treatment or handling for disposal. Site-specific conditions or the presence of known contaminants may necessitate that appropriate actions be taken to clean and dispose of materials captured and retained by the Aqua-Swirl®. All cleaning activities should be performed in accordance with property health and safety procedures.

AquaShield™ always recommends that all materials removed from the Aqua-Swirl® during the maintenance process be handled and disposed in accordance with local and state environmental or other regulatory requirements.

MAINTENANCE SCHEDULE

I. During Construction

Inspect the Aqua-Swirl® every three (3) months and clean the system as needed. The Aqua-Swirl® should be inspected and cleaned at the end of construction regardless of whether it has reached its maintenance trigger.

II. First Year Post-Construction

Inspect the Aqua-Swirl® every three (3) months and clean the system as needed.

Inspect and clean the system once annually regardless of whether it has reached its sediment or floatable pollutant storage capacity.

III. Second and Subsequent Years Post-Construction

If the Aqua-Swirl® did not reach full sediment or floatable pollutant capacity in the First Year Post-Construction period, the system can be inspected and cleaned once annually.

If the Aqua-Swirl® reached full sediment or floatable pollutant capacity in less than 12 months in the First Year Post-Construction period, the system should be inspected once

every six (6) months and cleaned as needed. The Aqua-Swirl[®] should be cleaned annually regardless of whether it reaches its sediment or floatable pollutant capacity.

IV. Bypass Structures

Bypass structures should be inspected whenever the Aqua-Swirl[®] is inspected. Maintenance should be performed on bypass structures as needed.

MAINTENANCE COMPANY INFORMATION

Company Name: _____

Street Address: _____

City: _____ State/Prov.: _____ Zip/Postal Code: _____

Contact: _____ Title: _____

Office Phone: _____ Cell Phone: _____

ACTIVITY LOG

Date of Cleaning: _____ (Next inspection should be 3 months from this data for first year).

Time of Cleaning: Start: _____ End: _____

Date of Next Inspection: _____

Floatable debris present: Yes No

Notes: _____

Oil present: Yes No Oil depth (inches): _____

Measurement method and notes: _____

STRUCTURAL CONDITIONS and OBSERVATIONS

Structural damage: Yes No Where: _____

Aqua-Swirl®

TABULAR MAINTENANCE SCHEDULE

Date Construction Started: _____

Date Construction Ended: _____

During Construction

Activity	Month											
	1	2	3	4	5	6	7	8	9	10	11	12
Inspect and Clean as needed			X			X			X			X
Inspect Bypass and maintain as needed			X			X			X			X
Clean System*												X*

* The Aqua-Swirl® should be cleaned **once a year** regardless of whether it has reached full pollutant storage capacity. In addition, the system should be cleaned at the **end of construction** regardless of whether it has reach full pollutant storage capacity.

First Year Post-Construction

Activity	Month											
	1	2	3	4	5	6	7	8	9	10	11	12
Inspect and Clean as needed			X			X			X			X
Inspect Bypass and maintain as needed			X			X			X			X
Clean System*												X*

* The Aqua-Swirl® should be cleaned **once a year** regardless of whether it has reached full pollutant storage capacity.

Second and Subsequent Years Post-Construction

Activity	Month											
	1	2	3	4	5	6	7	8	9	10	11	12
Inspect and Clean as needed												X*
Inspect Bypass, maintain as needed												X*
Clean System*												X*

* If the Aqua-Swirl® did **not** reach full sediment or floatable pollutant capacity in the First Year Post-Construction period, the system can be inspected and cleaned once annually.

If the Aqua-Swirl® **reached** full sediment or floatable pollutant capacity in less than 12 months in the First Year Post-Construction period, the system should be inspected once every six (6) months or more frequently if past history warrants, and cleaned as needed. The Aqua-Swirl® should be cleaned annually regardless of whether it reaches its full sediment or floatable pollutant capacity.

Appendix 10: Educational Materials

BMP Fact Sheets, Maintenance Guidelines and Other End-User BMP Information

To be included with Final WQMP.