

Rev. #	Date	Description

CADENCE CAPITAL INVESTMENTS LLC
 6400 RIDDLERS GREEN CR., STE. 1820
 GREENWOOD VILLAGE, CO 80111
 69084/3981 VAN BUREN BLVD.
 RIVERSIDE, CA 92503
WALL SECTION (PARCEL 2)



Job #: M-1075
 Date: 12/10/21
 Scale: AS NOTED
 Drawn By: SPD

WS2

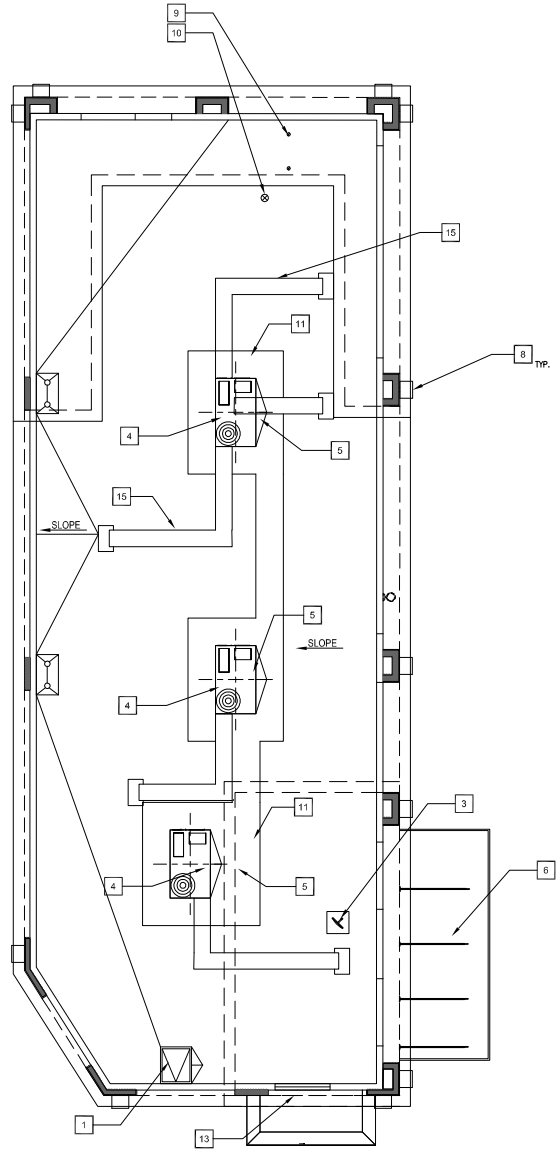

KEYED NOTES

1	ROOF ACCESS	9	EXHAUST DUCT
2	EQUIPMENT PLATFORM	10	PLUMBING VENT
3	SATELLITE DISH	11	WALKING PAD, 30" AROUND ALL MECH. UNITS
4	RTU	12	TRELLIS
5	CRICKET WITH TAPERED INSULATION	13	PICK UP WINDOW
6	PREFINISHED METAL CANOPY	14	6" DOWN LIGHTS
7	EMERGENCY LIGHT	15	AC DUCT
8	EXTERIOR WALL SCONCE - AMERICAN LIGHTING FRAMEWORK STAGE 5" TALL WALL SCONCE		

Rev. #	Date	Description

Job #:	M - 1075
Date:	08/08/22
Scale:	AS NOTED
Drawn By:	SPD

6008-0300 VAN BUREN BLVD. RIVERSIDE, CA 92503	
ROOF PLAN (PARCEL 3)	

ROOF PLAN (PARCEL 3 - RESTAURANT)

1/4"=1'-0" (1)

IFP



WEST TRELLIS ELEVATION (PARCEL 3)

1/4"=1'-0" 2

NORTH TRELLIS ELEVATION (PARCEL 3)

1/4"=1'-0" 1

KEYED NOTES

- 1 TRELLIS
- 2 PROPOSED RESTAURANT

EXTERIOR COLORS & FINISHES

- SHEWEN WILLIAMS PAINT #SW 7034 - STATUS BRONZE
- A



SHEWEN WILLIAMS PAINT #SW 7034 - STATUS BRONZE

Rev. #	Date	Description

6006-6300 VAN DUREN BLVD.
RIVERSIDE, CA 92503

TRELLIS ELEVATION (PARCEL 3)



TRELLIS RENDERING (PARCEL 3)

N.T.S. 3

ELEV

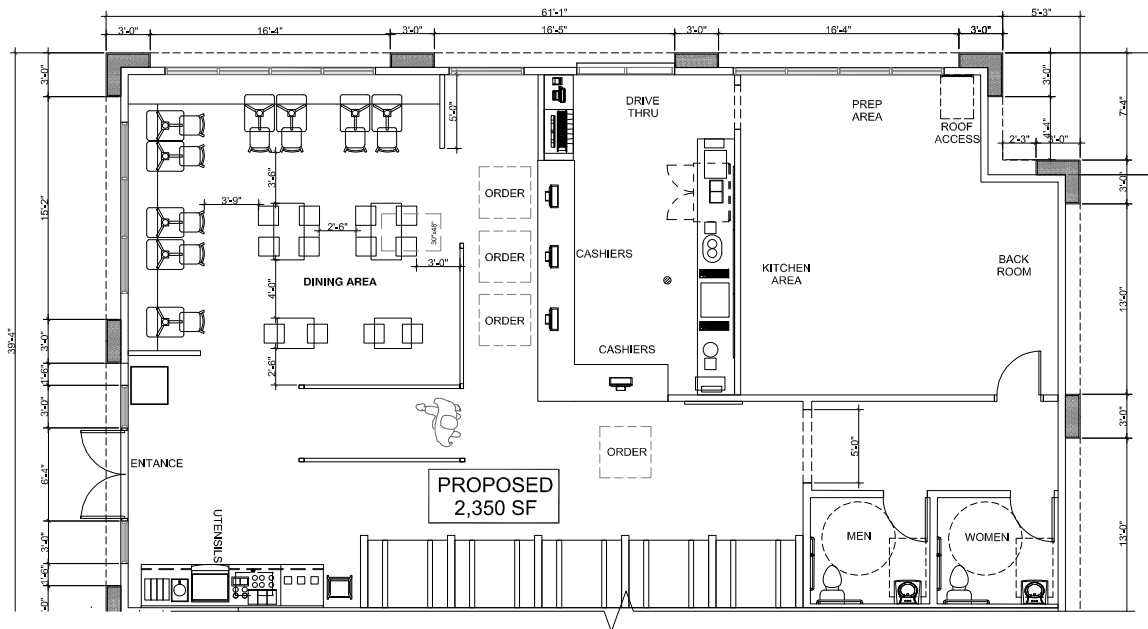

Job #:	M - 1075	Rev. #	
Date:	08/13/22	Date	
Scale:	AS NOTED	Description	
Drawn By:	SPD		
6008-0300 VAN BUREN BLVD. RIVERSIDE, CA 92503			
INTERIOR FLOOR PLAN (DRIVE THRU)			

KEYED NOTES

1	ROOF ACCESS	9	EXHAUST DUCT
2	EQUIPMENT PLATFORM	10	PLUMBING VENT
3	SATELLITE DISH	11	WALKING PAD, 30" AROUND ALL MECH. UNITS
4	RTU	12	TRELLIS
5	CRICKET WITH TAPERED INSULATION	13	PICK UP WINDOW
6	PREFINISHED METAL CANOPY	14	6" DOWN LIGHTS
7	EMERGENCY LIGHT	15	AC DUCT
8	EXTERIOR WALL SCONCE - AMERICAN LIGHTING FRAMEWORK STAGE 5" TALL WALL SCONCE		

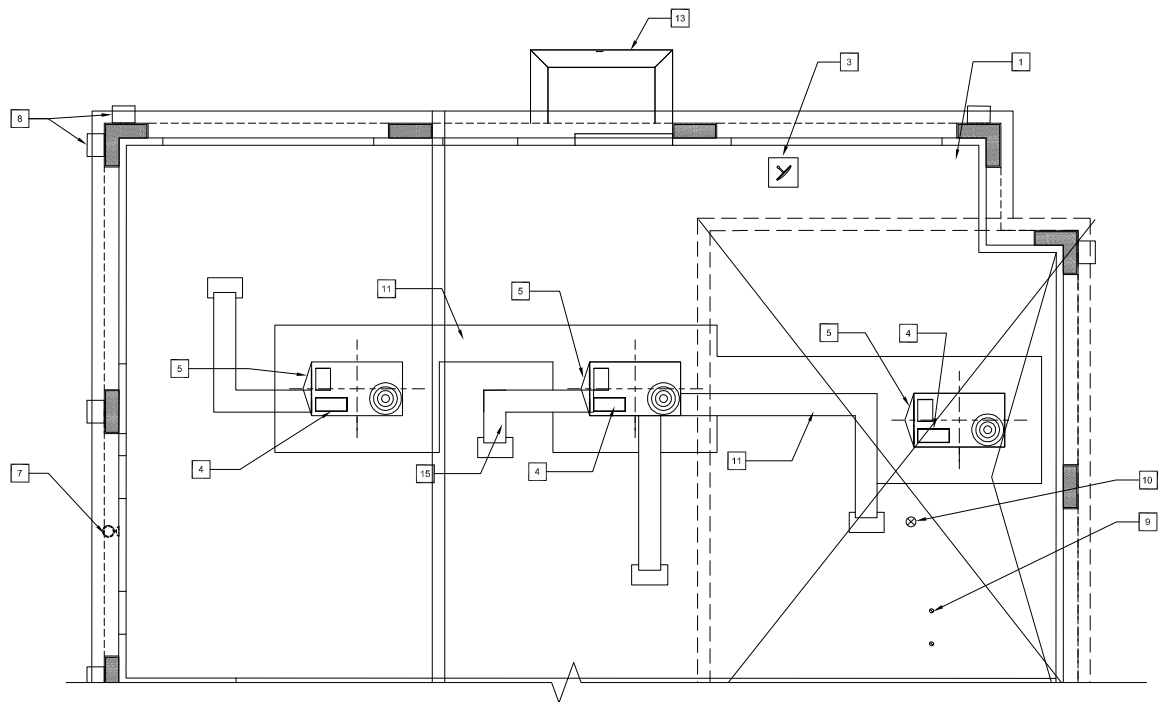

Rev. #	Date	Description

Job #:	M - 1075
Date:	08/13/22
Scale:	AS NOTED
Drawn By:	SPD
6008-0300 VAN BUREN BLVD. RIVERSIDE, CA 92503	
ROOF PLAN (DRIVE THRU)	

KEYED NOTES

1	ROOF ACCESS	9	EXHAUST DUCT
2	EQUIPMENT PLATFORM	10	PLUMBING VENT
3	SATELLITE DISH	11	WALKING PAD, 30" AROUND ALL MECH. UNITS
4	RTU	12	TRELLIS
5	CRICKET WITH TAPERED INSULATION	13	PICK UP WINDOW
6	PREFINISHED METAL CANOPY	14	6" DOWN LIGHTS
7	EMERGENCY LIGHT	15	AC DUCT
8	EXTERIOR WALL SCONCE - AMERICAN LIGHTING FRAMEWORK STAGE 5" TALL WALL SCONCE		

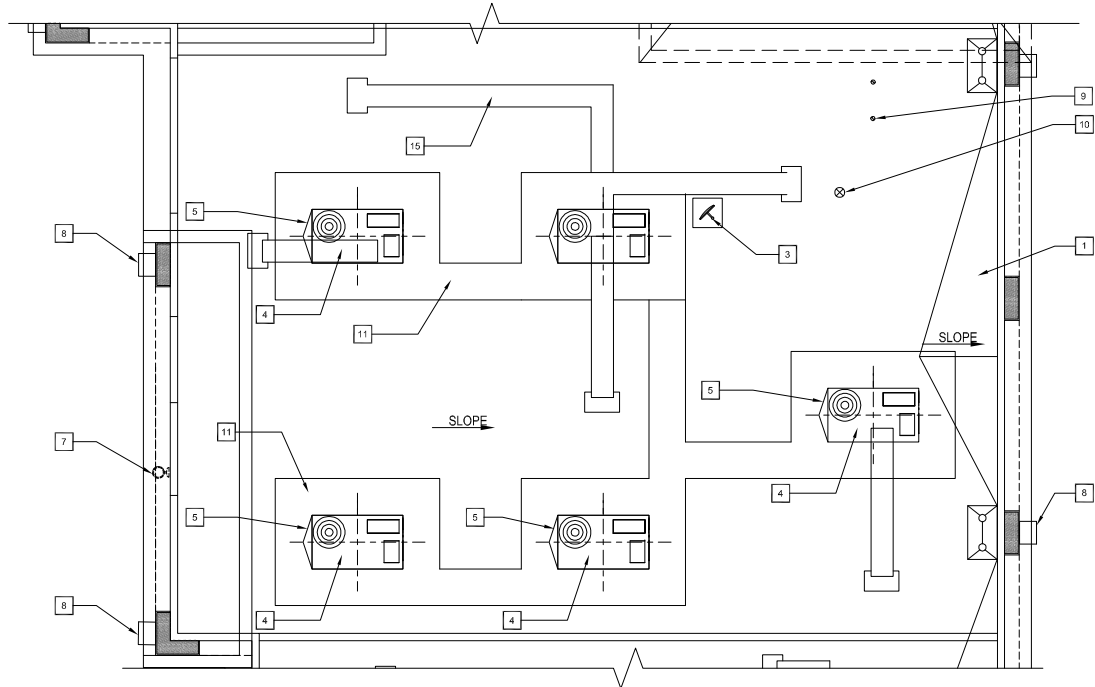

Rev. #	Date	Description

Job #: M - 1075
 Date: 05/10/22
 Scale: AS NOTED
 Drawn By: SPD

6008-0300 VAN BUREN BLVD.
 RIVERSIDE, CA 92503

ROOF PLAN (RESTAURANT)

ROOF PLAN (PARCEL 7 - RESTAURANT)

1/4"=1'-0" (1)

RP2

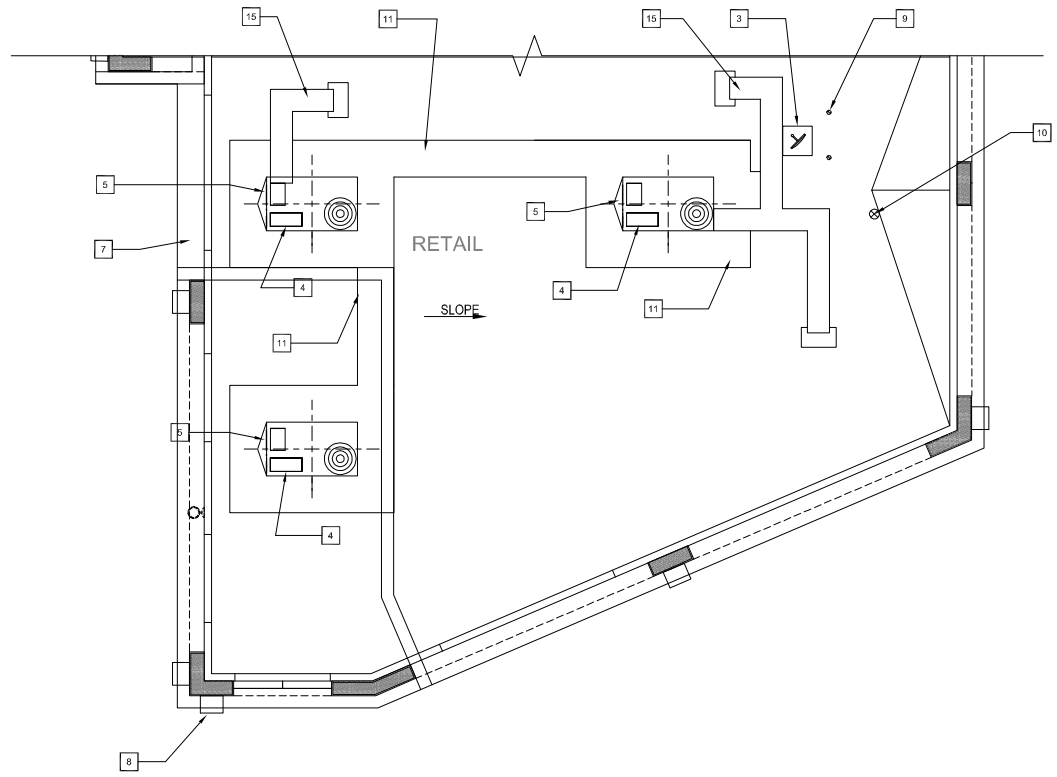

KEYED NOTES

1	ROOF ACCESS	9	EXHAUST DUCT
2	EQUIPMENT PLATFORM	10	PLUMBING VENT
3	SATELLITE DISH	11	WALKING PAD, 30" AROUND ALL MECH. UNITS
4	RTU	12	TRELLIS
5	CRICKET WITH TAPERED INSULATION	13	PICK UP WINDOW
6	PREFINISHED METAL CANOPY	14	6" DOWN LIGHTS
7	EMERGENCY LIGHT	15	AC DUCT
8	EXTERIOR WALL SCONCE - AMERICAN LIGHTING FRAMEWORK STAGE 5" TALL WALL SCONCE		

Rev. #	Date	Description

Job #:	M - 1075
Date:	08/13/22
Scale:	AS NOTED
Drawn By:	SPD
6008-0300 VAN BUREN BLVD. RIVERSIDE, CA 92503	
ROOF PLAN (RETAIL)	